

A. B. WILMOT.
 VALVE FOR TWO CYLINDER ENGINES.
 APPLICATION FILED MAR. 25, 1909.

998,064.

Patented July 18, 1911.

2 SHEETS—SHEET 1.

Fig. 1.

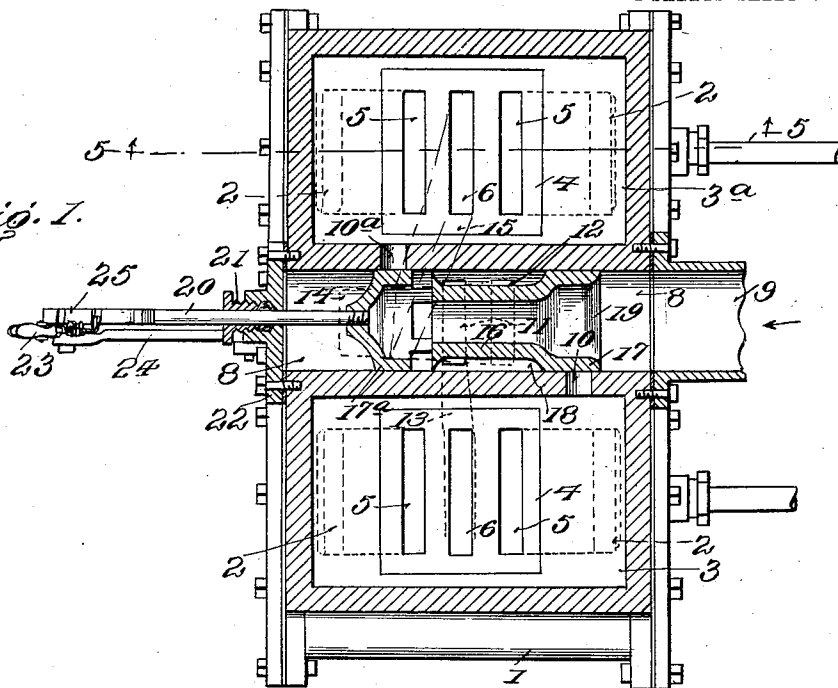
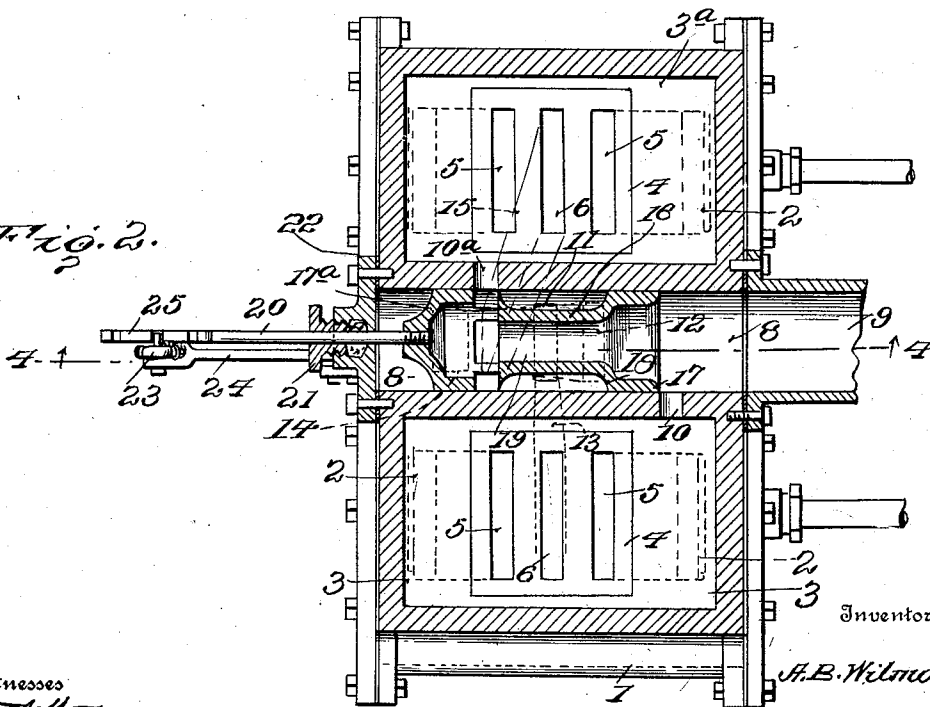

Fig. 2.



Inventor

A. B. Wilmot

Witnesses
 W. A. Woodman
 J. M. Fallin

By

Shankley, Attorneys

A. B. WILMOT.
 VALVE FOR TWO CYLINDER ENGINES.
 APPLICATION FILED MAR. 25, 1909.

998,064.

Patented July 18, 1911.

2 SHEETS—SHEET 2.

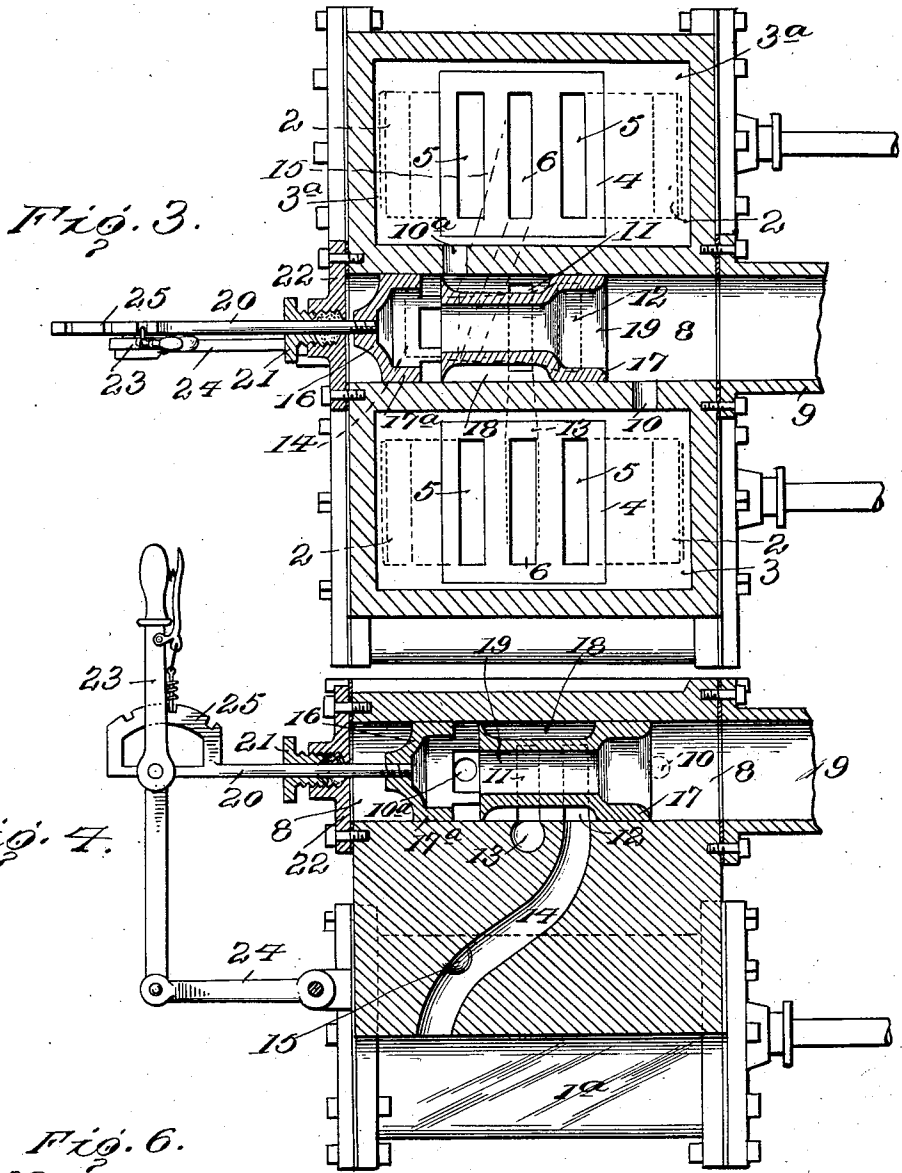

Fig. 4.

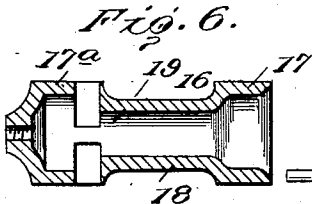

Fig. 6.

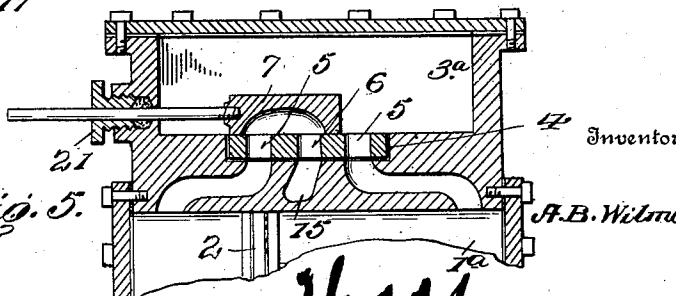

Fig. 5.

Witnesses
W. S. Johnson
J. M. Fallon

Inventor
A. B. Wilmot

Harshbarger, Attorneys.

UNITED STATES PATENT OFFICE.

ARTHUR B. WILMOT, OF EAST CLARIDON, OHIO.

VALVE FOR TWO-CYLINDER ENGINES.

998,064.

Specification of Letters Patent.

Patented July 18, 1911.

Application filed March 25, 1909. Serial No. 485,778.

To all whom it may concern:

Be it known that I, ARTHUR B. WILMOT, citizen of the United States, residing at East Claridon, in the county of Geauga and State of Ohio, have invented certain new and useful Improvements in Valves for Two-Cylinder Engines, of which the following is a specification.

This invention comprehends certain new and useful improvements in steam pressure engines of the two cylinder type, and the invention has for its object an improved valve through the instrumentality of which the engine may be converted from a simple double engine to a compound engine and vice versa, at the will of the operator.

With this and other objects in view that will more fully appear as the description proceeds, the invention consists in certain constructions and arrangements of the parts that I shall hereinafter fully describe and then point out the novel features thereof in the appended claim.

For a full understanding of the invention and the merits thereof and also to acquire a knowledge of the details of construction, reference is to be had to the following description and accompanying drawings, in which:

Figure 1 is a horizontal sectional view of my improved engine showing the intercepting valve in position to close both the inlet ports into the chests; Fig. 2 is a similar view with the valve admitting live steam to both chests to provide a simple double engine; Fig. 3 is a similar view showing the compound engine; Fig. 4 is a vertical section on the line 4—4 of Fig. 2; Fig. 5 is a similar view the section being taken on the line 5—5 of Fig. 1; and Fig. 6 is a detail sectional view of the intercepting valve.

Corresponding and like parts are referred to in the following description and indicated in all the views of the drawings by the same reference characters.

My improved engine consists essentially of two cylinders 1 and 1^a which are adapted to serve as high and low pressure cylinders respectively, and within which are mounted pistons 2. These cylinders are disposed horizontally side by side and may be of any conventional design except that they are provided at their upper walls with steam chests 3 and 3^a. Within these chests are mounted cover plates 4 which are formed with spaced ports 5 having commu-

nication with the opposite ends of the corresponding cylinders, and intermediate of said ports with an exhaust port 6. A slide valve 7 is disposed in each of the steam chests and is designed to be driven in any approved manner so as to be reciprocated across the cover plate to control the admission of steam to the cylinder. Interposed between the two steam chests is a longitudinal valve chamber 8 that has communication at one end with a steam supply pipe 9 and which is formed with longitudinally spaced inlet ports 10 and 10^a through which the steam may be admitted into the respective steam chests. Intermediate of the inlet ports, the wall of the valve chamber is pierced by two longitudinally spaced ports 11 and 12, the port 11 communicating with the intermediate port 6 of the steam chest 3 through a passage 13, while leading from the port 12 is the engine exhaust 14 through which the steam is conducted to a stack or condenser or the like. The port 6 of the steam chest 3^a is connected with the engine exhaust by a passage 15.

In order to control the admission of steam to the various ports, I provide an intercepting valve 16 which is mounted for longitudinal movement in the valve chamber 8 and which in the present instance is provided at its opposite end with outstanding piston heads 17 and 17^a, and is formed intermediate of said heads with a preferably annular peripheral recess 18. The head 17 is adjacent the supply pipe 9 and is formed with a by-pass 19 which leads therefrom and extends longitudinally of the valve and opens outwardly through the periphery of the opposite head 17^a for the purpose to be presently disclosed. The movement of the valve in the chamber is effected by means of a rod or stem 20 that is secured to the head 17^a thereof and passes outwardly through a stuffing box 21 provided on a head 22 which is applied to the corresponding end of the valve chamber. At its outer end the stem is operatively connected to a hand lever 23 which is fulcrumed on an outstanding bracket 24 and is latched to a quadrant 25 whereby to maintain the valve rigidly in adjusted position.

In the practical operation of the engine, when it is desired to run the same as a simple double engine, the intercepting valve 16 is moved to assume the position illustrated in Fig. 2, in which the port 10 is uncovered

and the by-pass 19 registers with the inlet port 10^a, the recess 18 lapping the ports 11 and 12. Steam entering the valve chamber through the supply pipe 9 is therefore admitted to the steam chest 3 through the port 10 and thence passes alternately through the ports 5 into the cylinder 1 to operate the piston therein upon the reciprocation of the corresponding slide valve 7. The steam is exhausted from the chest 3 through the port 6 and the passage 13 and escapes into the valve chamber 8 through the port 11. Inasmuch as the peripheral recess 18 laps the ports 11 and 12, the steam escaping from the former passes through the latter into the engine exhaust 14 and is thence conducted to the stack. The live steam from the supply pipe also enters the by-pass 19 and flows through the inlet port 10^a into the steam chest 3^a. Such steam is admitted to the cylinder 1^a to effect the operation of the piston 2 in substantially the same manner as just described for the cylinder 1, the exhaust steam passing off from the port 6 through the passage 15 into the engine exhaust 14.

Should it become desirable to operate the engine as a compound engine, the hand lever 23 is pulled to advance the valve so that the end of the by-pass 19 opening through the head 17^a is moved beyond the inlet port 10^a and is covered by the chamber wall. The recess 18 then laps the ports 11 and 10^a, while the port 12 is closed by the head 17, as illustrated in Fig. 3. The live steam from the supply pipe is then admitted to the steam chest 3 and after acting on the piston 2 of the cylinder 1, in this instance serving as a high pressure cylinder, the steam is exhausted from the steam chest 3 via the corresponding port 6 and the passage 13 and enters the valve chamber through the port 11. The steam is then conducted through the recess 18 and the port 10^a into the steam chest 3^a from which latter it is admitted to the low pressure cylinder 1^a and is thence exhausted through the passage 15 and leaves the engine finally through the main exhaust 14. It will therefore be observed that the engine is susceptible of being readily controlled by the operator and may be quickly converted from a simple double engine to a compound engine according as occasion requires. Furthermore, the engine may be positively

brought to a standstill by moving the intercepting valve to the position shown in Fig. 1, so that both ports 10 and 10^a are closed by the corresponding heads 17 and 17^a of the valve.

Attention is particularly directed to the fact that this engine is simple and durable in construction, positive in action, and consists of comparatively few parts that are not likely to get out of order.

Having thus described the invention what is claimed as new is:

In an engine, the combination of high and low pressure cylinders, pistons operating within the cylinders, a steam chest for each cylinder, valves arranged within the respective steam chests for controlling the admission of steam to the cylinders, an intercepting valve chamber positioned between the steam chests and provided at one end with a single inlet port leading to one of the steam chests and at the other end with a single inlet port leading to the other steam chest, the said valve chamber being also provided at a point between the inlet ports with a pair of ports which are in communication with the exhaust ports of the cylinders and with an exhaust duct leading to a point of discharge, a steam pipe leading into one end of the intercepting valve chamber, and a hollow intercepting valve open at one end thereof and slidable longitudinally in the valve chamber, the open end of the valve facing the steam pipe and the valve being provided at one end with a solid piston head and at its other end facing the steam pipe with an annular piston head and being formed intermediate of said heads with a peripheral recess adapted to span an adjacent pair of the before-mentioned ports, a port being provided in the head opposite to the open end of the valve for communication with one of the inlet ports, the valve having a length slightly greater than the distance between the inlet ports and being movable to control the ports for the purpose of admitting motive fluid to the steam chests simultaneously or successively for a simple or compound operation respectively.

In testimony whereof I affix my signature in presence of two witnesses.

ARTHUR B. WILMOT. [L. s.]

Witnesses:

F. A. WILMOT,
LAURA M. BOSLEY.