

(19) **DANMARK**

(10) **DK/EP 2780865 T3**



(12)

Oversættelse af
europæisk patentskrift

Patent- og
Varemærkestyrelsen

-
- (51) Int.Cl.: **G 06 K 7/14 (2006.01)** **G 06 K 19/06 (2006.01)**
- (45) Oversættelsen bekendtgjort den: **2017-07-03**
- (80) Dato for Den Europæiske Patentmyndigheds bekendtgørelse om meddelelse af patentet: **2017-03-15**
- (86) Europæisk ansøgning nr.: **11782434.2**
- (86) Europæisk indleveringsdag: **2011-11-15**
- (87) Den europæiske ansøgnings publiceringsdag: **2014-09-24**
- (86) International ansøgning nr.: **EP2011070186**
- (87) Internationalt publikationsnr.: **WO2013071960**
- (84) Designerede stater: **AL AT BE BG CH CY CZ DE DK EE ES FI FR GB GR HR HU IE IS IT LI LT LU LV MC MK MT NL NO PL PT RO RS SE SI SK SM TR**
- (73) Patenthaver: **Sicpa Holding SA, Av. de Florissant 41, 1008 Prilly, Schweiz**
- (72) Opfinder: **DECOUX, Eric, Rue du Jura 8, CH-1800 Vevey, Schweiz**
VUISTINER, Dave, Chemin des Libellules 8, CH-1010 Lausanne, Schweiz
- (74) Fuldmægtig i Danmark: **RWS Group, Europa House, Chiltern Park, Chiltern Hill, Chalfont St Peter, Bucks SL9 9FG, Storbritannien**
- (54) Benævnelse: **MØNSTER TIL KODNING AF DIGITAL INFORMATION PÅ EN OVERFLADE SÅVEL SOM FREMGANGSMÅDE TIL MÆRKNING OG LÆSNING**
- (56) Fremdragne publikationer:
WO-A1-2012/037985
FR-A1- 2 882 173
US-A- 5 809 160
US-A1- 2005 199 721

Description

The invention relates to the coding of numerical information on a surface by means of one or more patterns, in particular
5 two-dimensional patterns, in order to identify articles or security devices.

The invention also relates to the articles or security devices comprising such patterns, and the methods for marking and
10 reading these patterns on such articles or security devices.

Currently, articles and security devices can be identified by a mark or a logo inscribed on a package of the article or on the article itself. These inscriptions are visible and enable
15 the article to be identified by all users.

It is also possible to use other visible identifiers which contain encrypted information so that the content of the identifier cannot be recognized by all users. There are, for
20 example, one-dimensional identifiers of the barcode type or two-dimensional identifiers of the data matrix type, usually printed on a surface, and which are the most widely used.

The barcodes represent information using a pattern consisting
25 of bars with different thicknesses and spacings. However, these patterns can easily be decrypted.

Moreover, the identifiers of the "data matrix" type use white and black pixels forming an identification pattern and which
30 are arranged within the pattern in a rectangular or quadratic form. Such a data matrix is identified by two adjacent solid areas in the form of an "L", which as a whole is called "identifying pattern", and two edges formed by alternating white and black pixels, called "clock". The "L" shaped pattern
35 is used to locate and orient the identification pattern and the so-called "clock" pattern is used to count the number of columns and rows in the identification pattern. Furthermore, the "data matrix" also requires a so-called "blank" area,

sometimes called "quiet zone", for the identifying pattern to be detected. This so-called "blank" area is used to clearly isolate the identifying pattern from any other element of the article with which it might be confused.

5

However, these identifiers, visible to the user, notably through their identifying pattern and their detection area, must be marked in a chosen place on the article in order not to detract from its general appearance. Moreover, the identifying pattern is a known and constant pattern regardless of the article to be identified. This identifying pattern does not contain any information and is used only to detect the identification pattern.

15 Furthermore, these data matrices, despite being provided with error correction mechanisms, are not sufficiently robust because they depend on the substrate on which they are applied. In practice, depending on the unevennesses of the substrate, the latter may degrade the pattern when it is marked on the article. The robustness of such a pattern also depends on the print quality, because a printing defect, for example an ink which spreads or an absence of printing of a pixel, may greatly affect the pattern. In some cases, a data matrix with a dimension of 16 pixels by 16 pixels may also be rendered illegible by the destruction of more than six pixels. American patent application US2005/0199721 A1 relates to a two-dimensional barcode. This barcode is comprised of a plurality of rectangular elements arranged on a surface so as to form a rectangular barcode. Each rectangular element corresponds to a portion of encoded binary information and comprises a plurality of squares which are alternately white or black.

35 According to the present invention, there is proposed a pattern for coding a numerical information item which enhances the robustness of the identification of conventional articles or security devices.

There is also proposed a pattern for coding a numerical information item which is invisible to the user while being detectable by a suitable detection system.

5 Furthermore, there is a proposed a pattern for coding a numerical information item that can be printed and read even when the print quality is poor and also when the resolution used is fine, for example at least 300 dots per inch (DPI), preferably between 300 DPI and 600 DPI.

10

According to one aspect of the invention, there is proposed a pattern for coding a numerical information item on a surface according to Claims 1 to 7.

15 The symbols of the set of symbols may all be different.

As a variant, the symbols of the set of symbols are identical, in other words, the set of symbols comprises only one symbol comprising at least one differential pair of elements having
20 different parameter values.

In the present description a differential pair should be understood to be a pair of elements in which the first element can be characterized by a first value of a parameter and the
25 second element can be characterized by a second value of this parameter, different from the first value of the parameter. This parameter value difference may be any detectable difference, even if this difference cannot be detected by the naked eye.

30

The values of the parameters characterizing two elements of a differential pair may be respectively greater than and less than a first reference value and/or the difference between the two values may be greater than a second reference value.

35

An element should be understood to be a surface portion marked so as to assign it a value of a parameter capable of characterizing this surface portion by making its detection

possible relative to any adjacent or immediately adjacent surface portion. By way of nonlimiting example, the elements may be surface portions in the form of spots or localized reliefs, which may have an approximately circular contour. Obviously, other forms are possible. The elements may be produced by printing an ink on the surface, by calendaring, stamping or any other appropriate method.

The symbols may belong to a set of symbols, and they may correspond to a specific positioning of one or more differential pairs. In a symbol, the elements of a differential pair have a fixed relative position, but the parameter values of these elements are different.

Furthermore, in the present description, a specific arrangement of symbols comprising differential pairs is called a reference pattern.

Each symbol of the set of symbols may have at least one first representation and one second representation different from the first representation, the values of the parameters of the elements of at least one differential pair of the symbol both being different between the first representation and the second representation.

Said at least two representations of a symbol having a single differential pair are, for example, obtained by an arrangement of a differential pair in the configuration of the symbol and different parameter values for the two elements between the two representations.

Thus, since each symbol can be represented in its several representations, a same arrangement of symbols, or "pattern", can be represented in a number of different ways. Furthermore, the increase in the number of symbols, or the increase in the number of differential pairs of the symbols, makes it possible to considerably increase the number of marking possibilities for one and the same arrangement.

It will be noted that the coding pattern is illegible to a user who does not previously know the symbols used and their representations, and the arrangement of these symbols. Even if
5 a user could detect the elements marked on a surface, not knowing the symbols nor their "pattern" arrangement, it would be very difficult, or even impossible, for him or her to determine the symbols marked according to different representations. It is therefore almost impossible to retrieve
10 the numerical information coded by the coding pattern without knowing the symbols, the representations of the symbols, and their arrangement.

Furthermore, the coding pattern of the invention does not
15 require the use of a particular additional identifier of "L" shaped pattern, clock or even quiet zone type for its subsequent reading. Compared to a data matrix pattern, the coding pattern according to the invention does not include any specific detection area for the identification of the coding
20 pattern. It is the specific arrangement of the symbols that enables it to be identified.

It will be noted that the symbols of the coding pattern of the present invention are different from the symbols of a data
25 matrix: the symbols of a data matrix are in fact pixels, for example black or white, and not differential pairs of elements.

In one embodiment, the positioning of the first element and of
30 the second element of a differential pair of elements in a representation of a symbol is the reverse of the positioning of the first element and of the second element of the same differential pair of the same symbol in another representation.

35 In other words, the difference in the value of said parameter between the first element and the second element of said differential pair of the symbol in a representation may be

positive, and the difference in the value of said parameter between the first element and the second element of said differential pair of the symbol in another representation may be negative. The same may apply for all or some of the other
5 differential symbol pairs.

A differential pair of a symbol will thus comprise, in one representation, a first element having a high level (for said parameter), and a second element having a low level. In
10 another representation of the symbol, it is the first element which has a low level, and the second which has a high level. It will be noted that, in a preferred example, the average value of the parameter within the elements of the differential pair will be the same in both representations.

15 Obviously, for symbols comprising a number of differential pairs, one differential pair may be unchanged between two different representations if at least one other differential pair of the symbol is modified between these two
20 representations.

It will be noted that a set of symbols in which the parameter of the elements of the differential pairs can have only two values (or values in the vicinity of two different values)
25 makes it possible to form a pattern having a uniform appearance with respect to said parameter. The detection of the symbols is thus made all the more difficult, the symbols being difficult to discern.

30 Furthermore, the difference between the values of the parameters of the two elements of a differential pair may be greater than a first threshold (for example said second reference value) and less than a second threshold. Thus, the differential pairs of a representation of a symbol comprise
35 two elements each having a value of a parameter, and the difference in value between the two elements is greater than a first threshold and less than a second threshold.

As a variant, the values of the parameters of the two elements of a differential pair of elements are respectively greater than and less than the average value of said parameter within differential pairs neighbouring said differential pair.

5

Thus, when a differential pair is detected, it is possible to calculate the average value of the parameter in an area corresponding to the vicinity of the differential pair comprising, for example, a number of differential pairs or a number of marked elements, then the value of the parameter of each element of the pair concerned is compared to said average value. It is thus possible to check that the pair is in fact a differential pair, and then check which representation it corresponds to.

15

The elements can be chosen from the group comprising spots imprints and reliefs, and said parameter may be included in the group formed by the colorimetric components, the depth, the height, the electromagnetic absorption, the magnetic properties (for example the magnetic permeability or susceptibility), the shape, the quantity of ink used, the electrical conductivity, the luminescence (fluorescence and/or phosphorescence).

25

The colorimetric components may be the hue, the saturation, the lightness, known to those skilled in the art by the acronym "HSL" (Hue Saturation Lightness). Said parameter may be one of these components, for example the lightness for two elements of a black and white or even grey and dark grey differential pair. It is also possible to use another system, for example the red, green, blue system, well known to those skilled in the art by the acronym RGB.

30

The portion of said numerical information of the symbol may be a binary value defined by the representation of the symbol.

35

Thus, a differential pair of a symbol may correspond to one or more information bits whose value is defined, for example,

according to the sign and/or the amplitude of the difference between the value of the parameter of the first element of the differential pair and the value of the parameter of the second element of the differential pair. It is also possible to
5 assign a number of bits to a single differential pair of elements, for example by using a number of parameters. Moreover, the amplitude of the difference may be a numerical value comprising a number of bits.

10 The symbols of the pattern may define a binary value corresponding to said numerical information coded by the pattern.

It is also possible to define an order of reading of the
15 symbols arranged in a pattern to restore all the bits of the value coded by the pattern.

The pattern may be marked within an image comprising pixels, said elements being modified pixels of the image and said
20 parameter being at least one colorimetric pixel component.

According to another aspect, there is proposed an article or security device according to Claims 8 to 10 and comprising at least one pattern as defined above.

25 The article or security device may comprise a number of identical and/or different patterns.

By virtue of the repetition of the coding pattern, the
30 robustness with regard to its subsequent identification is improved. Because of the repetition of the pattern, the destruction or the degradation of a pattern does not prevent detection of the presence of at least one other pattern from all the patterns marked on the article. By using patterns that
35 have a uniform appearance, it is possible to mark a number of patterns without damaging the visual appearance of the article or of the security device.

The article or security device may be chosen from a label, a package, a cartridge, a container containing foodstuffs, nutraceutical products, pharmaceutical products or drinks, a bank slip, a credit card, a stamp, a revenue stamp, a tamper
5 indicator, a secure document, a passport, an identity card, a driving licence, an access card, a transport ticket, an admission ticket, a coupon, a printing form, a reflecting film, aluminium foil or a commercial article.

10 The article or security device may comprise at least one pattern marked within an image or a logo or a coded representation of another numerical information item chosen from the group formed by one-dimensional, two-dimensional or three-dimensional barcodes, scatterplots, networks of lines,
15 data matrices.

Thus, it is possible to code information in a representation coding another information item. As a nonlimiting example, it is possible to mark a pattern in the bars of a barcode, by
20 printing a pattern according to the invention with a resolution that is small enough to mark the elements having a different parameter value within a barcode bar.

It will also be noted that the surface marked may be concealed
25 under a layer of another material, for example under a layer of a plastic and/or polymeric film. It will thus be possible to read the pattern easily through such a layer of a plastic and/or polymeric film.

30 By marking a large number of small patterns, it would be possible to crease the marked surface (and/or a layer positioned on top) or to greatly alter it while retaining the possibility of reading at least one marked pattern. By contrast, the barcodes or data matrices used hitherto are
35 generally marked just once on an article, and an alteration makes them illegible.

According to another aspect, there is proposed a method for

marking a pattern for coding a numerical information item on a surface according to Claim 11.

The symbols of the set of symbols may be all different.

5

As a variant, the symbols of the set of symbols may all be identical, the set of symbols then comprising a single symbol.

10 The values of the parameters of two elements of a differential pair may be respectively greater than and less than a first reference value and/or the difference between the two values is greater than a second reference value.

15 For each symbol of the set of symbols, at least one first representation and one second representation different from the first representation may be defined, the values of the parameters of the elements of at least one differential pair of the symbol both being different between the first representation and the second representation.

20

The positioning of the first element and of the second element of a differential pair of elements in a representation of a symbol is the reverse of the positioning of the first element and of the second element of the same differential pair of the same symbol in another representation.

25

The difference between the values of the parameters of the two elements of a differential pair may be greater than a threshold.

30

As a variant, the values of the parameters of the two elements of a differential pair of elements are respectively greater than and less than the average value of said parameter within differential pairs neighbouring said pair.

35

The marking of the elements may comprise a printing or an etching or a deposition or a stamping or an application of a laser beam, and said parameter may be included in the group

formed by the colorimetric components, the depth, the height, the electromagnetic absorption, the magnetic properties, the shape, the quantity of ink used, the electrical conductivity, the luminescence (fluorescence and/or phosphorescence).

5

The portion of said numerical information item of the symbol may be defined as being a binary value defined by the representation of the symbol.

10 The symbols of the pattern may define a binary value corresponding to said numerical information item coded by the pattern.

The pattern may be marked within an image comprising pixels, 15 said elements being pixels of the image and said parameter being at least one colorimetric pixel component.

The method may also comprise, prior to the step for marking the elements on said surface, a creation of said differential 20 pairs of the symbols of the pattern comprising a measurement of at least one colorimetric component of two pixels of the image intended to form a differential pair of a symbol, a calculation of the difference in the measurement of the two pixels, a modification of the value of said at least one 25 colorimetric component of the two pixels if the difference is less than a threshold.

The modification of the value of said at least one colorimetric component of the two pixels comprises an increase 30 by an additional value of said value of a first pixel of the differential pair and a reduction by said additional value of a second pixel of the differential pair. Thus, the value of one pixel is increased by as much as that of the other pixel of the differential pair is reduced. The modification is 35 therefore made without changing the average value for the two pixels of the differential pair, and the image is preserved.

Obviously, the image may be a numerical image before being

marked in order to facilitate the modifications of the values of the pixels.

A surface of an article or of a security device may be marked.

5

A number of identical and/or different patterns may be marked on the article or security device.

The article or security device may be chosen from a label, a package, a cartridge, a container containing foodstuffs, nutraceutical products, pharmaceutical products or drinks, a bank slip, a credit card, a stamp, a revenue stamp, a tamper indicator, a secure document, a passport, an identity card, a driving licence, an access card, a transport ticket, an admission ticket, a coupon, a printing form, a reflecting film, aluminium foil and a commercial article.

It is possible to mark, on the article or security device, at least one pattern within an image or a logo, or a coded representation of another numerical information item chosen from the group formed by one-dimensional, two-dimensional or three-dimensional barcodes, scatterplots, networks of lines, data matrices.

According to yet another aspect, there is proposed a method for reading a numerical information item coded in a pattern marked on a surface according to Claim 12.

The symbols of the set of symbols may all be different.

30

As a variant, the symbols of the set of symbols may all be identical.

The term "image" should be understood to mean a two-dimensional representation of at least the value of the parameter within said area.

It will be noted that this reading method is different from an

optical character recognition (OCR) method in that the symbols, according to one aspect of the invention, are pairs of elements having a different parameter value, that is to say differential pairs. The symbols of a so-called "OCR" method do not comprise differential pairs of elements but a single form, that of the character to be recognized.

The identification of the symbols may also comprise a comparison of the value of the parameters of two marked elements of a differential pair to a first reference value and/or a comparison of the difference between the two values and a reference value.

Each symbol of the stored arrangement may have at least one first representation and one second representation different from the first representation, the values of the parameters of the elements both being different between the first representation and the second representation.

The positioning of the first element and of the second element of a differential pair of elements in a representation of a symbol may be the reverse of the positioning of the first element and of the second element of the same differential pair of the same symbol in another representation.

The identification of the symbols may also comprise a comparison to a threshold of the difference between the values of the parameters of the two elements of a differential pair.

As a variant, the identification of the symbols may also comprise a measurement of the average value of said parameter within differential pairs neighbouring a differential pair of elements and this average value is compared to the value of the parameter of each element of said differential pair.

Said parameter may be included in the group formed by the colorimetric components, the depth, the height, the electromagnetic absorption, the magnetic properties, the

shape, the quantity of ink used, the electrical conductivity, the luminescence (fluorescence and/or phosphorescence), and said captured image may comprise a representation of the value of this parameter on said area.

5

The portion of said numerical information item may be a binary value defined by the representation of the symbol.

The symbols of the pattern may define a binary value corresponding to said numerical information item coded by the pattern.

10

The pattern may be marked within an image comprising pixels, said elements being pixels of the image and said parameter being at least one colorimetric pixel component.

15

Said marked surface may be a surface of an article or security device and the marked surface may be a part or all of the surface of the security article or of the security device.

20

A number of identical and/or different patterns may be marked on the article or security device.

The article or security device may be included in the group formed by a label, a package, a cartridge, a container containing foodstuffs, nutraceutical products, pharmaceutical products or drinks, a bank slip, a credit card, a stamp, a revenue stamp, a tamper indicator, a secure document, a passport, an identity card, a driving licence, an access card, a transport ticket, an admission ticket, a coupon, a printing form, a reflecting film, aluminium foil and a commercial article.

30

The pattern may be marked on the article or security device within an image or a logo, or a coded representation of another numerical information item chosen from the group formed by one-dimensional, two-dimensional or three-dimensional barcodes, scatterplots, networks of lines, data

35

matrices.

According to yet another aspect, which is not part of the invention, there is proposed a system suitable for
5 implementing said marking method. This system may comprise processing means suitable for defining said specific arrangement and said coding pattern, for example a computer device, a device comprising a microprocessor and/or logic circuits and means for marking elements characterized by said
10 parameter on a surface.

According to another aspect, which is not part of the invention, there is proposed a system suitable for
15 implementing said reading method. This system may comprise a mobile telephone equipped with a camera, a tablet equipped with a camera, a portable or fixed camera, a portable or fixed scanner. As a general rule, this system may comprise means for storing said specific arrangement, a reading device having a reading window whose dimensions are at least equal to those of
20 the marked pattern, element identification means, means for identifying symbols.

According to another aspect, which is not part of the invention, there is proposed a use of said pattern for the
25 authentication of an article or security device.

Other advantages and features of the invention will become apparent from studying the detailed description of a few exemplary implementations and embodiments, which are in no way
30 limiting, and the appended drawings, in which:

- Figure 1 schematically illustrates an implementation of a creation of a pattern according to the invention,
- 35 - Figure 2 schematically illustrates another implementation of a creation of a pattern according to the invention,
- Figure 3 schematically illustrates an implementation of a

method for marking the pattern of Figure 1 on an article or security device,

5 - Figure 4 schematically illustrates an implementation of a method for reading an identification pattern applied to an article,

10 - Figure 5 schematically illustrates an embodiment of a pattern according to the invention,

- Figure 6 illustrates another implementation and embodiment according to the invention.

15 In the figures, the same references correspond to the same elements. The elements of the figures are not drawn to scale.

Figure 1 schematically shows an implementation of a creation S1 of an arrangement P1 of symbols according to the invention.

20 The symbols of the arrangement P1, denoted A, B, C and D, belong to a set of symbols ENS1.

25 The symbols A, B, C and D, four of them in this example (but there could obviously be more), comprise a differential pair of elements referenced E1 and E2 in the figure. The elements E1 and E2 are represented in the figure, by way of example and in order to give a better understanding of the invention through cross-ruled or shaded spots illustrating different values of a parameter, the parameter being, for example, the grey level. The cross-ruled spots E1 have, in the example illustrated, a parameter value greater than that of the shaded spots E2. In other words, the spots forming the elements E1 are darker than those forming the elements E2. The elements E1 and E2 thus form a differential pair according to the invention.

35 The respective position of the elements of a differential pair E1 and E2 defines the symbol (A to D).

In the example illustrated, the elements E1 and E2 of a differential pair are separated from one another by the approximate size of an element. Other positionings are possible. The two elements of a differential pair of a symbol may be close, and even in contact, or, on the other hand, further apart. The shape of the elements, in this case circular spot form, may also be different, for example rectangular, triangular or elliptical, in variants of the invention.

Furthermore, in the set of symbols ENS1, the symbols are all different and each of these symbols comprises two possible representations. The relative position of the elements of the differential pair is here unchanged for the two representations of a differential pair. Between two representations, the parameter values of the elements may change, or else the elements may be reversed, but their positioning in the differential pair and in the symbol will remain the same.

Thus, the symbol A comprises a differential pair of elements E1 and E2 positioned in a vertical arrangement in the two representations A1 and A2. In the first representation A1 of the symbol A, the element E1 which is a cross-ruled spot, is positioned above the element E2, which is a shaded spot. In the second representation A2, it is the element E2 which is above the element E1. Thus, the symbol A comprises a differential pair of elements positioned vertically and two representations in which the elements E1 and E2 have been reversed.

The symbol B also comprises a differential pair of elements E1 and E2, but positioned horizontally. In a first representation B1, the element E1 is to the left of the element E2, in a second representation B2, the element E1 is to the right of the element E2.

The symbol C comprises a differential pair of elements E1 and E2 positioned in a first diagonal direction. In a first representation C1, the element E1 is positioned above and to the left of the element E2, and in a second representation C2,
5 the element E1 is positioned below and to the right of the element E2.

Finally, the symbol D comprises a differential pair of elements E1 and E2 positioned in a second diagonal direction
10 opposite to said first diagonal direction of the symbol C. In a first representation D1, the element E1 is positioned above and to the right of the element E2, and in a second representation D2, the element E1 is positioned below and to the left of the element E2.

15

The four symbols A, B, C and D thus defined each with two representations define the set ENS1 with which the reference pattern P1 is created (S1).

20 It will be noted that the two representations of each symbol of the set ENS1 may define a bit of a binary value. As an example, the representations A1, B1, C1 and D1 correspond to the value 1, and the representations A2, B2, C2 and D2 correspond to the value 0.

25

The arrangement of symbols forming the reference pattern P1 may be created by arranging symbols of the set ENS1, without defining the representation of these symbols. In the example illustrated, the symbols are arranged in a rectangular area in
30 which the space is used so as to include a maximum number of symbols in this area. The symbols are, for examples, nested one inside the other and the elements of these symbols are aligned vertically and horizontally within the arrangement P1. It will be understood that, in the arrangement of symbols
35 forming the reference pattern P1, the symbols could be arranged in an area with a different geometrical shape, for example square, circular, elliptical, triangular or other.

In the example illustrated, a symbol A is positioned at the top right of the arrangement P1, an element of this symbol is positioned at the intersection of a horizontal axis X-X and of a vertical axis Z-Z, and an element is positioned at the intersection of a horizontal axis Y-Y, offset by approximately the dimension of an element E1 or E2 relative to the horizontal axis X-X and the vertical axis Z-Z. A symbol B may be positioned under this symbol A by aligning a right-hand element of this symbol B with the axis Z-Z. It is also possible to position a symbol B to the right of the symbol A whose two elements are then aligned with the axis X-X.

The reference pattern P1 comprises, in the example illustrated, 32 symbols of the set of symbols ENS1. Since each of these symbols has two representations, it is possible to create, in this example, $2^{32} = 4\ 294\ 967\ 296$ different reference patterns P1. Furthermore, by associating a bit with each symbol, 2^{32} binary values can be coded by means of this arrangement of symbols P1.

It will be noted that, by increasing the number of symbols of the reference pattern P1, the number of possible representations of the same pattern and the number of numerical values which can be coded by means of this pattern are increased. Generally, for a set of symbols each comprising a differential pair and having two representations, it will be possible to obtain, for a "pattern" having n symbols, 2^n different representations and values.

In order to use the "pattern" to coder a numerical value, it is necessary to assign a reading order to the symbols which make up the "pattern".

Thus, for a binary value comprising 32 bits, the so-called most significant bit (MSB) may be assigned to the symbol MSB1 of the pattern P1, here a symbol A positioned top left of the "pattern" P1. The so-called least significant bit (LSB) may be assigned to the symbol LSB1, here a symbol A arranged bottom

right of the "pattern" P1. The order in which the other bits are assigned may be, for example, from left to right and from top to bottom of the "pattern" P1. According to one aspect, it is also possible to assign a random order of the bits in which the successive bits are not adjacent.

An operation denoted S2 in the figure is used to create a pattern for coding numerical information comprising symbols belonging to the set ENS1 and arranged according to the reference pattern P1. Two possible examples of patterns M1 and M2 obtained by the operation S2 are represented. The patterns M1 and M2 correspond to two different numerical values. Obviously, the number of patterns Mn that it is possible to obtain by the operation S2 is not limited.

In the example illustrated, the most significant bit MSB1 of the value coded in the pattern M1 is equal to that of the value coded in the pattern M2 and here corresponds to a representation A1: 1. The second bit of these values, corresponding to the symbol SB2, a symbol B, is represented in the representation B1 within the pattern M1, and in the representation B2 within the pattern M2. Thus, the second bit of the value coded in the pattern M1 corresponds to a 1 and in the pattern M2 to a 0. Other symbols are represented in different representations for the two patterns M1 and M2, for example the symbols SB3 and SB4. The same may also apply for all the symbols of the different coding patterns obtained by the operation S2.

Figure 2 schematically shows another implementation of a creation S'1 of an arrangement of symbols or reference pattern P'1. In this example, the set of symbols ENS'1 comprises only a single symbol, but it could also comprise a number of different symbols.

The set of symbols ENS'1 here comprises a single symbol A' comprising two differential pairs of elements. The symbol A' comprises two differential pairs whose elements are aligned

horizontally and the differential pairs are positioned vertically.

The use of two differential pairs makes it possible notably to
5 define four representations. A representation A'1 is obtained
in which a differential pair PA'1 is positioned above a
differential pair PA'2. In the representation A'1, the
differential pair PA'1 and the differential pair PA'2 both
comprise an element E1 to the right, an element E2 to the
10 left. By modifying the respective positions of the elements E1
and E2 within the differential pairs PA'1 and PA'2 in the
representations A'2, A'3 and A'4, the other representations of
the symbol A' are obtained.

15 It will be noted that a reversal of the positioning of the
elements of one of the differential pairs in a representation
makes it possible to obtain another representation of the
symbol A' of the set ENS'1.

20 It will be noted that binary values can be assigned to these
representations. For example, the value 00 to the
representation A'1, the value 01 to the representation A'2,
the value 11 to the representation A'3 and the value 10 to the
representation A'4.

25 In this example, the set ENS'1 comprises only one symbol.
Obviously, in practice, it will be possible to provide a
greater number of symbols similar to the symbol A' and having
one or more differential pairs that can be arranged in
30 different ways.

In the operation S'1, it is possible to arrange a number of
symbols A' to form a reference pattern P'1. This "pattern"
comprises, in the example illustrated, 9 symbols, each capable
35 of coding two bits. It is therefore possible to code $2^{2 \times 9} =$
262 144 different values. These values can be coded by using
the following order of the symbols: VB1 (most significant),
VB2, VB3, VB4, VB5, VB6, VB7, VB8 then VB9 (least

significant).

In the example illustrated, in the operation S'2, two patterns M'1 and M'2 have been created, in which two different
5 numerical values are coded.

More specifically, the binary value
10 00 00 01 00 10 10 00 01 = 132 257 has been coded in the
pattern M'1 by following the order VB1 to VB9 and by using
10 binary values defined above for the representations A'1, A'2,
A'3, A'4. In the pattern M'2, the binary value
01 11 10 10 10 10 00 01 00 = 125572 has been coded. Obviously,
conventionally, it is possible to obtain characters by means
of these binary values, for example by using the ASCII code
15 system, well known to those skilled in the art.

Figure 3 schematically shows an implementation of a method for
marking an article or security device SUP using two patterns
M1 and M2 as illustrated in Figure 1, in which two different
20 numerical information items are coded.

This method comprises the step S1 for creation of an
arrangement of symbols or "pattern" P1 by means of a set of
symbols ENS1. The operation S2 is then implemented in order to
25 obtain a pattern M1 in which a numerical information item is
coded by means of the "pattern" P1 comprising 32 symbols.
Reference can be made to the description above concerning
Figure 1 for more details concerning the operations S1 and S2.
The pattern M1 and any other pattern also created by the
30 operation S2 can then be stored on a computing device.

The step S3 comprises a marking of the stored pattern M1, on
an article or security device SUP. The expression "marking"
can be understood to mean a printing, for example with visible
35 or invisible ink, an etching, a deposition, a stamping, a
calendaring, an application of a laser beam or any other
operation making it possible to position the coding pattern M1
and any other coding pattern on the article or the security

device. The article or security device SUP may be a label, a package, a cartridge, a container containing foodstuffs, nutraceutical products, pharmaceutical products or drinks, a bank slip, a credit card, a stamp, a revenue stamp, a tamper
5 indicator, a secure document, a passport, an identity card, a driving licence, an access card, a transport ticket, an admission ticket, a coupon, a printing form, a reflecting film, aluminium paper, a commercial article or, generally, an article or device that is to be furnished with a means of
10 identification or coded data that is difficult to identify without appropriate equipment.

The marking step S3 notably corresponds to a marking of the elements, E1 and E2 in the example illustrated, of the
15 differential pairs of the symbols A, B, C, D. It will be noted that the article or security device SUP has, on its outer surface or its package, a scattering of elements similar to those of the coding pattern M1 but not as a whole forming a coding pattern. There is no marking intended to form an
20 identifier on the article, only the elements of the differential pairs of the reference pattern M1 being marked on the article actually within the scattering of abovementioned undifferentiated elements. Thus, unlike the data matrices used in the prior art, all the marked elements correspond to a
25 coded value information item in a coding pattern. By using a fine resolution, for example of the order of several hundreds of elements per inch (Dots Per Inch, DPI), for example between 150 and 600 DPI or preferably between 300 and 600 DPI, it is possible to mark patterns according to the invention that will
30 not be detectable by a user but that only appropriate equipment comprising an electronic reading system will be able to detect and interpret. Such a resolution also makes it possible to mark a plurality of small patterns: the marking of the information is thus particularly robust because an
35 alteration of one or even several patterns will not render all patterns illegible. The use of such a fine resolution also makes it possible to prevent the reproduction of a pattern, for example by means of a photocopier.

In order to make a pattern according to the invention undetectable to the naked eye, it is also possible to mark patterns with parameter values that are similar (notably the values of the elements of a differential pair). More specifically, it is possible to choose parameter values that a human eye cannot discern but that an appliance can detect. It is also possible to use a coarse resolution, for example wider than 150 DPI, without in any way enabling a user to discern different elements that make up a pattern. Obviously, the pattern as a whole, or a plurality of adjacent patterns, may be visible to a user, who will see only a uniform area, for example uniformly coloured.

It will be noted that the pattern M1 can be marked within a graphic element of the article or security device SUP, this graphic element possibly being an image or a logo, or a coded representation of another numerical information item, for example of one-dimensional, two-dimensional or three-dimensional barcodes, of scatter plots, of networks of lines or of data matrices.

As a nonlimiting example, it is possible to mark patterns according to the invention in the bars of a barcode.

25

In the example illustrated, simultaneously with the marking step S3, a certain number of other additional elements EADD of type E1 or E2 were marked outside the pattern M1. In the example illustrated, the additional elements EADD form a row surrounding the pattern M1. The additional elements are here aligned with the elements of the pattern M1, which is a way of making it difficult to read the coding pattern M1. The additional elements may also be more numerous, in numbers very much greater than the number of elements that form the coding pattern M1, and have different positionings.

35

These additional elements EADD may form part, for example, of a graphic area of the security article or of the security

device. The additional elements EADD may also serve to embed the coding pattern M1 to make it all the more difficult to detect. Since these additional elements are not arranged in the form of differential pairs in a reference pattern, they will not falsify the reading of the numerical information coded in the coding pattern M1. It will also be understood that these additional elements EADD may preexist on the article, in which case there is no need to proceed with their marking during the step S3.

5

In all cases, it may be advantageous to choose a representation of the elements E1 and E2 which approximates as closely as possible the representation of the additional elements EADD so as to make the detection and the reading of the coding pattern M1 more difficult.

10

It will be noted that a number of means can be used to make the marked pattern all the more undetectable to the naked eye. For example, it is possible to use an ink whose chemical nature makes it invisible to the naked eye but simply visible under specific lighting, for example using infrared or ultraviolet light. The composition of these inks may comprise one or more pigments and/or dyes which absorb in the visible or invisible of the electromagnetic spectrum and/or may comprise one or more pigments and/or dyes that are luminescent. Nonlimiting examples of appropriate pigments and/or of dyes that absorb in the visible or invisible of the electromagnetic spectrum include, by way of nonlimiting example, the derivatives of phthalocyanine but also the derivatives of perylene, quaterylene type, substituted or not. Nonlimiting examples of appropriate luminescent pigments and/or dyes comprise the derivatives of lanthanides. The presence of pigment(s) and/or of dye(s) makes it possible to enhance and strengthen the security of the marking against counterfeiting. Some compounds mentioned above make it possible to confer traceability and/or authentication properties on the marking according to the invention. In fact, these particular compounds differ from the conventional inks

15

20

25

30

35

and their detection, for example by chemical or physical analysis means, may make it possible to determine the origin of the marked product.

5 It is also possible to mix the marked coding pattern or patterns with a noise, for example by incorporating the coding pattern in an environment of the surface of the article or security device SUP including irregularities or preexisting spots. These irregularities or these spots should preferably
10 have a size and an appearance that are comparable to the size and the appearance of the marked coding patterns.

The coding pattern M1 marked on the article or security device SUP, and any other additional coding pattern created in a
15 similar way, may make it possible to code an information item enabling the security article or the security device SUP to be authenticated or even an information item relating to the use of the security article or of the security device SUP.

20 It will be noted that using a set of symbols each comprising similar elements, and a reference pattern comprising a high number of symbols makes it possible to obtain a marking that has a uniform appearance, in which it is not possible to read the coded information without knowing the symbols, the
25 representations of the symbols and the reference pattern used. Moreover, the use of differential pairs comprising two element having two possible parameter values such as the elements E1 and E2 illustrated here by way of example, makes it possible to obtain a pattern comprising as many elements E1 as elements
30 E2, and therefore, a uniform appearance of the outer surface of the article or of the security device.

It is possible to mark a number of coding patterns according to the invention on the article or security element SUP. It is
35 possible to mark a number of identical patterns and also a number of different patterns. It is also possible to cover a surface of the article or security element SUP.

As a nonlimiting example, it is possible to mark coding patterns according to the invention over the entire surface of a package, intended to cover an object. The reading of the coding patterns can then be implemented on the basis of any surface portion of the package covering the object. It will be possible for example to mark substantially transparent plastic films, or also opaque films of aluminium foil type. It will also be possible, using appropriate marking means, to mark coding patterns according to the invention on very rough or non-uniform surfaces, for example wine bottle stoppers or even on the corresponding seal.

Moreover, certain articles that are marketed, for aesthetic reasons or constraints associated with their production, have little space available to support a marking. The marking according to the invention makes it possible to overcome these constraints. In practice, the pattern or patterns can be marked on supports having a reduced surface while remaining invisible to the naked eye, while retaining the reading robustness according to a method of the invention.

Figure 4 shows an implementation of a method for reading numerical information coded in a coding pattern according to the invention, marked on a surface of an article or security device SUP.

Before the reading is implemented, a set of symbols, for example the set ENS1 already mentioned by way of example with reference to Figure 1 or the set ENS'1 already mentioned by way of example with reference to Figure 2, and one or more arrangements of symbols or reference patterns, are stored in a memory of a reading system.

Then, in the example illustrated, the method comprises a step D1 in which an image of an area Z01 of a surface of an article SUP is captured. The system suitable for implementing the step D1 may comprise a reading device such as a fixed or portable reader or scanner, a camera, a telephone equipped with a

digital camera, a tablet equipped with a digital camera, and, generally, any means suitable for making the marked elements visible, for example lamps radiating in the infrared or ultraviolet ranges. The image obtained is then stored.

5

An element identification step D2 is then implemented. It will notably be possible to identify the elements according to the knowledge of the symbols of a set of symbols, for example the set ENS1. For symbols whose elements are spots of varying shapes (for example, the symbols of the set ENS1 illustrated in Figure 1), a plurality of elements, for example of type E1, E2, are detected within the image obtained in the step D1. Furthermore, it is possible to measure, for each element, a parameter value and store the measured values.

15

Then, in the step D3, the symbols can be identified by means of a stored reference pattern, for example the arrangement of symbols P1 illustrated in Figure 1. Since the area Z01 may include additional elements, for example additional elements EADD, the identification of the symbols may comprise a number of steps up to the identification of the symbols of the coding pattern or patterns by means of the single reference pattern stored.

25

There now follows a description of a simplified example of implementation of this identification with reference to the example of Figure 1, it being understood that the procedure would be similar in the case of the example of Figure 2. We can begin by matching the arrangement of symbols P1 with a first group of elements GEL through a study window of the reading device which comprises this group of elements GEL (comprising a group of 64 elements positioned in a grid). By matching the arrangement of symbols P1, that is to say the stored reference pattern, with the group of elements GEL, it will be noted that a certain number of pairs of symbols of the group GEL corresponding to the arrangement of symbols P1 are not differential pairs. The pairs ND1 and ND2 comprise pairs of elements arranged as two pairs of symbols of the

30

35

arrangement P1, but these pairs are not differential pairs. In practice, they respectively comprise two elements E2 and two elements E1. In both cases, there is no parameter difference between the two elements. It will be noted that two different
5 elements do not always form a differential pair. It is in particular a good idea to measure the difference between the two parameter values of the two elements, to compare it to a threshold, or to measure the difference between each parameter value and an average value.

10

The study window of the reading device may have a size at least equal to that of a marked coding pattern. The study window may notably have dimensions (width and height) which are twice those of a marked coding pattern.

15

It is therefore possible to use the parameter values obtained in the step D2 to determine whether the pairs of elements are differential pairs. It will also be possible to compare the difference between the values to a stored threshold, or even
20 to check whether the values of each parameter are respectively greater than or less than another value, for example an average value. This average value may be stored previously or be measured and calculated in the step D1 or in the step D2 by observing the surface of the article.

25

The non-differential pairs ND1 and ND2 obtained by matching the arrangement of symbols P1 with the group of elements GEL shows that the elements of the group of elements GEL do not form a coding pattern comprising symbols arranged according to
30 the arrangement or reference pattern P1.

The reading device or the study window is then displaced relative to the article to match the reference pattern P1 with another group of elements, for example the group of elements
35 IM1 (Figure 4). All the elements of the group IM1 correspond to differential pairs of elements of symbols arranged according to the reference pattern P1. It will be noted for example that the differential pair PD1 corresponds to the

symbol corresponding to the most significant bit MSB1, the differential pair PD2 corresponds to the symbol SB2, the differential pair PD3 corresponds to the symbol SB3, the differential pair PD4 corresponds to the symbol SB4 and the differential pair PD5 corresponds to the symbol corresponding to the least significant bit LSB1.

It is then estimated that the coding pattern has been found within the group of elements IM1. It will be noted that, by browsing over the groups of elements marked on the article or the security device SUP and by matching the reference pattern P1 with groups of elements, a representation of a coding pattern coding a numerical information item has been found, and without using any coordinate system indicating the placement of the coding pattern on the article.

It will be noted that it is possible not to require the recognition of all the symbols of the reference pattern P1. It is possible in this case to calculate the number of symbols identified, and compare this calculated number to a probability threshold. If the calculated number is greater than this threshold, it can be estimated that a coding pattern produced by means of a reference pattern according to the invention is present. The pattern is thus very robust, an alteration of symbols of a pattern not preventing the recognition of the reference pattern and reading of the symbols which have not been damaged.

As a nonlimiting example, for a reference pattern comprising 128 symbols, a probability threshold can be taken that is of the order of 30 symbols identified out of 128, that is to say 24%. Other probability thresholds can be used, it is possible in particular to choose a high threshold in order to determine with certainty that the coding pattern is identified.

Finally, once the symbols have been identified as indicated previously, the information coded by the marked elements forming a coding pattern can be read in a step D4. This

reading can be done only with a knowledge of the order of reading of the arrangement of symbols. The order defined hereinabove can be used, in which the reading is conducted from top to bottom and from left to right. The knowledge of the set of symbols and of their respective representations makes it possible to detect the binary values associated with the marked symbols. The parameter values measured in the step D2 are used to determine the representation used. The reading of the binary value of each symbol makes it possible to determine the binary value coded in the marked coding pattern.

The step D4 may also comprise conventional error correction steps in order to determine the representations of the symbols that have not been identified.

Furthermore, in the implementation of the reading method, a margin of displacement in height and in width can be tolerated for each marked element. As a nonlimiting example, slight diameter differences in the elements do not affect the reading. Nor do slight positional differences affect the reading.

There now follows a more detailed description, referring more particularly to Figures 5 and 6, of a variant of the invention.

Figure 5 shows a coding pattern PCO in which an information item is coded according to an arrangement of eight symbols in which the elements of the symbols are differential pairs of image pixels. The eight symbols are arranged in a matrix of 4x4 pixels. Each pixel is characterized by a parameter which may be the one of the colorimetric components. The symbols of this pattern PCO thus each comprise differential pairs of elements similar to the symbols of the set ENS1 of Figure 1, but in which the elements are pixels.

Furthermore, the pairs of pixels are differential pairs whose representation is defined by the values of a colorimetric

component, for example the hue, the saturation or the lightness, of each of the pixels of the differential pair. More specifically, one of the pixels of the differential pair has a high value denoted H and the other has a low value denoted L. By reversing the respective position of these levels, different numerical information can be coded.

The coding pattern PCO is intended to be included in an image, as illustrated in Figure 6. In this figure, an initial image IMGI is represented which conventionally comprises a plurality of pixels and a group of 16 pixels GPI forming a 4x4 matrix of pixels. It is within the group of pixels GPI that the coding pattern PCO will be included. The initial image IMGI may be a digital image, stored in a memory and modifiable by processing means, for example equipped with a microprocessor and/or logic circuits. Once modified to include the coding pattern PCO, this image may be marked on a surface of a security article or element.

Each pixel of the group of pixels GPI has a value of a chosen colorimetric component denoted V_{IJ} , I ranging from 1 to 4 indicating the column of the pixel in the 4x4 matrix, and J ranging from 1 to 4 indicating the row of the pixel in the 4x4 matrix. It is then possible to check whether each pair of pixels in the group of pixels GPI corresponds to a differential pair according to the pattern PCO.

By comparing the value of the pixels V_{11} and V_{22} of the pair of pixels PC_1 , if V_{11} is greater than V_{22} and if the difference between the two values is less than a threshold, in the group of pixels GPI, then it is necessary to modify the value of the colorimetric component of these pixels, for example by increasing V_{11} and by reducing V_{22} by the same value to obtain the modified pixels V'_{11} and V'_{22} of the modified image IMG_M.

The increase and the reduction by the same value is particularly advantageous; thus, the average value of the

parameter within the pair PC1 is the same for the values V11 and V22 and for the values V'11 and V'22.

5 Other pairs of pixels can thus be modified. For example, the pixels of the pair PC4 can have values V24 and V34 but V24 may be greater than V34. In other words, V24 corresponds to a high value and V34 to a low value. In order to mark the pair PC4 of the pattern PC0, the values of the pixels can be reversed, and the values V'24 and V'34 are obtained. It is also possible to
10 reverse, increase and reduce as above, the values of the pixels, for example the values of the pixels of the pair PC6, to obtain the values V'42 and V'43.

The values of the pixels of the remaining pairs of the group
15 of pixels GPI have not been modified, because the values of the pixels of the initial image may also already correspond to differential pairs of the coding pattern PC0.

Thus, within the modified image IMG_M (here marked on an
20 article or security device SUPC), the pattern PC0 has been marked by modifying the values of pixels of the initial image IMG_I. The modifications of pixel values are imperceptible to a user, since they are applied at neighbouring pixels in images that may comprise millions of pixels.

25

It will be noted that it is also possible to use other colorimetric components, for example components of the Red-Green-Blue system.

30 Moreover, in order to determine whether, in a pair of pixels, one has a high value and the other has a low value, it is possible to compare these values to an average value obtained by a calculation of the value of the component for a number of neighbouring pixels. It is also possible to calculate an
35 average value relating to another component. As a nonlimiting example, the red level of the neighbouring pixels of a differential pair may define the average value or a threshold to which the values of the pair are compared.

There is also proposed a system suitable for implementing a marking method, for example the method of Figure 3. In one embodiment, this system may comprise a memory configured to store a set of symbols, an arrangement of these symbols forming a reference pattern, and numerical information to be coded. The system may comprise means for marking on a surface of an article or a security device, for example means for printing, etching, stamping, calendaring, deposition, application of a laser beam or any other method making it possible to modify portions of the surface concerned. These marking means can make it possible to mark elements invisible to the naked eye.

There is also proposed a system suitable for implementing a reading method, for example the method of Figure 4. This system may comprise means for storing an arrangement of symbols forming a reference pattern and a set of symbols, and means suitable for capturing an image such as a camera, a fixed or portable reader or scanner, a portable telephone equipped with a camera, a tablet equipped with a camera, means for revealing the marked elements such as a lamp radiating in the ultraviolet or in the infrared, and processing means suitable for identifying the elements and the symbols on the basis of the captured image comprising, for example, a microprocessor and/or logic circuits.

It will be noted that, according to one aspect, the coding patterns obtained may be used to authenticate an article, and thus enhance its traceability and detect counterfeit articles. It is also possible to mark information relating to the use of the article.

A marking of coding patterns according to the invention has a particularly high robustness. It will be possible to mark patterns by using a fine resolution, for example 300 DPI, so as to obtain patterns that individually have a size less than a square millimetre, in order, finally, to cover a surface for

example of the order of one or more square centimetres. Obviously, other resolutions and dimensions are possible.

5 As a nonlimiting example, such coding patterns according to the invention can be marked on a surface of the order of a square centimetre. These patterns may be visible overall or invisible for a user. The entire marked surface may have dimensions that are, for example, similar to a data matrix. In the case where the patterns are visible, they may have a
10 uniform appearance for a user, or equally be embedded in an image.

Any alteration of the marked surface will not prevent the detection of the reference pattern used, nor the reading of
15 the numerical information coded in the patterns. The surface may, for example, have been altered by means of a pen or a pencil, it may have been creased, folded, scratched or torn. Such alterations may have been combined without preventing the reading of the numerical information coded in the patterns.

20

By contrast, such alteration processes applied to conventional markings of barcode or data matrix type would make the reading of the information contained in these markings totally impossible.

Patentkrav

1. Mønster til kodning af en digital information på en overflade, der omfatter et specifikt arrangement (P1, P'1) af
5 et antal symboler, som tilhører et sæt af symboler (ENS1), hvor hvert symbol i arrangementet er bestemt til kodningen af en del af den nævnte digitale information, hvilket mønster er kendetegnet ved, at hvert symbol består af mindst ét
10 differentielt par af elementer (E1, E2), der er anbragt på en specifik måde, hvor hvert element er kendetegnet ved en parameter, hvilken parameter for det første element i hvert af de differentielle par har en første værdi, og parameteren af det andet element i hvert af de differentielle par har en anden værdi, som er forskellig fra den første værdi, og ved,
15 at det specifikke arrangement svarer til en forudbestemt arrangement af de nævnte symboler, som danner et referencemønster.

2. Mønster ifølge krav 1, hvori symbolerne i sættet af
20 symboler alle er forskellige eller identiske.

3. Mønster ifølge ethvert af de foregående krav, hvor værdierne af parametrene for de to elementer (E1, E2) af et
25 differentielt par er henholdsvis større end og mindre end en første referenceværdi og/eller forskellen mellem de to værdier er større end en anden referenceværdi.

4. Mønster ifølge ethvert af de foregående krav, hvor hvert symbol af sættet af symboler har mindst en første
30 repræsentation (A1, B1, C1, D1) og en anden repræsentation (A2, B2, C2, D2), der er forskellig fra den første repræsentation, hvilke værdier af parametrene for elementerne i mindst et differentielt par af symbolet begge er forskellige mellem den første repræsentation og den anden repræsentation.

35

5. Mønster ifølge krav 4, hvori placeringen af det første element og det andet element af et differentielt par af elementer i en repræsentation af et symbol er det modsatte af

placeringen af det første element og det andet element i det samme differentielle par af det samme symbol i en anden repræsentation.

- 5 6. Mønster ifølge ethvert af kravene 3 til 5, i hvilket forskellen mellem værdierne af parametrene for de to elementer i et differentielt par er større end eller mindre end en tærskelværdi.
- 10 7. Mønster ifølge ethvert af kravene 3 til 6, i hvilket værdierne af parametrene for de to elementer i et differentielt par af elementer er henholdsvis større end og mindre end den gennemsnitlige værdi af de nævnte parametre inden for differentielle par, der er naboer til det nævnte
15 differentielle par.
8. Sikkerhedsartikel eller indretning (SUP), der omfatter mindst ét mønster ifølge ethvert af de foregående krav.
- 20 9. Artikel eller sikkerhedsanordning ifølge krav 8, der omfatter et antal identiske og/eller forskellige mønstre.
10. Artikel eller sikkerhedsanordning (SUP) ifølge et af kravene 8 og 9, der omfatter mindst et mønster, der er
25 markeret inden i et billede eller et logo, eller en kodet repræsentation af en anden digital information, der er valgt fra gruppen dannet af endimensionale, todimensionale eller tre-dimensionale stregkoder, punktdiagrammer, netværk af linjer, og datamatricer.
- 30 11. Fremgangsmåde til at markere et mønster til kodning af en digital information på en overflade, kendetegnet ved, at den omfatter følgende trin:
- 35 - at definere et specifikt arrangement eller referencemønster af et antal symboler, der tilhører et sæt af symboler (ENS1), hvor hvert symbol i arrangementet er bestemt til kodningen af en del af den nævnte digitale information, hvor hvert symbol består af mindst et par elementer, der er anbragt på en

specifik måde,

- at skabe et mønster til kodning den nævnte digitale information ved hjælp af det specifikke arrangement eller referencemønster af et antal symboler, ved at give hvert symbol en specifik repræsentation, således at hvert symbol består af mindst et differentielt par af elementer, hvor hvert element er kendetegnet ved en parameter, hvilken parameter for det første element har en første værdi og parameteren af det andet element har en anden værdi, der er forskellig fra den første værdi,
- at tilvejebringe en overflade,
- at markere et antal elementer (E1, E2) på overfladen, hvilke elementer hver er kendetegnet ved den nævnte parameter, hvilket trin til at markere antallet af elementer udføres på en sådan måde, at visse markante elementer danner kodningsmønstret for den digitale information.

12. Fremgangsmåde til læsning af en digital information, der er kodet i et kodningsmønster, som er markeret på en overflade, der omfatter markerede elementer, som hvert er kendetegnet ved en parameter, hvilken fremgangsmåde er kendetegnet ved, at den omfatter følgende successive trin:
- a) at lagre et specifikt arrangement eller referencemønster (P1) af et antal symboler, der tilhører et sæt af symboler (ENS1), hvor hvert symbol i arrangementet er bestemt til at kode for en del af den nævnte digitale information, hvor hvert symbol består af mindst et differentielt par af elementer, der er anbragt på en specifik måde, hvilken parameter for det første element i hver differentielt par har en første værdi, og parameteren af det andet element i hvert differentielt par har en anden værdi, der er forskellig fra den første værdi,
 - b) at opfange et billede af et område af overfladen, der indbefatter en gruppe af mærkede elementer, i et undersøgelsesvindue af en læseenhed,
 - c) at bringe det gemte referencemønster i overensstemmelse med gruppen af markerede elementer,
 - d) at måle afvigelsen mellem parameterverdierne for de to elementer af par af symboler i gruppen af markerede elementer

for at afgøre, om det drejer sig om differentielle par,

e) hvis ikke, bevæges aflæsningsvinduet relativt i forhold til overfladen, der omfatter markerede elementer, og der opfanges et billede af et andet område af overfladen, som indbefatter

5 en anden gruppe af markerede elementer,

f) trinnene (c) og (d) gentages, indtil et bestemt antal af elementer i gruppen af afmærkede elementer svarer til differentielt par, der er arrangeret ifølge det lagrede referencemønster,

10 g) herefter aflæses den digitale information, der er kodet af elementerne i det markerede kodende mønster, der er fundet inden for en gruppe af mærkede elementer.

13. Fremgangsmåde ifølge krav 12, hvor antallet af symboler, 15 der er identificeret, beregnes og resultatet af beregningen sammenlignes med en tærskelværdi for sandsynligheden.

14. Fremgangsmåde ifølge et af kravene 12 og 13, hvor 20 identifikationen af symbolerne også omfatter en sammenligning af værdierne af parametrene for to markerede elementer af et differentielt par til en første referenceværdi og/eller en sammenligning af forskellen mellem de to værdier og en referenceværdi.

25 15. Fremgangsmåde ifølge ethvert af kravene 12 til 14, hvor identifikationen af symbolerne omfatter en sammenligning med en tærskelværdi for forskellen mellem værdierne af parametrene for de to elementer af et par af elementer.

FIG. 1

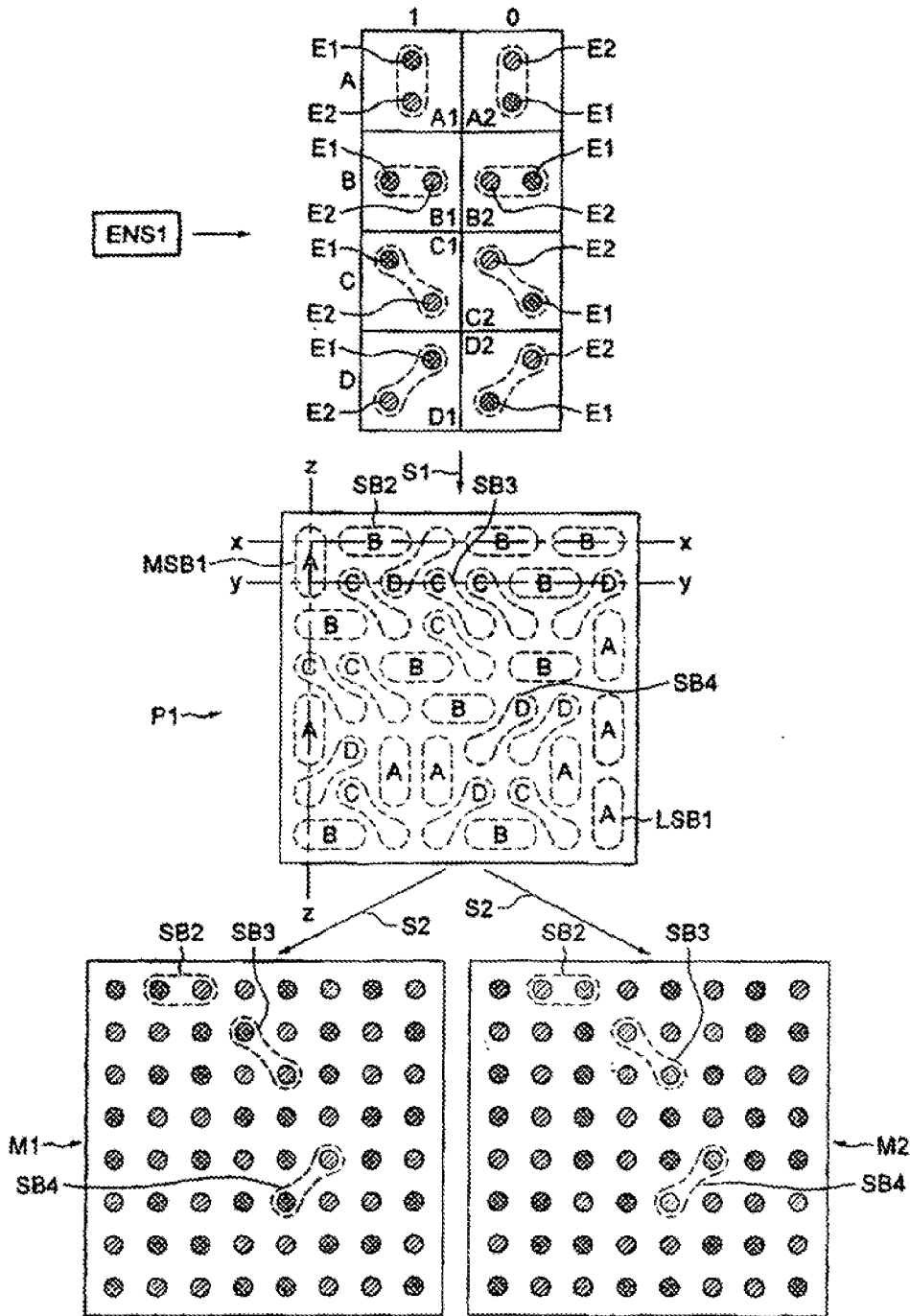

FIG.2

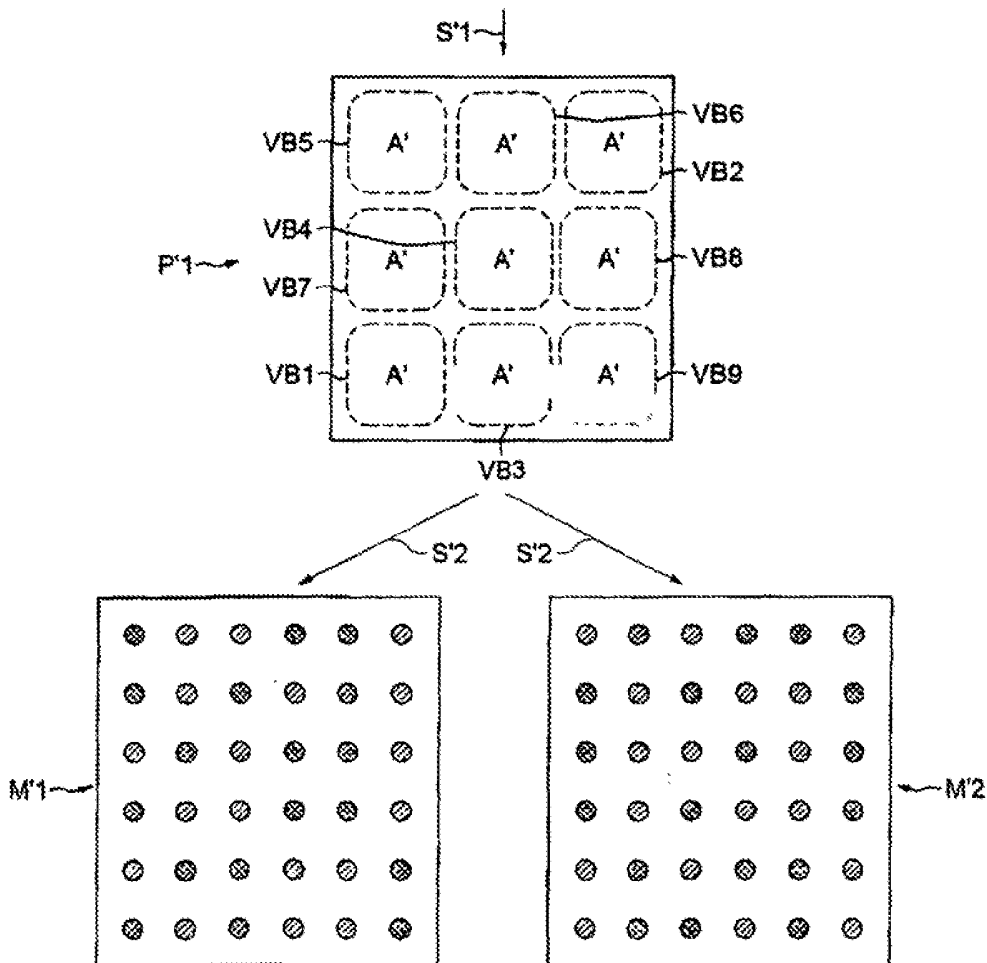
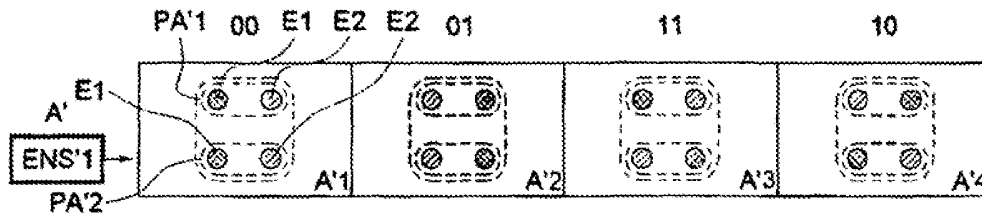

FIG.3

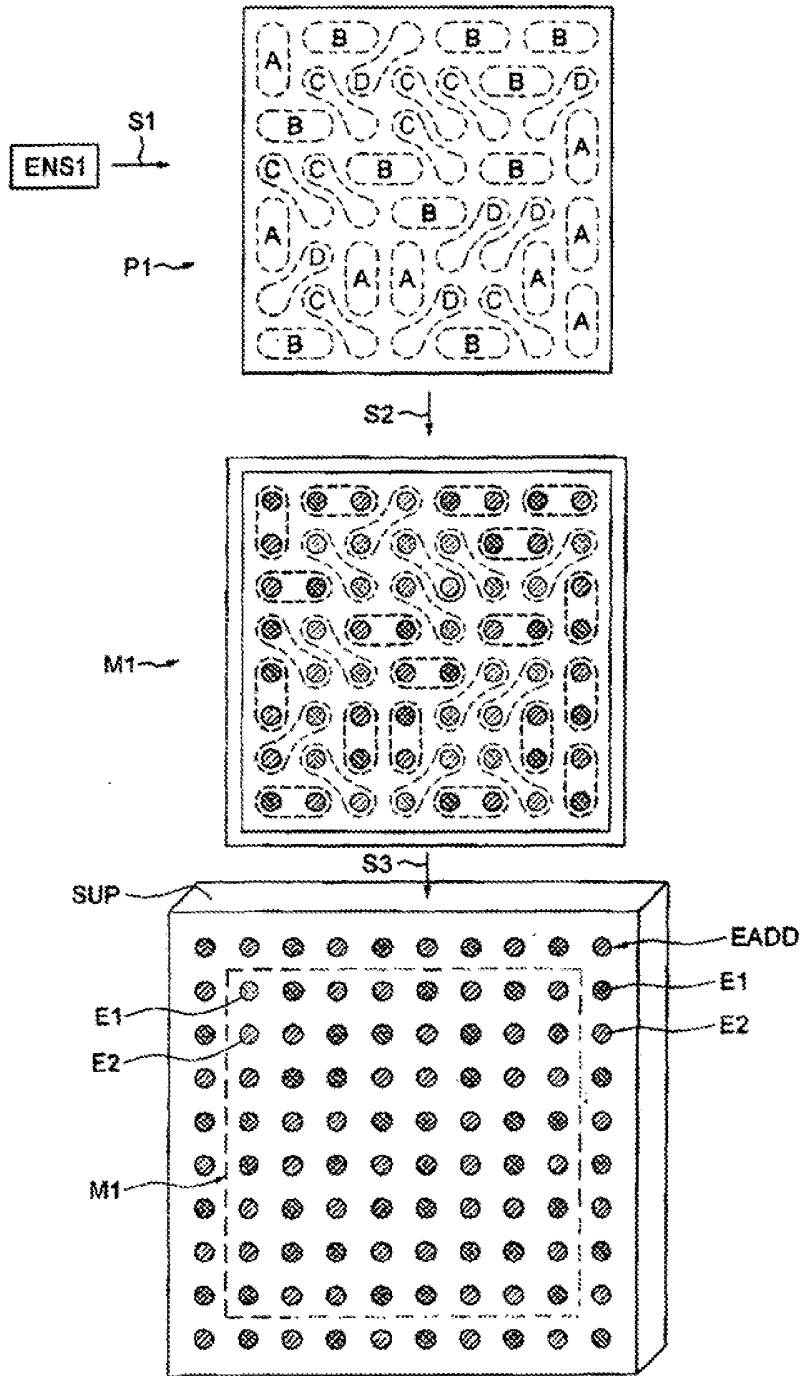

FIG.4

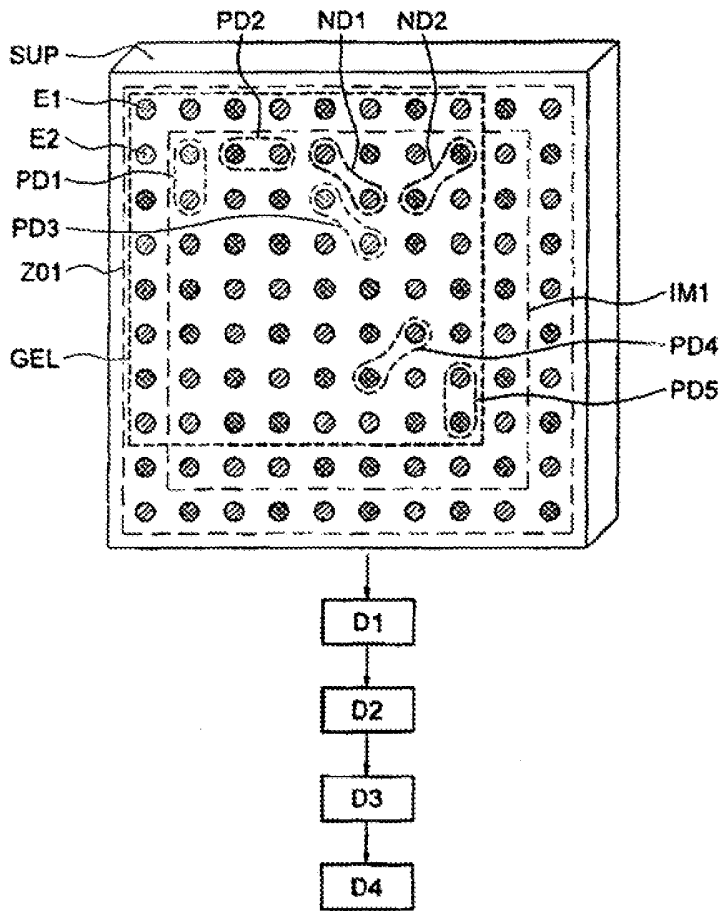

FIG.5

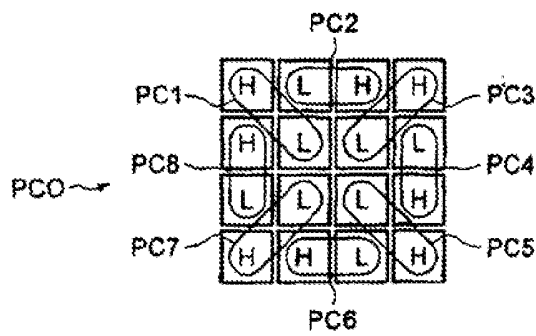

FIG.6

