

No. 830,554.

PATENTED SEPT. 11, 1906.

T. E. ADAMS.  
ENGINE OR TENDER TRUCK.  
APPLICATION FILED MAY 10, 1906.

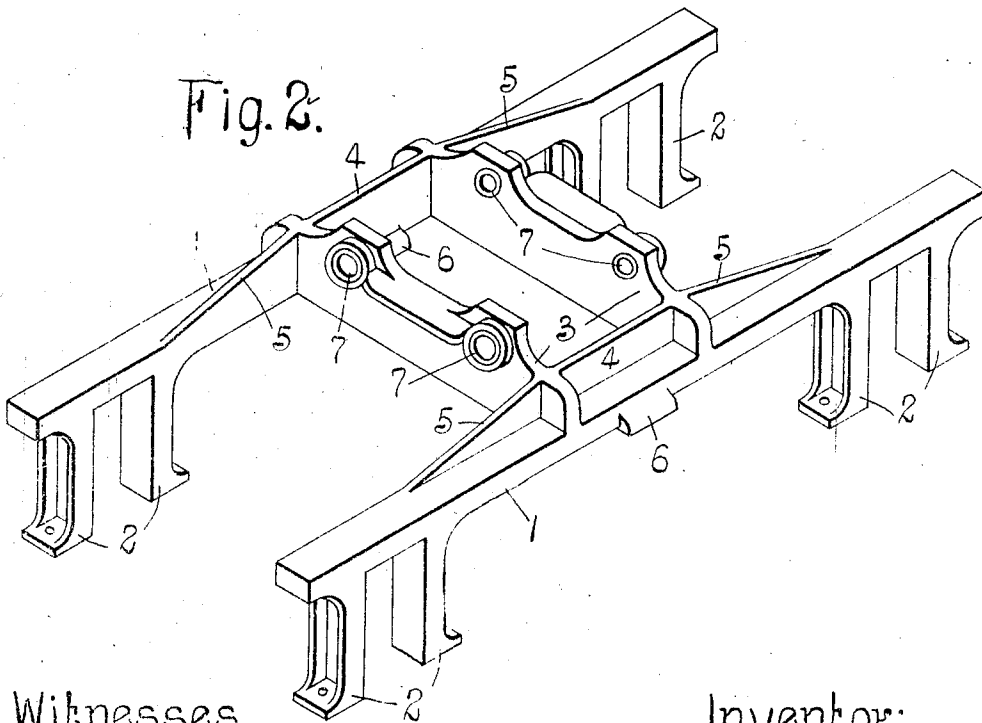
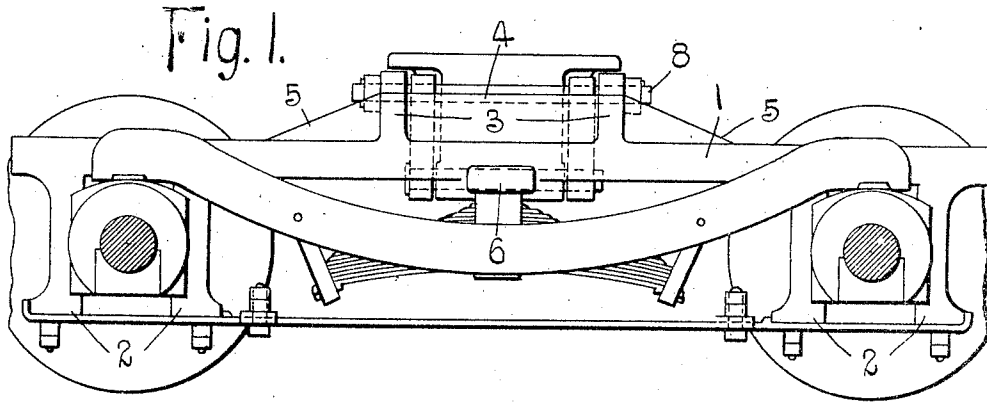

Witnesses

*Edgar J. Farmer*  
*Nells L. Church.*

Inventor:

Thomas E. Adams  
by *Baker & Cornwall*  
Atty's.

# UNITED STATES PATENT OFFICE.

THOMAS E. ADAMS, OF PINE BLUFF, ARKANSAS, ASSIGNOR OF ONE-HALF  
TO CHARLES H. SEABROOK, OF PINE BLUFF, ARKANSAS.

## ENGINE OR TENDER TRUCK.

No. 830,554.

Specification of Letters Patent.

Patented Sept. 11, 1906.

Application filed May 10, 1906. Serial No. 316,157.

*To all whom it may concern:*

Be it known that I, THOMAS E. ADAMS, a citizen of the United States, residing at Pine Bluff, Arkansas, have invented a certain new and useful Improvement in Engine or Tender Trucks, of which the following is a full, clear, and exact description, such as will enable others skilled in the art to which it appertains to make and use the same, reference being had to the accompanying drawings, forming part of this specification, in which—

Figure 1 is a side elevation of an engine-truck embodying the features of my invention assembled with the wheels, springs, equalizer, &c.; and Fig. 2 is a perspective view of the truck with the parts which cooperate therewith removed.

This invention relates to engine and tender trucks; and the object of my invention is to provide an engine or tender truck that can be manufactured at a much lower cost than the trucks heretofore in use and which will be more rigid and last much longer than said trucks. Accordingly I have devised a truck which is formed, preferably, of cast-steel with the pedestals integral with the side frames and the side frames formed integral with the center-bearing frame, thereby reducing greatly the cost of manufacture and eliminating the possibility of any of said members working loose.

Referring to the drawings, which show the preferred form of my invention, 1 designates the side frames of the truck, having pedestals 2 formed integral therewith, these pedestals being preferably of channel form. The ends of the cross members 3 of the center-bearing frame extend flush with the outer faces of the side frames and are formed integral with the side frames, and strengthening-webs 4 are located intermediate said cross members, said webs projecting upwardly from the side frames. Tapered webs 5 also project upwardly from the side frames and merge into the cross members of the center-bearing, thereby producing a very rigid construction which possesses great strength. The spring-seats 6 are formed integral with the side frames, and the cross members 3 of the center-bearing frame are preferably provided with

removable steel bushings 7, which receive the pins 8, that support the center-bearing casting. Although I have used the term "engine-truck" in the claims, it should be understood that this same construction is well adapted for a tender-truck.

Having thus described my invention, what I claim as new, and desire to secure by Letters Patent, is—

1. A cast-steel engine-truck comprising side frames which consist of straight members having pedestals formed integral therewith, and a frame for a swinging center-bearing consisting of transversely-extending straight members which rest on the upper faces of the side frames and are formed integral therewith; substantially as described.

2. A cast-steel engine-truck comprising side frames which consist of straight members having pedestals formed integral therewith, and a frame for a swinging center-bearing consisting of transversely-extending straight members which rest on the upper faces of the side frames and are formed integral therewith, and strengthening-webs projecting upwardly from the side frames and merging into the transversely-extending members which constitute the center-bearing frame; substantially as described.

3. A cast-steel engine-truck comprising side frames consisting of straight members having channel-shaped pedestals formed integral therewith, a center-bearing frame consisting of straight cross members which extend flush with the outer faces of the side frames and are formed integral therewith, webs projecting upwardly from said side frames between said cross members with which they are formed integral, and upwardly-projecting tapered webs on the side frames merging into the cross members of the center-bearing frame; substantially as described.

In testimony whereof I hereunto affix my signature, in the presence of two witnesses, this 8th day of May, 1906.

THOMAS E. ADAMS.

Witnesses:

WELLS L. CHURCH,  
GEORGE BAKEWELL.