

Feb. 2, 1971

C. E. SWAYZE

3,559,234

CORNER TOOL AND APPLICATOR NOZZLE

Filed Jan. 8, 1969

2 Sheets-Sheet 1

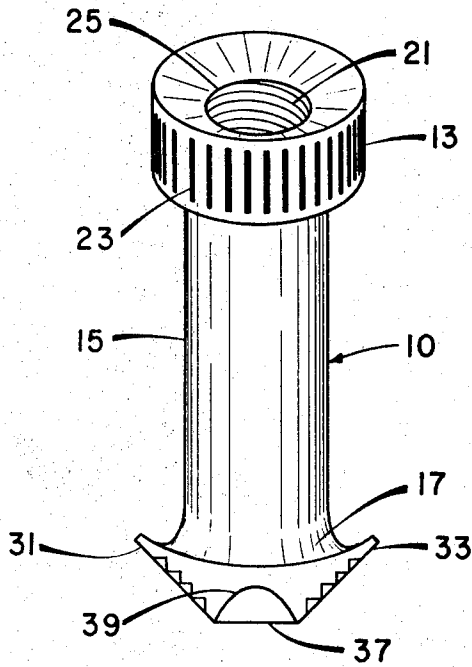

Fig. 1

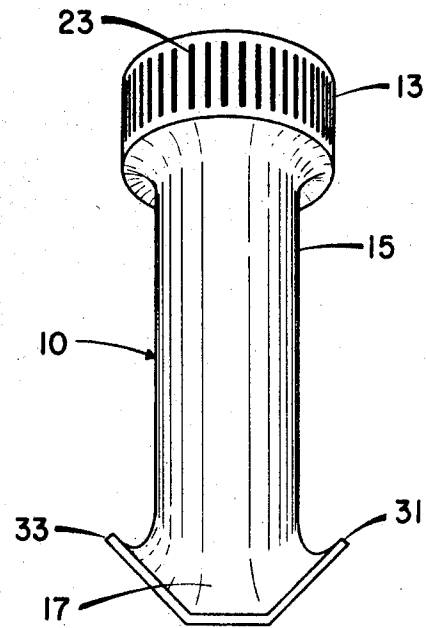

Fig. 2

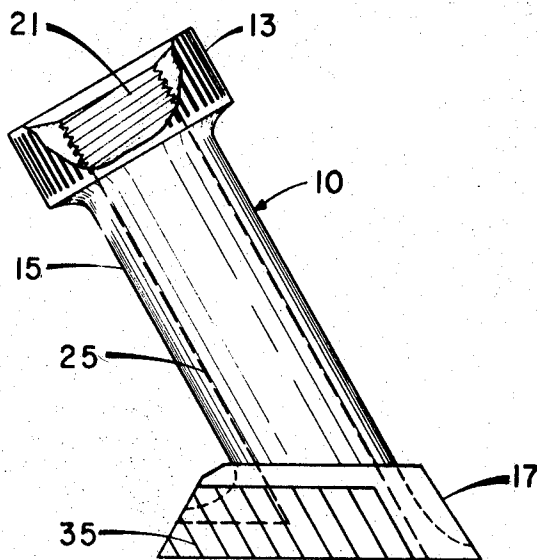

Fig. 3

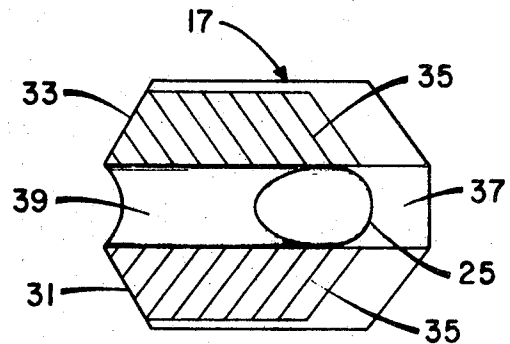

Fig. 4

INVENTOR

CLARK E. SWAYZE

BY *Howard W. Hervey*

ATTORNEY

Feb. 2, 1971

C. E. SWAYZE

3,559,234

CORNER TOOL AND APPLICATOR NOZZLE

Filed Jan. 8, 1969

2 Sheets-Sheet 2

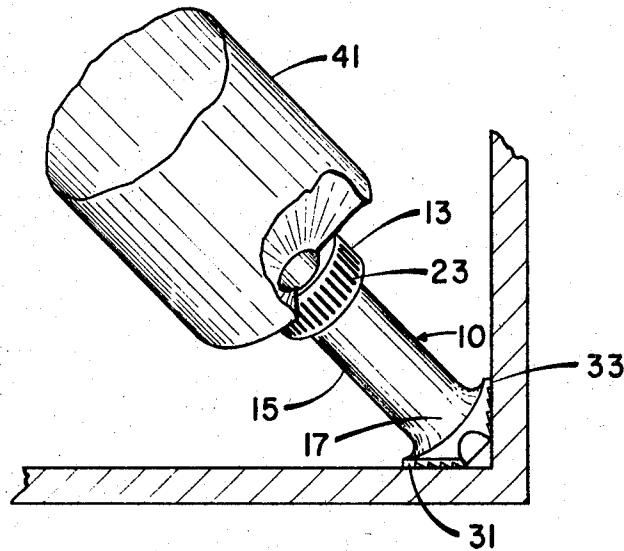

Fig. 5

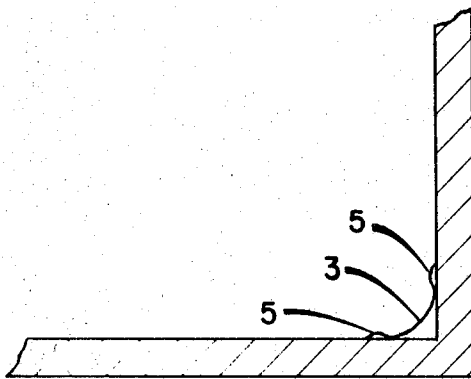

Fig. 6

(PRIOR ART)

INVENTOR
CLARK E. SWAYZE
BY *Howard W. Newman*
ATTORNEY

1

3,559,234
CORNER TOOL AND APPLICATOR NOZZLE
Clark E. Swayze, Midland, Mich., assignor to
Dow Corning Corporation, Midland, Mich.
Filed Jan. 8, 1969, Ser. No. 789,814
Int. Cl. E04f 21/28

U.S. Cl. 18—3.5

10 Claims

ABSTRACT OF THE DISCLOSURE

A combination corner finishing tool and fluid applicator nozzle adapted to be removably mounted on the discharge nozzle of a dispensing tube is disclosed. The applicator nozzle has two legs which are perpendicular to each other and have cross ribs or fins on their outer surfaces which serve to scrape clean a surface which the legs are moved along. When one leg of the nozzle is held against one of two perpendicular surfaces, the other leg of the nozzle automatically is flush against the second surface. Thus, the nozzle is especially suited for dispensing caulking materials. As the nozzle is guided along the seam between a wall and a bathtub, for example, the caulking material is dispensed into the seam and smoothed to a predetermined angle to the wall and bathtub.

BACKGROUND OF THE INVENTION

This invention relates to fluid applicators, and the like, and more particularly to devices of this character adapted for ready attachment to the discharge nozzle of a dispensing tube; the dispensing tube functioning as a handle for the applicator.

Generally, adhesives, sealants and caulking compounds are applied to seams between surfaces perpendicular to each other by means of a simple, conical-shaped nozzle mounted on the discharge end of a dispensing tube. Such nozzles can be a permanent member of the dispensing tube, or they can be removably mounted on its discharge nozzle. Further, some such nozzles have stepped surfaces or sections which can easily be cut off to provide a desirable diameter for the discharge orifice of the nozzle.

These conical-shaped nozzles are used by pushing them and their respective dispensing tubes along the seam to be worked on. Thus, as the adhesive, sealant or caulking compound is dispensed into the seam, the lower surface of the tip of the nozzle smooths or trowels the dispensed material. In most instances, as illustrated in FIG. 6 of the accompanying drawing, the conical-shaped nozzle tends to furrow a concave path or surface 3 on the applied material leaving extraneous parallel streams or stripes 5 of the applied material on the surfaces along the entire length of the seam.

These extraneous streams or stripes are unsightly and do not give the seam the finished look that generally is desired. Thus, much time and effort is generally spent removing these streams or stripes, to the extent that is possible.

However, even if it is possible to remove those extraneous streams or stripes, when a material such as a silicone caulking compound has been applied to the seam, difficulty is experienced in trying to paint over the area which had been covered by the stripes. That is, it is impossible to remove a stripe of such a silicone caulking compound from a surface without rubbing some of that compound

2

into the surface. Thus, the area where the stripe had been cannot be satisfactorily painted, since paint does not adhere to, but rather, forms beads on surfaces bearing a silicone material.

5 Additionally, such conical nozzles are difficult to maintain in the exact same alignment with a seam between two perpendicular surfaces along the entire length of that seam. Thus, the smoothed bead of material discharged into the seam frequently will vary in thickness, relative position on the surfaces and seam, and angle of inclination between the surfaces. These variances are unsightly and therefore undesirable.

SUMMARY OF THE INVENTION

15 The primary object of the present invention, therefore, is to provide an improved means for applying and spreading a fluent material to a seam between substantially perpendicular surfaces, which means will be free from the aforementioned and other disadvantages of prior devices of this type.

20 More particularly, it is an object of the present invention to provide a combination applicator nozzle and tool which can be used for applying an aesthetically attractive bead of fluent material to a seam between substantially perpendicular surfaces and which will not leave extraneous beads or stripes on those surfaces.

25 Another object is to provide a combination applicator and tool which can be removably mounted on the discharge nozzle of a dispensing tube and can be easily aligned with the seam between substantially perpendicular surfaces.

30 In accordance with these and other objects, there is provided by the present invention a combination corner finishing tool and fluid applicator nozzle adapted to be removably mounted on the discharge nozzle of a dispensing tube, which consists essentially of an integral head, neck and base having a continuous aperture there-through. The base thereof includes means for automatically aligning the nozzle with a seam between perpendicular surfaces, means for scraping clean a portion of those surfaces, and means for troweling or smoothing material applied to the seam through the nozzle.

BRIEF DESCRIPTION OF THE DRAWING

35 Other objects and advantages will become obvious to those skilled in the art by reading the following detailed description in connection with the accompanying drawings wherein:

40 FIG. 1 is a front view in elevation of the tool and nozzle of the present invention;

45 FIG. 2 is a rear view in elevation of the device shown in FIG. 1;

50 FIG. 3 is a right side view in elevation of the device shown in FIG. 1, showing in cross-section threads in the head thereof;

55 FIG. 4 is a bottom view of the base of the device shown in FIG. 1;

60 FIG. 5 is a view in elevation showing the device of FIG. 1 attached to a dispensing tube and in alignment with the seam between two perpendicular surfaces shown in cross-section; and

65 FIG. 6 is an end view of two perpendicular surfaces showing a bead of material and two extraneous stripes of the same material formed on those surfaces by a prior art caulking nozzle.

DESCRIPTION OF THE PREFERRED EMBODIMENTS

Referring now to the drawings wherein like reference numerals designate like or corresponding parts throughout the figures thereof, there is shown in FIG. 1, a combination corner tool and applicator nozzle, shown generally as **10**, which consists essentially of three parts: a head **13**, a neck **15** and a base **17**. The entire tool and nozzle **10** can be formed as one integral piece. Accordingly, the tool and nozzle **10** can advantageously be formed by injection molding, or any other convenient method of molding.

The head **13** is preferably cylindrical and provides a means by which the tool and nozzle **10** can be removably mounted on the discharge nozzle of a dispensing tube. Since most such discharge nozzles are externally threaded, the head **13** preferably has a set of internal threads **21** which are complementary to the external threads on such discharge nozzles. However, the head **13** can bear other means for being removably mounted onto a discharge nozzle if desired, e.g., complementary flanges, grooves or diameters.

Additionally, the external surface of the head **13** can be provided with flanges or grooves to provide a grippable surface thereon. FIGS. 1 and 2 show flanges **23** on the head **13**. Likewise, such flanges or grooves can also be provided on the neck **15**.

The head **13** is joined to the base **17** by a preferably cylindrical neck **15**. A continuous aperture **25**, best seen in FIG. 3, passes longitudinally through the head, neck and base. Obviously, the aperture **25** is the channel or path along which material will flow when discharged from a dispensing tube on which the tool and nozzle **10** is mounted.

To align the aperture **25** with the seam between two substantially perpendicular surfaces, the base **17** is provided with legs **31** and **33**. The exterior or outside surfaces of the legs **31** and **33** are respectively defined by one of two intersecting perpendicular planes converging in the direction from the head **13** to the base **17**. The line of intersection of the above-described perpendicular planes also lies in a plane longitudinally bisecting the head **13** and neck **15** of the tool and nozzle **10**. Preferably, the angle between either of the perpendicular planes and the plane longitudinally bisecting the head **13** and neck **15** is 45 degrees.

As can best be seen in FIG. 4, the outer surfaces of the legs **31** and **33** preferably bear cross ribs or fins **35**. These cross ribs or fins **35** clean any excess or overflowing material from the perpendicular surfaces while the tool and nozzle **10** is moved forwards along those surfaces.

The tool and nozzle **10** is preferably made by injection molding of a non-sticking or low-friction material, such as polyethylene, nylon or Teflon. When the tool and nozzle **10** is so formed, the base **17** can be made thin enough to be flexible. Thus, when two surfaces are not exactly perpendicular, the flexible base **17** will flex to conform to those surfaces and thereby still automatically align the aperture **25** with the seam between those surfaces.

The base **17** is defined or subtended on its bottom side by a substantially flat or planar surface **37** on the rear or back side of the aperture **25**. This planar surface **37** forms the tool portion of the tool and nozzle **10** and preferably is flat, although a small amount of curvature therein can be tolerated. Further, the planar surface **37** preferably subtends the base **17** at a 45 degree angle to each of the legs **31** and **33**. This allows the tool and nozzle to smooth the dispensed material to the same angle when it is moved forwards along a seam with the front end of its base **17** pointed in either direction.

On the forward or front side of the aperture **25**, the bottom of the base **17** is defined or subtended by a grooved surface **39** which rises toward the head **13** and extends from the outer surface of one of the legs **31**

and **33** to the outer surface of the other. The grooved surface **39** serves as a means for shaping a bead of the material to be dispensed through the aperture **25** into a seam from a dispensing tube.

As is illustrated in FIG. 5, when it is desired to use the tool and nozzle **10** to dispense material into a seam between perpendicular surfaces, it is mounted on the discharge nozzle of a dispensing tube **41**. Accordingly, the dispensing tube **41** can be used as a handle for moving the tool and nozzle **10**. One leg of the base **17** is then held against one of the perpendicular surfaces forming the seam and the other leg being perpendicular to the first leg is therefore automatically flush against the other surface forming the seam.

When the material is then discharged from the dispensing tube **41** and the tube **41** and nozzle **10** moved along the seam, the material will be laid down as an even corner bead into the seam between the two perpendicular surfaces. This bead is then shaped by the inner surfaces of the legs **31** and **33** and smoothed to a predetermined angle to the surfaces by the tool **37**. Obviously, the front of the nozzle **10**, or the grooved surface **39**, would be the leading portion of the nozzle as it is moved along. Any excess material which does manage to escape from the groove formed by the surface **39** is immediately scraped from the perpendicular surfaces by the cross fins **35** on the legs **31** and **33**.

When the tool and nozzle **10** has been made from one of the non-sticking materials as aforementioned, it moves smoothly and easily along the surfaces. Further, the use of these non-sticking materials allows the tool and nozzle **10** to be easily and quickly cleaned of the material applied to the seam, once the job is completed.

Having now described the invention in specific detail and exemplified the manner in which it may be carried into practice, it will be readily apparent to those skilled in the art that innumerable variations, applications, modifications and extensions of the basic principles involved may be made without departing from its spirit or scope.

That which is claimed is:

1. An applicator nozzle and corner tool adapted for attachment to the discharge nozzle of a dispensing tube, comprising:

a head removably mountable on said discharge nozzle,

a neck,

a base adjoined to said head by said neck and including two legs, each leg having its outer surface respectively defined by one of two intersecting perpendicular planes converging in the direction from said head to said base and intersecting in a plane longitudinally bisecting said head and neck, said head, neck and base having a continuous longitudinal aperture therethrough, and

said base being subtended on a first side of said aperture by a substantially planar surface between said perpendicular planes and subtended on the side of said aperture opposite said first side by a grooved surface rising toward said head; starting in one said perpendicular plane and terminating in said other perpendicular plane, which grooved surface defines the inner surfaces of said legs.

2. The article as defined in claim 1, wherein the plane defining the outer surface of each said leg intersects the plane longitudinally bisecting said head and neck at a 45 degree angle.

3. The article as defined in claim 1, wherein said head of said nozzle and tool bears a set of threads complementary to a set of threads on said discharge nozzle of said dispensing tube.

4. The article as defined in claim 1 and further comprising: longitudinal flanges on the external surface of said head.

5. The article as defined in claim 1, wherein said head and said neck are cylindrical.

5

6. The article as defined in claim 1 and further comprising: cross fins on the outer surface of each said leg for scraping clean a surface along which said leg is moved.

7. The article as defined in claim 1, wherein said legs are flexible. 5

8. The article as defined in claim 1, wherein said substantially planar surface subtends said perpendicular planes at a 45 degree angle to each said plane.

9. The article as defined in claim 1, wherein said article is made from polytetrafluoroethylene, 10

6

10. The article as defined in claim 1, wherein said article is made from polyethylene.

References Cited

UNITED STATES PATENTS

2,594,606	4/1952	Ames	-----	18-3.5
2,804,767	9/1957	Schoen	-----	18-3.5X
3,267,516	8/1966	Eckhaus	-----	18-3.5

H. A. KILBY, Jr., Primary Examiner