



- (51) International Patent Classification:
A45D 1/04 (2006.01)
- (21) International Application Number:
PCT/US2015/011773
- (22) International Filing Date:
16 January 2015 (16.01.2015)
- (25) Filing Language: English
- (26) Publication Language: English
- (30) Priority Data:
61/928,359 16 January 2014 (16.01.2014) US
- (71) Applicant: CONAIR CORPORATION [US/US]; One
Cummings Point Road, Stamford, CT 06902 (US).
- (72) Inventor: LEUNG, Anthony, Kit Lun; Flat B, 6/f, Block
12, Braemar Hill Mansion, 37 Braemar Hill Road, North
Point, 06468, Hong Kong (CN).
- (74) Agents: SCHMIDT, Joseph, W. et al.; Carter, Deluca,
Farrell & Schmidt, LLP, 445 Broad Hollow Road,
Melville, NY 11747 (US).
- (81) Designated States (unless otherwise indicated, for every
kind of national protection available): AE, AG, AL, AM,

AO, AT, AU, AZ, BA, BB, BG, BH, BN, BR, BW, BY,
BZ, CA, CH, CL, CN, CO, CR, CU, CZ, DE, DK, DM,
DO, DZ, EC, EE, EG, ES, FI, GB, GD, GE, GH, GM, GT,
HN, HR, HU, ID, IL, IN, IR, IS, JP, KE, KG, KN, KP, KR,
KZ, LA, LC, LK, LR, LS, LU, LY, MA, MD, ME, MG,
MK, MN, MW, MX, MY, MZ, NA, NG, NI, NO, NZ, OM,
PA, PE, PG, PH, PL, PT, QA, RO, RS, RU, RW, SA, SC,
SD, SE, SG, SK, SL, SM, ST, SV, SY, TH, TJ, TM, TN,
TR, TT, TZ, UA, UG, US, UZ, VC, VN, ZA, ZM, ZW.

- (84) Designated States (unless otherwise indicated, for every
kind of regional protection available): ARIPO (BW, GH,
GM, KE, LR, LS, MW, MZ, NA, RW, SD, SL, ST, SZ,
TZ, UG, ZM, ZW), Eurasian (AM, AZ, BY, KG, KZ, RU,
TJ, TM), European (AL, AT, BE, BG, CH, CY, CZ, DE,
DK, EE, ES, FI, FR, GB, GR, HR, HU, IE, IS, IT, LT, LU,
LV, MC, MK, MT, NL, NO, PL, PT, RO, RS, SE, SI, SK,
SM, TR), OAPI (BF, BJ, CF, CG, CI, CM, GA, GN, GQ,
GW, KM, ML, MR, NE, SN, TD, TG).

Published:

— without international search report and to be republished
upon receipt of that report (Rule 48.2(g))

(54) Title: AUTOMATIC HAIR CURLING APPLIANCE WITH FLUID VAPOR EMISSION

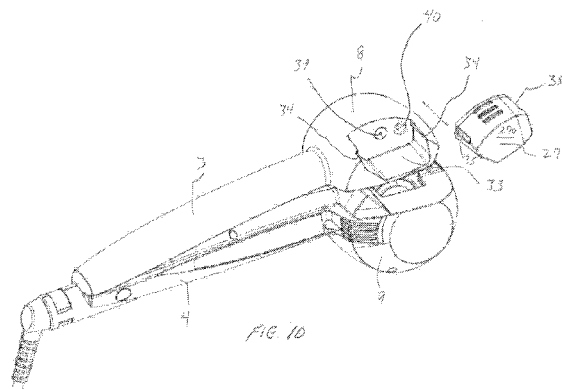

(57) Abstract: A hair styling apparatus includes a first handle member having a first body defining an internal chamber dimensioned to receive a length of hair and a second handle member having a second body. The second handle member is adapted for movement relative to the first handle member between an open position and a closed position. An elongate member is positioned within the internal chamber of the first body of the first handle member. A rotatable component is mounted to the first body and adapted for rotatable movement to engage the length of hair within the internal chamber and wrap a segment of the hair about the elongate member. A cartridge is releasably mountable to the second handle member, and contains a hair treatment agent. A heater is in fluid communication with the cartridge for at least partially heating the treatment agent dispensed from the cartridge. At least one port in fluid communication with the heater and positioned to direct the treatment agent from the heater onto the hair disposed adjacent or within the internal chamber of the first handle member.



AUTOMATIC HAIR CURLING APPLIANCE WITH FLUID VAPOR EMISSION**CROSS REFERENCED TO RELATED APPLICATION**

[0001] This application claims priority to, and the benefit of, U.S. Provisional Application Serial No. 61/928,359, filed January 16, 2014.

TECHNICAL FIELD

[0002] The present disclosure relates to a hair styling apparatus, and more particularly, to hair styling apparatus for curling hair.

BACKGROUND

[0003] Hair styling devices for styling or curling hair are known in the art. For example, U.S. Patent Nos. 8,651,118 ('118 patent), 8,733,374 ('374 patent) and 8,869,808 ('808 patent), each disclose a hair styling device which includes a rotatable component for wrapping hair about a guide member. Other known hair styling devices are disclosed in U.S. Design Patent D696,456 and U.S. Patent No. 8,607,804. Each of these patents is incorporated herein by reference in its respective entirety. The presently disclosed hair curling apparatus shares some features of select embodiments of the hair styling devices described in the patents identified above. In addition, the presently disclosed hair curling apparatus includes a mechanism or system for dispensing a treatment agent on the hair, such as, e.g., a steam generator and emitting system, to emit steam to enhance styling and/or curling of hair.

SUMMARY

[0004] Accordingly, the present disclosure relates to a hair styling apparatus including a first handle member having a first body defining an internal chamber dimensioned to receive a length of hair and a second handle member having a second body. The second handle member is adapted for movement relative to the first handle member between an open position where the first and second bodies are displaced and a closed position where the first and second bodies are approximated. An elongate member is positioned within the internal chamber of the first body of the first handle member. A rotatable component is mounted to the first body and adapted for rotatable movement to engage the length of hair adjacent or within the internal chamber and wrap a segment of the hair about the elongate member. A cartridge is mountable to one of the first and second handle members. The cartridge includes a hair treatment agent for dispensing on, and treating, the hair disposed adjacent or within the internal chamber of the first handle member.

[0005] The hair styling apparatus may include a heater for heating the hair treatment agent. The cartridge may be releasably mountable to the second body of the second handle member. The second body may include the heating element. In embodiments, the heating element is dimensioned to at least partially vaporize the hair treatment agent. The hair treatment agent may be water which converts to steam when subjected to the heating element for application to the hair to enhance styling or curling of the hair.

[0006] The hair styling apparatus may include a pump which is in fluid communication with the cartridge, and adapted to direct the fluid treatment agent from the cartridge and through

the heater element. The pump may be a pneumatic pump mounted to the second body of the second handle member, and positioned to engage the first body of the first handle member upon relative movement of the second handle member to the closed position to direct fluid, e.g. air, into the cartridge to cause release of the hair treatment agent under pressure from the cartridge.

[0007] In some embodiments, the cartridge includes a pump inlet conduit and a treatment agent outlet conduit. The pump inlet conduit and the treatment agent outlet conduit are in fluid communication with the pump and the heater element respectively upon mounting of the cartridge to the second body of the second handle member. The second body of the second handle member may define an agent port and a pump port for respectively receiving the agent outlet conduit and the pump inlet conduit of the cartridge.

[0008] In accordance with one embodiment, a hair styling apparatus includes a first handle member having a first body defining an internal chamber dimensioned to receive a length of hair and a second handle member having a second body. The second handle member is adapted for movement relative to the first handle member between an open position and a closed position. An elongate member is positioned within the internal chamber of the first body of the first handle member. A rotatable component is mounted to the first body and adapted for rotatable movement to engage the length of hair adjacent or within the internal chamber and wrap a segment of the hair about the elongate member. A cartridge is releasably mountable to the second handle member, and contains a hair treatment agent. A heater is in fluid communication with the cartridge for at least partially heating the treatment agent dispensed from the cartridge. At least one port is in fluid communication with the heater and positioned to

direct the heated treatment agent from the heater onto the hair disposed adjacent or within the internal chamber of the first handle member.

[0009] The hair styling apparatus may include a pneumatic pump which is mounted to the second body of the second handle member and in fluid communication with the cartridge. The pneumatic pump is engageable with the first body member upon relative movement of the second handle member toward the closed position to direct the treatment agent under pressure from the cartridge. The treatment agent may include water which converts to steam when subjected to heat of the heater for application to hair and enhance styling effects thereof.

[0010] Other details and advantages of the hair styling appliance are discussed will be appreciated from the following written description.

BRIEF DESCRIPTION OF THE DRAWINGS

[0011] Embodiments of the present disclosure will be readily appreciated by reference to the drawings wherein:

[0012] FIGS. 1A-1C are top, side and bottom plan views of the hair styling apparatus in accordance with the principles of the present disclosure illustrating the first and second handles and the cartridge mounted to the first handle;

[0013] FIGS. 1D-1E are front and rear axial views of the hair styling apparatus;

[0014] FIGS. 2-3 are perspective views of the hair styling apparatus;

[0015] FIG. 4 is a perspective view of the hair styling apparatus in partial cross-section illustrating the rotatable hair engaging component;

- [0016] FIG. 5 is an exploded perspective view of the hair styling apparatus;
- [0017] FIG. 6 is a perspective view of the hair styling apparatus illustrating the second handle separated from the first handle;
- [0018] FIGS. 7-9 are perspective views of the heat or vapor generating mechanism of the hair styling apparatus;
- [0019] FIG. 10 is a perspective view of the hair styling apparatus with the cartridge illustrated removed from the first handle; and
- [0020] FIG. 11 is a perspective view of the cartridge.

DETAILED DESCRIPTION

[0021] Referring initially to FIGS. 1A-1E, in conjunction with FIGS. 2-3, the hair styling apparatus 1 in accordance with the principles of the present disclosure is illustrated. The hair styling apparatus 1 is particularly adapted to apply a curling effect or treatment on the hair of a subject and incorporates a mechanism or system to apply a treatment agent to hair to enhance a styling effect. The mechanism may include one or more heating elements to heat the treatment agent prior to, or during, its application. The treatment agent may be water, which upon heating via the heating element, at least partially, e.g., fully, converts to steam to facilitate the hair curling process. Other treatment agents are also contemplated and are listed hereinbelow.

[0022] The apparatus 1 includes a handle section 2 having a first handle member or upper handle 3 and a second handle member or lower handle 4 connected to each other at respective ends, e.g., proximal ends, by a hinge section 5 in pivotal relation. The upper and lower handles 3, 4 are spring biased to an open position, shown in FIGS. 2 and 3, and are

adapted to pivot toward each other to a closed position shown in FIGS. 1A – 1E. An electrical power cord 6 has a conventional plug (not shown) at one end to engage a power source such as a wall outlet to provide electrical energy to operate the appliance. In the alternative, or optionally, the apparatus 1 may be battery operated. The battery may be rechargeable.

[0023] With particular reference to FIGS. 2-3, the apparatus 1 includes a head section 7 located at the distal end of the handle section 2, and having an upper head or first body 8 attached to the upper handle 3 and a lower head or second body 9 attached to the lower handle 4. The lower head 9 includes a round, side opening 10 and a slot-shaped top opening 11 dimensioned to receive a swatch of hair to be positioned into an interior chamber 12 defined by the lower head 9. The side opening 10 may permit the swatch of hair to protrude and move out of the interior chamber 12 of the lower head 9 during operation.

[0024] As best depicted in FIGS. 4-5, a rotatably-mounted, hair-engaging component 13 (e.g., rotatable component) is mounted within the lower head 9 and is adapted to selectively rotate, thereby causing the swatch of hair “h” positioned in the interior chamber 12 of the lower head 9 to be wound about a stationary, internal post 14 that is also located inside of the interior of the lower head 9. In one embodiment, a cylinder 15 is mounted within the lower head 9 and coaxially arranged about the internal post 14 to define the chamber 12. The cylinder 15 may define a slot 16 positioned in alignment with the top opening 11 so that a swatch of hair may be urged through both the slot 16 of the cylinder 15 and the top opening 11 of the lower head 9 by the rotatable component 14.

[0025] The rotatable component 13 has a leading edge 17 which engages and captures the hair “h” during its rotation about axis “k” (FIG. 4). The leading edge 17 may be arcuate, and is adapted to pull the hair “h” through the top opening 11 and the slot 16 of the cylinder 15 and wrap the hair “h” about the internal post 14 as described in the ‘118, ‘374 and ‘808 patents. An abutment 9b (FIG. 1B) may be positioned within the lower head 9. The abutment 9b engages the hair “h” during rotation of the rotatable component 13 such that the hair “h” is wound about the internal post 14 between the rotatable component 13 and the abutment 9b. The abutment 9b may be movable to permit removal of the wound hair subsequent to treatment.

[0026] With reference to FIG. 5, the rotatable component 13 may be mounted for rotational movement within the lower head 9 via conventional means inclusive of, e.g., with various gaskets, bearings, and gears appreciated by one skilled in the art and driven by motor 18. The motor 18 is operatively coupled to the rotatable component 13 through conventional means, and, may provide selective continuous, incremental, and/or reverse movement to the rotatable component 13. In embodiments, one of or both of the cylinder 15 and the internal post 14 can be heated by one or more electrical heat-generating components (e.g. heater 19) to impart heat to the swatch of hair “h” being styled in order to facilitate curling or styling of the hair.

[0027] With reference now to FIGS. 2-3 and 5, the apparatus 1 may have one or more control buttons, switches and/or timer lights or displays, generally referred to herein as control button and panel display 20. The panel display 20 may include a power indicator “on” light 21, push switch 22, time control switch 23 and motor control switch 24. The apparatus 1 may be provided with a switch or contact that is engaged by the action of closing the upper head 8

against the lower head 9, to activate the rotatable component 13 or the treatment agent heating system discussed hereinbelow.

[0028] The apparatus 1 may include a control circuit e.g., in the form of a circuit board, processor or other logic 25 (FIG. 5) that allows selective, or automatic, modes of operation that include a timer and time-out indicator e.g., audio or visual that is activated after operation for a predetermined time interval. Similarly, the control circuit may enable automatic shutoff after a predetermined amount of time or a predetermined number of rotation cycles of the rotatable component 14. The control circuit may provide a means to selectively or automatically control the direction of rotation, the speed, or both, of the rotatable component 14. The control circuit may enable a sensor that senses changes in rotational speed or torque and, in response to predetermined thresholds related thereto, shuts down, slows, and/or reverses direction or rotation of the rotatable component 14. Such a feedback may be used, for example, to prevent tangling or damaging of hair. The apparatus 1 may be provided with a control means that allows a user to selectively activate or de-activate the heating or vaporizing feature so that it may or may not be used during operation of the apparatus 1. This may be achieved, e.g., by a button, or manually controlled mechanism that is associated with a valve that blocks delivery of the treatment agent from the cartridge to the heater 19.

[0029] With reference to FIGS. 6-9, in conjunction with FIG. 5, in accordance with the present disclosure, the apparatus 1 may include a system or mechanism for dispensing a treatment agent onto the hair "h". The mechanism may be a heat generating and/or emitting system 26 for generating and directing a stream of treatment agent, e.g., heated treatment agent,

onto the hair “h”. In an embodiment, the system 26 is adapted to at least partially vaporize the treatment agent to apply heated vaporized agent to the hair. The treatment agent may include water which is heated to create steam for application to the hair “h”. Other treatment agents with or without water are also contemplated.

[0030] The system 26 includes a cartridge 27 which, in one embodiment, is releasably mounted to the upper handle 3, specifically, the upper head 8 of the upper handle 3. The system 26 further includes a heating element 28, and a pneumatic pump 29. The heating element 28 is in fluid communication with the cartridge 27 through conduit 30 and the pneumatic pump 29 is in fluid communication with the cartridge 27 through conduit 31. The heating element 28 includes a plurality of outlet ports 32 (see also FIG. 3) which directs the treatment agent (e.g., partially vaporized) onto the swatch of hair “h” within or adjacent to the chamber 12. The heating element 28 may be any type of resistive heater or may be an ultrasound transducer which oscillates to generate mechanical energy transformable into heat. Other heating elements 28 are also envisioned.

[0031] Generally, in operation, a swatch of hair is positioned between the open upper and lower heads 8, 9 of the handle 3, 4 adjacent the slot 12. The handles 3,4 are moved to the closed position of FIGS. 1A-1E, which causes the pneumatic pump 29 to be engaged by an opposing face 8a of the upper head 8. This action compresses the pump 29 which forces air through conduit 31 and into cartridge 27, to thereby expel the treatment agent from the cartridge 27 and into the conduit 30 for distribution within the heater element 28. The apparatus 1 is activated and the hair is engaged by the rotational component 14. During, subsequent, or at anytime

during use of the apparatus 1, the heat/vapor generating system 26 is activated to cause the heater element 28 to heat and/or at least partially vaporize the treatment agent for application of the heated treatment agent to the hair “h”. The heating element 19 may be activated, either manually or automatically. The agent, thus, is directed into the heating element 28 where it is heated, e.g., to the point of producing steam (e.g., when water is a component of the treatment agent) and emitted from the emission port or holes 32. In embodiments, the ports 32 direct steam through slot 16 and opening 11 into internal chamber 12 where it communicates with the hair positioned about or adjacent post 14.

[0032] The apparatus 1 may be provided with a control means that permits a user to selectively activate or de-activate the heating or vaporizing feature so that it may or may not be used during operation of the apparatus 1. This, may be achieved, for example, by a button or manually controlled mechanism (e.g., optionally inclusive of any of the controls discussed hereinabove in connection with the control panel display 20) that is associated with a valve that blocks delivery of water from the cartridge to the heating element 28.

[0033] With reference to FIGS. 10-11, in one embodiment, the cartridge 27 is removable from the apparatus 1 so that a user may remove the cartridge 27 and refill it with a treatment agent such as water or other agent. More specifically, the cartridge 27 is slidably received in a recess 33 defined in the upper head 8 of the upper handle 3. The recess 33 may be defined by a pair of overhangs 34 which engage a pair of corresponding slots 35 defined in the housing 27a of the cartridge 27 to retain the cartridge 27 within the recess 33. Other arrangements for releasably mounting the cartridge 27 within the upper head 8 of the upper handle 3 are also envisioned. The

cartridge housing 27a may optionally include a filling plug 36 through which the treatment agent is introduced into the cartridge 27. The filling plug 36 may include a rubber plug or gasket which is selectively movable between open and closed positions relative to the cartridge housing 27a. The cartridge housing 27a further includes an air inlet conduit 37 and an agent outlet conduit 38. The air inlet conduit 37 and the agent outlet conduit 38 are respectively received within a corresponding air port 39 and a fluid port 40 within the upper head 8 of the upper handle 3 when the cartridge 27 is mounted to the upper handle 3. The air port 39 and the fluid port 40 are in fluid communication with conduits 31, 30 respectively leading to the pneumatic pump 29 and the heater element 28.

[0034] Other treatment agents for filling within cartridge 27 are also envisioned. For example, one alternate treatment agent may be Argan oil extracted from the fruits of the argan tree, *argania spinosa*, that is endemic to Morocco. The hair care composition may solely contain argan oil, or may include argan oil in combination with other ingredients. Examples of other ingredients include pharmaceutically active agents, moisturizers, hydration agents, penetration agents, preservatives, conditioners, emulsifiers, natural or synthetic oils, solvents, surfactants, detergents, gelling agents, emollients, antioxidants, fragrances, fillers, thickeners, waxes, odor absorbers, dyestuffs, coloring agents, powders, viscosity-controlling agents, buffers, protectants, pH regulators, chelating agents, humectants, conditioners, glitter, mica, minerals, silicones, polyphenols, sunblocks, phytomedicinals, and combinations thereof, as well as other additives typically used in hair care products as appreciated by those skilled in the art. The treatment agent may be heated by the system, with or without effecting at least partial vaporization of the agent for application to hair.

[0035] Persons skilled in the art will understand that the devices and methods specifically described herein and illustrated in the accompanying drawings are non-limiting exemplary embodiments. It is envisioned that the elements and features illustrated or described in connection with one exemplary embodiment may be combined with the elements and features of another without departing from the scope of the present disclosure. As well, one skilled in the art will appreciate further features and advantages of the disclosure based on the above-described embodiments. Accordingly, the disclosure is not to be limited by what has been particularly shown and described.

WHAT IS CLAIMED IS:

1. A hair styling apparatus, which comprises:
 - a first handle member including a first body defining an internal chamber dimensioned to receive a length of hair;
 - a second handle member including a second body, the second handle member adapted for adapted for movement relative to the first handle member between an open position and a closed position;
 - an elongate member positioned within the internal chamber of the first body of the first handle member;
 - a rotatable component mounted to the first body and adapted for rotatable movement to engage the length of hair within the internal chamber and wrap a segment of the hair about the elongate member; and
 - a cartridge mountable to one of the first and second handle members, the cartridge including a hair treatment agent for dispensing and treating hair disposed adjacent or within the internal chamber of the first handle member.
2. The hair styling apparatus according to claim 1 including a heater for heating the hair treatment agent.
3. The hair styling apparatus according to claim 2 wherein the cartridge is releasably mountable to the second body of the second handle member.

4. The hair styling apparatus according to claim 3 wherein the second body includes the heating element.

5. The hair styling apparatus according to claim 4 wherein the heating element is dimensioned to at least partially vaporize the hair treatment agent.

6. The hair styling apparatus according to claim 5 wherein the hair treatment agent is water which converts to steam when subjected to the heating element.

7. The hair styling apparatus according to claim 4 including a pump in fluid communication with the cartridge, the pump adapted to direct the fluid treatment agent from the cartridge and through the heater element.

8. The hair styling apparatus according to claim 7 wherein the pump is a pneumatic pump mounted to the second handle member, the pneumatic pump being engageable with the first body member upon relative movement of the second handle member to the closed position.

9. The hair styling apparatus according to claim 7 wherein the cartridge includes a pump inlet conduit and a treatment agent outlet conduit, the pump inlet conduit and the treatment agent outlet conduit in fluid communication with the pump and the heater element respectively upon mounting of the cartridge to the second body of the second handle member.

10. The hair styling apparatus according to claim 9 wherein the second body of the second handle member defines an agent port and a pump port for respectively receiving the agent outlet conduit and the pump conduit of the cartridge upon mounting of the cartridge to the second body of the second handle member.

11. A hair styling apparatus, which comprises:

a first handle member including a first body defining an internal chamber dimensioned to receive a length of hair;

a second handle member including a second body, the second handle member adapted for movement relative to the first handle member between an open position and a closed position;

an elongate member positioned within the internal chamber of the first body of the first handle member;

a rotatable component mounted to the first body and adapted for rotatable movement to engage the length of hair within the internal chamber and wrap a segment of the hair about the elongate member;

a cartridge releasably mountable to the second handle member, the cartridge including a hair treatment agent;

a heater in fluid communication with the cartridge for at least partially heating the treatment agent dispensed from the cartridge; and

at least one port in fluid communication with the heater and positioned to direct the treatment agent from the heater onto the hair disposed adjacent or within the internal chamber of the first handle member.

12. The hair styling apparatus according to claim 11 including a pneumatic pump mounted to the second handle member and in fluid communication with the cartridge, the pneumatic pump being engageable with the first body member upon relative movement of the second handle member toward the closed position to direct the treatment agent under pressure from the cartridge.

13. The hair styling apparatus according to claim 12 wherein the treatment agent includes water which converts to steam when subjected to the heater.

14. The hair styling apparatus according to claim 11 wherein the cartridge includes a pump inlet conduit and a treatment agent outlet conduit, the pump inlet conduit and the treatment agent outlet conduit in fluid communication with the pump and the heater element respectively upon mounting of the cartridge to the second body of the second handle member.

15. The hair styling apparatus according to claim 14 wherein the second body of the second handle member defines an agent port and a pump port for respectively receiving the agent outlet conduit and the pump conduit of the cartridge upon mounting of the cartridge to the second body of the second handle member.

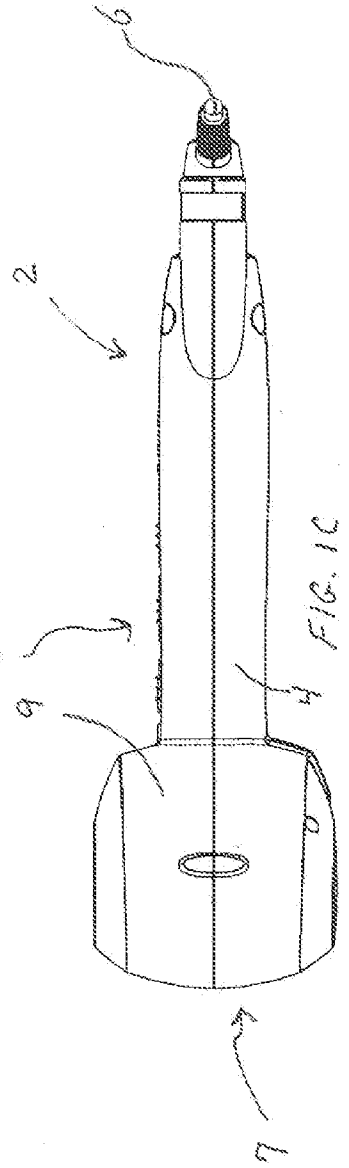
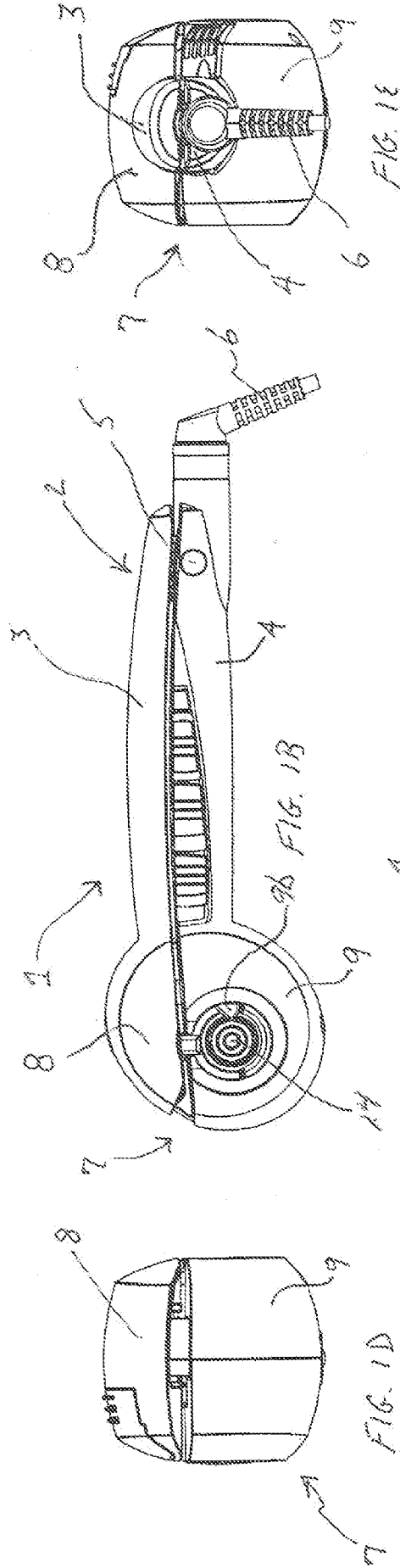
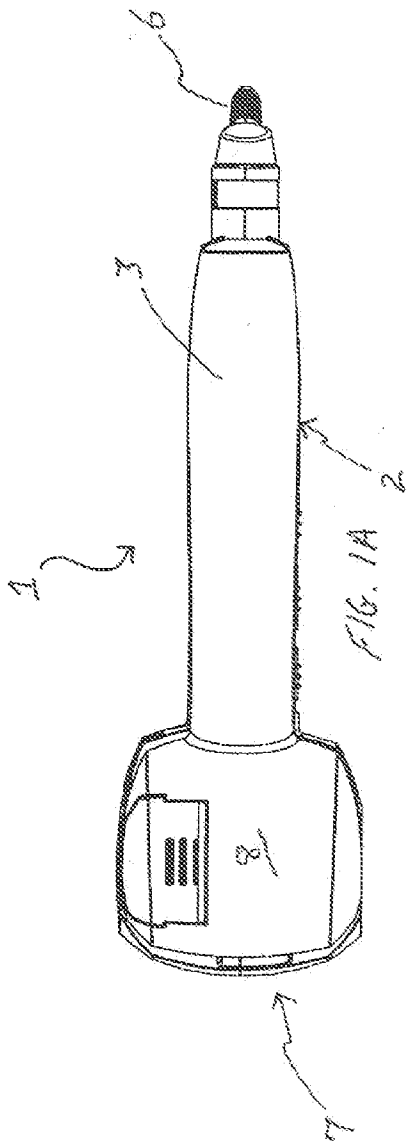

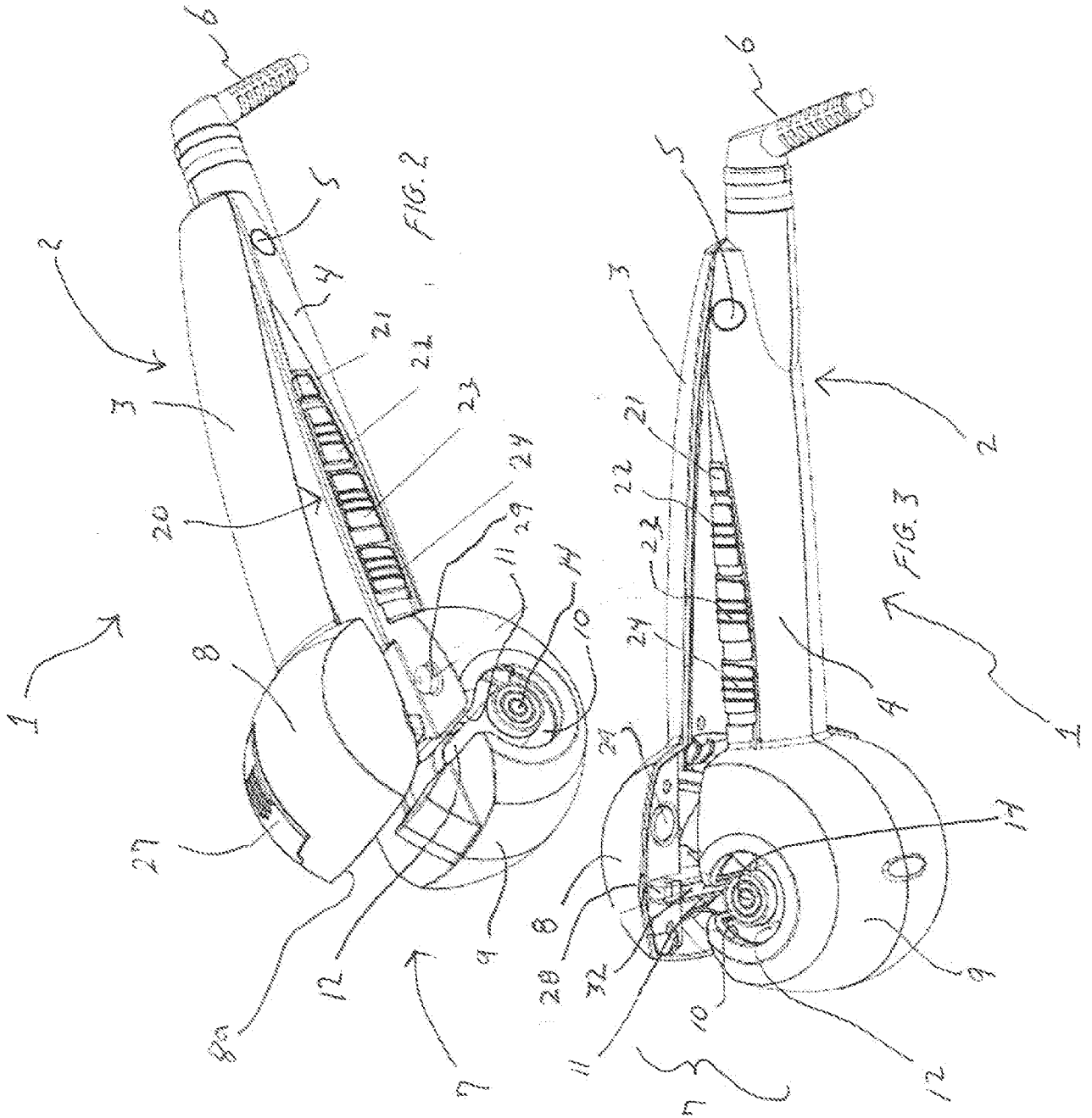

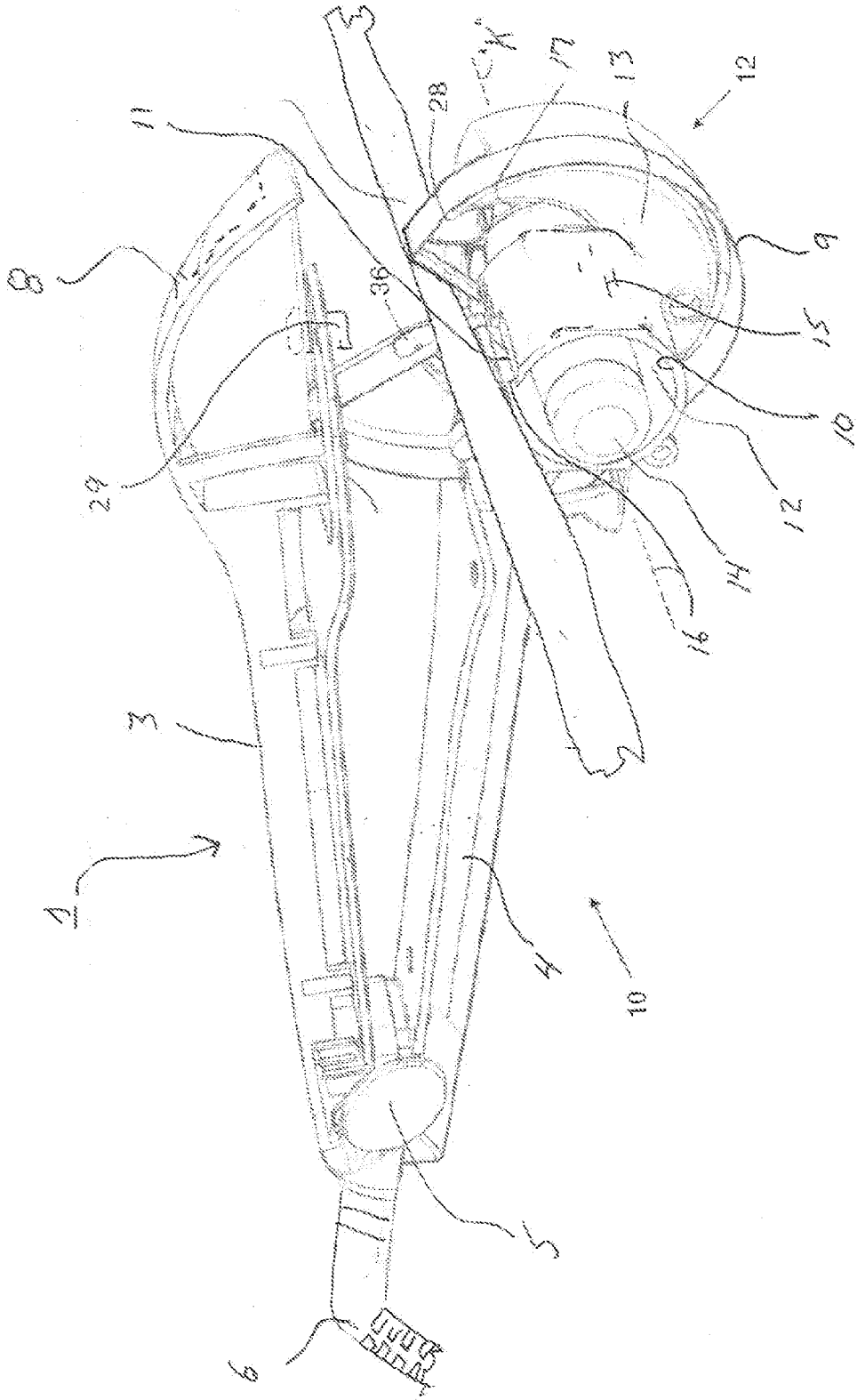

FIG. 4

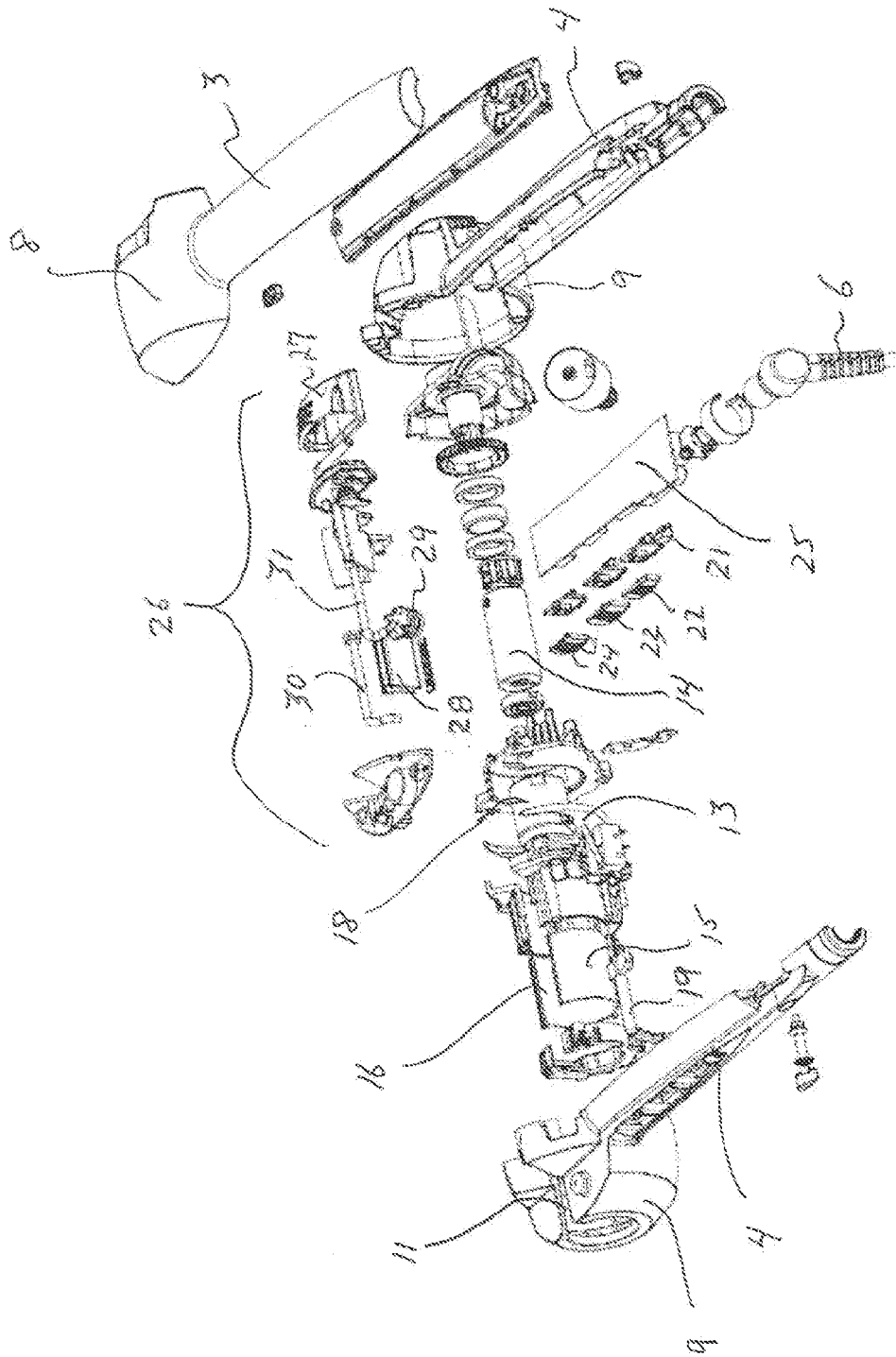

FIG. 5

