

B. MORSE.  
Horse Hay-Rakes.

No. 153,201.

Patented July 21, 1874.

*Fig. 1.*

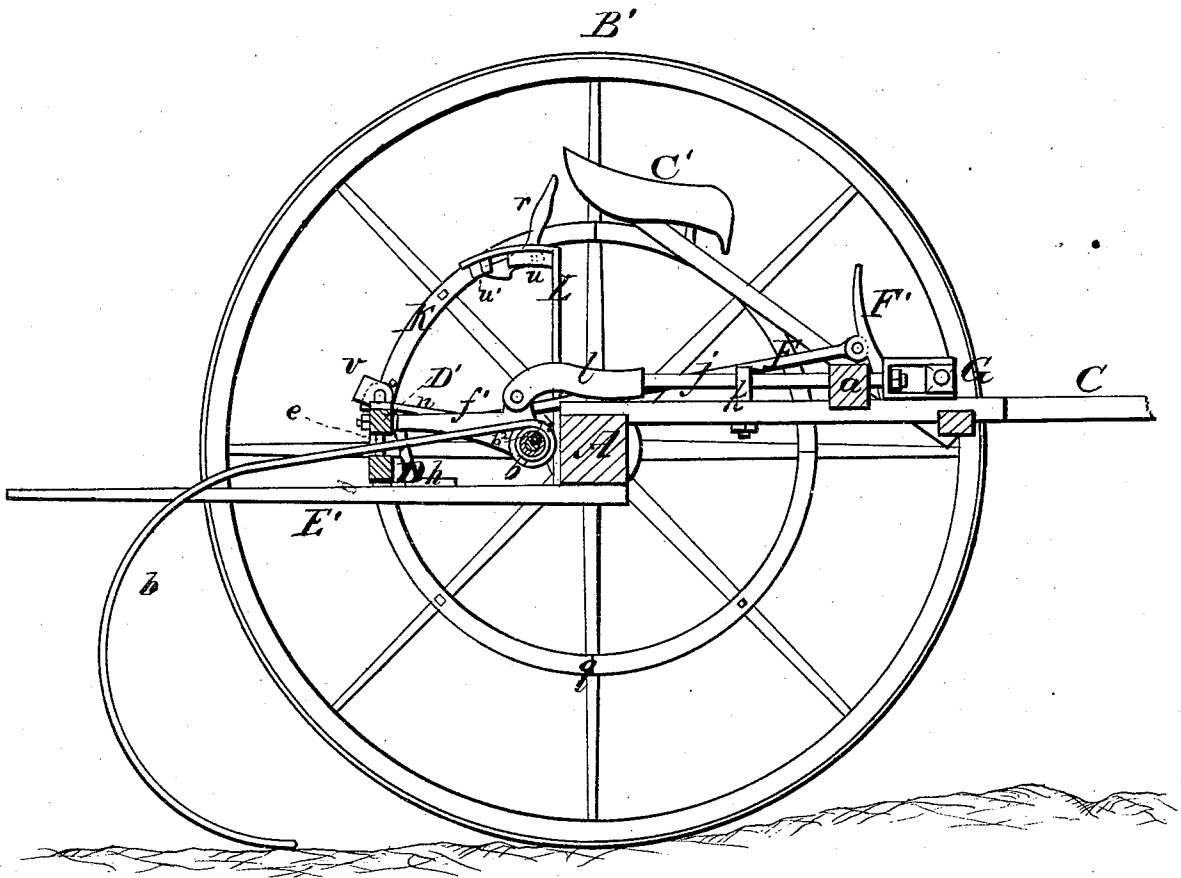

Witnesses.  
*E. H. Bates.*  
*George E. Upham.*

Inventor.  
*Ben Morse,*  
*Chipman & Fossum & Co.,*  
*attys.*

B. MORSE.  
Horse Hay-Rakes.

No. 153,201.

Patented July 21, 1874.

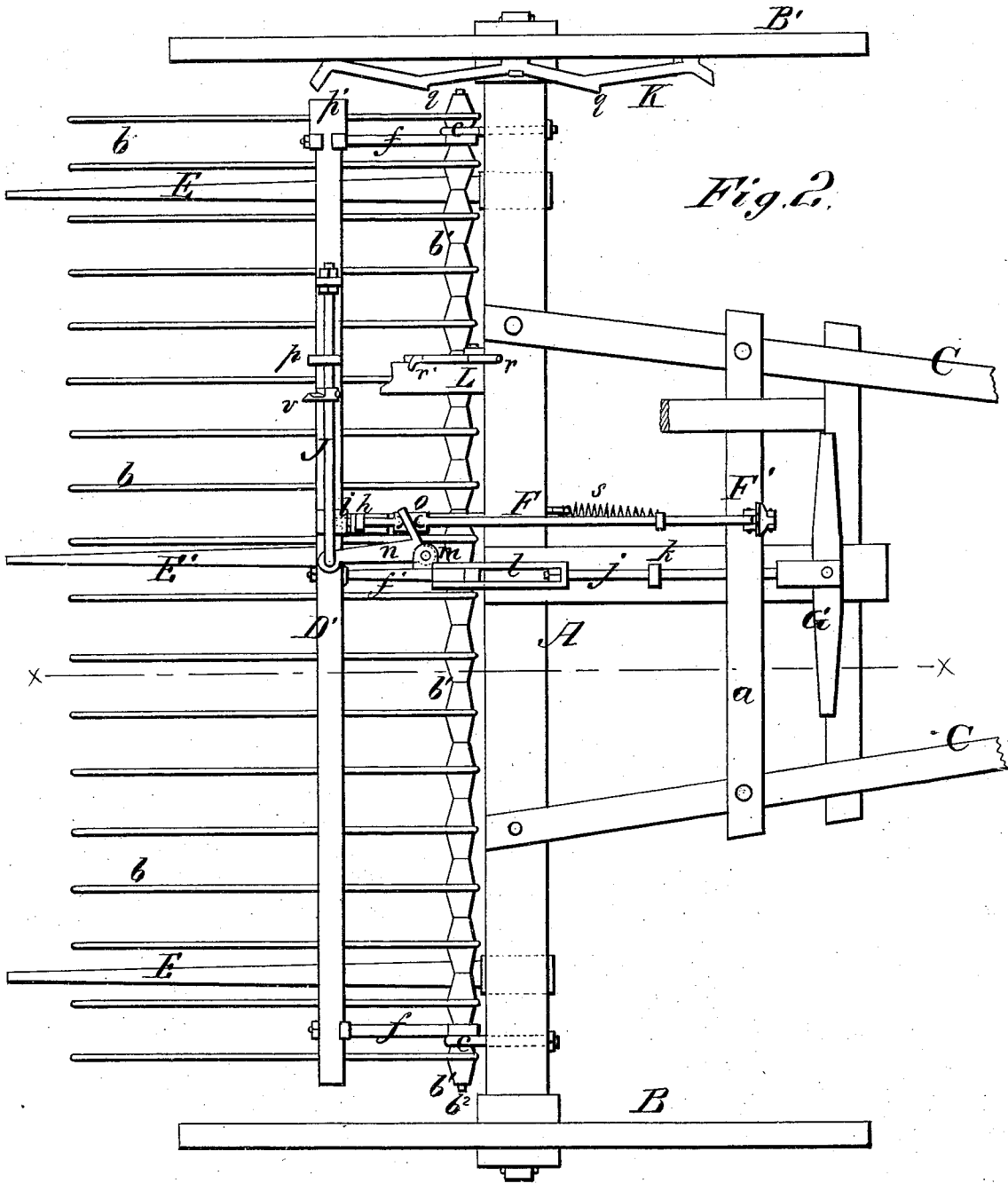

Witnesses.  
*E. H. Bates.*  
*George C. Upham.*

Inventor.  
*Ben Morse*  
*Chipman & Fosmire & Co.*  
*City*

B. MORSE.  
Horse Hay-Rakes.

No. 153,201.

Patented July 21, 1874.

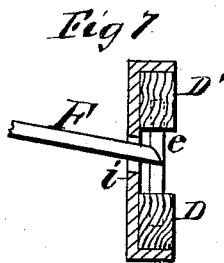
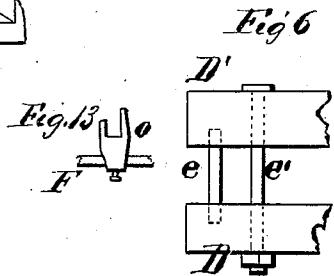
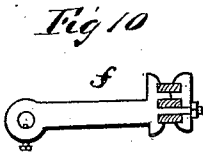
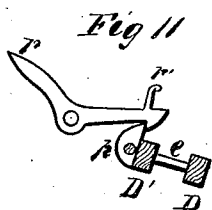
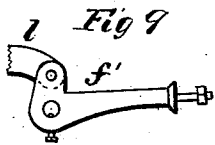
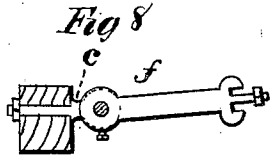
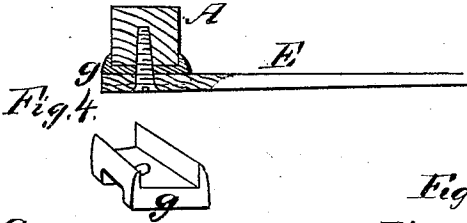
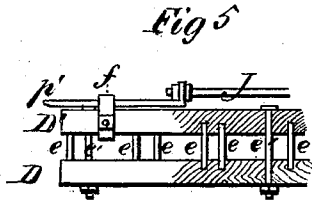
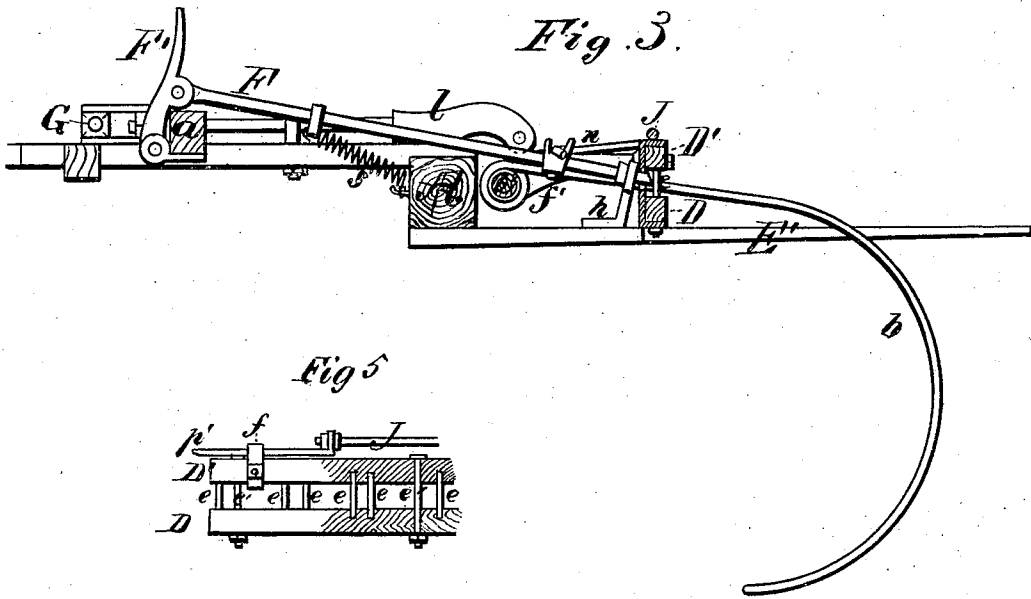

Witnesses.  
E. A. Bates  
George E. Upham

Inventor.  
Ben Morse,  
Chipman & Osmer & Co,  
Atty.

# UNITED STATES PATENT OFFICE.

BEN MORSE, OF ITHACA, NEW YORK.

## IMPROVEMENT IN HORSE HAY-RAKES.

Specification forming part of Letters Patent No. **153,201**, dated July 21, 1874; application filed January 24, 1874.

*To all whom it may concern:*

Be it known that I, BEN MORSE, of Ithaca, in the county of Tompkins and State of New York, have invented a new and valuable Improvement in Horse Hay-Rakes; and I do hereby declare that the following is a full, clear, and exact description of the construction and operation of the same, reference being had to the annexed drawings, making a part of this specification, and to the letters and figures of reference marked thereon.

Figure 1 of the drawings is a representation of a sectional view of my horse hay-rake. Fig. 2 is a plan view of the same. Figs. 3, 4, 5, 6, 7, 8, 9, 10, 11, 12, and 13 are detail views of the same.

This invention has relation to sulky hay-rakes, wherein the rake-teeth are raised for discharging the gathered loads by the draft or power of the team, and also wherein the rake-teeth are held down to their work by means of a catching device.

The following is a description of a rake embracing the improvements which I have made on the above-named class of rakes:

In the annexed drawings, A designates the axle of two transporting-wheels. B B' and C C are thills, which are rigidly secured on said axle, and to which is applied a cross-bar, *a*. C' is the driver's seat, which is mounted on an inclined bar rising from the cross-bar *a*, and arranged in close relation to the wheel B'. The rake-teeth *b* are secured to tubular bearings *b*<sup>1</sup> on a bar, *b*<sup>2</sup>, which is supported by eye-bearings *c c*, fixed to the rear side of the axle A. These teeth *b* pass between pins *e*, which are between two parallel bars, D D', into which bars the ends of the pins *e* are inserted and confined by tie-bolts *e'*. The lower bar, D, is designed for lifting the rake-teeth, and the upper bar, D', for holding these teeth down to their work. These pins and their bars will keep the rake-teeth in proper position, and are an improvement on staple-guides and a single bar. By means of arms *f f* and a lever, *f'*, the bars D D' are connected to the bar *b*<sup>2</sup>, on which the rake-teeth articulate. E E' E are strippers, which clear the hay from the rake-teeth as these teeth are raised. The two strippers E E are secured to the bottom of the axle A by means of metal clasps *g*, and one or more

screws. These clasps *g* are flanged, as shown in Fig. 4, and the flanges embrace the bottom of the axle and the ends of the strippers, so as to form rigid and substantial attachments therefor. That portion of the intermediate stripper E' which is between the axle A and bar D is made quite broad, and affords a support for a guide, *h*, through which a bolt, F, plays. This bolt F is intended for locking the bars D D' down when the teeth *b* are in raking position, and for this purpose its rear end enters a slot made through a plate, *i*, which is secured to the two bars D D'. The bolt F extends forward over the axle A, and is pivoted to a foot-lever, F', convenient to the driver when in his seat C', and by means of a spring, *s*, the said bolt is forced backward when the foot is removed from lever F'. G designates a single-tree, to which the animal is hitched, which single-tree is pivoted to a clasp on the front end of a draft-rod, *j*. Rod *j* passes loosely through the cross-bar *a*, and through a guide, *k*, and its rear end is attached to a link, *l*, which is pivoted to the shortest arm of the angular lever *f'*, as shown in Fig. 1. On one side of the lever *f'* are two fixed ears, *m*, between which an angular lever, *n*, is pivoted so as to vibrate horizontally. The shortest arm of lever *n* is received into the crotch of a fork, *o*, fixed on the bolt F, and the longest arm of this lever *n* has pivoted to it one end of a rod, J, which passes through a guide, *p*, on the bar D', and is adjustably secured to a lifting-slide, *p'*. This lifting-slide *p'* is held down upon the bar D' by means of fixed clasps, and its outer end is slightly beveled underneath. On the inner side of the transporting-wheel B' is a concentric series of lifting-tappets, *q*, which are formed at the angles of a zigzag lifting-ring, K. As before stated, the rake-teeth *b* are held down to their work by the bolt F entering a plate, *i*, affixed to the bars D D'.

When the driver desires to discharge a gathered load he presses the foot-lever F' forward and releases the bolt F from the bars D D', and by the same movement the slide *p'* is thrust out far enough to bring it in range of the tappets *q* on the lifting-ring K. One of the tappets *q* will then strike the outer end of slide *p'* and throw up the rake-teeth *b* until a

hooked hand-lever, *r*, catches on the bottom of the guide *p*. At the same time that the hook on lever *r* catches under the guide *p* a beveled flange, *u*, on the under side of the curved overhanging portion of a bracket, *L*, which is fixed to the axle *A*, will strike a double-beveled lug, *v*, which is adjustably secured on the rod *J*, and move back the slide *p'* out of the range of the tappets *g*. The rake will now remain in an elevated position, it being so held by the hooked lever *r*, which is pivoted on one side of the bracket *L*. I will here state that the lever *r* is held in a position for engaging with guide *p* by means of an offset, *r'*, formed on this lever, which rests on the overhanging portion of the bracket *L*. When the lever *r* is released from the guide *p* the rake will fall back to a working position, and in doing so the lug *v* will be struck by another beveled flange, *u'*, on bracket *L*, which will give the slide *p'* another inward movement and adjust the lever *n*, so that its short arm will fall into the crotch of the fork *o* on bolt *F*, which latter will spring into the slot in plate *i* and hold down the rake.

What I claim as new, and desire to secure by Letters Patent, is—

1. The sliding bolt *F*, having a foot-lever, *F'*,

on one end, in combination with the spring *s*, guide *h*, and an engaging-plate, *i*, on bars *D* *D'*, substantially as and for the purposes described.

2. The fork *o* on bolt *F*, in combination with lever *n*, pivoted to lever *f'*, and with the slide *p'* and lifting-tappets *g*, substantially as and for the purpose described.

3. The beveled lug *v* on the rod *J*, and slide *p'*, in combination with the beveled flanges *u u'* on the bracket *L*, substantially as described.

4. The combination of the angular lever *n*, fork *o*, lug *v*, and flange *u* with lever *r*, rod *J*, slide *p'*, and lifting-tappets *g*, substantially as described.

5. The single-tree *G*, connected to lever *f'* by means of link *l* and rod *j*, in combination with the locking-down and releasing bolt *F*, actuated as described.

In testimony that I claim the above I have hereunto subscribed my name in the presence of two witnesses.

BEN MORSE.

Witnesses:

ABEL BURRITT,

I. C. MCWHORTER.