

(No Model.)

J. HACKER, L. W. COLBY & J. W. HELTON.
WATER HEATER.

No. 421,274.

Patented Feb. 11, 1890.

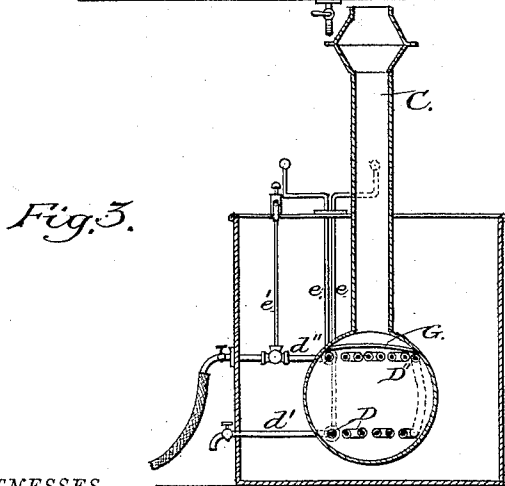
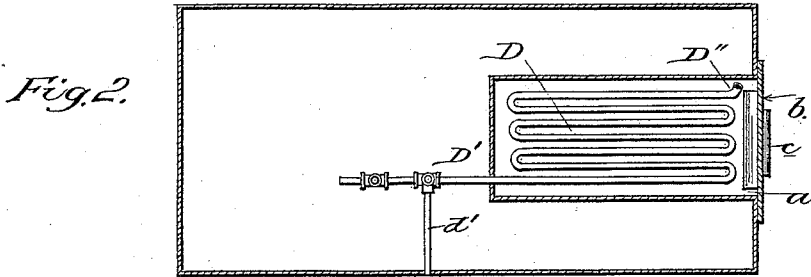
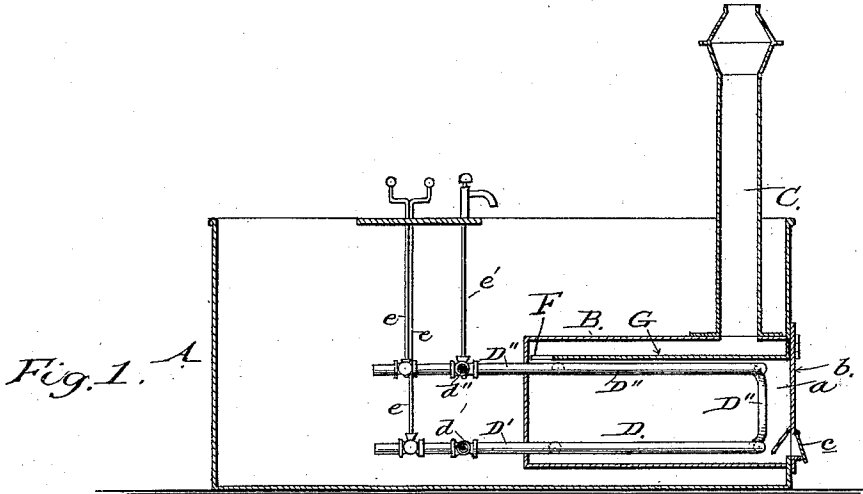

WITNESSES
N. H. Fowler,
N. H. Patterson

INVENTORS
Joseph Hacker,
Lucius W. Colby,
John W. Helton.
by *A. H. Evans & Co*
Attorneys

UNITED STATES PATENT OFFICE.

JOSEPH HACKER, LUCIUS W. COLBY, AND JOHN W. HELTON, OF WATERLOO,
IOWA.

WATER-HEATER.

SPECIFICATION forming part of Letters Patent No. 421,274, dated February 11, 1890.

Application filed August 29, 1889. Serial No. 322,318. (No model.)

To all whom it may concern:

Be it known that we, JOSEPH HACKER, LUCIUS W. COLBY, and JOHN W. HELTON, citizens of the United States, residing at Waterloo, in the county of Black Hawk and State of Iowa, have invented certain new and useful Improvements in Water-Heaters, of which the following is a full and clear description, reference being had to the accompanying drawings, forming part of this specification, in which—

Figure 1 represents a vertical longitudinal sectional view of a heater embodying our invention. Fig. 2 is a horizontal sectional view of the same, showing lower coil. Fig. 3 is a cross-sectional view of the boiler, showing the internal coils of pipe and flue-plate.

Our invention relates to that class of heaters which is designed to supply warm water for bathing, stock, and other purposes. It is an improvement on our patent, No. 406,727, dated July 9, 1889, for a similar invention; and it consists in the construction and combination of devices, which we shall hereinafter fully describe and claim.

To enable others skilled in the art to make and use our invention, we will now describe its construction and indicate the manner in which we carry the same out.

In the accompanying drawings, A represents a tank, of any suitable form, construction, and dimensions, adapted to contain water, which may be used for domestic or stock purposes; and B is a longitudinally-disposed furnace or receptacle supported in the tank near its bottom and extending from one end thereof toward the center, the said tank being formed with an opening *a* leading to the furnace or receptacle and permitting the insertion or removal of any well-known form of heating medium.

If desired, a fire may be built within the furnace or receptacle to supply the necessary heat. The open end of the furnace is covered or closed by a hinged door *b*, secured to the tank, and said door is provided with a valve or damper *c* for regulating the supply of air to the heating device or medium. The furnace or receptacle B communicates at its top with a flue C, which carries off the products of combustion from the heating device. As thus far

described our present invention is identical with patent before referred to. Within the lower portion of the furnace or receptacle B is a coil of pipe D, which is horizontally placed, to serve also the purposes of a grate, and having two ends or arms, one of which D' opens into the body of water in the tank and is designed to conduct the cold water therein to the coil, whereby it is heated, while the other end or arm D'' is bent upward and formed into another horizontal coil in the upper portion of the furnace, and then it opens out through the back wall of the furnace into the body of water in the tank. Each end or arm of the pipe is provided with branches *d'* and *d''*, leading outside of the tank, and each branch is in turn supplied with stop-cocks to regulate the flow of water or steam for any desired purpose. At each end of the arms D' and D'' we place the ordinary valves, which are opened or closed by means of the rods *e e*.

To guard against possible accidents from bursting in case fire be started when the valves are all closed, we provide a safety-valve *e'*.

The upper coil of the pipe D does not extend entirely back to the rear wall of the furnace; but an opening F is left for the passage of the products of combustion. Above this upper coil and between that and the top arch of the furnace we place a closely-fitting sliding plate or flue strip G, with an opening at its rear end for the passage of the smoke and other products of combustion. It is evident from this description that these products would have to pass first to the rear of the furnace, and after rising above the plate G would return to the forward part of the furnace to find an outlet through the smoke-stack C. The effect of this circuitous passage of the heat and the products of combustion would be a great economy of fuel and a more rapid heating of the water.

Having thus described our invention, what we claim as new, and desire to secure by Letters Patent, is—

1. The combination, with the tank and the furnace provided with the flue C, of two coils, one in the upper and one in the lower part of the furnace, said coils being connected together and each having one end communicat-

ing with the tank, and the flue-plate placed above the upper coil and having a passage for the escape of the products of combustion to the flue, substantially as described.

5 2. The tank, the furnace therein having the flue C, in combination with two connected coils, one in the upper and one in the lower part of the furnace, the latter serving as a grate-bar, said coils having each an end com-
10 municating with the tank, valves in said ends

and rods by which said valves are operated, and branch pipe *d'* and *d''* leading from the arms to the exterior of the tank, substantially as herein described.

JOSEPH HACKER.
LUCIUS W. COLBY.
JOHN W. HELTON.

Witnesses:

T. S. WAND,
J. M. WALKER.