

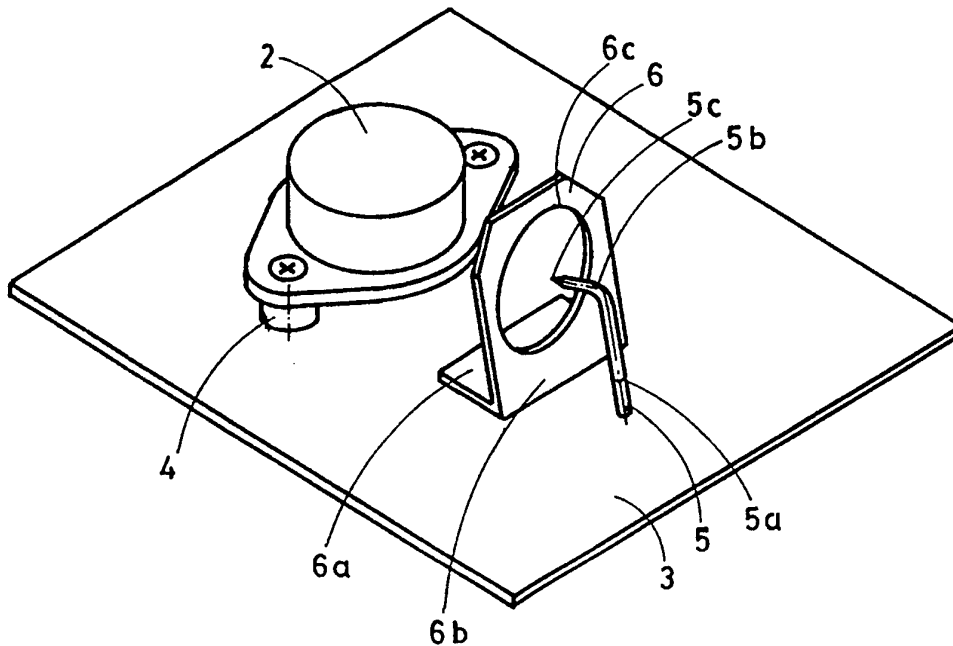

INTERNATIONAL APPLICATION PUBLISHED UNDER THE PATENT COOPERATION TREATY (PCT)

<p>(51) International Patent Classification⁵ : B03C 3/00</p>	<p>A1</p>	<p>(11) International Publication Number: WO 94/12282 (43) International Publication Date: 9 June 1994 (09.06.94)</p>
<p>(21) International Application Number: PCT/US93/11378 (22) International Filing Date: 23 November 1993 (23.11.93) (30) Priority Data: 103867 25 November 1992 (25.11.92) IL (71) Applicants (for all designated States except US): SPECTREX INC. [US/US]; Peckman Industrial Park, 220 Little Falls Road, Cedar Grove, NJ 07009 (US). SPECTRONIX LTD. [IL/IL]; P.O. Box 29, 80 150 Sderot (IL). (72) Inventors; and (75) Inventors/Applicants (for US only): SPECTOR, Yechiel [IL/IL]; 5 Avner Street, Zahala, 69 937 Tel Aviv (IL). SHER, Eran [IL/IL]; 26 Hameshahrerim Street, 84 299 Beersheba (IL). SERERO, Shaul [IL/IL]; 24 Hapazit Street, Rishon Lezion (IL). (74) Agent: BARISH, Benjamin, J.; c/o Sheinbein, Robert, 2940 Birchtree Lane, Silver Spring, MD 20906 (US).</p>	<p>(81) Designated States: AT, AU, BB, BG, BR, BY, CA, CH, CZ, DE, DK, ES, FI, GB, HU, JP, KP, KR, KZ, LK, LU, MG, MN, MW, NL, NO, NZ, PL, PT, RO, RU, SD, SE, SK, UA, US, VN, European patent (AT, BE, CH, DE, DK, ES, FR, GB, GR, IE, IT, LU, MC, NL, PT, SE), OAPI patent (BF, BJ, CF, CG, CI, CM, GA, GN, ML, MR, NE, SN, TD, TG).</p> <p>Published With international search report.</p>	

(54) Title: COOLING METHOD AND APPARATUS



(57) Abstract

A method for cooling a heat-generating body (2), particularly for cooling electrical devices, such as power supplies, and the like. The method comprises generating an ion wind by corona discharge, and directing the ion wind toward the heat-generating body (2), to dissipate substantial quantities of heat therefrom by convection. An apparatus (5, 6), comprising an electrode assembly (5c, 6c), for use in the method is also described.

FOR THE PURPOSES OF INFORMATION ONLY

Codes used to identify States party to the PCT on the front pages of pamphlets publishing international applications under the PCT.

AT	Austria	GB	United Kingdom	MR	Mauritania
AU	Australia	GE	Georgia	MW	Malawi
BB	Barbados	GN	Guinea	NE	Niger
BE	Belgium	GR	Greece	NL	Netherlands
BF	Burkina Faso	HU	Hungary	NO	Norway
BG	Bulgaria	IE	Ireland	NZ	New Zealand
BJ	Benin	IT	Italy	PL	Poland
BR	Brazil	JP	Japan	PT	Portugal
BY	Belarus	KE	Kenya	RO	Romania
CA	Canada	KG	Kyrgystan	RU	Russian Federation
CF	Central African Republic	KP	Democratic People's Republic of Korea	SD	Sudan
CG	Congo	KR	Republic of Korea	SE	Sweden
CH	Switzerland	KZ	Kazakhstan	SI	Slovenia
CI	Côte d'Ivoire	LI	Liechtenstein	SK	Slovakia
CM	Cameroon	LU	Luxembourg	SN	Senegal
CN	China	LV	Latvia	TD	Chad
CS	Czechoslovakia	MC	Monaco	TG	Togo
CZ	Czech Republic	MD	Republic of Moldova	TJ	Tajikistan
DE	Germany	MG	Madagascar	TT	Trinidad and Tobago
DK	Denmark	MN	Mongolia	UA	Ukraine
ES	Spain			US	United States of America
FI	Finland			UZ	Uzbekistan
FR	France			VN	Viet Nam
GA	Gabon				

COOLING METHOD AND APPARATUS

The present invention relates to a method, and also to apparatus for cooling a heat-generating body. The invention is especially useful for cooling electrical devices, such as power transistors, hybrid electronic devices, electrical power supplies, and the like, and is therefore described below with respect to such application, but it will be appreciated that the invention could advantageously be used in other applications as well.

When a strong electrical field is applied in a gap between a sharply curved electrode surface serving as an anode, and another electrode surface of less curvature, (e.g., planar) serving as a cathode, the gas near the anode breaks down at a voltage less than the spark-breakdown voltage for that gap length. This local breakdown is in the form of a glow discharge, which at atmospheric pressure is usually called corona. Positive ions are formed at the anode and are accelerated towards the cathode. Collisions between these ions and neutral gas molecules transfer momentum to the bulk gas, resulting in a directional body force, called an ion wind. Under normal conditions, this kind of electro-fluid-dynamics (EPD) device can produce wind velocities up to 8-12 meters per second. These air displacements can be highly localized according to the specific electrode configuration.

Our Israel Patent Applications 92951, 94367 and 95543 (corresponding to US Patent No.5,090,482) disclose the use of such an ion wind for extinguishing a fire.

The present application is directed to the use of such an ion wind for cooling a heat-generating body.

According to one aspect of the present invention, there is provided a method of cooling a heat-generating body comprising: generating an ion wind by corona discharge; and directing the ion wind towards the heat-generating body to dissipate substantial quantities of heat therefrom by convection.

According to one described embodiment, the corona discharge is produced between a pointed anode and a cathode.

According to a second preferred embodiment of the invention described below, the corona discharge is produced between a wire anode and a cathode of an electrode assembly. In this described embodiment, the cathode includes a planar section formed with a longitudinally-extending rectangular slot having two wing sections extending along the opposite longitudinal edges of the slot, the wing sections being angled towards, but terminating short of, each other; the wire anode being located midway between the wing sections such that the wing sections direct the ion wind towards the heat-generating body.

A further embodiment is described, wherein there are a plurality of the electrode assemblies extending along

one orthogonal axis and spaced from each other along a second orthogonal axis to generate an ion wind along the third orthogonal axis.

The invention also provides apparatus for cooling a heat-generating body according to above method.

As will be described below, the invention could be used for cooling various types of heat-generating bodies, including power transistors or hybrid electronic devices mounted on a printed circuit board, an electronic power supplies, etc.

Further features and advantages of the invention will be apparent from the description below.

The invention is herein described, by way of example only, with reference to the accompanying drawings, wherein:

Fig. 1 illustrates one form of apparatus constructed in accordance with the present invention;

Fig. 2 is a side elevational view of the apparatus of Fig. 1;

Fig. 3 illustrates a second form of apparatus constructed in accordance with the present invention;

Fig. 4 is a side elevational view of a part of the apparatus of Fig. 3;

Fig. 5 illustrates a further form of apparatus constructed in accordance with the present invention;

Fig. 6 is a fragmentary view of a portion of the apparatus of Fig. 5 to better show internal structure;

and Fig. 7 illustrates a further form of apparatus constructed in accordance with the present invention.

Figs. 1 and 2 illustrate the invention as applied for cooling a power transistor 2 mounted on a printed circuit board 3 by a plurality of spacers 4. In this apparatus, the power transistor 2 is cooled by an ion wind generated by corona discharge produced between an anode electrode 5 and a cathode electrode 6 mounted adjacent to the power transistor 2. The anode electrode 5 includes a first leg 5a fixed to the printed circuit board to extend perpendicularly thereto, and a second leg 5b bent perpendicularly to leg 5a in the direction of the cathode 6 and terminating in a pointed tip 5c.

The cathode 6 includes a mounting leg 6a extending parallel to the printed circuit board 3 and mounted directly thereto. Cathode 6 further includes a planar section 6b extending perpendicularly to the printed circuit board and formed with an enlarged opening 6c coaxial with leg 5b and pointed tip 5c of the anode 5.

Thus, a voltage applied between the anode 5 and the cathode 6, which is sufficient to produce a corona discharge from the anode towards the cathode, forms positive ions at the anode 5. These ions are accelerated towards the cathode 6 and produce an ion wind, as shown by arrow 7 in Fig. 2, in the direction of the power transistor 2. This ion wind causes heat dissipation by convection from the power transistor 2, thereby cooling it.

The apparatus of Figs. 1 and 2 may thus be used for cooling individual power transistors mounted on a printed circuit board. For example, one electrode assembly including the anode 5 and cathode 6 may be provided for and adjacent to each power transistor to be cooled.

Figs. 3 and 4 illustrate the invention also applied for cooling a power transistor, but is particularly applicable for larger size power transistors which generate considerable quantities of heat. Thus, the power transistor 10 illustrated in Fig. 3 is mounted on a heat sink 11 carried by the printed circuit board 12. In this case, the electrode assembly producing the ion wind includes a cathode 13 of channel configuration and an anode 14 in the form of a wire both carried by a bracket 15 mounted to the printed circuit board 12 in alignment with the power transistor 10 and the heat sink 11 to be cooled.

As shown particularly in Fig. 4, the cathode 13 includes a main planar section 13a formed with a longitudinally-extending rectangular slot 13b, two wing sections 13c, 13d along the opposite longitudinal edges of the slot, and a mounting section 13e fixed to the printed circuit board 12. The wing sections 13c, 13d are angled towards, but terminate short of, each other to produce an airgap 14 between the confronting edges of the two wing sections.

The anode 15 is in the form of a wire secured between two terminals 15a, 15b and extending along the slot

13b of the main cathode section 13a between its wing sections 13c, 13d.

The printed circuit board 12 further includes connectors, shown schematically at 17, for making the electrical connections to the power transistor 10, as well as to the electrodes 13 and 15.

When the appropriate voltage is applied between the cathode 13 and the anode 15, positive ions are produced at the anode 15. These positive ions are accelerated and are directed by the cathode wing sections 13c, 13d to produce an ion wind through the gap 14 for cooling the power transistor 10 and its heat sink 11.

Figs. 5 and 6 illustrate the invention as applied for cooling a power hybrid regulator 21 mounted on a chassis or printed circuit board 22 by means of a plurality of spacers 23. In this case, the ion wind for cooling the regulator 21 is produced by an electrode assembly including a cathode 24 and a pair of anodes 25, 26, mounted between the chassis or printed circuit board 22 and the power hybrid regulator 21 to be cooled.

Thus, the cathode 24 is of planar configuration and is mounted to the chassis or printed circuit board 22 by a spacer 27. The cathode 24 is formed with a pair of circular openings 24a, 24b, each receiving the pointed tip of the anode electrodes 25, 26 and coaxial therewith, as described above with respect to Figs. 1 and 2. In the construction illustrated in Figs. 5 and 6, an ion wind is

produced by each of the anodes 25, 26 and the common cathode 24, and these ions winds are directed towards the power hybrid regulator 21 to dissipate the heat therefrom by convection, as described above with respect to Figs. 1 and 2.

Fig. 7 illustrates a further application of the invention for cooling an electrical device, such as a power supply, housed within a housing 30. Thus, one end of the housing 30 is formed with an opening 31 occupied by an electrode assembly including a cathode 32 and a plurality of anodes 33, 34, 35, etc. The cathode 32 is common to all of the anodes. Thus, the common cathode 32 includes a main planar section 32a formed with a plurality of longitudinally-extending rectangular slots 32b, one for each of the anodes 33-35. The common cathode 32 is further formed with a pair of wing sections 32c, 32d extending along the opposite longitudinal edges of each slot 32b. The wing sections are angled towards each other but terminate short of each other, similar to the arrangement illustrated in Figs. 3 and 4, such that they accelerate the positive ions produced by the respective anodes 33-35 and direct them into the interior of housing 30 so as to dissipate the heat generated by the electrical device within the housing through the outlet opening 37 formed at the opposite end of the housing.

It will thus be seen that in the construction illustrated in Fig. 7, the anodes 33-35 form, with their

respective cathode wing sections 32c, 32d, a plurality of electrode assemblies extending along one orthogonal axis (shown at A_y) and spaced from each other along a second orthogonal axis (A_z) to generate an ion wind along the third orthogonal axis (A_x).

The illustrated apparatus, and particularly that illustrated in Fig. 7, is especially useful for cooling electrical power supplies or components thereof. It will be appreciated, however, that the invention could advantageously be used with respect to other type of heat-generating bodies, for example bodies wherein the heat is generated by friction, fuel combustion, etc.

Many other variations, modifications and applications of the invention will be apparent.

WHAT IS CLAIMED IS:

1. A method of cooling a heat-generating body, comprising:
generating an ion wind by corona discharge;
and directing said ion wind towards said heat-generating body to dissipate substantial quantities of heat therefrom by convection.
2. The method according to Claim 1, wherein said corona discharge is produced between a pointed anode and a cathode.
3. The method according to Claim 2, wherein said cathode is a planar cathode formed with an opening coaxial with that of said pointed anode.
4. The method according to Claim 1, wherein said corona discharge is produced between a wire anode and a cathode of an electrode assembly.
5. The method according to Claim 4, wherein said cathode includes a planar section formed with a longitudinally-extending rectangular slot having two wing sections extending along the opposite longitudinal edges of the slot, said wing sections being angled towards, but terminating short of, each other; said wire anode being located midway between said wing sections such that said wing sections direct the ion wind towards said heat-generating body.
6. The method according to Claim 5, wherein there are a plurality of said electrode assemblies extending along one orthogonal axis and spaced from each other along a

second orthogonal axis to generate an ion wind along the third orthogonal axis.

7. The method according to any one of Claims 1-6, wherein the method is applied for cooling a power transistor mounted on a printed circuit board.

8. The method according to any one of Claims 1-6, wherein the method is applied for cooling a hybrid electronic device.

9. The method according to any one of Claims 1-6, wherein the method is applied for cooling an electrical power supply.

10. The method according to any one of Claims 1-6, wherein said heat-generating body is located within a housing, and said ion-wind generating means is mounted at one end of said housing and is effective to produce an ion wind passing through said housing and through the opposite end thereof.

11. Apparatus for cooling a heat-generating body, comprising an electrode assembly for generating an ion wind by corona discharge and for directing said ion wind towards said heat-generating body to dissipate heat therefrom by convection.

12. The apparatus according to Claim 11, wherein said electrode assembly comprises a cathode and a pointed anode located adjacent to said cathode.

13. The apparatus according to Claim 12, wherein said cathode is a planar cathode formed with an opening coaxial with said pointed anode.

14. The apparatus according to Claim 11, wherein said electrode assembly comprises a cathode and a wire anode located adjacent to said cathode.

15. The apparatus according to Claim 14, wherein said cathode includes a planar section formed with a longitudinally-extending rectangular slot having two wing sections extending along the opposite longitudinal edges of the slot, said wing sections being angled towards, but terminating short of, each other; said wire anode being located midway between said wing sections such that said wing sections direct the ion wind towards said heat-generating body.

16. The apparatus according to Claim 15, wherein there are a plurality of said electrode assemblies extending along one orthogonal axis and spaced from each other along a second orthogonal axis to generate an ion wind along the third orthogonal axis.

17. The apparatus according to any one of Claims 11-16, wherein said heat-generating body is a power transistor mounted in a printed circuit board.

18. The apparatus according to any one of Claims 11-16, wherein said heat-generating body is a power hybrid regulator.

19. The apparatus according to any one of Claims 11-16, wherein said heat-generating body is a power supply for electrical apparatus.

20. The apparatus according to any one of Claims 11-16, wherein said heat-generating body is located within a

housing, and said ion-wind generating means is mounted at one end of said housing and is effective to produce an ion wind passing through said housing and through the opposite end thereof.

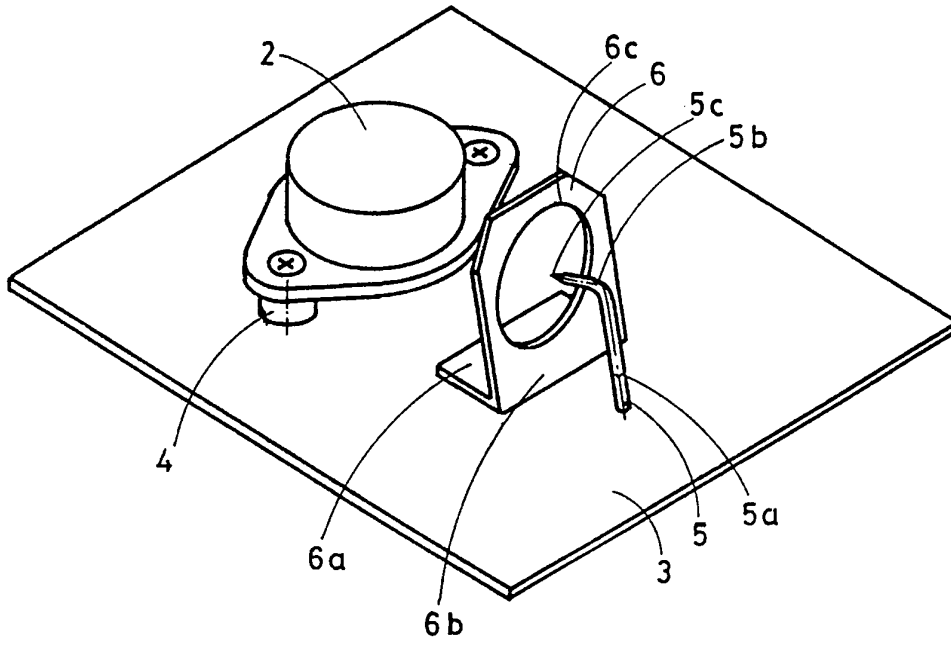

Fig. 1

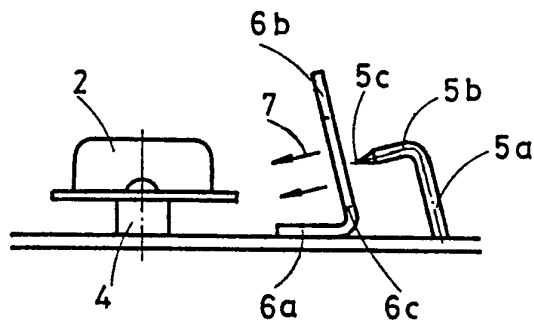

Fig. 2

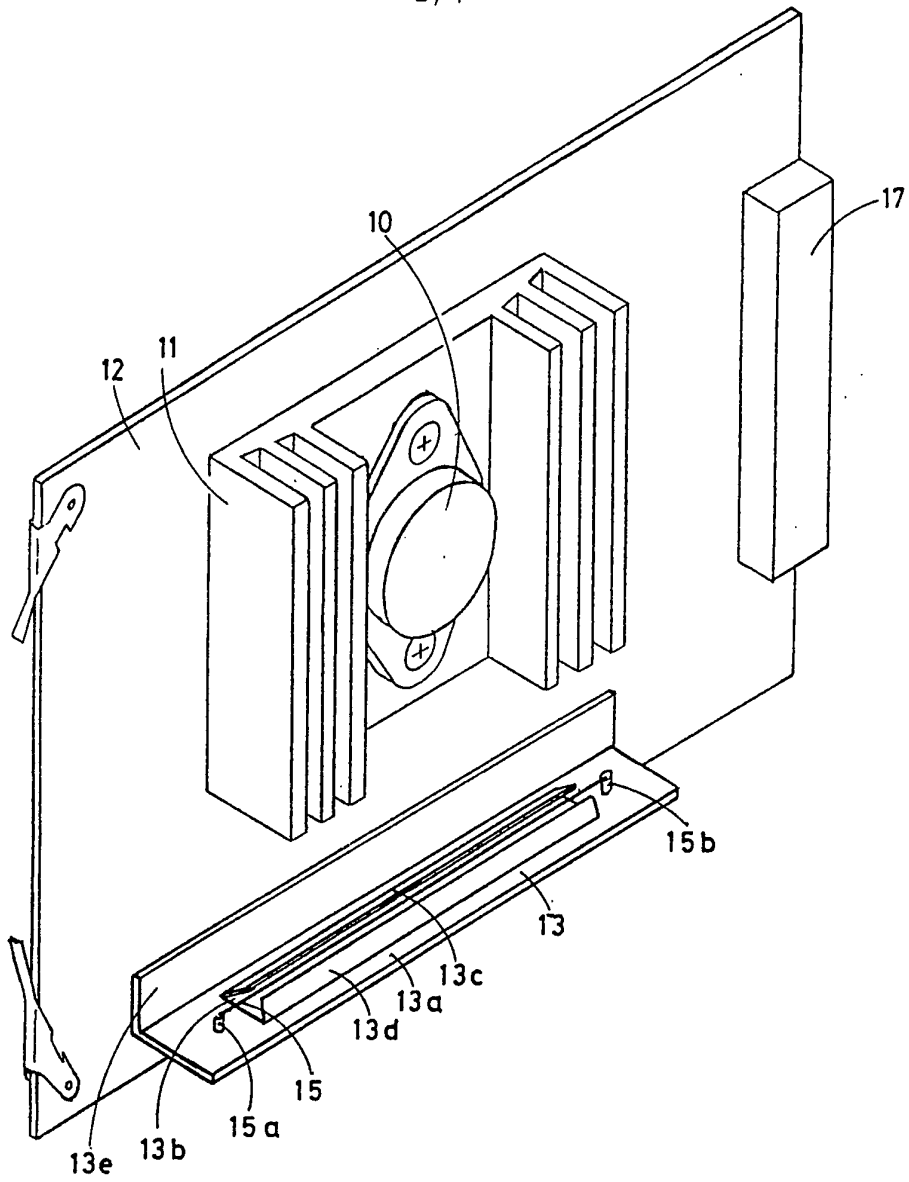

Fig. 3

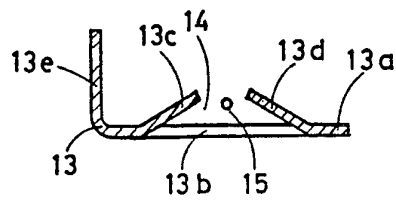

Fig. 4

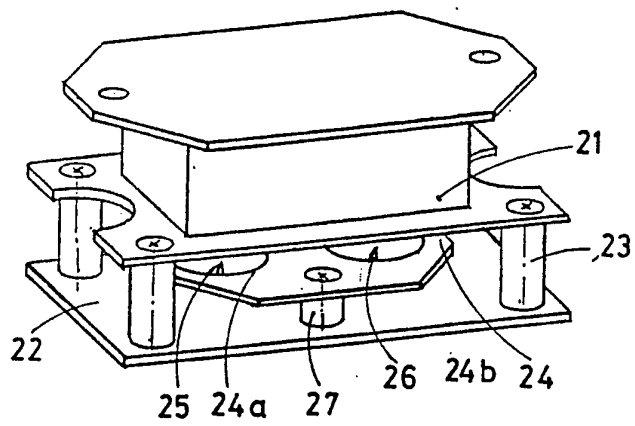

Fig. 5

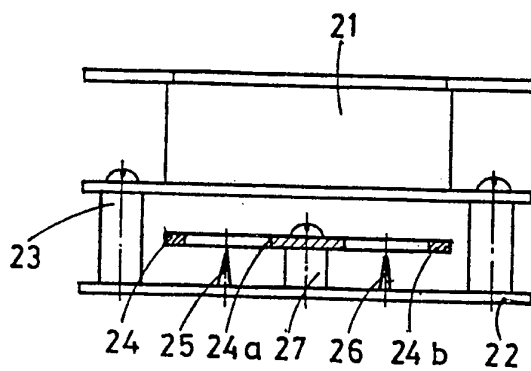

Fig. 6

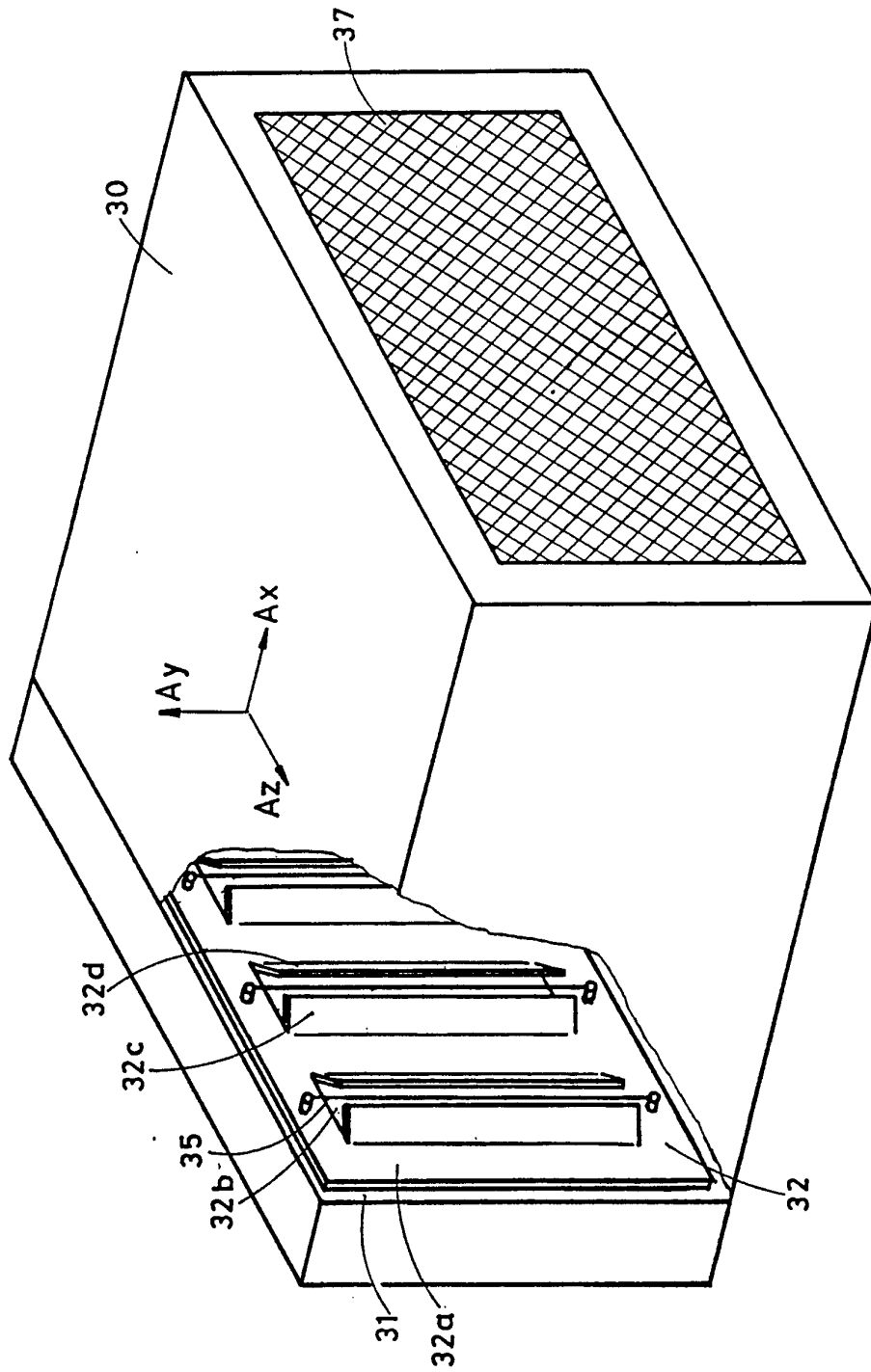



Fig. 7

INTERNATIONAL SEARCH REPORT

International application No.
PCT/US93/11378

A. CLASSIFICATION OF SUBJECT MATTER IPC(5) :B03C 3/00 US CL : 361/230 According to International Patent Classification (IPC) or to both national classification and IPC		
B. FIELDS SEARCHED Minimum documentation searched (classification system followed by classification symbols) U.S. : 361/230, 231, 232, 215, 212; 55/150, 151, 152 Documentation searched other than minimum documentation to the extent that such documents are included in the fields searched Electronic data base consulted during the international search (name of data base and, where practicable, search terms used)		
C. DOCUMENTS CONSIDERED TO BE RELEVANT		
Category*	Citation of document, with indication, where appropriate, of the relevant passages	Relevant to claim No.
Y	US, A, 5,053,912 (Loreth et al) 01 October 1991, fig. 1-3.	1-20
Y	US, A, 5,090,482 (Baron et al) 25 February 1992, claims 1-30.	1-20
A	US, A, 2,477,947 (Yadoff) 02 August 1949, claims 1-6.	1-20
A	US, A, 4,976,752 (Torok et al) 11 December 1990, claims 1-9.	1-20
A	US, A, 4,955,991 (Torok et al) 11 September 1990, fig. 1-4.	1-20
A	US, A, 4,164,901 (Everett) 21 August 1979, Fig. 1-6.	1-20
<input checked="" type="checkbox"/> Further documents are listed in the continuation of Box C. <input type="checkbox"/> See patent family annex.		
*A	document defining the general state of the art which is not considered to be part of particular relevance	*T later document published after the international filing date or priority date and not in conflict with the application but cited to understand the principle or theory underlying the invention
*E	earlier document published on or after the international filing date	*X document of particular relevance; the claimed invention cannot be considered novel or cannot be considered to involve an inventive step when the document is taken alone
*L	document which may throw doubts on priority claim(s) or which is cited to establish the publication date of another citation or other special reason (as specified)	*Y document of particular relevance; the claimed invention cannot be considered to involve an inventive step when the document is combined with one or more other such documents, such combination being obvious to a person skilled in the art
*O	document referring to an oral disclosure, use, exhibition or other means	
*P	document published prior to the international filing date but later than the priority date claimed	*Z document member of the same patent family
Date of the actual completion of the international search 07 March 1994		Date of mailing of the international search report MAR 22 1994
Name and mailing address of the ISA/US Commissioner of Patents and Trademarks Box PCT Washington, D.C. 20231 Facsimile No. NOT APPLICABLE		Authorized officer PETER GANJOO  Telephone No. (703) 308-1655

INTERNATIONAL SEARCH REPORT

International application No.
PCT/US93/11378

C (Continuation). DOCUMENTS CONSIDERED TO BE RELEVANT		
Category*	Citation of document, with indication, where appropriate, of the relevant passages	Relevant to claim No.
A	US, A, 3,184,901 (Main) 25 May 1965, Fig. 1-3.	1-20