

(No Model)

H. A. MACK.
BOBBIN.

No. 584,594.

Patented June 15, 1897.

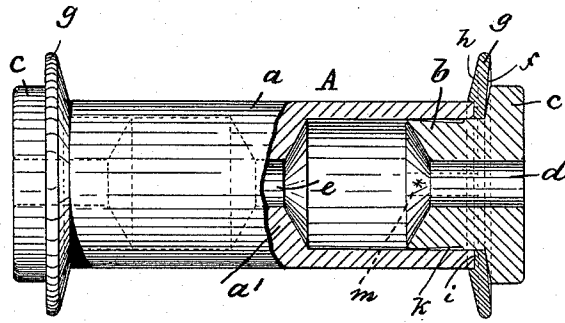

Fig. 1.

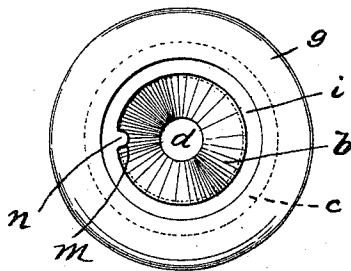

Fig. 2.

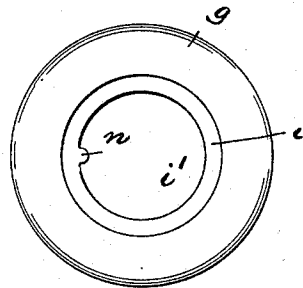

Fig. 3.

WITNESSES:

Wm. J. Bell.
L. Snyder

INVENTOR:

Henry A. Mack

BY *Partner & Co* ATTY'S.

UNITED STATES PATENT OFFICE.

HENRY A. MACK, OF WEATHERLY, PENNSYLVANIA, ASSIGNOR TO THE
H. A. MACK WOOD-WORKING COMPANY, OF SAME PLACE.

BOBBIN.

SPECIFICATION forming part of Letters Patent No. 584,594, dated June 15, 1897.

Application filed March 2, 1897. Serial No. 625,772. (No model.)

To all whom it may concern:

Be it known that I, HENRY A. MACK, a citizen of the United States, residing in Weatherly, county of Carbon, and State of Pennsylvania, have invented certain new and useful Improvements in Bobbins; and I do hereby declare the following to be a full, clear, and exact description of the invention, such as will enable others skilled in the art to which it appertains to make and use the same, reference being had to the accompanying drawings, and to letters of reference marked thereon, which form a part of this specification.

The object of my present invention is to provide a bobbin for silk and other filaments of simple, strong, and durable construction, reliable in operation, and in which bobbins the turning of the end flanges (usually of fiber) is prevented.

The invention consists in the improved bobbin and in the combination and arrangement of the various parts thereof, substantially as will be hereinafter more fully described and finally embodied in the clauses of the claim.

Referring to the accompanying drawings, in which like letters of reference indicate corresponding parts in each of the several views, Figure 1 is an elevation of my improved bobbin, certain portions being broken away and others shown in sections to better illustrate the nature of my said invention; Fig. 2, an inside view of the bushing and flange detached, and Fig. 3 an inside view of the flange proper.

In said drawings, A represents the bobbin, consisting of the cylinder or barrel *a*, the bushings *b*, and flanges *g*. The flanges *g* are penetrated by the central circular opening *i'* and are provided on their inner convex surface *h* with an annular recess *i*, adapted to be engaged by the end portions of the cylinder or barrel *a*. The bushing *b* is provided with a head *c*, the inner convex surface of which is adapted to bear against the outer concave surface of the flange *g*. The bushing *b* is also provided with the centrally-arranged opening or hole *d* in alinement with the central hole or opening *e* of the diaphragm *a'* of barrel *a*.

In the bushing *b* and on one side thereof is arranged a longitudinal groove or recess *m*, corresponding in shape to a lug or projec-

tion on the inner edge of the annular flange *g* and adapted to be engaged thereby, and to thus prevent the said flange from revolving or turning on or around the bushing *b*. The inner portion of each bushing is also provided with a concave annular groove *k*, adapted to form a chamber for the glue or other adhesive material used for securing the said bushing to and within the barrel *a*, as will be manifest.

A bobbin constructed as above described will be strong, light, and durable, in a word, will answer all requirements.

Having thus described my invention, what I claim as new, and desire to secure by Letters Patent, is—

1. A bobbin, consisting of cylindrical barrel, a bushing arranged in each end thereof and provided with a head or enlargement and on its inwardly-projecting portion with a longitudinal groove or recess, and of an annular flange intermediately arranged between the end of the barrel and the head or enlargement of the bushing and provided on its inner edge with a lug or projection, adapted to engage said groove or recess, substantially as and for the purposes described.

2. In a bobbin, the combination with the cylindrical barrel, of a bushing in each end thereof, and provided with a longitudinal groove or recess, and an annular flange on said bushing and provided with a recess adapted to engage the end of said barrel, and with a lug or projection adapted to engage said longitudinal groove or recess, substantially as and for the purposes described.

3. A bobbin consisting of a cylindrical barrel, a bushing in the end thereof and provided with a head or enlargement, an annular flange intermediately arranged between the end of the barrel and the head or enlargement, and means on said flange and bushing and forming a part of the same for preventing relative rotation, substantially as described.

In testimony that I claim the foregoing I have hereunto set my hand this 23d day of February, 1897.

HENRY A. MACK.

Witnesses:

ALFRED GARTNER,
WM. D. BELL.