

(19) **DANMARK**

(10) **DK/EP 2565449 T4**



(12) **Oversættelse af ændret  
europæisk patentskrift**

Patent- og  
Varemærkestyrelsen

- 
- (51) Int.Cl.: **F 03 D 11/00 (2006.01)** **G 01 N 25/72 (2006.01)**
- (45) Oversættelsen bekendtgjort den: **2021-03-22**
- (80) Dato for Den Europæiske Patentmyndigheds bekendtgørelse om opretholdelse af patentet i ændret form: **2021-01-13**
- (86) Europæisk ansøgning nr.: **12182635.8**
- (86) Europæisk indleveringsdag: **2012-08-31**
- (87) Den europæiske ansøgnings publiceringsdag: **2013-03-06**
- (30) Prioritet: **2011-09-01 DE 102011111789** **2011-11-18 DE 102011118833**
- (84) Designerede stater: **AL AT BE BG CH CY CZ DE DK EE ES FI FR GB GR HR HU IE IS IT LI LT LU LV MC MK MT NL NO PL PT RO RS SE SI SK SM TR**
- (73) Patenthaver: **Rolawind GmbH, Marienthalerstr 17 , 24340 Eckernförde, Tyskland**
- (72) Opfinder: **Zell, Horst, Am Wambach 12, 45481 Mühlheim, Tyskland**
- (74) Fuldmægtig i Danmark: **Holme Patent A/S, Valbygårdsvej 33, 2500 Valby, Danmark**
- (54) Benævnelse: **Fremgangsmåde og apparat til termisk overvågning af vindmøllers struktureltilstand**
- (56) Fremdragne publikationer:  
**US-A1- 2010 103 260**  
**MEINLSCHMIDT P ET AL: "Thermographic inspection of rotor blades", INTERNET CITATION, 26. September 2006 (2006-09-26), Seiten 1-9, XP002525987, ISSN: 1435-4934 Gefunden im Internet: URL:http://www.ndt.net/article/ecndt2006/d oc/Tu.1.5.3.pdf [gefundet am 2009-04-29]**  
**Georg Dittié ET AL: "Umwelteinflüsse auf die Genauigkeit von Gebäudethermografien", , 28. September 2007 (2007-09-28), XP055131762, Gefunden im Internet: URL:http://www.ndt.net/article/dgzfp-irt-2 007/Inhalt/v01.pdf [gefundet am 2014-07-25]**  
**WO-A1-2006/074690**  
**WO-A1-2009/071056**  
**WO-A1-2010/051278**  
**WO-A1-2011/113402**  
**DE-A1- 10 022 568**  
**US-A1- 2003 127 862**  
**MEINLSCHMIDT, P.; et al.: "Thermographic Inspection of Rotor Blades", Journal of Non-destructive Testing;, 25 September 2006 (2006-09-25), pages 1-9, Berlin ISSN: 1435-4934 Retrieved from the Internet: URL:http://www.ndt.net/article/ecndt2006/d oc/Tu.1.5.3.pdf**  
**"Internetauftritt der IHK Nürnberg für Mittelfranken entnommen", WiM - Wirtschaft in Mittelfranken, January 2006 (2006-01), page 49;, Retrieved from the Internet: URL:https://www.ihk-nuernberg.de/de/IHK-Ma gazin-WiM/WiM-Archiv/WIM-Daten/2006- 01/Unternehmen-und-Personen/Technologiefue hrer-bei-Infrarot-Kameras.jsp**  
**RUTZ, F.; et al.: "Non-Destructive Testing of Glass-Fibre Reinforced Polymers using Te- rahertz Spectroscopy", Journal of Non-destructive Testing, 25 September 2006 (2006-09-25), pages 1-8, Berlin ISSN: 1435-4934 Retrieved from the Internet: URL:Journal of Nondestructive Testing**

Fortsættes ...



## Description

**[0001]** The invention relates to a method for checking the structural condition of wind turbines in the form of wind turbines comprising multiple rotor blades, whereby the wind turbines or rotor blades are registered by one or more thermographic recording devices installed on or in a mobile location, and the thereby determined measured values are evaluated with regard to any damage.

**[0002]** As part of the growing importance of renewable energies, in recent years the building of wind turbines has increased across the globe. Due to the fact that prevailing strong winds exist over water, in particular the seas, more and more offshore wind turbines are being built. This brings with it the decisive advantage that they are built in less attractive locations in order to not affect the landscape. Like any other industrial plants, wind turbines must also have maintenance checks at regular intervals. This is particularly important for wind turbines as they are exposed to high dynamic loads. Checks of the structural condition of all of the rotor blades must be carried out in a comparatively short space of time.

**[0003]** These inspections are particularly problematic for offshore wind turbines in sea routes, because the employees must travel by boat to each wind turbine. Considerable acrobatic skills are required to carry out the inspection work on the rotor blades, as the workers must have completed high altitude mountain training or industrial climbing training similar to mountain climbers. Moreover, a prerequisite for the inspection is that each rotor blade must be at least approximately in the six o'clock position. Once the inspection on the first rotor blade is completed, the wind turbine must be rotated and the next rotor blade to be checked must be brought into the six o'clock position. It is obvious that this requires a great deal of effort. DE 10 2010 048 400.8 or WO 2011/113402 A1 specifies a method and a device to check the structural conditions of wind turbines in the form of wind turbines comprising multiple rotor blades. Aircrafts, usually helicopters, are used for this. These have suitable recording devices, for example in the form of on-board thermal imaging cameras on board by which the data necessary for the inspection are registered. Through this, it has emerged that the measured values taken for the rotor blades – completely independent of any damages - are in part grossly distorted. This in turn is

particularly relevant due to the thermal stresses on the rotor blades, which go hand in hand with their operation. This means that due to the friction created with the air on rotation, the rotor blades are thermally stressed; they warm up or rather they heat up and namely distributed unevenly across the contours of the rotor blades. A similar  
5 method of use of a drone is laid out in US 2010/013260 A1.

**[0004]** Thus the object of the present invention is to create a method for checking the structural condition of wind turbines by means of thermographic recording devices, where the measured values are determined as exact as possible.  
10

**[0005]** This object is achieved by the fact that the determined measured values are evaluated by taking into account the thermal stresses caused by the operation of the rotor blades at the time of measurement.

**[0006]** During normal operation in the form of the rotation of the rotor blades and the movement of other dynamically stressed building part, notable thermal stresses are present. These depend largely on the friction between the rotor blades and the air during rotation. Due to acceleration errors, which can be caused by the rotation, false deviations can occur. The associated measurement errors significantly influence the  
15 measurement results of the thermographic recording devices. Therefore, the determined measured values are first evaluated or output when the thermal stresses caused by the operation of the rotor blades during their rotation are taken into consideration accordingly. In doing so, any stresses present at the time of  
20 measurement are effectively turned off. In taking these stresses into consideration we achieve a three-dimensional, spatial and positional precise evaluation and  
25 documentation.

**[0007]** Specifically, this means that the data regarding the thermal stresses present at the time of measurement is placed in relation to the determined measured values.  
30 This means that on one hand, absolute measured values are registered by the thermographic device. However, these must then be set in relation to data by means of which any thermal stresses on the rotor blades at the time of the measurements are taken into account. In other words, the data that are subject to external influences such as air friction, weather conditions, temperature, season etc. must be down-

calculated from the thermographically determined measured values. What then remains is the actual measured values, which can be used to deduce the actual damage of the rotor blades.

5 **[0008]** Eventually, this then leads to the fact that the measured values are output taking into account the data that was set in relation to them, i.e. after processing the temperature measurement errors using a special software and an associated correction follows then evaluation and output set in relation, i.e. revised or corrected measured values. The raw data of the measurement results are significantly affected  
10 by the operation of the rotor blades, i.e. by their rotation, during which they warm up or heat up due to the air friction. According to the invention, it is provided to take into account the thermal stresses caused by friction during operation of the rotor blades. The same applies to other forms of thermal stress such as solar radiation, external temperature etc.

15

**[0009]** To a certain extent these stresses can be standardised, as the thermal loads of the rotor blades comply with certain laws, in particular those for thermal stresses caused by air friction. With this in mind, it is suggested that the thermal stresses should be taken into account separately for segments of the rotor blades.

20

**[0010]** According to an embodiment of the invention, it is provided that the rotor blades are divided into segments, sections or zones in their lateral axial direction. Thus, it is expedient to divide the rotor blades in the lateral axial direction. Subsequently, in the course of the evaluation, the individual segments are assigned  
25 to the respective rotor blade and, as far as possible, combined to form a complete representation or representative partial representation.

**[0011]** The lateral direction of the rotor blades is of particular importance due to the high correctional needs with regard to the measured values registered by the  
30 thermographic recording devices. It is thus provided that in the lateral direction of a rotor blade, at least the front edge, blade surface and back edge of the segments of the rotor blade are taken into account. Due to the rotation of the rotor blades, the air flow, especially at the front edge of the rotor blades, experiences a high acceleration, air particles and rotor blades in this area are also particularly heated, which bring with

it the need for high correction requirements in relation to the measurement results. Through a reduction of the acceleration on the actual blade surface, the temperature development in this area is usually lower. It then increases again in the direction towards the back edge, however to a lesser extent compared with the front edge.

5 These standardised data for recording the temperature of the rotor blade during operation must be taken into account and subtracted when outputting the final measurement data in order to avoid incorrect measurement results.

**[0012]** In order to record the thermographic measure values, a model approved  
10 aircraft or manned aircraft such as a helicopter, a balloon, a zeppelin, a kite or a drone is intended as a mobile location. Model helicopters / drones (unmanned aircraft) of less than 25 kg do not require a traffic permit and are not used to examine the structural condition.

15 **[0013]** The data are registered from a preferred distance of approx. 0.01 to 10,000 m between the rotor blades and the recording device.

**[0014]** In a preferred exemplary embodiment, the device for carrying out the method according to the invention comprises five components. First, a type-certificated  
20 aircraft or a manned aircraft such as a helicopter, a balloon, a zeppelin, a kite or a drone and one or more thermographic recording devices are needed. These are to be used in parallel with other thermographic devices or other devices based on e.g. radar, ultrasonic, terahertz, laser technology or 3D scanning, whereby the latter is used to produce special three-dimensional recordings. In this manner, it is possible to  
25 record from different angles. All the pictures, also registered by means of different techniques - e.g. thermal, terahertz, 3D scanning, laser, radar, ultrasonic and/or infrared technology, preferably dual-band infrared technology - can be superimposed to create a result. In doing so, the position of the measured object in the depth of the rotor blades can be precisely determined. Compact casings serve to house one or  
30 more of these recording devices. The helicopter flies over the rotor blades individually or altogether regardless of their position and their otherwise condition. Then follows a scanning of the individual rotor blades, preferably with terahertz waves, to for example register the material density of the rotor blades. In particular, this method can also provide good depth information. An advantage is that the scan

can take place even on dirty installations that e.g. have been affected by salt crystals. As a third component, the device comprises a unit for (temporarily) storing the data, and as a fourth, the unit according to the invention by which the determined measured values are evaluated taking into account the determined thermal stresses caused by the operation of the rotor blades at the time of measurement. This expediently follows in a separate and automatic method step prior to the actual output of the measured values, through which, for example, the damage of the rotor blades then can be deduced. Finally, the device comprises a unit for outputting the final, corrected, calculated measured values taking into account the special thermal stresses of the rotor blades during their operation, which then enable the evaluating staff to literally get a picture of the structural condition of the rotor blades that were checked.

**[0015]** According to a further variation of the invention, it has been considered that data registered by scanning and thermographic measurement can be put in relation to one another. For the scanned item, such as rotor blade, nacelle housing, tower or bridge, the thermographic measurements can be displayed in order to locate the positions of individual damages.

**[0016]** The invention is therefore characterised in particular by the fact that a method for checking the structural condition of structures such as buildings, towers, masts, bridges and in particular of wind turbines is created. In addition to the tower and nacelle housing of a wind power plant, the invention revolves around wind turbines, especially those in offshore wind power plants, where measurement data registered by a thermographic recording device can be corrected. Thereby is a three-dimensional, spatial and positional precise evaluation and documentation possible. The correction follows in the form of placing data in relation to the thermographic determined measured values, through which the thermal stresses caused by the operation of the rotor blades at the time of measurement, in particular due to friction due to the rotation of the rotor blades, can be taken into account. With the support of a helicopter, a flexible use is possible, that in particular is completely independent on the shape, type and size of the wind turbine to be checked. The use is conceivable for a rotor blade that rotates on a horizontal axis as well as one that rotates on a vertical axis.

**[0017]** Further details and advantages of the subject matter of the invention arise from the following description of the accompanying drawing, in which a preferred exemplary embodiment with the necessary details and individual parts is shown.

5

**[0018]** It shows:

Figure 1 a helicopter in action at a wind turbine,

Figure 2 a rotor blade,

Figure 3 a section of this rotor blade.

10

**[0019]** Figure 1 shows a wind turbine 1 as part of a wind power plant in a body of water, illustrated by the water level and indicated by the reference symbol 15. The wind turbine 1 comprises a tower 5 anchored in the seabed and/or floating, on which the actual wind turbine is positioned. The reference symbols 3 and 4 show two rotor blades that can rotate about a horizontal axis 17, 7 is the hub and 8 the so-called nacelle, which is rotatable arranged on the yaw control 9. This wind turbine 1, more precisely its rotor blade 4, the tower 5 or the nacelle 8, in the illustration according to Figure 1, is registered by a helicopter 2 or a thermographic recording device 11 installed on it and designed as a camera 6. Registration using terahertz waves, 3D scanning or laser technology is also conceivable. The positioning of rotor blades 3, 4 is just as unimportant as their condition, in particular the rotor blades 3, 4 do not need to be freed from impurities before the registration shown here.

**[0020]** In Figure 2, one such rotor blade 3 with segments extending in its longitudinal axis 17 is shown, here there are four segments 20 to 23.

**[0021]** Finally, Figure 3 shows the segment provided in Figure 2 with the reference symbol 22 or the corresponding section between the two lateral axes 18' and 18" in an enlarged view. Thermal stresses, i.e. points, that warm up due to the friction caused by the rotation of the rotor blades, are shown as peaks. These are located in particular at the front edge 24 of the rotor blade 3 and are exemplarily provided with the reference symbols 27, 28 and 29. In the direction of the blade surface 25, the thermal load decreases significantly; the acceleration is lower and the temperature increase is accordingly lower. The thermal stress then increases again in the

30

direction toward the back edge 26 of the rotor blade 3, symbolised by the peaks 30, 31, 32, which however in relation to the peaks 27, 28 and 29 at the front edge 24 of the rotor blade 3 are significantly lower. With the method according to the invention, the final measurement results are adjusted by the data relating to the thermal stress.

- 5 The evaluation of any damage to the rotor blades therefore follows taking into consideration these thermal stresses, as exemplified in Figure 3.

## Patentkrav

1. Fremgangsmåde til under normal drift at overvåge den strukturelle tilstand af vindmøller i form af rotor (1) med flere rotorblade (4), idet vindmøllerne overvåges af en eller flere termografiske registreringsanordninger (6) installeret på og/eller i en mobil placering, og med henblik på eventuelle skader evalueres de derved målte værdier under hensyntagen til termiske belastninger forårsaget af rotorbladenes (4) drift på måletidspunktet, kendetegnet ved at der tages hensyn til de termiske belastninger på rotorbladene (4), som under rotorbladenes (4) drift følger af friktionen med luften ved rotationen, idet rotorbladene (4) opvarmes ulige fordelt over deres konturer som følge af luftstrømmen ved forkanten, på bladoverfladen og i retning mod bagkanten, hvorved der tages særskilt hensyn til termiske belastninger i henhold til segmenter af rotorbladet (4), og der i et rotorblads (4) tværgående akseretning tages hensyn til i det mindste segmenternes forkant (24), bladoverflade (25) og bagkant (26), og en temperaturabsorption i rotorbladet (4), som under drift er bevirket af disse termiske belastninger, fjernes fra outputtet af slutmåledataene.  
5  
10  
15  
20
2. Fremgangsmåde ifølge krav 1, kendetegnet ved, at et typecertificeret luftfartøj og/eller bemanded luftfartøj, såsom en helikopter, en ballon, en zeppeliner, en drage eller en drone, anvendes som mobil placering.  
25
3. Fremgangsmåde ifølge krav 1, kendetegnet ved, at de termografiske registreringer fremstilles ved hjælp af dual-band infrarød teknologi.
- 30 4. Fremgangsmåde ifølge krav 1, kendetegnet ved, at data registreret ved scanning og termografisk måling sættes i forhold til hinanden.

Fig.1

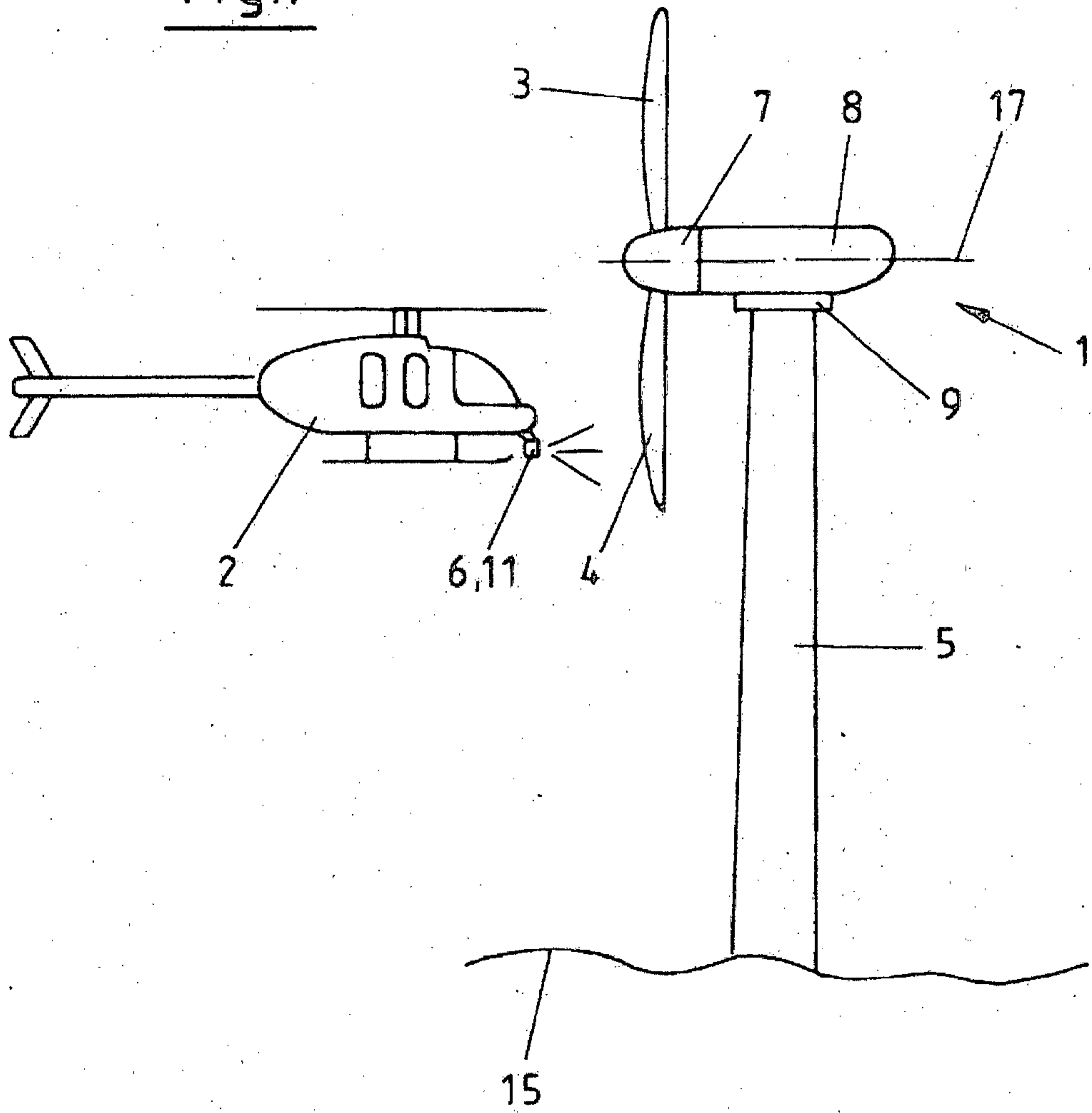

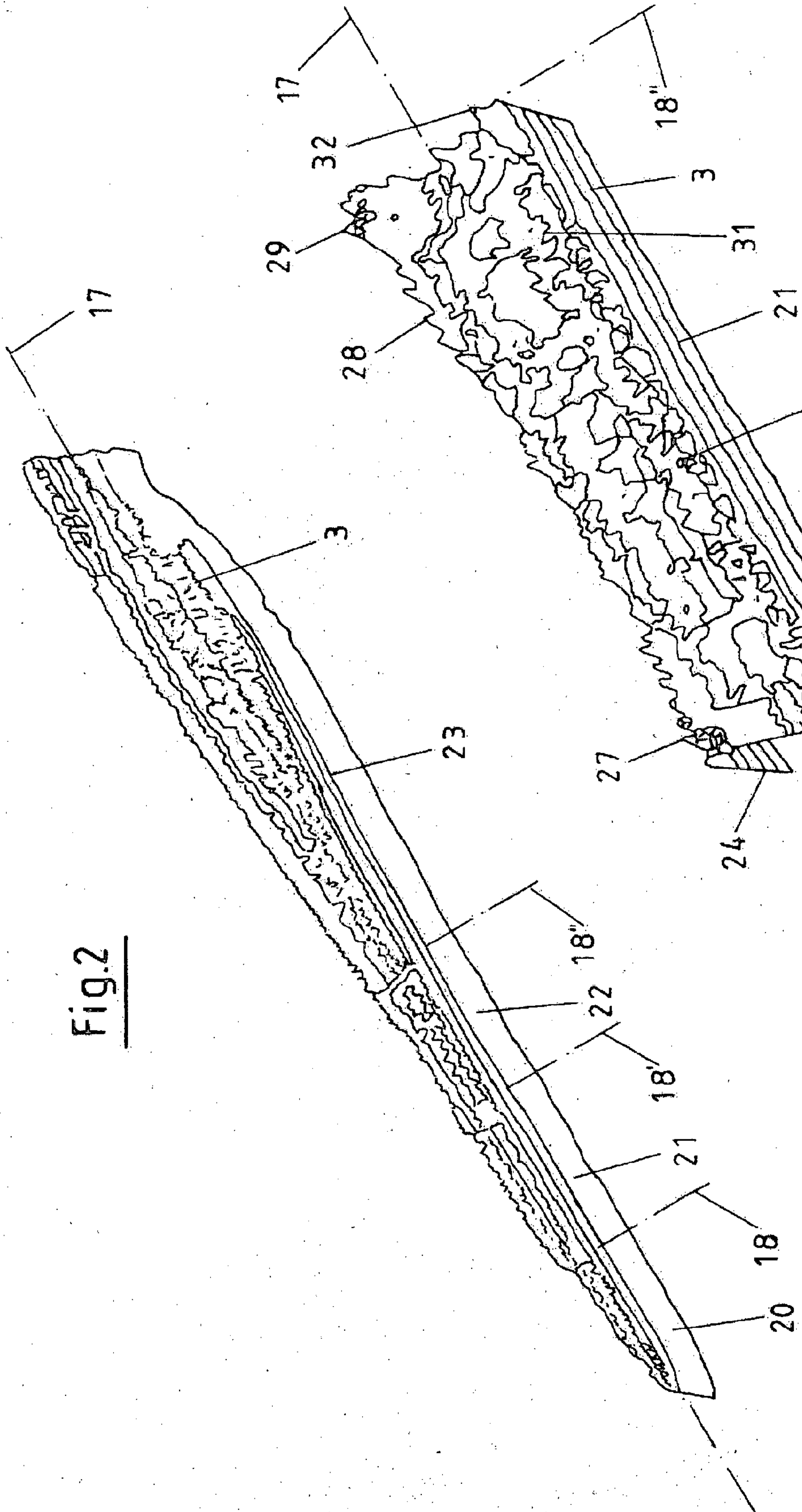

Fig. 2

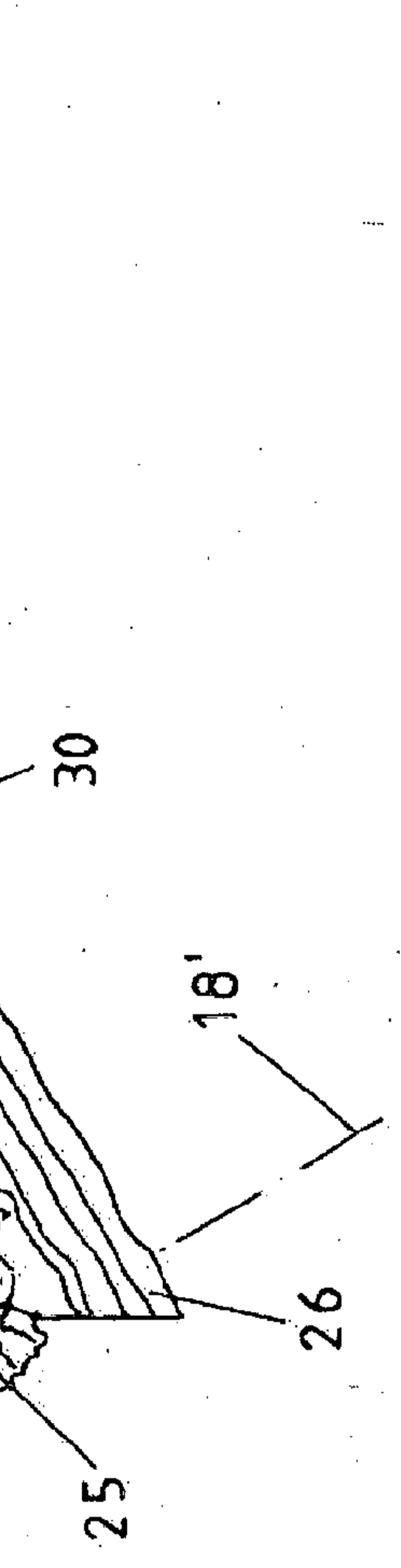

Fig. 3