

CORRECTED VERSION

(19) World Intellectual Property Organization  
International Bureau



(43) International Publication Date  
8 February 2007 (08.02.2007)

PCT

(10) International Publication Number  
WO 2007/016533 A3

(51) International Patent Classification:  
A61F 2/16 (2006.01)

(21) International Application Number:  
PCT/US2006/029852

(22) International Filing Date: 31 July 2006 (31.07.2006)

(25) Filing Language: English

(26) Publication Language: English

(30) Priority Data:  
11/195,422 1 August 2005 (01.08.2005) US

(71) Applicant (for all designated States except US): VISIO-  
GEN, INC. [US/US]; 4 Jenner Street, Suite 180, Irvine,  
California 92618 (US).

(72) Inventors; and

(75) Inventors/Applicants (for US only): NGUYEN, Tuan,  
Anh [US/US]; 2418 E. Karan Lane, Orange, California  
92869 (US). ZADNO-AZIZI, Gholam-Reza [US/US];  
47066 Palo Amarillo Drive, Fremont, California 94539  
(US). EVANS, Scott [US/US]; 1252 Country Hills Drive,  
Santa Ana, California 92705 (US). PORTNEY, Valdemar  
[US/US]; 11940 N. Riviera, Tustin, California 92782 (US).

(74) Agent: DELANEY, Karoline, A.; Knobbe, Martens, Ol-  
son & Bear, LLP, 2040 Main Street, 14th Floor, Irvine, Cal-  
ifornia 92614 (US).

(81) Designated States (unless otherwise indicated, for every  
kind of national protection available): AE, AG, AL, AM,  
AT, AU, AZ, BA, BB, BG, BR, BW, BY, BZ, CA, CH, CN,  
CO, CR, CU, CZ, DE, DK, DM, DZ, EC, EE, EG, ES, FI,  
GB, GD, GE, GH, GM, HN, HR, HU, ID, IL, IN, IS, JP,  
KE, KG, KM, KN, KP, KR, KZ, LA, LC, LK, LR, LS, LT,  
LU, LV, LY, MA, MD, MG, MK, MN, MW, MX, MZ, NA,  
NG, NI, NO, NZ, OM, PG, PH, PL, PT, RO, RS, RU, SC,  
SD, SE, SG, SK, SL, SM, SY, TJ, TM, TN, TR, TT, TZ,  
UA, UG, US, UZ, VC, VN, ZA, ZM, ZW.

(84) Designated States (unless otherwise indicated, for every  
kind of regional protection available): ARIPO (BW, GH,  
GM, KE, LS, MW, MZ, NA, SD, SL, SZ, TZ, UG, ZM,  
ZW), Eurasian (AM, AZ, BY, KG, KZ, MD, RU, TJ, TM),  
European (AT, BE, BG, CH, CY, CZ, DE, DK, EE, ES, FI,  
FR, GB, GR, HU, IE, IS, IT, LT, LU, LV, MC, NL, PL, PT,  
RO, SE, SI, SK, TR), OAPI (BF, BJ, CF, CG, CI, CM, GA,  
GN, GQ, GW, ML, MR, NE, SN, TD, TG).

Published:  
— with international search report

[Continued on next page]

(54) Title: ACCOMMODATING INTRAOCULAR LENS SYSTEM WITH ABERRATION-ENHANCED PERFORMANCE

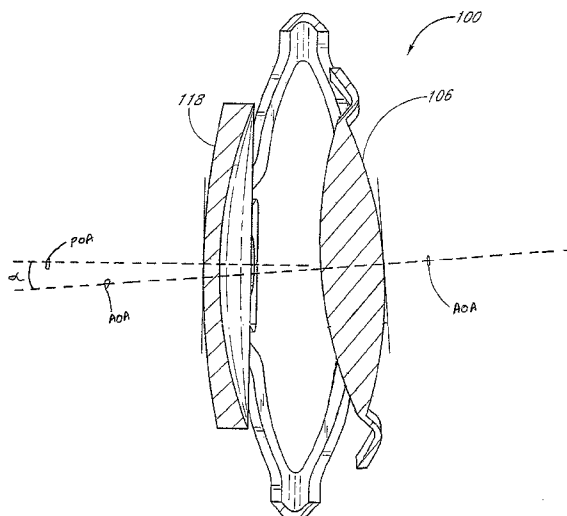

(57) Abstract: An accommodating intraocular lens (100) implantable in an eye. The lens comprises an anterior portion having an anterior biasing element and an anterior optic having refractive power (106). The lens further comprises a posterior portion having a posterior biasing element and a posterior optic having refractive power (118). The anterior optic and the posterior optic are relatively moveable in response to action of the ciliary muscle to change the separation between the optics and the refractive power of the lens. The lens has an aberration-inducing force characteristic of about 70 mg to about 115 mg to allow aberration-inducing relative movement of the optics when the lens is in the eye, thereby adding optical aberration to the lens which increases depth of focus of the lens. In one variation, the lens has an aberration-inducing force characteristic of 70 mg to 115 mg. Related methods are also disclosed.

WO 2007/016533 A3



**(88) Date of publication of the international search report:**  
5 April 2007

**(15) Information about Correction:**  
see PCT Gazette No. 28/2007 of 12 July 2007

**(48) Date of publication of this corrected version:**  
12 July 2007

*For two-letter codes and other abbreviations, refer to the "Guidance Notes on Codes and Abbreviations" appearing at the beginning of each regular issue of the PCT Gazette.*

**ACCOMMODATING INTRAOCULAR LENS SYSTEM WITH ABERRATION-  
ENHANCED PERFORMANCE**

Related Applications

[0001] This application is a continuation-in-part of U.S. Patent Application No. 10/207,717 (now U.S. Patent Application Publication No. US 2003/0078657 A1), filed July 25, 2002, titled MATERIALS FOR USE IN ACCOMMODATING INTRAOCULAR LENS SYSTEM, which is a continuation-part of U.S. Patent Application No. 10/020,853 (now U.S. Patent Application Publication No. US 2002/0107568 A1), filed December 11, 2001, titled ACCOMMODATING INTRAOCULAR LENS SYSTEM, which claims the benefit of U.S. Provisional Patent Applications No. 60/337,343, filed November 9, 2001 and titled ACCOMMODATING INTRAOCULAR LENS SYSTEM; No. 60/283,856, filed April 13, 2001 and titled ACCOMMODATING INTRAOCULAR LENS SYSTEM; and No. 60/264,179, filed January 25, 2001 and titled ACCOMMODATING INTRAOCULAR LENS SYSTEM. This application is a continuation-part of U.S. Patent Application No. 10/017,920 (now U.S. Patent Application Publication No. US 2002/0116057 A1), filed December 11, 2001, titled OPTIC CONFIGURATION FOR INTRAOCULAR LENS SYSTEM, which claims the benefit of U.S. Provisional Patent Applications No. 60/337,343, filed November 9, 2001 and titled ACCOMMODATING INTRAOCULAR LENS SYSTEM; No. 60/283,856, filed April 13, 2001 and titled ACCOMMODATING INTRAOCULAR LENS SYSTEM; and No. 60/264,179, filed January 25, 2001 and titled ACCOMMODATING INTRAOCULAR LENS SYSTEM. This application is a continuation-part of U.S. Patent Application No. 10/958,871, filed October 5, 2004, titled INTRAOCULAR LENS, which claims the benefit of U.S. Provisional Patent Application No. 60/563,238, filed April 16, 2004 and titled INTRAOCULAR LENS. This application is a continuation-part of U.S. Patent Application No. 11/057,705, filed February 14, 2005, titled BIASING SYSTEM FOR INTRAOCULAR LENS. The entire disclosure of all of the above-mentioned prior patent applications, provisional patent applications, and patent application publications is hereby incorporated by reference herein and made a part of this specification.

## Background of the Invention

### Field of the Invention

[0002] Certain disclosed embodiments relate to intraocular lenses and, more particularly, to intraocular lenses that alter their refractive power in response to action of the ciliary muscle of the eye.

### Description of the Related Art

[0003] The vast majority of cataract operations involve the implantation of an artificial lens following cataract removal. Typically these lenses have a fixed focal length or, in the case of bifocal or multifocal lenses, have several different fixed focal lengths. Such fixed focal-length lenses lack the ability of the natural lens to dynamically change the refractive power of the eye. Certain embodiments of the intraocular lens disclosed herein provide an accommodating lens system which alters its refractive power in response to action of the ciliary muscle, thereby allowing the lens system to bring into focus on the retina images of objects that are both near and far from the eye.

### Summary of the Invention

[0004] One aspect of the invention is an accommodating intraocular lens implantable in an eye. The lens comprises an anterior portion having an anterior biasing element and an anterior optic having refractive power. The lens further comprises a posterior portion having a posterior biasing element and a posterior optic having refractive power. The anterior optic and the posterior optic are relatively moveable in response to action of the ciliary muscle to change the separation between the optics and the refractive power of the lens. The lens has an aberration-inducing force characteristic of about 70 mg to about 115 mg to allow aberration-inducing relative movement of the optics when the lens is in the eye, thereby adding optical aberration to the lens which increases depth of focus of the lens. In one variation, the lens has an aberration-inducing force characteristic of 70 mg to 115 mg.

[0005] Another aspect of the invention is an accommodating intraocular lens implantable in an eye having an optical axis. The lens comprises an anterior portion having an anterior biasing element and an anterior viewing element. The anterior viewing element comprises an optic having refractive power. The lens further comprises a posterior portion having a posterior viewing element. The anterior biasing element is attached to the periphery of the anterior viewing element at substantially diametrically

opposed first and second attachment locations. The periphery of the anterior viewing element is unattached to the anterior biasing element between the first and second attachment locations. The size of the first and second attachment locations is sufficiently small such that the optical axis of the anterior optic tilts and/or decenters relative to the optical axis of the eye during movement of the anterior optic relative to the posterior viewing element.

[0006] Another aspect of the invention is an accommodating intraocular lens system. The lens system comprises an anterior optic having a positive refractive power. The anterior optic has an anterior optical axis. The lens system further comprises a posterior optic having a negative refractive power. The posterior optic has a posterior optical axis. The optics are mounted to move generally along an anterior-to-posterior direction relative to each other in response to ciliary muscle action. The optics have within their range of relative motion a first configuration in which the anterior optical axis is sufficiently misaligned relative to the posterior optical axis to introduce optical aberration in the lens that increases depth of focus relative to the depth of focus that would exist if the axes of the optics were aligned.

[0007] Another aspect of the invention is method of manufacturing an accommodating intraocular lens. The method comprises configuring biasing elements of the lens such that, when implanted, (i) an anterior optic of positive refractive power moves relative to a posterior optic of negative refractive power to change the separation between the optics along an anterior-to-posterior direction, and (ii) the anterior optic tilts and/or decenters relative to a posterior optical axis during relative movement of the optics so as to provide accommodation greater than that due to the refractive power and separation changes alone.

[0008] Each of these aspects is intended to be within the scope of the invention herein disclosed. These and other aspects of the invention will become readily apparent to those skilled in the art from the following detailed description of preferred embodiments having reference to the attached figures, the invention not being limited to any particular preferred embodiment(s) disclosed.

#### Brief Description of the Drawings

[0009] Having thus summarized the general nature of the invention, certain preferred embodiments and modifications thereof will become apparent to those skilled in

the art from the detailed description herein having reference to the figures that follow, of which:

[0010] Figure 1 is a sectional view of the human eye, with the lens in the unaccommodated state.

[0011] Figure 2 is a sectional view of the human eye, with the lens in the accommodated state.

[0012] Figure 3 is a perspective view of one embodiment of an intraocular lens system.

[0013] Figure 4 is a side view of the lens system.

[0014] Figure 5 is a rear perspective view of the lens system.

[0015] Figure 6 is a front view of the lens system.

[0016] Figure 7 is a rear view of the lens system.

[0017] Figure 8 is a top view of the lens system.

[0018] Figure 9 is a side sectional view of the lens system.

[0019] Figure 10 is a top sectional view of the lens system.

[0020] Figure 11 is a second perspective view of the lens system.

[0021] Figure 12 is a third perspective view of the lens system.

[0022] Figure 13 is a side view of the lens system in the unaccommodated state.

[0023] Figure 14 is a side sectional view of the lens system in the unaccommodated state.

[0024] Figure 15 is a top sectional view of the lens system in the unaccommodated state.

[0025] Figure 16 is a sectional view of the human eye with the lens system implanted in the capsular bag and the lens system in the accommodated state.

[0026] Figure 17 is a sectional view of the human eye with the lens system implanted in the capsular bag and the lens system in the unaccommodated state.

[0027] Figure 17A is a sectional view of an arm of the lens system.

[0028] Figure 17B is a sectional view of another embodiment of the arm of the lens system.

[0029] Figures 17C-17L are sectional views of other embodiments of the arm of the lens system.

[0030] Figure 17M is a side sectional view of another embodiment of the lens system.

[0031] Figure 17N is a side sectional view of another embodiment of the lens system.

[0032] Figure 17P is a perspective view of another embodiment of the lens system.

[0033] Figure 18 is a partial top sectional view of another embodiment of the lens system, implanted in the capsular bag.

[0034] Figure 19 is a partial side sectional view of another embodiment of the lens system, implanted in the capsular bag.

[0035] Figure 20 is a side view of a stop member system employed in one embodiment of the lens system.

[0036] Figure 21 is a side elevation view of another embodiment of the lens system with a number of separation members.

[0037] Figure 22 is a front elevation view of the lens system of Figure 21.

[0038] Figure 23 is an overhead sectional view of the lens system of Figure 21.

[0039] Figure 24 is an overhead sectional view of the lens system of Figure 21, with the viewing elements at a minimum separation distance.

[0040] Figure 25 is a close-up view of the contact between a separation member and an opposing surface.

[0041] Figure 26 is a front view of another embodiment of the lens system.

[0042] Figure 27 is a side sectional view of the lens system of Figure 26.

[0043] Figure 28 is a top sectional view of the lens system of Figure 26.

[0044] Figure 29 is a front view of another embodiment of the lens system.

[0045] Figure 30 is a side sectional view of the lens system of Figure 29.

[0046] Figure 31 is a top sectional view of the lens system of Figure 29.

[0047] Figure 32 is a front view of another embodiment of the lens system.

[0048] Figure 33 is a side sectional view of the lens system of Figure 32.

[0049] Figure 34 is a top sectional view of the lens system of Figure 32.

[0050] Figure 35 is a perspective view of the lens system of Figure 32.

[0051] Figure 36 is a top sectional view of the lens system of Figure 32, implanted in a capsular bag.

[0052] Figure 37 is a side sectional view of the lens system of Figure 32, implanted in a capsular bag.

[0053] Figure 38 is top view of another embodiment of an intraocular lens system.

[0054] Figure 39 is a sectional view of the lens system of Figure 38, with a first viewing element in a first position relative to a second viewing element.

[0055] Figure 40 is a sectional view of the lens system of Figure 38, with the first viewing element in a second position relative to the second viewing element.

[0056] Figure 41 is a side sectional view of the lens system of Figure 3, illustrating optical axes of the anterior and posterior viewing elements.

[0057] Figure 42 is a side sectional view of the lens system of Figure 41, with the anterior viewing element tilted with respect to the posterior viewing element.

[0058] Figure 43 is a schematic view of the viewing elements of the lens system of Figure 41, prior to a decentration movement of the viewing elements.

[0059] Figure 44 is a schematic view of the viewing elements of the lens system of Figure 41, after the viewing elements have decentered relative to each other.

[0060] Figure 45 is a perspective view of a method of measuring an aberration-inducing force characteristic.

#### Detailed Description of Preferred Embodiments

### I. THE HUMAN EYE AND ACCOMMODATION

[0061] Figures 1 and 2 show the human eye 50 in section. Of particular relevance to the present disclosure are the cornea 52, the iris 54 and the lens 56, which is situated within the elastic, membranous capsular bag or lens capsule 58. The capsular bag 58 is surrounded by and suspended within the ciliary muscle 60 by ligament-like structures called zonules 62.

[0062] As light enters the eye 50, the cornea 52 and the lens 56 cooperate to focus the incoming light and form an image on the retina 64 at the rear of the eye, thus facilitating vision. In the process known as accommodation, the shape of the lens 56 is altered (and its refractive properties thereby adjusted) to allow the eye 50 to focus on objects at varying distances. A typical healthy eye has sufficient accommodation to enable focused vision of objects ranging in distance from infinity (generally defined as over 20 feet from the eye) to very near (closer than 10 inches).



[0063] The lens 56 has a natural elasticity, and in its relaxed state assumes a shape that in cross-section resembles a football. Accommodation occurs when the ciliary muscle 60 moves the lens from its relaxed or “unaccommodated” state (shown in Figure 1) to a contracted or “accommodated” state (shown in Figure 2). Movement of the ciliary muscle 60 to the relaxed/unaccommodated state increases tension in the zonules 62 and capsular bag 58, which in turn causes the lens 56 to take on a thinner (as measured along the optical axis) or taller shape as shown in Figure 1. In contrast, when the ciliary muscle 60 is in the contracted/accommodated state, tension in the zonules 62 and capsular bag 58 is decreased and the lens 56 takes on the fatter or shorter shape shown in Figure 2. When the ciliary muscles 60 contract and the capsular bag 58 and zonules 62 slacken, some degree of tension is maintained in the capsular bag 58 and zonules 62.

## II. THE LENS SYSTEM: STRUCTURE

[0064] Figures 3-17 depict one embodiment of an intraocular lens system 100 which is configured for implantation into the capsular bag 58 in place of the natural lens 56, and is further configured to change the refractive properties of the eye in response to the eye’s natural process of accommodation. With reference to Figure 3, a set of axes is included to illustrate the sense of directional terminology which will be used herein to describe various features of the lens system 100. The terms “anterior” and “posterior” refer to the depicted directions on the optical axis of the lens 100 shown in Figure 3. When the lens 100 is implanted in an eye, the anterior direction extends toward the cornea and the posterior direction extends toward the retina, with the optical axis of the lens substantially coincident with the optical axis of the eye shown in Figures 1 and 2. The terms “left” and “right” refer to the directions shown on the lateral axis, which is orthogonal to the optical axis. In addition, the terms “upper” and “lower” refer to the directions depicted on the transverse axis which is orthogonal to both of the optical axis and the lateral axis.

[0065] This system of axes is depicted purely to facilitate description herein; thus, it is not intended to limit the possible orientations which the lens system 100 may assume during use. For example, the lens system 100 may rotate about, or may be displaced along, the optical axis during use without detracting from the performance of the lens. It is clear that, should the lens system 100 be so rotated about the optical axis, the transverse axis may no longer have an upper-lower orientation and the lateral axis may no longer have a left-right orientation, but the lens system 100 will continue to function as

it would when oriented as depicted in Figure 3. Accordingly, when the terms “upper,” “lower,” “left” or “right” are used in describing features of the lens system 100, such use should not be understood to require the described feature to occupy the indicated position at any or all times during use of the lens system 100. Similarly, such use should not be understood to require the lens system 100 to maintain the indicated orientation at any or all times during use.

[0066] As best seen in Figure 4, the lens system 100 has an anterior portion 102 which is anterior or forward of the line A-A (which represents a plane substantially orthogonal to the optical axis and intersecting first and second apices 112, 116) and a posterior portion 104 which is posterior or rearward of the line A-A. The anterior portion 102 comprises an anterior viewing element 106 and an anterior biasing element 108. The anterior biasing element 108 in turn comprises a first anterior translation member 110 which extends from the anterior viewing element 106 to the first apex 112 and a second anterior translation member 114 which extends from the anterior viewing element 106 to the second apex 116. In the illustrated embodiment the first anterior translation member 110 comprises a right arm 110a and a left arm 110b (see Figure 3). In addition, the depicted second anterior translation member 114 comprises a right arm 114a and a left arm 114b. However, in other embodiments either or both of the first and second anterior translation members 110, 114 may comprise a single arm or member, or more than two arms or members.

[0067] As best seen in Figures 4, 5 and 7, the posterior portion 104 includes a posterior viewing element 118 and a posterior biasing element 120. The posterior biasing element 120 includes a first posterior translation member 122 extending from the posterior viewing element 118 to the first apex 112 and a second posterior translation member 124 extending from the posterior viewing element 118 to the second apex 116. In the illustrated embodiment, the first posterior translation member comprises a right arm 122a and a left arm 122b. Likewise, the depicted second posterior translation member 124 comprises a right arm 124a and a left arm 124b. However, in other embodiments either or both of the first and second posterior translation members 122, 124 may comprise a single arm or member, or more than two arms or members.

[0068] In the embodiment shown in Figure 4, the anterior biasing element 108 and the posterior biasing element are configured symmetrically with respect to the plane A-A as the lens system 100 is viewed from the side. As used herein to describe the

biasing elements 108, 120, “symmetric” or “symmetrically” means that, as the lens system 100 is viewed from the side, the first anterior translation member 110 and the first posterior translation member 122 extend from the first apex 112 at substantially equal first anterior and posterior biasing angles  $\theta_1$ ,  $\theta_2$  with respect to the line A-A (which, again, represents the edge of a plane which is substantially orthogonal to the optical axis and intersects the first and second apices 112, 116) and/or that the second anterior translation member 114 and the second posterior translation member 124 extend from the second apex 116 at substantially equal second anterior and posterior biasing angles  $\theta_3$ ,  $\theta_4$  with respect to the line A-A. Alternative or asymmetric configurations of the biasing elements are also possible. It should be further noted that a symmetric configuration of the biasing elements 108, 120 does not dictate symmetric positioning of the viewing elements with respect to the line A-A; in the embodiment shown in Figure 4 the anterior viewing element 106 is closer to the line A-A than is the posterior viewing element.

[0069] Preferably, both the anterior viewing element 106 and the posterior viewing element 118 comprise an optic or lens having refractive power. (As used herein, the term “refractive” or “refractive power” shall include “diffractive” or “diffractive power”.) Some preferred power ranges for the optics are discussed in detail below. In alternative embodiments one or both of the anterior and posterior viewing elements 106, 118 may comprise an optic with a surrounding or partially surrounding perimeter frame member or members, with some or all of the biasing elements/translation members attached to the frame member(s). As a further alternative, one of the viewing elements 106, 118 may comprise a perimeter frame with an open/empty central portion or void located on the optical axis, or a perimeter frame member or members with a zero-power lens or transparent member therein. In still further variations, one of the viewing elements 106, 118 may comprise only a zero-power lens or transparent member.

[0070] In one embodiment (see Figs. 12, 19), a retention portion 126 is coupled to the anterior portion 102, preferably at the anterior viewing element 106. The retention portion 126 preferably includes a first retention member 128 and a second retention member 130, although in alternative embodiments the retention portion 126 may be omitted altogether, or may comprise only one retention member or more than two retention members. The first retention member 128 is coupled to the anterior viewing element 106 at a fixed end 128a and also includes a free end 128b opposite the fixed end 128a. Likewise, the second retention member 130 includes a fixed end 130a and a free

end 130b. The retention members 128, 130 are illustrated as being coupled to the anterior viewing element 106 at the upper and lower edges thereof; however, the retention members 128, 130 may alternatively be attached to the anterior viewing element 106 at other suitable edge locations.

[0071] In one embodiment (see Figs. 3, 5, 7-8, 18), the posterior portion 104 includes a distending portion 132, preferably attached to the posterior viewing element 118. A preferred distending portion 132 includes a first distending member 134 which in turn includes a fixed end 134a, a free end 134b opposite the fixed end 134a and preferably also includes an opening 134c formed therein. One preferred distending portion 132 also comprises a second distending member 136 with a fixed end 136a, a free end 136b and preferably an opening 136c formed therein. In alternative embodiments, the distending portion 132 may be omitted altogether, or may comprise a single distending member or more than two distending members. To optimize their effectiveness, a preferred location for the distending members 134, 136 is 90 degrees away (about the optical axis) from the apices 112, 116 on the posterior portion 104. Where the biasing elements form more than two apices (or where two apices are not spaced 180 degrees apart about the optical axis), one or more distending members may be positioned angularly midway between the apices about the optical axis. Alternatively, the distending member(s) may occupy other suitable positions relative to the apices (besides the "angularly midway" positions disclosed above); as further alternatives, the distending member(s) may be located on the anterior portion 102 of the lens system 100, or even on the apices themselves. The functions of the retention portion 126 and the distending portion 132 will be described in greater detail below.

### **III. THE LENS SYSTEM: FUNCTION/OPTICS**

[0072] The anterior and posterior biasing elements 108, 120 function in a spring-like manner to permit the anterior viewing element 106 and posterior viewing element 118 to move relative to each other generally along the optical axis. The biasing elements 108, 120 bias the viewing elements 106, 118 apart so that the elements 106, 108 separate to the accommodated position or accommodated state shown in Figure 4. Thus, in the absence of any external forces, the viewing elements are at their maximum separation along the optical axis. The viewing elements 106, 118 of the lens system 100 may be moved toward each other, in response to a ciliary muscle force of up to 2 grams,

to provide an unaccommodated position by applying appropriate forces upon the anterior and posterior portions 102, 104 and/or the apices 112, 116.

[0073] When the lens system 100 is implanted in the capsular bag 58 (Figures 16-17) the above described biasing forces cause the lens system 100 to expand along the optical axis so as to interact with both the posterior and anterior aspects of the capsular bag. Such interaction preferably occurs throughout the entire range of motion of the ciliary muscle 60. At one extreme the ciliary muscle is relaxed and the zonules 62 pull the capsular bag 58 radially so as to cause the bag to become more disk shaped. The anterior and posterior sides of the bag, in turn, apply force to the anterior and posterior portions 102, 104 of the lens system 100, thereby forcing the viewing elements 106, 118 toward each other into the unaccommodated position. At the other extreme, the ciliary muscle contracts and the zonules 62 move inwardly to provide slack in the capsular bag 58 and allow the bag to become more football-shaped. The slack in the bag is taken up by the lens system due to the biasing-apart of the anterior and posterior viewing elements 106, 118. As the radial tension in the bag is reduced, the viewing elements 106, 118 move away from each other into an accommodated position. Thus, the distance between the viewing elements 106, 118 depends on the degree of contraction or relaxation of the ciliary muscle 60. As the distance between the anterior and posterior viewing elements 106, 118 is varied, the focal length of the lens system 100 changes accordingly. Thus, when the lens system 100 is implanted into the capsular bag (see Figures 16-17) the lens system 100 operates in conjunction with the natural accommodation processes of the eye to move between the accommodated (Figure 16) and unaccommodated (Figure 17) states in the same manner as would a healthy "natural" lens. Preferably, the lens system 100 can move between the accommodated and unaccommodated states in less than about one second.

[0074] The entire lens system 100, other than the optic(s), thus can comprise an articulated frame whose functions include holding the optic(s) in position within the capsular bag and guiding and causing movement of the optic(s) between the accommodated and unaccommodated positions.

[0075] Advantageously, the entire lens system 100 may comprise a single piece of material, i.e. one that is formed without need to assemble two or more components by gluing, heat bonding, the use of fasteners or interlocking elements, etc. This characteristic increases the reliability of the lens system 100 by improving its

resistance to material fatigue effects which can arise as the lens system experiences millions of accommodation cycles throughout its service life.

[0076] In those embodiments where the optic(s) are installed into annular or other perimeter frame member(s) (see discussion below), the articulated frame may comprise a single piece of material, to obtain the performance advantages discussed above. It is believed that the assembly of the optic(s) to the articulated frame will not substantially detract from the achievement of these advantages.

[0077] The lens system 100 has sufficient dynamic range that the anterior and posterior viewing elements 106, 118 move about 0.5-4 mm, preferably about 1-3 mm, more preferably about 1-2 mm, and most preferably about 1.5 mm closer together when the lens system 100 moves from the accommodated state to the unaccommodated state. In other words the separation distance X (see Figures 9-10, 14-15) between the anterior and posterior viewing elements 106, 118, which distance may for present purposes be defined as the distance along the optical axis (or a parallel axis) between a point of axial intersection with the posterior face of the anterior viewing element 106 and a point of axial intersection with the anterior face of the posterior viewing element 118, decreases by the amount(s) disclosed above upon movement of the lens system 100 to the unaccommodated state. Simultaneously, in one preferred mode the total system thickness Y decreases from about 3.0 - 4.0 mm in the accommodated state to about 1.5 - 2.5 mm in the unaccommodated state.

[0078] As may be best seen in Figure 6, the first anterior translation member 110 connects to the anterior viewing element 106 via connection of the left and right arms 110a, 110b to first and second transition members 138, 140 at attachment locations 142, 144. The second anterior translation member 114 connects to the anterior viewing element 106 via connection of left and right arms 114a, 114b to the first and second transition members 138, 140 at attachment locations 146, 148. This is a presently preferred arrangement for the first and second anterior translation members 110, 114; alternatively, the first and second anterior translation members 110, 114 could be connected directly to the anterior viewing element 106, as is the case with the connection of the first and second posterior translation members 122, 124 to the posterior viewing element 118.

[0079] However the connection is established between the first and second anterior translation members 110, 114 and the anterior viewing element 106, it is

preferred that the attachment locations 142, 144 corresponding to the first anterior translation member 110 be farther away from the first apex 112 than is the closest edge or the periphery of the anterior viewing element 106. This configuration increases the effective length of the first anterior translation member 110/arms 110a, 110b, in comparison to a direct or straight attachment between the apex 112 and the nearest/top edge of the anterior viewing element 106. For the same reasons, it is preferred that the attachment locations 146, 148 associated with the second anterior translation member 114 be farther away from the second apex 116 than is the closest/bottom edge of the anterior viewing element 106.

[0080] As best seen in Figure 7, the first posterior translation member 122 is preferably connected directly to the posterior viewing element 118 via attachment of the left and right arms 122a, 122b to the element 118 at attachment points 150, 152. Likewise, the second posterior translation member 124 is preferably directly connected to the posterior viewing element 118 via connection of the left and right arms 124a, 124b to the element 118 at attachment points 154, 156, respectively. In alternative embodiments, the first and second posterior translation members 124, 122 can be connected to the posterior viewing element via intervening members as is done with the anterior viewing element 106. No matter how these connections are made, it is preferred that the attachment locations 150, 152 be spaced further away from the first apex 112 than is the nearest edge or the periphery of the posterior viewing element 118. Similarly, it is preferred that the attachment locations 154, 156 be spaced further away from the second apex 116 than is the closest edge of the posterior viewing element 118.

[0081] By increasing the effective length of some or all of the translation members 110, 114, 122, 124 (and that of the arms 110a, 110b, 114a, 114b, 122a, 122b, 124a, 124b where such structure is employed), one preferred configuration of the attachment locations 142, 144, 146, 148, 150, 152, 154, 156 relative to the first and second apices 112, 116 enables the anterior and/or posterior viewing elements 106, 118 to move with respect to one another a greater distance along the optical axis, for a given angular displacement of the anterior and/or posterior translation members. This arrangement thus facilitates a more responsive spring system for the lens system 100 and minimizes material fatigue effects associated with prolonged exposure to repeated flexing.

[0082] In the illustrated embodiment, the attachment location 142 of the first anterior translation member 110 is spaced from the corresponding attachment location

146 of the second anterior translation member 114 along the periphery of the anterior viewing element, and the same relationship exists between the other pairs of attachment locations 144, 148; 150, 154; and 152, 156.

**[0083]** It is also preferred that the attachment locations 142, 144 of the first anterior translation member 110 be located equidistant from the first apex 112, and that the right and left arms 110a, 110b of the member 110 be equal in length. Furthermore, the arrangement of the attachment locations 146, 148, arms 114a, 114b and second apex preferably mirrors that recited above regarding the first anterior translation member 110, while the apices 112, 116 are preferably equidistant from the optical axis and are situated 180 degrees apart.

**[0084]** A like combination of equidistance and equal length is preferred for the first and second posterior translation members 122, 124 and their constituent arms 122a, 122b, 124a, 124b and attachment points 150, 152, 154, 156, with respect to the apices 112, 116. However, as shown the arms 122a, 122b, 124a, 124b need not be equal in length to their counterparts 110a, 110b, 114a, 114b in the first and second anterior translation members 110, 114.

**[0085]** Where any member or element connects to the periphery of the anterior or posterior viewing elements 106, 118, the member defines a connection geometry or attachment area with a connection width  $W$  and a connection thickness  $T$  (see Figure 4 and the example illustrated therein, of the connection of the second posterior translation member 124 to the posterior viewing element 118). For purposes of clarity, the connection width is defined as being measured along a direction substantially parallel to the periphery of the viewing element in question, and the connection thickness is defined as measured along a direction substantially perpendicular to the periphery of the viewing element. (The periphery itself is deemed to be oriented generally perpendicular to the optical axis as shown in Figure 4.) Preferably, no attachment area employed in the lens system 100 has a ratio of width to thickness less than 3. It has been found that such a geometry reduces distortion of the viewing element/optic due to localized forces. For the same reasons, it is also preferred that each of the translation members 110, 114, 122, 124 be connected to the periphery of the respective viewing elements at two or more attachment areas, each having a preferred geometry discussed above.

**[0086]** Figures 17A and 17B show two preferred cross-sectional configurations which may be used along some or all of the length of the translation



members and/or arms 110a, 110b, 114a, 114b, 122a, 122b, 124a, 124b. The shape is defined by a relatively broad and flat or slightly curved outer surface 182. It is intended that when in use the outer surface faces away from the interior of the lens system and/or toward the capsular bag 58. The remaining surfaces, proportions and dimensions making up the cross-sectional shape can vary widely but may advantageously be selected to facilitate manufacture of the lens system 100 via molding or casting techniques while minimizing stresses in the arms during use of the lens system.

[0087] Figures 17C-17L depict a number of alternative cross-sectional configurations which are suitable for the translation members and/or arms 110a, 110b, 114a, 114b, 122a, 122b, 124a, 124b. As shown, a wide variety of cross-sectional shapes may be used, but preferably any shape includes the relatively broad and flat or slightly curved outer surface 182.

[0088] It is further contemplated that the dimensions, shapes, and/or proportions of the cross-sectional configuration of the translation members and/or arms 110a, 110b, 114a, 114b, 122a, 122b, 124a, 124b may vary along the length of the members/arms. This may be done in order to, for example, add strength to high-stress regions of the arms, fine-tune their spring characteristics, add rigidity or flexibility, etc.

[0089] As discussed above, each of the anterior viewing element 106 and the posterior viewing element 118 preferably comprises an optic having refractive power. In one preferred embodiment, the anterior viewing element 106 comprises a biconvex lens having positive refractive power and the posterior viewing element 118 comprises a convexo-concave lens having negative refractive power. The anterior viewing element 106 may comprise a lens having a positive power advantageously less than 55 diopters, preferably less than 40 diopters, more preferably less than 35 diopters, and most preferably less than 30 diopters. The posterior viewing element 118 may comprise a lens having a power which is advantageously between -25 and 0 diopters, and preferably between -25 and -15 diopters. In other embodiments, the posterior viewing element 118 comprises a lens having a power which is between -15 and 0 diopters, preferably between -13 and -2 diopters, and most preferably between -10 and -5 diopters. Advantageously, the total power of the optic(s) employed in the lens system 100 is about 5-35 diopters; preferably, the total power is about 10-30 diopters; most preferably, the total power is about 15-25 diopters. (As used herein, the term "diopter" refers to lens or system power as measured when the lens system 100 has been implanted in the human eye in the usual

manner.) It should be noted that if materials having a high index of refraction (e.g., higher than that of silicone) are used, the optics may be made thinner which facilitates a wider range of motion for the optics. This in turn allows the use of lower-power optics than those specified above. In addition, higher-index materials allow the manufacture of a higher-power lens for a given lens thickness and thereby reduce the range of motion needed to achieve a given range of accommodation.

[0090] Some lens powers and radii of curvature presently preferred for use with an embodiment of the lens system 100 with optic(s) having a refractive index of about 1.432 are as follows: a +31 diopter, biconvex lens with an anterior radius of curvature of 5.944 mm and a posterior radius of curvature of 5.944 mm; a +28 diopter, biconvex lens with an anterior radius of curvature of 5.656 mm and a posterior radius of curvature of 7.788 mm; a +24 diopter, biconvex lens with an anterior radius of curvature of 6.961 mm and a posterior radius of curvature of 8.5 mm; a -10 diopter, biconcave lens with an anterior radius of curvature of 18.765 mm and a posterior radius of curvature of 18.765 mm; a -8 diopter, concavo-convex lens with an anterior radius of curvature of between 9 mm and 9.534 mm and a posterior radius of curvature of 40 mm; and a -5 diopter, concavo-convex lens with an anterior radius of curvature of between 9 mm and 9.534 mm and a posterior radius of curvature of 20 mm. In one embodiment, the anterior viewing element comprises the +31 diopter lens described above and the posterior viewing element comprises the -10 diopter lens described above. In another embodiment, the anterior viewing element comprises the +28 diopter lens described above and the posterior viewing element comprises the -8 diopter lens described above. In another embodiment, the anterior viewing element comprises the +24 diopter lens described above and the posterior viewing element comprises the -5 diopter lens described above.

[0091] The combinations of lens powers and radii of curvature specified herein advantageously minimize image magnification. However, other designs and radii of curvature provide modified magnification when desirable.

[0092] The lenses of the anterior viewing element 106 and the posterior viewing element 118 are relatively moveable as discussed above; advantageously, this movement is sufficient to produce an accommodation of at least one diopter, preferably at least two diopters and most preferably at least three diopters. In other words, the movement of the optics relative to each other and/or to the cornea is sufficient to create a difference between (i) the refractive power of the user's eye in the accommodated state

and (ii) the refractive power of the user's eye in the unaccommodated state, having a magnitude expressed in diopters as specified above. Where the lens system 100 has a single optic, the movement of the optic relative to the cornea is sufficient to create a difference in focal power as specified above.

[0093] Advantageously, the lens system 100 can be customized for an individual patient's needs by shaping or adjusting only one of the four lens faces, and thereby altering the overall optical characteristics of the system 100. This in turn facilitates easy manufacture and maintenance of an inventory of lens systems with lens powers which will fit a large population of patients, without necessitating complex adjustment procedures at the time of implantation. It is contemplated that all of the lens systems in the inventory have a standard combination of lens powers, and that a system is fitted to a particular patient by simply shaping only a designated "variable" lens face. This custom-shaping procedure can be performed to-order at a central manufacturing facility or laboratory, or by a physician consulting with an individual patient. In one embodiment, the anterior face of the anterior viewing element is the designated sole variable lens face. In another embodiment, the anterior face of the posterior viewing element is the only variable face. However, any of the lens faces is suitable for such designation. The result is minimal inventory burden with respect to lens power (all of the lens systems in stock have the same lens powers) without requiring complex adjustment for individual patients (only one of the four lens faces is adjusted in the fitting process).

#### **IV. THE LENS SYSTEM: ALTERNATIVE EMBODIMENTS**

[0094] Figures 17M and 17N depict another embodiment 250 of the intraocular lens. It is contemplated that, except as noted below, this embodiment 250 is largely similar to the embodiment disclosed in Figures 3-17. The lens 250 features an anterior biasing element 108 and posterior biasing element 120 which are arranged asymmetrically as the lens system 100 is viewed from the side. As used herein to describe the biasing elements 108, 120, "asymmetric" or "asymmetrically" means that, as the lens system 100 is viewed from the side, the first anterior translation member 110 and the first posterior translation member 122 extend from the first apex 112 at unequal first anterior and posterior biasing angles  $\delta_1$ ,  $\delta_2$  with respect to the line B-B (which represents the edge of a plane which is substantially orthogonal to the optical axis and intersects the first and second apices 112, 116) and/or that the second anterior translation member 114 and the

second posterior translation member 124 extend from the second apex 116 at substantially equal second anterior and posterior biasing angles  $\delta_3$ ,  $\delta_4$  with respect to the line B-B.

[0095] In the embodiment shown in Figures 17M-17N, the first and second anterior biasing angles  $\delta_1$ ,  $\delta_3$  are greater than the corresponding first and second posterior biasing angles  $\delta_2$ ,  $\delta_4$ . This arrangement advantageously maintains the posterior viewing element 118 and apices 112, 116 in a substantially stationary position. Consequently, the moving mass of the lens system 250 is reduced, and the anterior viewing element 106 can move more quickly over a wider range along the optical axis under a given motive force. (Note that even where the posterior biasing element 120 and its constituent first and second posterior translation members 122, 124 are substantially immobile, they are nonetheless “biasing elements” and “translation members” as those terms are used herein.) In another embodiment, the anterior biasing element 108 and posterior biasing element 120 are arranged asymmetrically in the opposite direction, i.e. such that the first and second anterior biasing angles  $\delta_1$ ,  $\delta_3$  are smaller than the corresponding first and second posterior biasing angles  $\delta_2$ ,  $\delta_4$ . This arrangement also provides for a wider range of relative movement of the viewing elements, in comparison to a “symmetric” system.

[0096] It should be further noted that the viewing elements 106, 118 shown in Figures 17M-17N are asymmetrically positioned in that the posterior viewing element 118 is closer to the line B-B than is the anterior viewing element 106. It has been found that this configuration yields desirable performance characteristics irrespective of the configuration of the biasing elements 108, 120. In alternative embodiments, the viewing elements 106, 118 may be positioned symmetrically with respect to the line B-B, or they may be positioned asymmetrically with the anterior viewing element 106 closer to the line B-B than the posterior viewing element 118 (see Figure 4 wherein the line in question is denoted A-A). Furthermore, the symmetry or asymmetry of the biasing elements and viewing elements can be selected independently of each other.

[0097] Figure 17P shows another embodiment 350 of an intraocular lens in which the posterior viewing element 118 comprises an annular frame member defining a void therein, while the anterior viewing element 106 comprises an optic having refractive power. Alternatively, the posterior viewing element 118 could comprise a zero power lens or a simple transparent member. Likewise, in another embodiment the anterior viewing element 106 could comprise an annular frame member with a void therein or a simple zero power lens or transparent member, with the posterior viewing element 118

comprising an optic having refractive power. As a further alternative, one or both of the anterior and posterior viewing elements 106, 118 may comprise an annular or other perimeter frame member which can receive a removable optic (or a "one-time install" optic) with an interference type fit and/or subsequent adhesive or welding connections. Such a configuration facilitates assembly and/or fine-tuning of the lens system during an implantation procedure, as will be discussed in further detail below.

#### **V. THE LENS SYSTEM: DISTENDING PORTION**

[0098] Figure 18 depicts the function of the distending portion 132 in greater detail. The lens system 100 is shown situated in the capsular bag 58 in the customary manner with the anterior viewing element 106 and posterior viewing element 118 arranged along the optical axis. The capsular bag 58 is shown with a generally circular anterior opening 66 which may often be cut into the capsular bag during installation of the lens system 100. The first and second distending members 134, 136 of the distending portion 132 distend the capsular bag 58 so that intimate contact is created between the posterior face of the posterior viewing element and/or the posterior biasing element 120. In addition, intimate contact is facilitated between the anterior face of the anterior viewing element 106 and/or anterior biasing element 108. The distending members 134, 136 thus remove slack from the capsular bag 58 and ensure optimum force coupling between the bag 58 and the lens system 100 as the bag 58 is alternately stretched and released by the action of the ciliary muscle.

[0099] Furthermore, the distending members 134, 136 reshape the capsular bag 58 into a taller, thinner configuration along its range of accommodation to provide a wider range of relative motion of the viewing elements 106, 118. When the capsular bag 58 is in the unaccommodated state, the distending members 134, 136 force the capsular bag into a thinner configuration (as measured along the optical axis) in comparison to the unaccommodated configuration of the capsular bag 58 with the natural lens in place. Preferably, the distending members 134, 136 cause the capsular bag 58 to take on a shape in the unaccommodated state which is about 1.0-2.0 mm thinner, more preferably about 1.5 mm thinner, along the optical axis than it is with the natural lens in place and in the unaccommodated state.

[0100] With such a thin "starting point" provided by the distending members 134, 136, the viewing elements 106, 118 of the lens system can move a greater distance apart, and provide a greater range of accommodation, without causing undesirable contact

between the lens system and the iris. Accordingly, by reshaping the bag as discussed above the distending members 134, 136 facilitate a range of relative motion of the anterior and posterior viewing elements 106, 118 of about 0.5-4 mm, preferably about 1-3 mm, more preferably about 1-2 mm, and most preferably about 1.5 mm.

[0101] The distending portion 132/distending members 134, 136 are preferably separate from the anterior and posterior biasing elements 108, 120; the distending members 134, 136 thus preferably play no part in biasing the anterior and posterior viewing elements 106, 118 apart toward the accommodated position. This arrangement is advantageous because the apices 112, 116 of the biasing elements 108, 120 reach their point of minimum protrusion from the optical axis (and thus the biasing elements reach their minimum potential effectiveness for radially distending the capsular bag) when the lens system 100 is in the accommodated state (see Figure 16), which is precisely when the need is greatest for a taut capsular bag so as to provide immediate response to relaxation of the ciliary muscles. One preferred distending portion is "static" (as opposed to the "dynamic" biasing members 108, 120 which move while urging the viewing elements 106, 118 to the accommodated position or carrying the viewing elements to the unaccommodated position) in that its member(s) protrude a substantially constant distance from the optical axis throughout the range of motion of the viewing elements 106, 118. Although some degree of flexing may be observed in the distending members 134, 136, they are most effective when rigid. Furthermore, the thickness and/or cross-sectional profile of the distending members 134, 136 may be varied over the length of the members as desired to provide a desired degree of rigidity thereto.

[0102] The distending portion 132, distending members 134, 136 advantageously reshape the capsular bag 58 by stretching the bag 58 radially away from the optical axis and causing the bag 58 to take on a thinner, taller shape throughout the range of accommodation by the eye. This reshaping is believed to facilitate a broad (as specified above) range of relative motion for the viewing elements of the lens system 100, with appropriate endpoints (derived from the total system thicknesses detailed above) to avoid the need for unacceptably thick optic(s) in the lens system.

[0103] If desired, the distending members 134, 136 may also function as haptics to stabilize and fixate the orientation of the lens system 100 within the capsular bag. The openings 134c, 136c of preferred distending members 134, 136 permit cellular ingrowth from the capsular bag upon positioning of the lens system 100 therein. Finally,

other methodologies, such as a separate capsular tension ring or the use of adhesives to glue the capsular bag together in selected regions, may be used instead of or in addition to the distending portion 132, to reduce "slack" in the capsular bag.

[0104] A tension ring can also be employed with the lens system 100, to act as a physical barrier to cell growth on the inner surface of the capsular bag. Thus, the tension ring can provide additional benefits in limiting posterior capsule opacification, by preventing cellular growth from advancing posteriorly on the inner surface of the bag. When implanted, the tension ring firmly contacts the inner surface of the bag and defines a circumferential barrier against cell growth on the inner surface from one side of the barrier to another.

[0105] Figure 19 shows the function of the retention portion 126 in greater detail. It is readily seen that the first and second retention members 128, 130 facilitate a broad contact base between the anterior portion of the lens system 100 and the anterior aspect of the capsular bag 58. By appropriately spacing the first and second retention members 128, 130, the members prevent extrusion of the anterior viewing element 106 through the anterior opening 66. It is also readily seen that where contact occurs between the anterior aspect of the capsular bag 58 and one or both of the retention members 128, 130, the retention members also participate in force coupling between the bag 58 and the lens system 100 as the bag is stretched and released by the action of the ciliary muscles.

[0106] As best seen in Figures 18 and 19, the anterior portion 102 of the lens system 100 forms a number of regions of contact with the capsular bag 58, around the perimeter of the anterior viewing element 106. In the illustrated embodiment, at least some of these regions of contact are located on the anteriormost portions of the anterior biasing element 108, specifically at the transition members 138, 140, and at the retention members 128, 130. The transition members and the retention members define spaces therebetween at the edges of the anterior viewing element 106 to permit fluid to flow between the interior of the capsular bag 58 and the portions of the eye anterior of the bag 58. In other words, the anterior portion of the lens system 100 includes at least one location which is spaced from and out of contact with the capsular bag 58 to provide a fluid flow channel extending from the region between the viewing elements 106, 118 to the exterior of the bag 58. Otherwise, if the anterior portion 102 of the lens system 100 seals the anterior opening 66 of the bag 58, the resulting prevention of fluid flow can cause the aqueous humor in the capsular bag to stagnate, leading to a clinically adverse

event, and can inhibit the movement of the lens system 100 between the accommodated and unaccommodated states.

[0107] If desired, one or both of the retention members 128, 130 may have an opening 129 formed therein to permit fluid flow as discussed above.

[0108] The retention members 128, 130 and the transition members 138, 140 also prevent contact between the iris and the anterior viewing element 106, by separating the anterior opening 66 from the anterior face of the viewing element 106. In other words, the retention members 128, 130 and the transition members 138, 140 displace the anterior aspect of the capsular bag 58, including the anterior opening 66, anteriorly from the anterior viewing element 106, and maintain this separation throughout the range of accommodation of the lens system. Thus, if contact occurs between the iris and the lens system-capsular bag assembly, no part of the lens system will touch the iris, only the capsular bag itself, in particular those portions of the bag 58 overlying the retention members 128, 130 and/or the transition members 138, 140. The retention members 128, 130 and/or the transition members 138, 140 therefore maintain a separation between the iris and the lens system, which can be clinically adverse if the contacting portion(s) of the lens system are constructed from silicone.

#### **VI. THE LENS SYSTEM: STOP MEMBERS**

[0109] As depicted in Figure 20, one or more stop members or separation members 190 may be located where appropriate on the anterior and/or posterior biasing elements 108, 120 to limit the convergent motion of the anterior and posterior viewing elements 106, 118, and preferably prevent contact therebetween. As the lens system 100 moves toward the unaccommodated position, the stop member(s) located on the anterior biasing element 108 come into contact with the posterior biasing element 120 (or with additional stop member(s) located thereon), and any stop member(s) located on the posterior biasing element 120 come into contact with the anterior biasing element 108 (or with additional stop member(s) located thereon). The stop members 190 thus define a point or state of maximum convergence (in other words, the unaccommodated state) of the lens system 100, viewing elements 106, 118. Such definition advantageously assists in setting one extreme of the range of focal lengths which the lens system may take on (in those lens systems which include two or more viewing elements having refractive power) and/or one extreme of the range of motion of the lens system 100.



[0110] The stop members 190 shown in Figure 20 are located on the first and second anterior translation members 110, 114 of the anterior biasing element 108 and extend posteriorly therefrom. When the anterior and posterior viewing elements 106, 118 move together, one or more of the stop members 190 will contact the posterior translation member(s) 122, 124, thereby preventing further convergent motion of the viewing elements 106, 118. Of course, in other embodiments the stop member(s) 190 can be in any suitable location on the lens system 100.

[0111] Figures 21-25 depict another embodiment of the lens system 100 having a number of stop members or separation members 190. In this embodiment the stop members 190 include posts 190a and tabs 190b, although it will be apparent that any number or combination of suitable shapes may be employed for the stop members 190. Each of the stop members 190 has at least one contact surface 191, one or more of which abuts an opposing surface of the lens system 100 when the anterior and posterior viewing elements 106, 118 converge to a minimum separation distance SD (see Figure 24). In the embodiment shown, one or more of the contact surfaces 191 of the posts 190a are configured to abut an opposing surface defined by a substantially flat anterior perimeter portion 193 of the posterior viewing element 118, when the viewing elements 106, 118 are at the minimum separation distance SD. One or more of the contact surfaces 191 of the tabs 190b are configured to abut opposing surfaces defined by substantially flat anterior faces 195 of the distending members 134, 136, only if the viewing elements 106, 118 are urged together beyond the minimum separation distance SD. This arrangement permits the tabs 190b to function as secondary stop members should the posts 190a fail to maintain separation of the viewing elements.

[0112] In other embodiments all of the contact surfaces 191 of the posts 190a and tabs 190b may be configured to contact their respective opposing surfaces when the viewing elements 106, 118 are at the minimum separation distance SD. In still further embodiments, the contact surfaces 191 of the tabs 190b may be configured to contact the opposing surfaces when the viewing elements 106, 118 are at the minimum separation distance SD and the contact surfaces 191 of the posts 190a configured to contact the opposing surfaces only if the viewing elements 106, 118 are urged together beyond the minimum separation distance SD. In one embodiment, the minimum separation distance SD is about 0.1 - 1.0 mm; in another embodiment the minimum separation distance SD is about 0.5 mm.

[0113] When one of the contact surfaces abuts one of the opposing surfaces, the two surfaces define a contact area CA (see Figure 25, depicting an example of a contact area CA defined when the contact surface 191 of a post 190a contacts an opposing surface defined by the perimeter portion 193 of the posterior viewing element 118). Preferably, the contact surface and opposing surface are shaped to cooperatively minimize the size of the contact area, to prevent adhesion between the contact surface and the opposing surface, which is often a concern when one or both of these surfaces has an adhesive affinity for the other. In the embodiment shown, this non-adhesive characteristic is achieved by employing a substantially hemispherical contact surface 191 and a substantially flat opposing surface (perimeter portion 193). Of course, other configurations can be selected for the contact surface(s) 191, including conical, frustoconical, hemicylindrical, pyramidal, or other rounded, tapered or pointed shapes. All of these configurations minimize the contact area CA while permitting the cross-sectional area CS of the stop member 190 (such as the post 190a depicted) to be made larger than the contact area CA, to impart sufficient strength to the stop member despite the relatively small contact area CA. Indeed, when constructing the contact surface(s) 191 any configuration may be employed which defines a contact area CA which is smaller than the cross-sectional area CS of the stop member 190. As further alternatives, the contact surface(s) 191 may be substantially flat and the opposing surface(s) may have a shape which defines, upon contact with the opposing surface, a contact area CA which is smaller than the cross-sectional area CS of the stop member. Thus, the opposing surface(s) may have, for example, a hemispherical, conical, frustoconical, hemicylindrical, pyramidal, or other rounded, tapered or pointed shape.

[0114] Other design features of the stop members 190 can be selected to maximize their ability to prevent adhesion of the contact surface(s) to the corresponding opposing surface(s), or adhesion to each other of any part of the anterior and posterior portions 102, 104 of the lens system 100. For example, the contact and opposing surfaces may be formed from dissimilar materials to reduce the effect of any self-adhesive materials employed in forming the lens system 100. In addition the shape and/or material employed in constructing one or more of the stop members 190 can be selected to impart a spring-like quality to the stop member(s) in question, so that when the stop member is loaded in compression as the viewing elements are urged together at the minimum separation distance, the stop member tends to exert a resisting spring force, due to either

bending or axial compression (or both) of the stop member, which in turn derive from the elasticity of the material(s) from which the stop member is constructed, or the shape of the stop member, or both. This spring-like quality is particularly effective for inhibiting adhesion of areas of the anterior and posterior portions 102, 104 other than the contact surface(s) and opposing surface(s).

[0115] As used herein, the term “adhesion” refers to attachment to each other of (i) an area of the anterior portion 102 of the lens system 100 and (ii) a corresponding area of the posterior portion 104 (other than the apices 112, 116), wherein such attachment is sufficiently strong to prevent, other than momentarily, the anterior and posterior viewing elements 106, 118 from moving apart along the optical axis under the biasing force of the anterior and/or posterior biasing elements 108, 120. If the areas in question are formed of different materials, adhesion may occur where at least one of the materials has an adhesive affinity for the other material. If the areas in question are formed of the same material, adhesion may occur where the material has an adhesive affinity for itself.

[0116] In the embodiment shown, four posts 190a are positioned near the perimeter of the anterior viewing element 106, equally angularly spaced around the optical axis. In addition, two tabs 190b are located on either side of the anterior viewing element, midway between the apices 112, 116 of the lens system. Naturally, the number, type and/or position of the stop members 190 can be varied while preserving the advantageous function of maintaining separation between the anterior and posterior portions of the lens system.

[0117] The illustrated embodiment employs stop members 190 which extend posteriorly from the anterior portion 102 of the lens system 100, so that the contact surfaces 191 are located on the posterior extremities of the stop members 190 and are configured to abut opposing surfaces formed on the posterior portion 104 of the lens system 100. However, it will be appreciated that some or all of the stop members 190 may extend anteriorly from the posterior portion 104 of the lens system 100, so that their contact surfaces 191 are located on the anterior extremities of the stop members 190 and are configured to abut opposing surfaces formed on the anterior portion 102 of the lens system 100.

[0118] Additional features and embodiments of lens systems are described in U.S. Patent Application Nos. 10/020,853 (filed December 11, 2001, and published August

8, 2002 as U.S. 2002/0107568A1) and 10/207,708 (filed July 25, 2002, and published April 17, 2003 as U.S. 2003/0074060A1), which are hereby incorporated by reference herein in their entireties and made a part of this specification.

## **VII. THE LENS SYSTEM: ADDITIONAL EMBODIMENTS**

[0119] Figures 26-37 depict additional embodiments of the intraocular lens. In the illustrated embodiments, the lens systems have distending portions 132 and retention portions 126 for positioning the lens systems in particular configurations within the capsular bag 58.

[0120] Figures 26-28 depict another embodiment 200 of the intraocular lens. It is contemplated that, except as noted below, this embodiment 200 may, in certain embodiments, be similar to any one or more of the embodiments disclosed in Figures 3-17 and Figures 21-25.

[0121] In the illustrated embodiment, the distance 202 between the free end 128b of the first retention member 128 and the free end 130b of the second retention member 130 preferably is between about 6 mm and about 8 mm. In one embodiment, the distance 202 preferably is between about 6.9 mm and about 7.3 mm.

[0122] In the illustrated embodiment, the distance 204 between the free end 134b of the first distending member 134 and the free end 136b of the second distending member 136 preferably is between about 8 mm and about 14 mm. In one embodiment, the distance 204 preferably is between about 9 mm and about 11 mm. In one embodiment, the distance 204 preferably is between about 9.7 mm and about 9.9 mm.

[0123] As shown in Figure 28, the distending members 134, 136 preferably extend from the posterior viewing element 118 at an angle 206 measured with respect to a line 207 which is generally parallel to the lateral axis of the lens 200, as the lens 200 is viewed from above (i.e., along the transverse axis). In one embodiment, the angle 206 preferably is between about 10 degrees and about 25 degrees. The distending members 134, 136 extend from the posterior viewing element 118 by a distance 208 measured along the line 207, generally parallel to the lateral axis. The distance 208 preferably is between about 1 mm and about 4 mm. The length 210 of each of the distending members 134, 136 preferably is between about 1 mm and about 5 mm. In the illustrated embodiment, the distending members 134, 136 are slightly curved and have an anterior radius of curvature 212 of about 19.75 mm and a posterior radius of curvature 214 of about 20 mm.

[0124] Figures 29-31 depict another embodiment 300 of the intraocular lens. It is contemplated that, except as noted below, this embodiment 300 may, in certain embodiments, be similar to any one or more of the embodiments disclosed in Figures 3-17, Figures 21-25, and Figures 26-28.

[0125] In the illustrated embodiment, the distance 302 between the free end 128b of the first retention member 128 and the free end 130b of the second retention member 130 preferably is between about 6 mm and about 8 mm. In one embodiment, the distance 302 preferably is between about 6.9 mm and about 7.3 mm.

[0126] In the illustrated embodiment, the distance 304 between the free end 134b of the first distending member 134 and the free end 136b of the second distending member 136 preferably is between about 8 mm and about 14 mm. In one embodiment, the distance 304 preferably is between about 9 mm and about 11 mm. In one embodiment, the distance 304 preferably is between about 9.7 mm and about 9.9 mm.

[0127] As shown in Figure 31, the distending members 134, 136 preferably extend from the posterior viewing element 118 at an angle 306 measured with respect to a line 307 which is generally parallel to the lateral axis of the lens 300, as the lens 300 is viewed from above (i.e., along the transverse axis). In one embodiment, the angle 306 preferably is between about 20 degrees and about 40 degrees. The distending members 134, 136 extend from the posterior viewing element 118 by a distance 308 measured along the line 307, generally parallel to the lateral axis. The distance 308 preferably is between about 1 mm and about 4 mm. The length 310 of each of the distending members 134, 136 preferably is between about 1 mm and about 5 mm. In the illustrated embodiment, the distending members 134, 136 are slightly curved and have an anterior radius of curvature 312 of about 10.7 mm and a posterior radius of curvature 314 of about 11 mm.

[0128] Figures 32-37 depict another embodiment 400 of the intraocular lens. It is contemplated that, except as noted below, this embodiment 400 may, in certain embodiments, be similar to any one or more of the embodiments disclosed in Figures 3-17, Figures 21-25, Figures 26-28, and Figures 29-31.

[0129] In the illustrated embodiment, the distance 402 between the free end 128b of the first retention member 128 and the free end 130b of the second retention member 130 preferably is between about 6 mm and about 8 mm. In one embodiment, the distance 402 preferably is between about 6.9 mm and about 7.3 mm.

[0130] As best shown in Figures 32 and 35, the retention members 128, 130 are preferably provided with openings 416. Likewise, the transition members 138, 140 are preferably provided with openings 418. These openings 416, 418 preferably permit fluid to flow between the interior of the capsular bag 58 and the portions of the eye anterior of the bag 58 as discussed further below.

[0131] In the illustrated embodiment, the distance 404 between the free end 134b of the first distending member 134 and the free end 136b of the second distending member 136 preferably is between about 8 mm and about 14 mm. In one embodiment, the distance 404 preferably is between about 9 mm and about 11 mm. In one embodiment, the distance 404 preferably is between about 9.7 mm and about 9.9 mm.

[0132] As shown in Figure 34, the distending members 134, 136 preferably extend from the posterior viewing element 118 at an angle 406 measured with respect to a line 407 which is generally parallel to the lateral axis of the lens 400, as the lens 400 is viewed from above (i.e., along the transverse axis). In one embodiment, the angle 406 preferably is between about 10 degrees and about 55 degrees. In one embodiment, the angle 406 preferably is between about 20 degrees and about 40 degrees. In one embodiment, the angle 406 preferably is between about 25 degrees and about 35 degrees. The distending members 134, 136 extend from the posterior viewing element 118 by a distance 408 measured along the line 407 generally parallel to the lateral axis. The distance 408 preferably is between about 1 mm and about 4 mm. The length 410 of each of the distending members 134, 136 preferably is between about 1 mm and about 5 mm. In the illustrated embodiment, the distending members 134, 136 are slightly curved and preferably have an anterior radius of curvature 412 of about 6.2 mm and a posterior radius of curvature 414 of about 6.5 mm.

[0133] In one embodiment, at least one of the first and second distending members 134, 136 connected to the posterior portion 104 of the lens system 400 extends to a location 420 significantly anterior of an anterior surface 424 of the posterior viewing element 118. Preferably, first and second distending members 134, 136 are connected to the posterior portion 104 extend to first and second anterior locations 420, 422, respectively. Each of the first and second anterior locations 420, 422 is significantly anterior of the anterior surface 424 of the posterior viewing element 118.

[0134] As discussed previously, anterior and posterior biasing elements 108, 120 can be connected at first and second apices 112, 116. In one embodiment, each of the

first and second anterior locations 420, 422 is spaced from the first and second apices 112, 116. In some embodiments, one or more of the distending members 134, 136 extends substantially to or beyond a plane 430 that passes through the apices 112, 116 and is oriented perpendicular to the optical axis. Preferably, one, both or all of the first and second anterior locations 420, 422 resides substantially at or anterior of a plane 430 that passes through the apices 112, 116 and is oriented perpendicular to the optical axis. In one embodiment, the first anterior location 420 comprises an anteriormost portion 424 of the first distending member 134, and the second anterior location 422 comprises an anteriormost portion 426 of the second distending member 136.

[0135] Figure 36 depicts the function of the distending portion 132 in greater detail. It is contemplated that, except as noted below, the function of the distending portion 132, in the illustrated embodiment 400, may be similar to the function of the embodiment described with reference to Figures 18-19.

[0136] The lens system 400 is shown situated in the capsular bag 58 in the customary manner with the anterior viewing element 106 and posterior viewing element 118 arranged along the optical axis. The capsular bag 58 is shown with a generally circular anterior opening 66 which may often be cut into the capsular bag during installation of the lens system 400. The first and second distending members 134, 136 of the distending portion 132 distend the capsular bag 58 so that intimate contact is created between the capsular bag 58 and the posterior face of the posterior viewing element and/or the posterior biasing element 120. In addition, intimate contact is facilitated between the capsular bag 58 and the anterior face of the anterior viewing element 106 and/or anterior biasing element 108. The distending members 134, 136 thus remove slack from the capsular bag 58 and ensure optimum force coupling between the bag 58 and the lens system 400 as the bag 58 is alternately stretched and released by the action of the ciliary muscle.

[0137] The distending members 134, 136 preferably position or locate the lens system 400 in a desired orientation within the capsular bag. In one embodiment, the posterior viewing element 118 preferably is positioned in a posterior portion of the capsular bag 58. Typically, the capsular bag 58 has an apex 70 formed along an equator 72 of the capsular bag 58. The distending members 134, 136 preferably extend into the apex 70 to position the lens system 400. For example, the distending members 134, 136 preferably center the lens system 400 within the capsular bag 58 along the lateral axis.

Additionally, in one embodiment, the distending members 134, 136 extend into the apex 70 of the capsular bag 58 and position the posterior viewing element 118 in a posterior portion of the capsular bag 58. In some embodiments, positioning the posterior viewing element 118 further posterior in the capsular bag 58 provides for a greater range of motion in response to the natural accommodation processes of the eye. With reference to Figures 27- 36, any one or combination of the lengths 208, 308, 408, 210, 310, 410, angles 206, 306, 406, and curvatures 212, 312, 412, 214, 314, 414 of the distending members 134, 136 can be adjusted to control how far back the posterior viewing element 118 is positioned in the capsular bag 58. In some embodiments, the capsular bag 58 may be spaced from the posterior viewing element 118 a certain distance for an initial period of time following implantation of the system. In some embodiments, over time, the capsular bag 58 conforms to the shape of the posterior viewing element 118 as shown in Figures 36 and 37. The distending members 134, 136 preferably extend into the apex 70 formed along the equator 72 of the capsular bag 58 to maintain the lens system in a relatively stable position. In some embodiments, the distending members 134, 136 anchor the lens system relative the equator 72 of the capsular bag 58, to hold the posterior viewing element 118 in a desired configuration within a posterior portion of the capsular bag 58.

[0138] Figure 37 shows the function of the retention portion 126 in greater detail. It is contemplated that, except as noted below, the function of the retention portion 126, in the illustrated embodiment 400, may be similar to the function of the embodiment described with reference to Figures 18-19.

[0139] As best seen in Figures 36 and 37, the anterior portion 102 of the lens system 400 forms a number of regions of contact with the capsular bag 58, around the perimeter of the anterior viewing element 106. In the illustrated embodiment, at least some of these regions of contact are located on the anteriormost portions of the anterior biasing element 108, specifically at the transition members 138, 140, and at the retention members 128, 130. As described above with respect to lens system 100, the transition members and the retention members define spaces therebetween at the edges of the anterior viewing element 106 to permit fluid to flow between the interior of the capsular bag 58 and the portions of the eye anterior of the bag 58. In other words, the anterior portion of the lens system 400 includes at least one location which is spaced from and out of contact with the capsular bag 58 to provide a fluid flow channel extending from the region between the viewing elements 106, 118 to the exterior of the bag 58.



[0140] Additionally, in the illustrated embodiment, openings 416, 418 are provided in the retention members 128, 130, and/or in the transition members 138, 140 to permit fluid to flow between the interior of the capsular bag 58 and the portions of the eye anterior of the bag 58. The sizes, configurations, and positions of the openings 416, 418 preferably are selected to allow adequate flow between the interior of the capsular bag 58 and the portions of the eye anterior of the bag 58. As noted above, if the anterior portion 102 of the lens system 400 seals the anterior opening 66 of the bag 58, the resulting prevention of fluid flow can cause the aqueous humor in the capsular bag to stagnate, leading to a clinically adverse event, and can inhibit the movement of the lens system 400 between the accommodated and unaccommodated states.

[0141] Although the function of the distending portion 132 and retention portion 126 are described with reference to lens system 400, other embodiments, such as for example, lens system 200 and lens system 300, preferably can function in a similar manner.

#### **VIII. THE LENS SYSTEM: BIASING ELEMENTS**

[0142] Figures 38-40 depict another embodiment 500 of the intraocular lens system. It is contemplated that, except as noted below, this lens system 500 may, in certain embodiments, be similar to any one or more of the other embodiments 100, 200, 300, 400 disclosed herein. Additionally, the features described with respect to Figures 38-40 may, in certain embodiments, be incorporated into one or more of the other embodiments disclosed herein, or described in U.S. Patent No. 6,818,158, issued November 16, 2004, titled ACCOMMODATING INTRAOCULAR LENS SYSTEM AND METHOD OF MAKING SAME, the entirety of which is hereby incorporated by reference herein and made a part of this specification.

[0143] In one embodiment, an accommodating intraocular lens system 500 comprises first and second viewing elements 506, 518 interconnected by a biasing member 505 such that the viewing elements 506, 518 are relatively movable (upon implantation of the lens system 500 in the capsular bag) in response to the ciliary muscle 60 of the eye 50. The biasing member 505 preferably exerts a biasing force that relatively moves the viewing elements 506, 518 along an optical axis of the intraocular lens 500. The standard bias force characteristic of the biasing member 505 preferably is between about 50 mg and about 750 mg, as described in more detail below.

[0144] As shown in Figures 38-40, the first viewing element 506 is on an anterior side of the intraocular lens 500 and the second viewing element 518 is on a posterior side of the intraocular lens 500. The first viewing element 506 preferably comprises an optic on the anterior side, and the second viewing element 518 preferably comprises an optic on the posterior side. In another embodiment, the second viewing element 518 comprises an open space on the posterior side of the intraocular lens 500. The second viewing element 518 can alternatively comprise a hoop that surrounds the open space. As shown in Figures 38-40, the accommodating intraocular lens 500 can include first and second distending members 534, 536 on a posterior side of the intraocular lens 500.

[0145] The biasing member 505 preferably comprises an anterior biasing element 508 and a posterior biasing element 520. The anterior biasing element 508 can be connected to the posterior biasing element 520 at first and second apices 512, 516. As stated above, the biasing member 505 produces a biasing force that relatively moves the viewing elements 506, 518 along an optical axis of the intraocular lens 500. In one embodiment, the biasing member 505 has a geometry such that the anterior first viewing element 506 moves more than the posterior second viewing element 518 along the optical axis in response to ciliary muscle action.

[0146] In some embodiments, the anterior biasing element 508 may be generally similar to any of the embodiments of the anterior biasing element 108 disclosed herein, and/or the posterior biasing element 520 may be generally similar to any of the embodiments of the posterior biasing element 120 disclosed herein. Moreover, although the depicted biasing member 505 comprises the anterior biasing element 508 and posterior biasing element 520, any suitable alternative structure may be employed as the biasing member 505.

[0147] The anterior and posterior biasing elements 508, 520 function in a spring-like manner to permit the anterior viewing element 506 and posterior viewing element 518 to move relative to each other generally along the optical axis. The biasing elements 508, 520 bias the viewing elements 506, 518 apart so that the viewing elements 506, 518, separate to the accommodated position or accommodated state shown in Figures 38-39. Thus, in the absence of any external forces, the viewing elements are at their maximum separation along the optical axis. The viewing elements 506, 518 of the lens system 500 may be moved toward each other, in response to a ciliary muscle force to

provide an unaccommodated position by applying appropriate forces upon the anterior and posterior portions 502, 504 and/or the apices 512, 516.

[0148] When the lens system 500 is implanted in the capsular bag 58 the above described biasing forces cause the lens system 500 to expand along the optical axis so as to interact with both the posterior and anterior aspects of the capsular bag 58. Such interaction preferably occurs throughout the entire range of motion of the ciliary muscle 60. At one extreme the ciliary muscle 60 is relaxed and the zonules 62 pull the capsular bag 58 radially so as to cause the bag to become more disk shaped. The anterior and posterior sides of the bag, in turn, apply force to the anterior and posterior portions of the lens system 500, thereby forcing the viewing elements 506, 518 toward each other into the unaccommodated state. At the other extreme, the ciliary muscle 60 contracts and the zonules 62 move inwardly to provide slack in the capsular bag 58 and allow the bag to become more football-shaped. The slack in the bag is taken up by the lens system due to the biasing-apart of the anterior and posterior viewing elements 506, 518. As the radial tension in the bag is reduced, the viewing elements 506, 518 move away from each other into an accommodated state. Thus, the distance between the viewing elements 506, 518 depends on the degree of contraction or relaxation of the ciliary muscle 60. As the distance between the anterior and posterior viewing elements 506, 518 is varied, the focal length of the lens system 500 changes accordingly. Thus, when the lens system 500 is implanted into the capsular bag, the lens system 500 operates in conjunction with the natural accommodation processes of the eye to move between the accommodated and unaccommodated states in the same manner as would a healthy "natural" lens. Preferably, the lens system 500 can move between the accommodated and unaccommodated states in less than about one second.

[0149] The lens system 500 has sufficient dynamic range that the anterior and posterior viewing elements 506, 518 move about 0.5-4 mm, preferably about 1-3 mm, more preferably about 1-2 mm, and most preferably about 1.5 mm closer together when the lens system 500 moves from the accommodated state to the unaccommodated state. In other words the separation distance  $X$  between the anterior and posterior viewing elements 506, 518, which distance may for present purposes be defined as the distance along the optical axis (or a parallel axis) between a point of axial intersection with the posterior face of the anterior viewing element 506 and a point of axial intersection with the anterior face of the posterior viewing element 518, decreases by the amount(s)

disclosed above upon movement of the lens system 500 to the unaccommodated state. Simultaneously, in one preferred mode the total system thickness  $Y$  decreases from about 3.0 - 4.0 mm in the accommodated state to about 1.5 - 2.5 mm in the unaccommodated state.

[0150] As stated above, the biasing member 505 produces a biasing force that relatively moves the viewing elements 506, 518 along an optical axis of the intraocular lens 500. In one embodiment, the biasing force developed by the lens system acts in response to an applied force on the lens. As stated above, the biasing member 505 preferably has a standard bias force characteristic. The standard bias force characteristic corresponds to the magnitude of the biasing force developed by the lens system acting in response to an applied force on the lens, where the applied force is sufficient to move the first viewing element between a first position and a second position relative to the second viewing element along an optical axis of the accommodating intraocular lens, and where the first position is about 1 mm from the second position along the optical axis.

[0151] The standard bias force characteristic can be determined by applying a force  $F$  to the accommodating intraocular lens 500. The force  $F$  applied to the lens 500 is sufficient to move the first viewing element 506 from a first position (e.g., Figure 39) to a second position (e.g., Figure 40) relative to the second viewing element 518 along the optical axis, wherein the first position is about 1 mm from the second position along the optical axis. The magnitude of the force  $F$  applied to move the first viewing element 506 from the first position to the second position is measured to determine the magnitude of the standard bias force characteristic of the accommodating intraocular lens 500.

[0152] For example, as shown in Figures 39-40, the accommodating intraocular lens 500 can be positioned against a surface  $S$ . As shown in Figure 39, the accommodating intraocular lens 500 has viewing elements 506, 518 at their maximum separation along the optical axis in the absence of any external forces. The force  $F$  can be applied to the lens 500 to move the first viewing element 506 from the first position to the second position while holding the second viewing element 518 generally stationary. The first position is a distance  $D$  from the second position along the optical axis. The distance  $D$  is about 1 mm. The applied force  $F$  acts to move the viewing elements 506, 518 of the lens system 500 toward each other in the illustrated embodiment. Accordingly, the second position is located between the first position and the second viewing element 518 along the optical axis. The magnitude of the force  $F$  required to move the first viewing

element 506 from the first position to the second position is equal to the magnitude of the biasing force of the biasing member 505. The standard bias force characteristic is equivalent to the magnitude of the biasing force acting in response to the movement of the first viewing element 506 1 mm from the first position to the second position relative to the second viewing element 518.

[0153] It has been discovered empirically that in an accommodating intraocular lens having first and second viewing elements, a biasing member 505 having a standard bias force characteristic between about 50 mg and about 750 mg is advantageous. The standard bias force characteristic of the biasing member 505 can allow the accommodating intraocular lens 500 to respond to the action of the ciliary muscle and preferably achieves a full range of accommodation. A standard bias force characteristic between about 50 mg and about 750 mg produces improved response to the action of the ciliary muscle.

[0154] In one embodiment, the biasing member 505 has a standard bias force characteristic that is between about 50 mg and about 750 mg. In another embodiment, the biasing member 505 has a standard bias force characteristic that is between about 50 mg and about 200 mg. In another embodiment, the biasing member 505 has a standard bias force characteristic that is between about 100 mg and about 200 mg. In another embodiment, the biasing member 505 has a standard bias force characteristic that is between about 120 mg and about 180 mg. In another embodiment, the biasing member 505 has a standard bias force characteristic that is between about 120 mg and about 160 mg. In another embodiment, the biasing member 505 has a standard bias force characteristic that is between about 140 mg and about 150 mg.

[0155] In one application, a method for determining a standard bias force characteristic of a biasing member 505 of an accommodating intraocular lens comprises providing an accommodating intraocular lens having first and second viewing elements interconnected by a biasing member 505. A force is applied to the accommodating intraocular lens sufficient to move the first viewing element between a first position and a second position relative to the second viewing element along an optical axis of the accommodating intraocular lens. The magnitude of the force applied to move the first viewing element between the first position and the second position is measured. The first position is about 1 mm from the second position along the optical axis. In one

application, the second position is located between the first position and the second viewing element along the optical axis.

[0156] In another application, a method for treating a patient comprises providing an accommodating intraocular lens comprising first and second viewing elements interconnected by a biasing member 505 such that the viewing elements are relatively movable in response to the ciliary muscle of the eye. The standard bias force characteristic of the biasing member 505 is between about 50 mg and about 750 mg. The accommodating intraocular lens is inserted into an eye of the patient. The biasing member 505 produces a biasing force that relatively moves the viewing elements along an optical axis of the intraocular lens.

#### **IX. ACCOMMODATING INTRAOCULAR LENS SYSTEM WITH ABERRATION-ENHANCED PERFORMANCE**

[0157] Figures 41-44 depict two types of relative movement of the anterior and posterior viewing elements 106, 118 of the lens system 100, which promote aberration in the optical properties of the lens system 100. As will be explained in further detail below, the resulting aberration enhances the optical performance of the lens system.

[0158] Figures 41-42 depict tilting action of the anterior viewing element 106 of the lens system 100. In discussing this tilting action, it is helpful to consider the anterior viewing element 106 as having an anterior optical axis AOA and the posterior viewing element 118 as having a posterior optical axis POA, as shown in Figures 41-42. When the lens system 100 is unstressed, and/or during some conditions of use, the anterior optical axis AOA and posterior optical axis POA are generally collinear with each other (thus defining a common optical axis of the lens system 100).

[0159] However, it is preferable that, when implanted, the anterior viewing element 106 can tilt with respect to the posterior viewing element 118, for example about a tilt axis generally parallel to the lateral axis depicted in Figure 3. The tilt axis of the anterior viewing element 106 in this case is thus spaced from, and generally orthogonal to, the transverse axis which passes through the first and second apices 112, 116. (The transverse axis can thus be considered an "apical axis.") When the anterior viewing element 106 tilts in this manner, the anterior optical axis AOA also tilts to a similar degree with respect to the posterior optical axis POA. Thus is defined a tilt angle  $\alpha$  between the anterior and posterior optical axes AOA, POA as shown in Figure 42.

[0160] The anterior viewing element 106 can preferably tilt about an axis generally parallel to the lateral axis as discussed above. However, in some embodiments the anterior viewing element 106 can tilt about a different axis or different axes (e.g., any other axis generally orthogonal to the posterior optical axis POA) instead of or in addition to an axis generally parallel to the lateral axis. Where present, multi-axis tiltability of the anterior viewing element 106 may involve tilting of the anterior viewing element about two or more axes at the same time.

[0161] Due to the construction of the lens, asymmetric and/or off-axis forces exerted by the capsular bag on the lens system 100 during use, can cause the anterior viewing element 106 to tilt as the lens system 100 moves between the unaccommodated state and the accommodated state. The degree of tilt can vary as the anterior viewing element moves between its unaccommodated position and its accommodated position. The degree of tilt typically increases as the anterior viewing element 106 moves from its unaccommodated position to its accommodated position. Thus the anterior viewing element 106 may change from a less-tilted (or a substantially non-tilted) orientation when in its unaccommodated position, to a more-tilted orientation when in its accommodated position. Preferably, the tilt angle  $\alpha$  does not exceed 10 degrees anywhere in the range of motion of the anterior viewing element 106. In other embodiments this maximum tilt angle can be 7.5 degrees, 5 degrees or 2.5 degrees, or some angle greater than 10 degrees. In still other embodiments the maximum tilt angle can be within the range of 2.5 degrees to 10 degrees, or within the range of 5 degrees to 7.5 degrees.

[0162] Figures 43-44 depict decentration movement of the anterior viewing element 106 of the lens system 100. As discussed above, when the lens system 100 is unstressed, and/or during some conditions of use, the anterior optical axis AOA and posterior optical axis POA are generally collinear with each other (thus defining a common optical axis of the lens system 100). This condition is shown schematically in Figure 43, in which the viewing elements 106, 118 are viewed along the collinear optical axes AOA, POA.

[0163] However, it is preferable that, when implanted, the anterior viewing element 106 can decenter with respect to the posterior viewing element 118, so that the viewing elements 106, 118 take on the configuration shown schematically in Figure 44. When the anterior viewing element 106 decenters in this manner, the anterior and posterior optical axes AOA, POA are no longer collinear. Thus is defined a decentration

distance DD between the anterior and posterior optical axes AOA, POA as shown in Figure 44.

[0164] Due to the construction of the lens, asymmetric and/or off-axis forces exerted by the capsular bag on the lens system 100 during use, can cause the anterior viewing element 106 to decenter with respect to the posterior viewing element 118 as the lens system 100 moves between the unaccommodated state and the accommodated state. The decentration distance DD can vary as the anterior viewing element moves between its unaccommodated position and its accommodated position. The decentration distance DD typically increases as the anterior viewing element 106 moves from its unaccommodated position to its accommodated position. Thus the anterior viewing element 106 may change from a less-decentered (or a substantially centered) orientation when in its unaccommodated position, to a more-decentered orientation when in its accommodated position. Preferably, the decentration distance DD does not exceed 1.0 mm anywhere in the range of motion of the anterior viewing element 106. In other embodiments this maximum decentration distance can be 0.75 mm, 0.5 mm or 0.25 mm, or, alternatively, some distance greater than 1.0 mm. In still other embodiments, the maximum decentration distance DD is within the range of 0.25 mm to 1.0 mm, or within the range of 0.25 mm to 0.75 mm.

[0165] In order to allow the anterior optic to tilt and/or decenter from its "natural" untilted and centered orientation, the lens system is formed of a material (e.g., a polymer material such as silicone having a Young's modulus of about 300 P.S.I.) which permits both the anterior biasing element 108 as a whole, as well as the connections of the anterior viewing element 106 to the anterior biasing element 108 to readily deform. The elastic properties of certain of the materials suitable for forming the anterior biasing element 108 and/or the lens system 100 as a whole, promote a resilient or spring-like return force which tends to urge the anterior viewing element 106 toward the untilted and centered configuration when tilt-promoting and decentration-promoting forces are not (or no longer) acting on the anterior viewing element 106. Of course, in other embodiments the lens system may be constructed such that this natural orientation of the anterior viewing element is a tilted and/or decentered orientation.

[0166] The tilt and/or decentration action of the anterior viewing element is facilitated by design features which may be incorporated, individually or in any suitable combination, in various embodiments of the lens system 100. For example, the anterior



viewing element 106 can be connected to the anterior biasing element 108 at only two, substantially diametrically opposed, locations, where the anterior viewing element 106 joins the anterior biasing element 108, e.g., via the first and second transition members 138, 140 (see Figures 6, 22, 26, 29, 32). In addition, the size of these attachment locations can be made sufficiently small (again, see Figures 6, 22, 26, 29, 32) to permit the anterior viewing element 106 to tilt and/or decenter as described above. In the embodiment illustrated in Figure 6, each attachment location spans about 45 degrees of the circumference of the anterior viewing element 106; thus, the anterior viewing element 106 is fixed to the anterior biasing element 108 along about 90 degrees of the circumference of the viewing element, and is unattached or free along the remaining 270 degrees. In the embodiments of Figures 22, 26 and 29, each attachment location spans about 60 degrees of the circumference of the anterior viewing element 106; thus, the anterior viewing element 106 is fixed to the anterior biasing element 108 along about 120 degrees of the circumference of the viewing element, and is unattached or free along the remaining 240 degrees. In the embodiment of Figure 32, each attachment location spans about 90 degrees of the circumference of the anterior viewing element 106; thus, the anterior viewing element 106 is fixed to the anterior biasing element 108 along about 180 degrees of the circumference of the viewing element, and is unattached or free along the remaining 180 degrees.

[0167] More generally, the anterior viewing element 106 can be fixed to the anterior biasing element 108 along less than or equal to about 240 degrees of the circumference of the anterior viewing element, or between about 30 degrees and about 240 degrees of the circumference of the anterior viewing element, while the anterior viewing element is free or unattached to the anterior biasing element along the remaining circumference. (In Figure 29, the span along which the anterior viewing element 106 is fixed to the anterior biasing element 108 is two times the indicated angle  $\alpha$ .) Preferably, the span along which the anterior viewing element is fixed to the anterior biasing element is divided evenly between two substantially diametrically opposed attachment locations, as discussed above and shown in Figures 6, 22, 26, 29 and 32.

[0168] Where the anterior viewing element 106 is non-circular, the anterior viewing element 106 can be fixed to the anterior biasing element 108 along less than or equal to about two-thirds of the perimeter of the anterior viewing element, or between about one-twelfth and two-thirds of the perimeter, as the anterior viewing element is

observed along the optical axis (similar to the view in Figure 6), while the anterior viewing element is unattached or free along the remaining perimeter. Preferably, the span along which the anterior viewing element is fixed to the (non-circular) anterior biasing element is divided evenly between two substantially opposed attachment locations, as discussed above and shown in Figures 6, 22, 26, 29 and 32.

[0169] When included in the lens system 100, the retention portion 126 can also contribute to a tilting and/or decentration action of the anterior viewing element 106. The retention portion 126, preferably in the form of at least first and second retention members 128, 130, can provide regions of contact with the capsular bag, and facilitate application of force to the anterior viewing element 106, at location(s) spaced from the tilt axis of the anterior viewing element. The first and second retention members 128, 130 are particularly effective for this tilt- and decenter-promoting force application when they provide regions of contact that are located angularly about midway between the locations (e.g., the transition members 138, 140) where the anterior viewing element 106 is fixed to the anterior biasing element. The retention members 128, 130, and/or the regions of contact provided by the retention members 128, 130, can also be situated on an axis which is substantially orthogonal to the tilt axis of the anterior viewing element 106. (Such an arrangement is shown in Figures 6, 22, 26, 29 and 32.) The retention members 128, 130, and/or the regions of contact provided by the retention members 128, 130, can also be substantially diametrically opposed from each other. (Such an arrangement is also shown in Figures 6, 22, 26, 29 and 32.) In other embodiments, more or fewer than two retention members may be employed, and the retention members/regions of contact may be located other than angularly midway between the attachment locations.

[0170] As another tilt-promoting design feature that may be employed instead of or in addition to any one or more of the other tilt-promoting features discussed herein, the anterior biasing element 108 (or, more particularly, any one or more of the first anterior translation member 110, second anterior translation member 114, and the arms 110a, 110b, 114a, 114b) can have a cross-section with a relatively broad dimension oriented generally transverse to the optical axis of the anterior viewing element 106 (e.g., generally parallel to the lateral axis), and a relatively narrow dimension oriented generally transverse to the relatively broad dimension (e.g., generally parallel to the optical axis). Appropriate cross-sections of this type are shown in Figures 17B-17L. Such a configuration of the anterior biasing element 108, translation members 110, 114, and/or

arms 110a, 110b, 114a, 114b facilitates preferential bending of the element/member(s)/arm(s) about an axis transverse to the optical axis of the anterior viewing element 106, which in turn facilitates tilting of the anterior viewing element 106 in the manner shown in Figures 41-42. In some embodiments, a cross-section of the type presently described prevails along any one or more of the anterior biasing element 108, translation members 110, 114, and/or arms 110a, 110b, 114a, 114b, at least in the portion(s) of the element/member(s)/arm(s) in question that are adjacent the transition member(s) 138, 140 (or adjacent the attachment locations where the anterior viewing element 106 is fixed to the anterior biasing element 108).

[0171] In still other embodiments, any one or more of the first anterior translation member 110, second anterior translation member 114, and the arms 110a, 110b, 114a, 114b can be configured to contact the inner wall of the capsular bag, preferably along substantially the entire length of the element/member(s)/arm(s) in question. Such an arrangement can promote tilting and/or decentration action of the anterior viewing element 106 under some circumstances. Also, an "asymmetric" arrangement of the biasing elements 108, 120, including the various asymmetric arrangements discussed herein in connection with Figures 17M-17N, can be employed with a tilting and/or decentering anterior viewing element 106, instead of or in addition to any one or more of the tilt-promoting features described in this specification.

[0172] In still other embodiments, the lens system has an anterior optic which can tilt and/or decenter according to an aberration-inducing force characteristic. The aberration-inducing force characteristic is defined as the force required to displace a point on the periphery of the anterior optic of the lens system by 1 mm, wherein the force applied to such point acts along a line oriented in an anterior-to-posterior direction (i.e., parallel to the optical axis of the lens system when the anterior optic is in a neutral or un-tilted orientation). The 1 mm displacement is measured along the above-mentioned anterior-to-posterior direction. The force is applied vertically with the posterior viewing element of the lens system supported such that the anterior optic is situated directly above the posterior viewing element, while the lens system is submerged in water at room temperature.

[0173] In various embodiments, the lens system 100/200/250/300/350/400/500 can have an aberration-inducing force characteristic of about 70 mg to about 115 mg. An aberration-inducing force characteristic within this

range is a good predictor of a lens system which will provide tilt and/or decentration movement of the anterior viewing element 106 as discussed in this section.

[0174] Figure 45 illustrates the measurement of the aberration-inducing force characteristic of the lens system 400 of Figures 32-37. The retention members 128, 130 are removed to avoid interfering with the measurement, and the lens system 400 is submerged in water at room temperature with the posterior viewing element 118 of the lens system 400 supported such that the anterior viewing element 106 is situated directly above the posterior viewing element 118. An actuator 600 is positioned above the anterior viewing element 106 and is moveable vertically along the above-mentioned anterior-to-posterior direction. With the actuator 600 so positioned, a linear, downward movement of the actuator 600 will cause the actuator 600 to contact the anterior viewing element 106 at a contact point CP (see Figure 32). In the embodiment depicted, the contact point CP is located at the periphery of the anterior viewing element 106 midway between the transition members 138, 140.

[0175] The actuator 600 is advanced downward into or through a "ready" position in which the actuator just contacts the anterior viewing element 106 at the contact point CP, without moving or tilting the anterior viewing element from its neutral position. The actuator 600 is then advanced 1 mm further downward, thus urging the anterior viewing element 106 into a tilted configuration. At this point the actuator 600 and the contact point CP of the anterior viewing element 106 are considered to be in a "final" position.

[0176] The aberration-inducing force characteristic is then determined by measuring the force exerted by the actuator 600 (and/or the opposing reaction force exerted by the lens system 400 against the actuator 600 at the contact point CP) when in the final position. In such manner, an aberration-inducing force characteristic can be determined for any contact point on the periphery of the anterior viewing element 106, including without limitation the contact point CP and the second contact point CP2 illustrated in Figure 32.

[0177] The table below illustrates force and tilt measurements observed in four different lens systems having the geometry of the lens system 400 shown in Figures 32-37. Each lens was analyzed in the manner depicted in Figure 45, to determine the forces and tilt angles associated with displacing the contact point CP and, separately, a second contact point CP2 located on the periphery of the anterior viewing element 106

and 90 degrees away from the contact point CP (see Figure 32) by distances of 0.25 mm, 0.50 mm, 0.75 mm and 1.00 mm. The second contact point CP2 illustrated in Figure 32 is located substantially at the angular midpoint of the region of contact formed at the junction of the transition member 140 to the anterior viewing element 106.

| Lens No.  | Contact Point Displacement (mm) | Measurements at Contact Point CP |            | Measurements at Second Contact Point CP2 |            |
|-----------|---------------------------------|----------------------------------|------------|--|------------|
|           |                                 | Tilt (degrees)                   | Force (mg) | Tilt (degrees)                           | Force (mg) |
| 1         | 0.25                            | 2.30                             | 28         | 1.80                                     | 35         |
|           | 0.50                            | 4.87                             | 55         | 3.93                                     | 62         |
|           | 0.75                            | 7.30                             | 73         | 6.47                                     | 85         |
|           | 1.00                            | 9.60                             | 89         | 9.63                                     | 105        |
| 2         | 0.25                            | 3.27                             | 32         | 2.10                                     | 36         |
|           | 0.50                            | 5.43                             | 61         | 4.10                                     | 60         |
|           | 0.75                            | 7.83                             | 88         | 6.60                                     | 85         |
|           | 1.00                            | 10.17                            | 111        | 9.60                                     | 106        |
| 3         | 0.25                            | 2.87                             | 29         | 2.10                                     | 29         |
|           | 0.50                            | 5.53                             | 36         | 4.13                                     | 47         |
|           | 0.75                            | 7.87                             | 53         | 6.77                                     | 72         |
|           | 1.00                            | 10.20                            | 75         | 9.77                                     | 91         |
| 4         | 0.25                            | 2.77                             | 28         | 1.90                                     | 30         |
|           | 0.50                            | 5.20                             | 50         | 4.10                                     | 60         |
|           | 0.75                            | 7.70                             | 64         | 6.83                                     | 83         |
|           | 1.00                            | 10.13                            | 86         | 10.10                                    | 97         |
| (average) | 0.25                            | 2.8                              | 29         | 2.0                                      | 33         |
|           | 0.50                            | 5.3                              | 51         | 4.1                                      | 57         |
|           | 0.75                            | 7.7                              | 70         | 6.7                                      | 81         |
|           | 1.00                            | 10.0                             | 90         | 9.8                                      | 100        |

[0178] The tilt and decentration action of the anterior viewing element 106 described herein can facilitate a vision correction (e.g., improved range of accommodation and/or improved depth of field) greater than that otherwise obtained due to the refractive power and the relative axial movement of the viewing elements 106, 118 alone. The tilting and decentration movement alters the refractive properties of the lens system by introducing beneficial optical aberration. This in turn facilitates a wider range of accommodation and better depth of focus of the lens system, in comparison to a similar system that lacks a beneficial tilting or decentration action. The decentration action is

believed to provide a greater contribution to the increase in depth of focus than does the tilting action.

[0179] The tilt and/or decentration action and tiltable and/or dcenterable anterior viewing element depicted in Figures 41-44 and described in this section, and/or the tilt-promoting or decentration-promoting structures described in this section, may be incorporated into any of the embodiments of the lens system described herein, including but not limited to the lens system 100 of Figures 3-17L and 18-19, the lens system 250 of Figures 17M-17N, the lens system 350 of Figure 17P, the lens system 100 of Figure 20, the lens system 100 of Figures 21-25, the lens system 200 of Figures 26-28, the lens system 300 of Figures 29-31, the lens system 400 of Figures 32-33, the lens system 400 of Figures 34-37, and/or the lens system 500 of Figures 38-40. In various embodiments, the lens systems can provide a tilting action alone or a decentration action alone, or both a tilting action and a decentration action as discussed herein. The tilting and/or decentration action can be provided in a lens system which has an anterior viewing element 106/etc. comprising an optic with a power of +25 diopters or more.

[0180] Although this invention has been disclosed in the context of certain preferred embodiments and examples, it will be understood by those skilled in the art that the present invention extends beyond the specifically disclosed embodiments to other alternative embodiments and/or uses of the invention and obvious modifications and equivalents thereof. Thus, it is intended that the scope of the present invention herein disclosed should not be limited by the particular disclosed embodiments described above, but should be determined only by a fair reading of the claims that follow.

WHAT IS CLAIMED IS:

1. An accommodating intraocular lens implantable in an eye, the lens comprising:

an anterior portion having an anterior biasing element and an anterior optic having refractive power; and

a posterior portion having a posterior biasing element and a posterior optic having refractive power;

the anterior optic and the posterior optic being relatively moveable in response to action of the ciliary muscle to change the separation between the optics and the refractive power of the lens;

the lens having an aberration-inducing force characteristic of about 70 mg to about 115 mg to allow aberration-inducing relative movement of the optics when the lens is in the eye, thereby adding optical aberration to the lens which increases depth of focus of the lens.

2. The lens of Claim 1, wherein the aberration-inducing relative movement comprises tilting movement of the anterior optic.

3. The lens of Claim 1, wherein the aberration-inducing relative movement comprises decentration movement of the anterior optic.

4. The lens of Claim 1, wherein the aberration-inducing relative movement comprises both tilting movement and decentration movement of the anterior optic.

5. The lens of Claim 1, wherein the anterior biasing element has a cross-section with a relatively broad dimension oriented generally transverse to an optical axis, and a relatively narrow dimension oriented generally transverse to the relatively broad dimension.

6. The lens of Claim 1, wherein the anterior biasing element comprises a first translation member comprising a first arm and a second arm, each of said first arm and said second arm having a cross-section with a relatively broad dimension oriented



generally transverse to an optical axis of the anterior optic, and a relatively narrow dimension oriented generally transverse to the relatively broad dimension.

7. The lens of Claim 6, wherein the anterior biasing element comprises a second translation member comprising a third arm and a fourth arm, each of said third arm and said fourth arm having a cross-section with a relatively broad dimension oriented generally transverse to the optical axis of the anterior optic when the anterior optic is not tilted, and a relatively narrow dimension oriented generally transverse to the relatively broad dimension.

8. The lens of Claim 1, wherein the anterior optic has a refractive power of +25 diopters or more.

9. An accommodating intraocular lens implantable in an eye having an optical axis, the lens comprising:

an anterior portion having an anterior biasing element and an anterior viewing element, the anterior viewing element comprising an optic having refractive power;

a posterior portion having a posterior viewing element;

the anterior biasing element attached to the periphery of the anterior viewing element at substantially diametrically opposed first and second attachment locations;

the periphery of the anterior viewing element being unattached to the anterior biasing element between the first and second attachment locations;

the size of the first and second attachment locations being sufficiently small such that the optical axis of the anterior optic tilts and/or decenters relative to the optical axis of the eye during movement of the anterior optic relative to the posterior viewing element.

10. The lens of Claim 9, further comprising a first retention member extending radially outwardly from a periphery of said anterior viewing element.

11. The lens of Claim 10, further comprising a second retention member extending radially outwardly from a periphery of said anterior viewing element.

12. The lens of Claim 11, wherein said first retention member is located angularly midway between said attachment locations, and said second retention member is located angularly midway between said attachment locations and substantially diametrically opposed from said first retention member.

13. The lens of Claim 9, wherein said anterior biasing element is configured to contact the interior of the capsular bag of the eye along substantially the entire length of said anterior biasing element.

14. The lens of Claim 9, wherein the anterior biasing element has a cross-section with a relatively broad dimension oriented generally transverse to the optical axis of the anterior optic when the anterior optic is not tilted, and a relatively narrow dimension oriented generally transverse to the relatively broad dimension.

15. The lens of Claim 9, wherein the anterior biasing element comprises a first translation member comprising a first arm and a second arm, each of said first arm and said second arm having a cross-section with a relatively broad dimension oriented generally transverse to the optical axis of the anterior optic when the anterior optic is not tilted, and a relatively narrow dimension oriented generally transverse to the relatively broad dimension.

16. The lens of Claim 15, wherein the anterior biasing element comprises a second translation member comprising a third arm and a fourth arm, each of said third arm and said fourth arm having a cross-section with a relatively broad dimension oriented generally transverse to the optical axis of the anterior optic when the anterior optic is not tilted, and a relatively narrow dimension oriented generally transverse to the relatively broad dimension.

17. The lens of Claim 9, wherein:

the posterior portion further comprises a posterior biasing element attached to the posterior viewing element at third and fourth attachment locations;

the anterior portion and posterior portion meeting at first and second apices of the intraocular lens such that a plane passing through both apices is closer to

one of the first attachment location and the third attachment location than to the other of the first attachment location and the third attachment location.

18. The lens of Claim 9, wherein said anterior optic tilts by 2.5 degrees to 10 degrees relative to the optical axis of the eye during movement of the anterior optic relative to the posterior viewing element.

19. The lens of Claim 9, wherein said anterior optic decenters by 0.25 mm to 1.0 mm relative to the optical axis of the eye during movement of the anterior optic relative to the posterior viewing element.

20. The lens of Claim 9, wherein the size of the first and second attachment locations is sufficiently small such that the optical axis of the anterior optic both tilts and decenters relative to the optical axis of the eye during said relative movement.

21. The lens of Claim 9, wherein the anterior biasing element is formed from a material having a Young's modulus of about 300 P.S.I.

22. The lens of Claim 9, wherein the anterior optic has a refractive power of +25 diopters or more.

23. An accommodating intraocular lens system comprising:  
an anterior optic having a positive refractive power, said anterior optic having an anterior optical axis;  
a posterior optic having a negative refractive power, said posterior optic having a posterior optical axis;  
said optics mounted to move generally along an anterior-to-posterior direction relative to each other in response to ciliary muscle action, said optics having within their range of relative motion a first configuration in which said anterior optical axis is sufficiently misaligned relative to said posterior optical axis to introduce optical aberration in the lens that increases depth of focus relative to the depth of focus that would exist if said axes of said optics were aligned.

24. The lens system of Claim 23, wherein said anterior optical axis is tilted relative to said posterior optical axis when said optics are in said first configuration.

25. The lens system of Claim 24, wherein said anterior optical axis is tilted by 2.5 degrees to 10 degrees relative to said posterior optical axis when said optics are in said first configuration.

26. The lens system of Claim 24, wherein said anterior optical axis is tilted by 5 degrees to 7.5 degrees relative to said posterior optical axis when said optics are in said first configuration.

27. The lens system of Claim 23, wherein said anterior optical axis is decentered relative to said posterior optical axis when said optics are in said first configuration.

28. The lens system of Claim 27, wherein said anterior optical axis is decentered by 0.25 mm to 1.0 mm relative to said posterior optical axis when said optics are in said first configuration.

29. The lens system of Claim 27, wherein said anterior optical axis is decentered by 0.5 mm to 7.5 mm relative to said posterior optical axis when said optics are in said first configuration.

30. The lens system of Claim 23, wherein said anterior optical axis is both tilted and decentered relative to said posterior optical axis when said optics are in said first configuration.

31. The lens system of Claim 23, wherein the anterior optic has a refractive power of +25 diopters or more.

32. A method of manufacturing an accommodating intraocular lens, the method comprising:

configuring biasing elements of said lens such that, when implanted, (i) an anterior optic of positive refractive power moves relative to a posterior optic of negative refractive power to change the separation between the optics along an

anterior-to-posterior direction, and (ii) the anterior optic tilts and/or decenters relative to a posterior optical axis during relative movement of the optics so as to provide accommodation greater than that due to the refractive power and separation changes alone.

33. The method of Claim 32, wherein providing greater accommodation comprises increasing depth of focus.

34. The method of Claim 32, further comprising configuring said biasing elements such that the anterior optic tilts by 2.5 degrees to 10 degrees relative to the posterior optical axis during relative movement.

35. The method of Claim 32, further comprising configuring said biasing elements such that the anterior optic decenters by 1 mm or less relative to the posterior optical axis during relative movement.

36. The method of Claim 32, further comprising configuring said biasing elements such that the anterior optic both tilts and decenters relative to the posterior optical axis during relative movement.

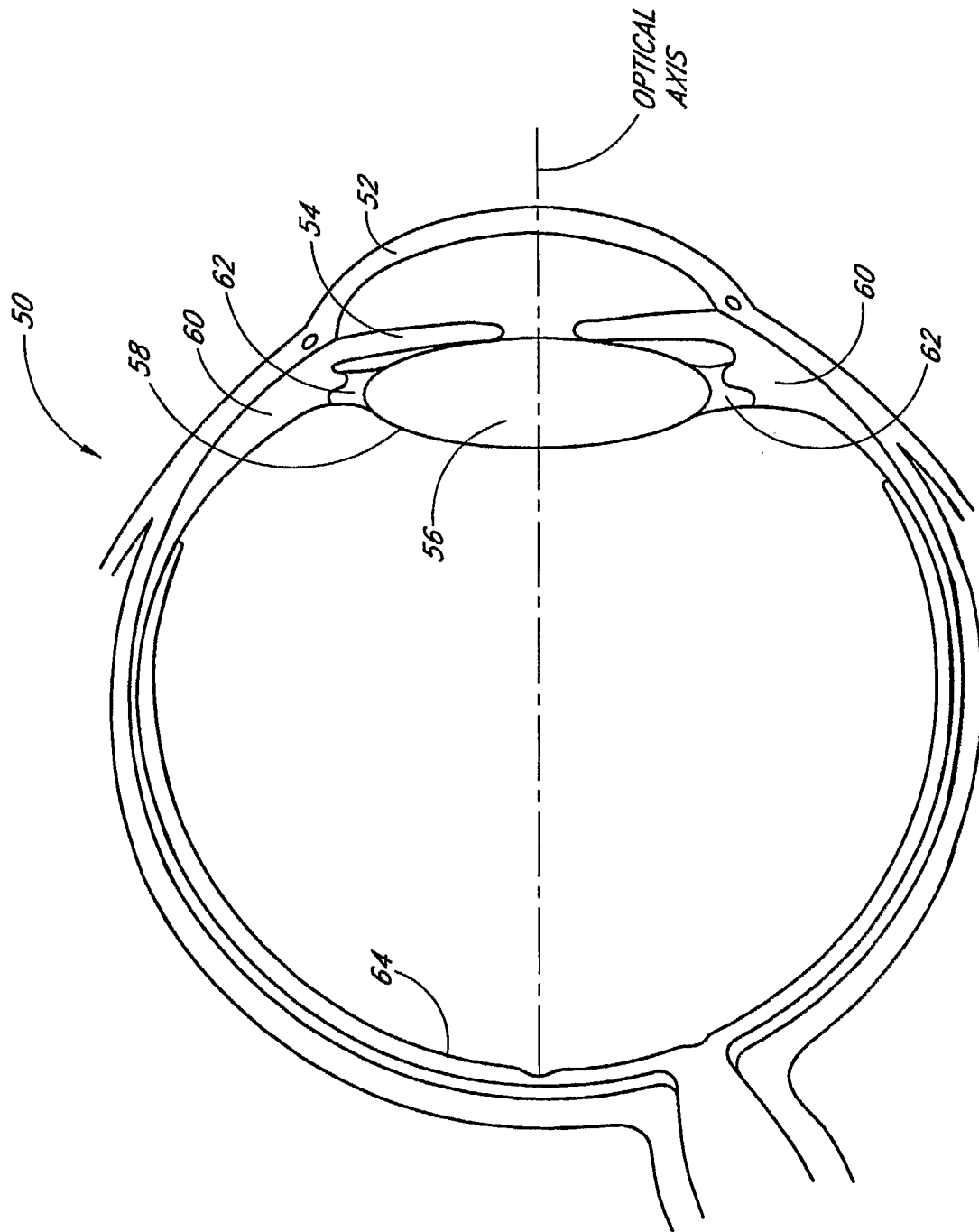
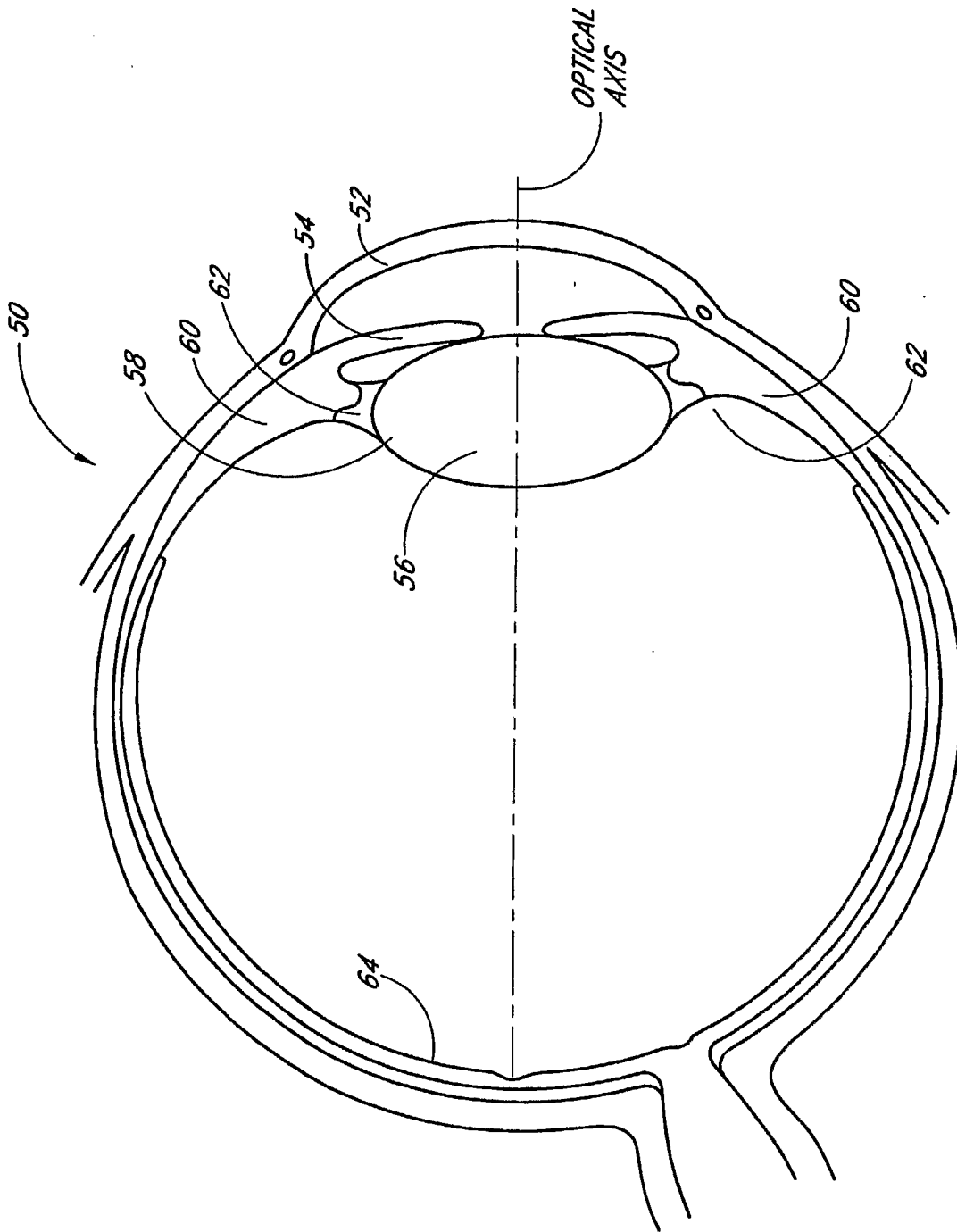

FIG. 1



**FIG. 2**

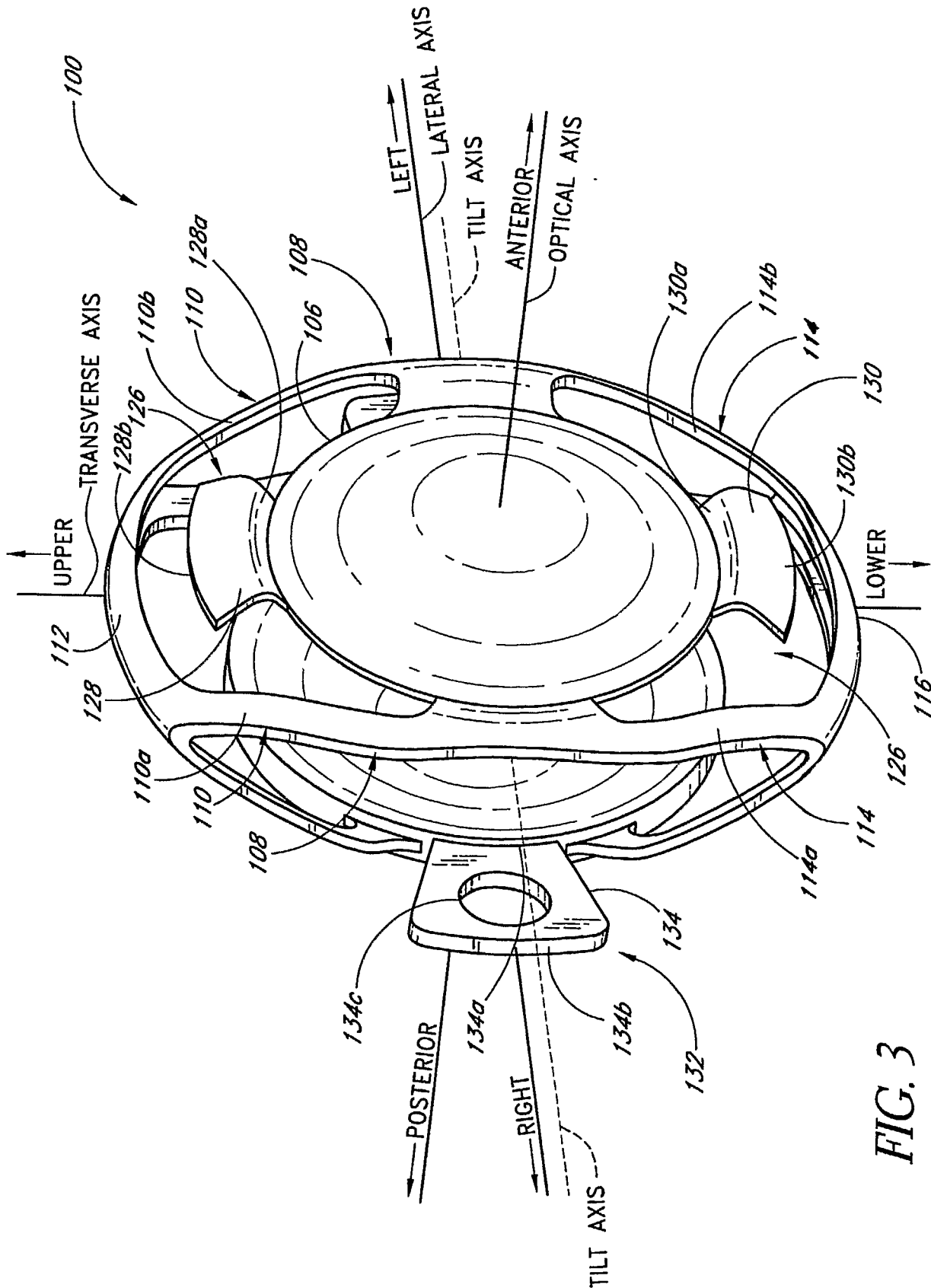

FIG. 3



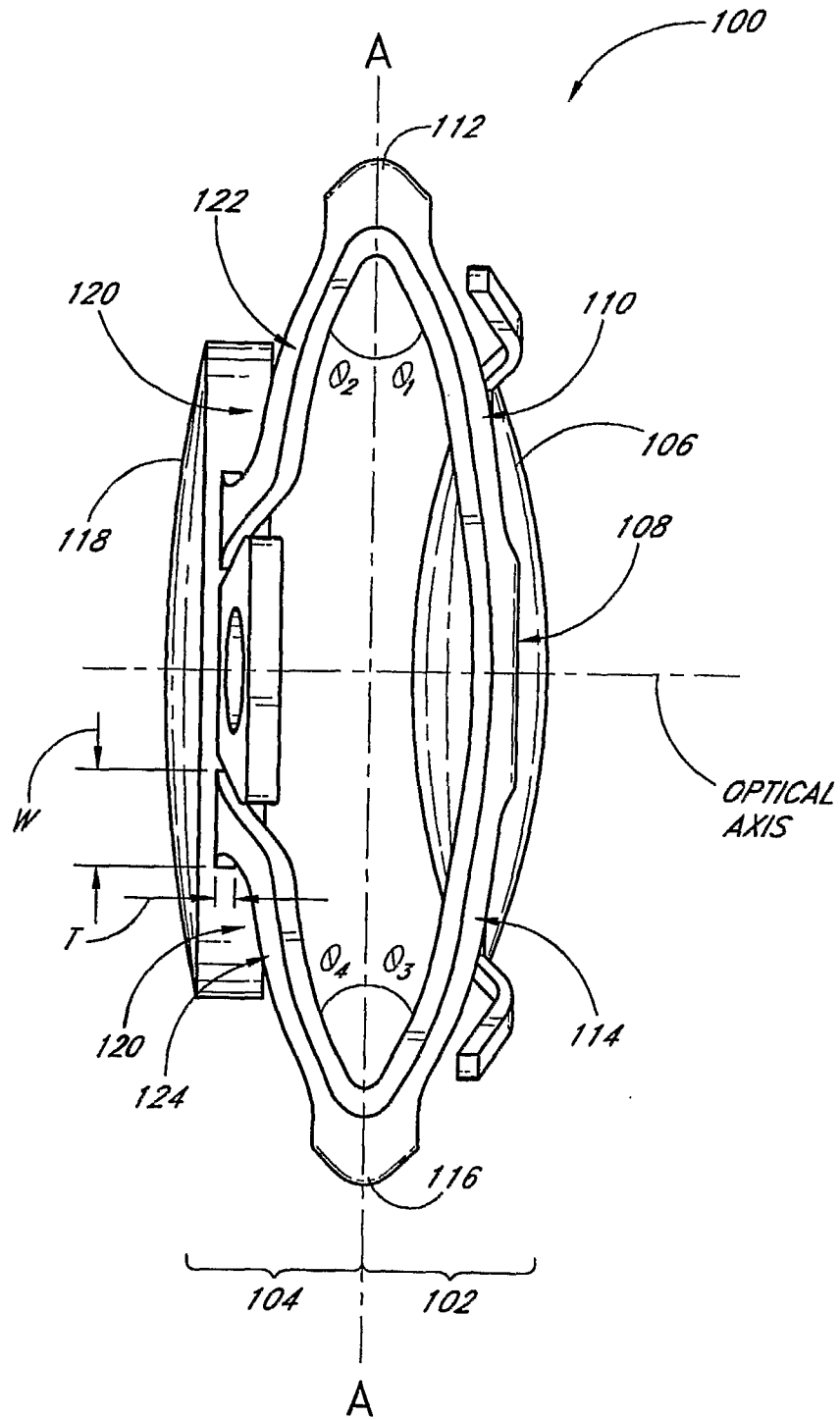
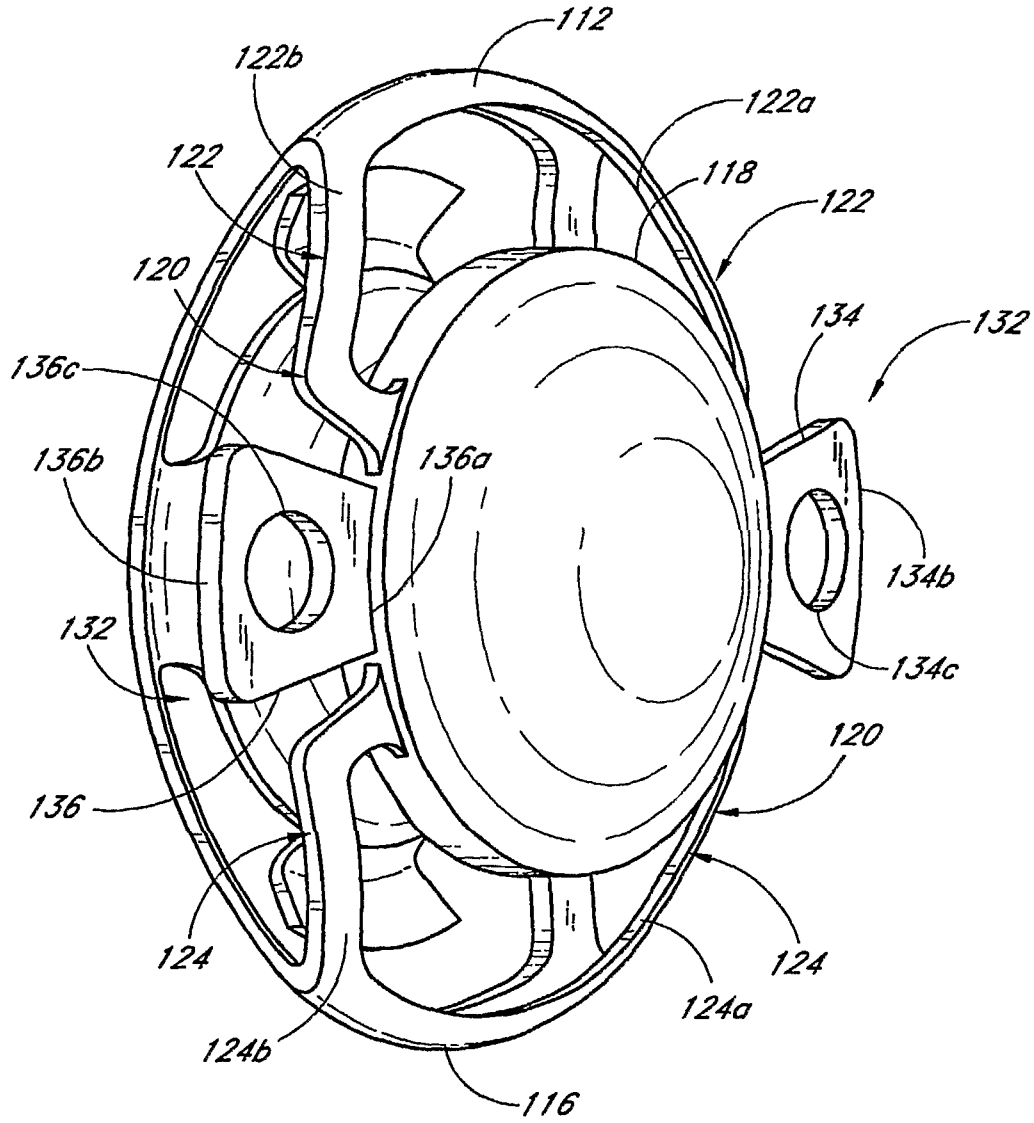

FIG. 4

SUBSTITUTE SHEET (RULE 26)



*FIG. 5*

SUBSTITUTE SHEET (RULE 26)

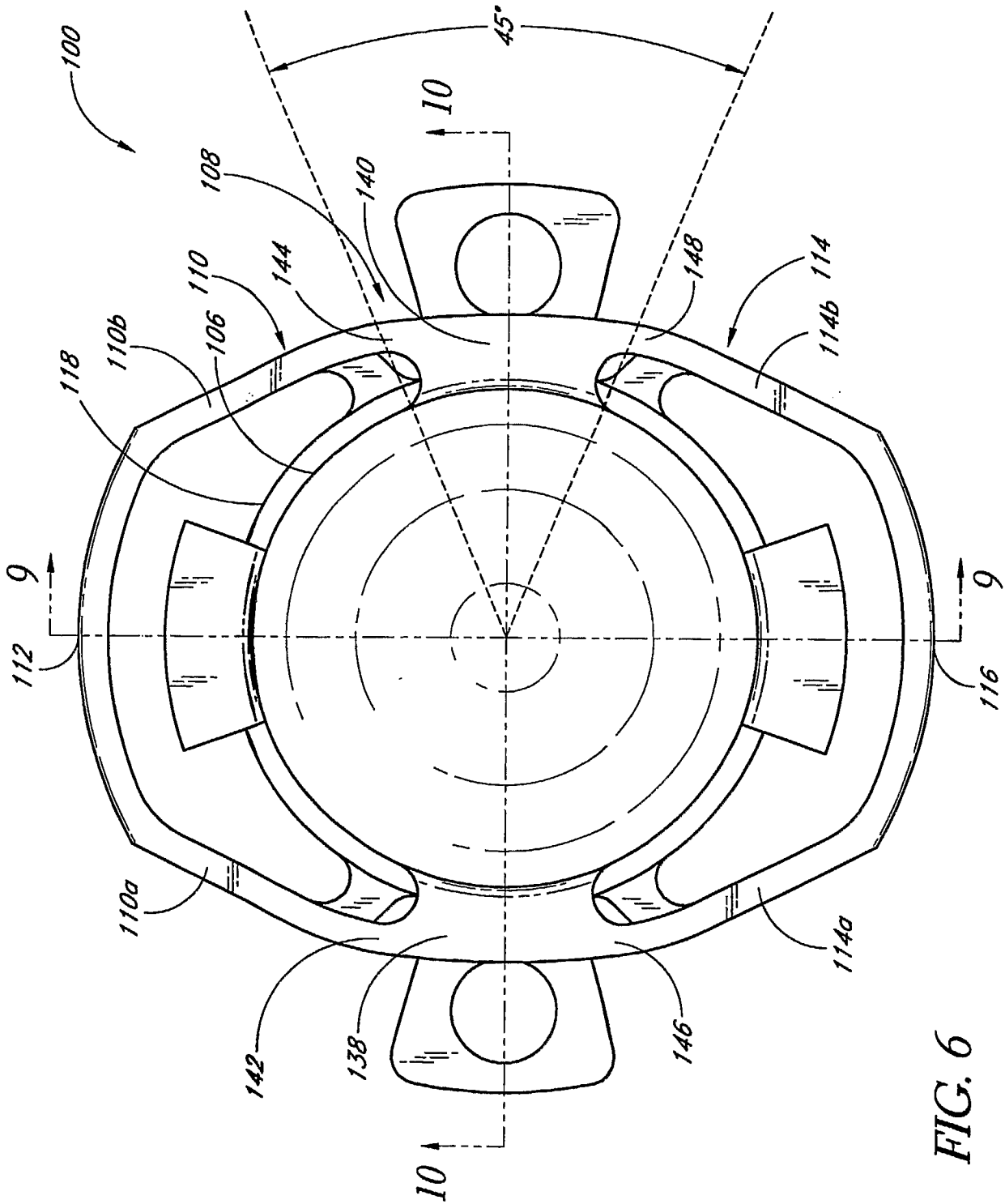

FIG. 6

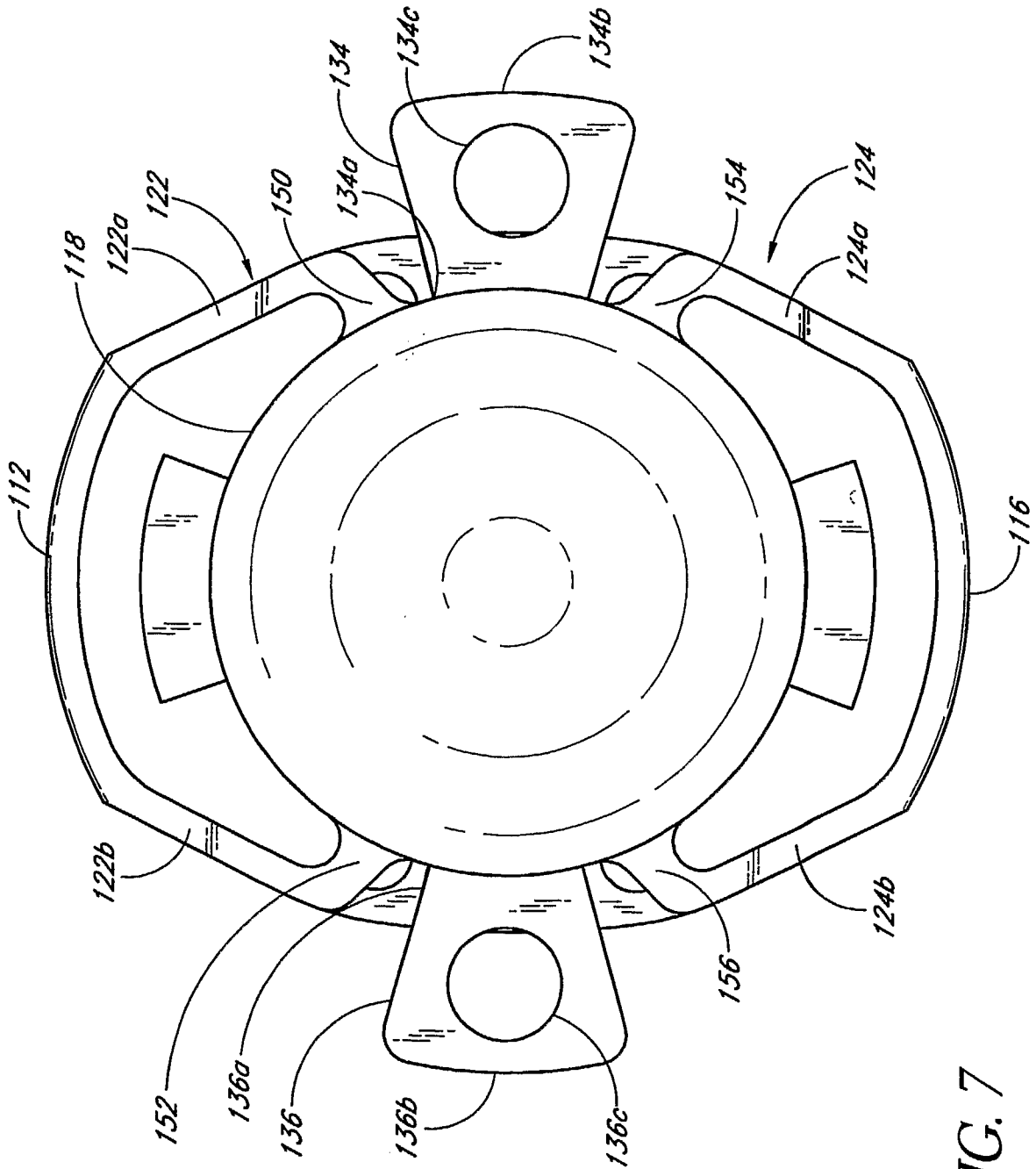

FIG. 7

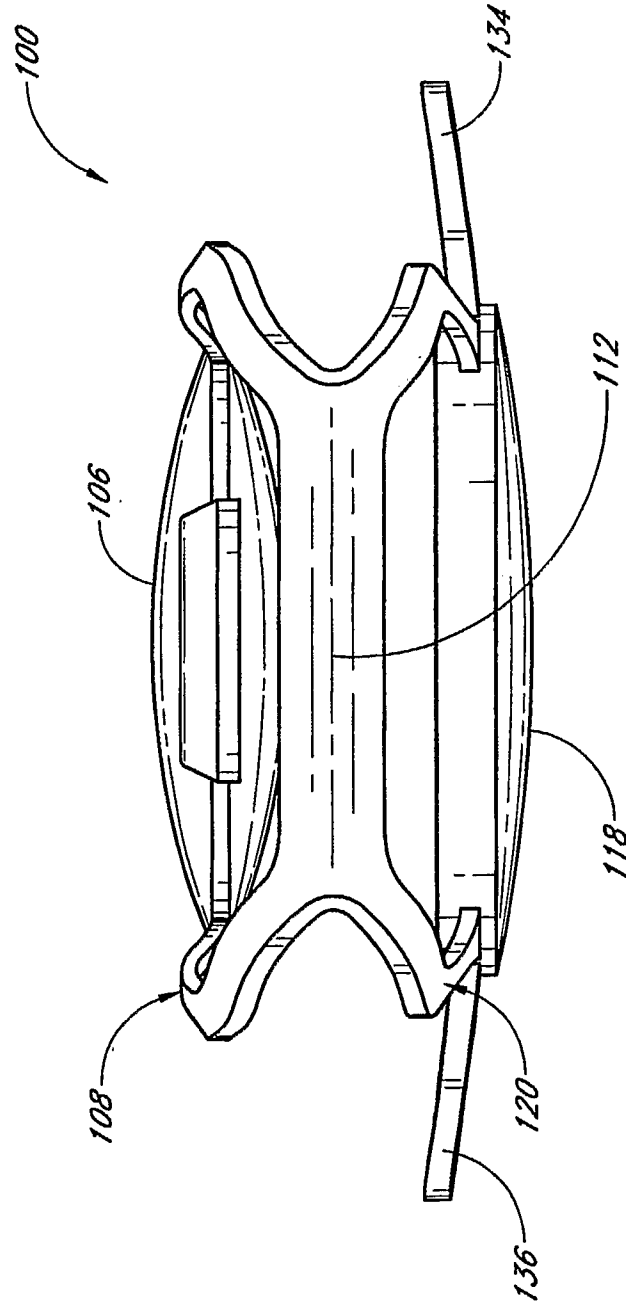

FIG. 8

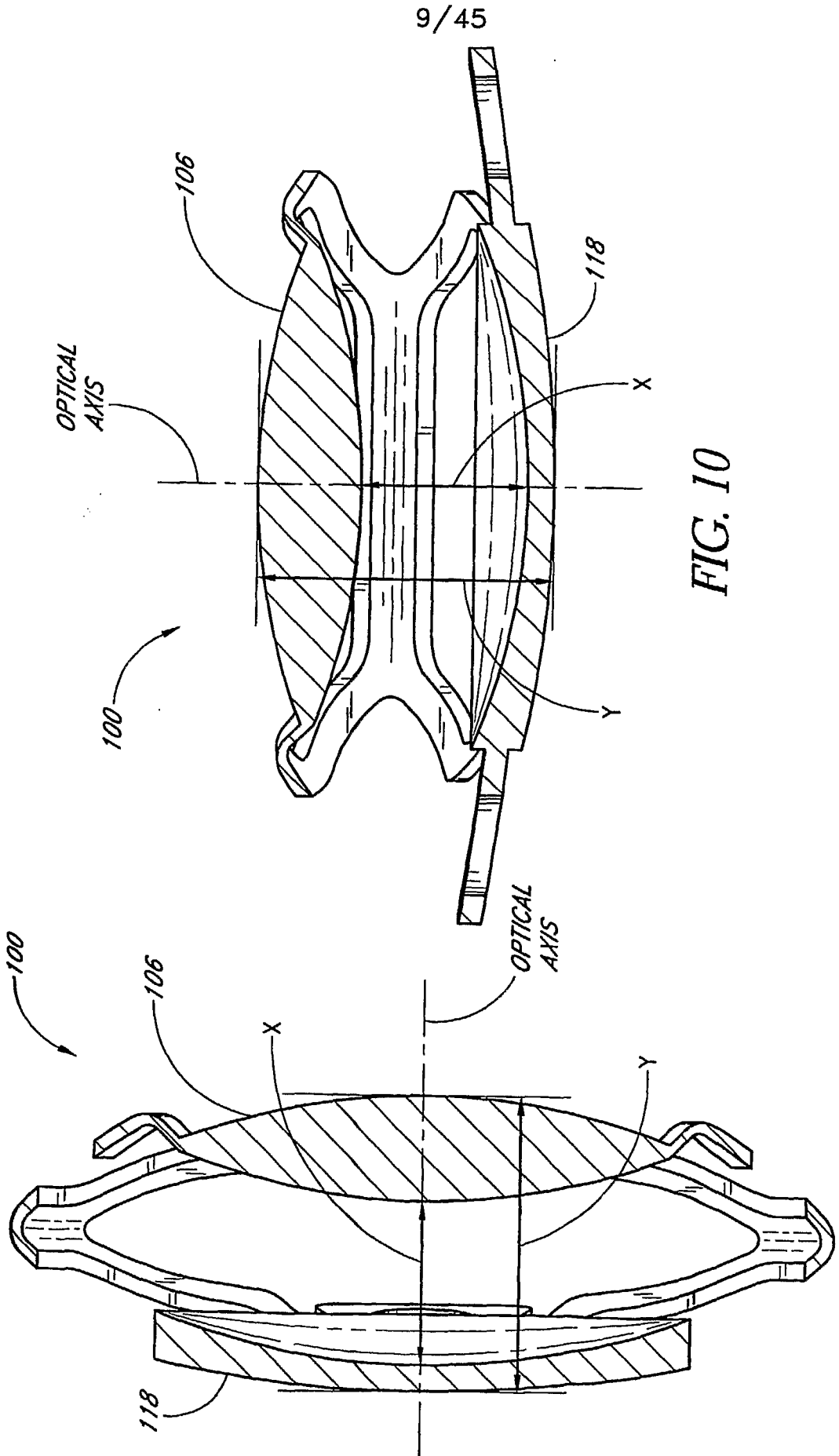

FIG. 10

FIG. 9

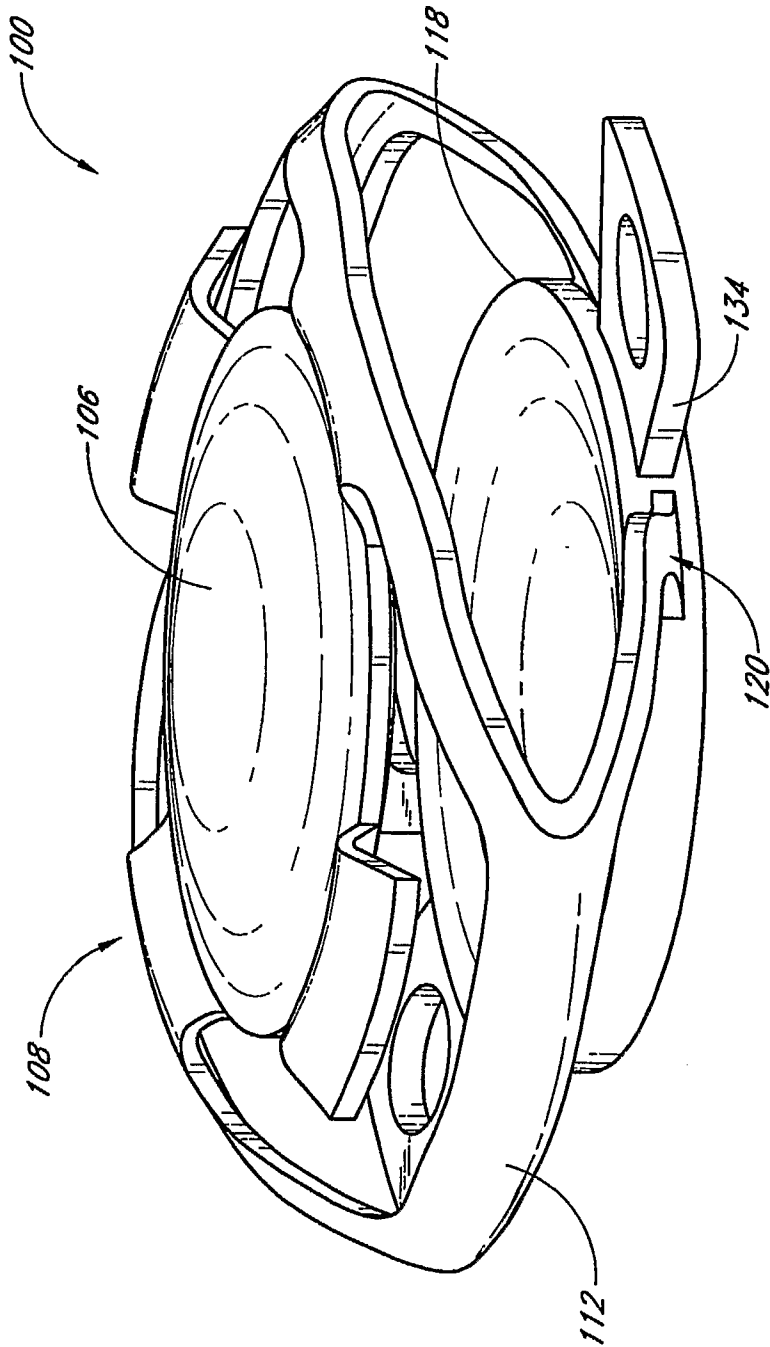

FIG. 11

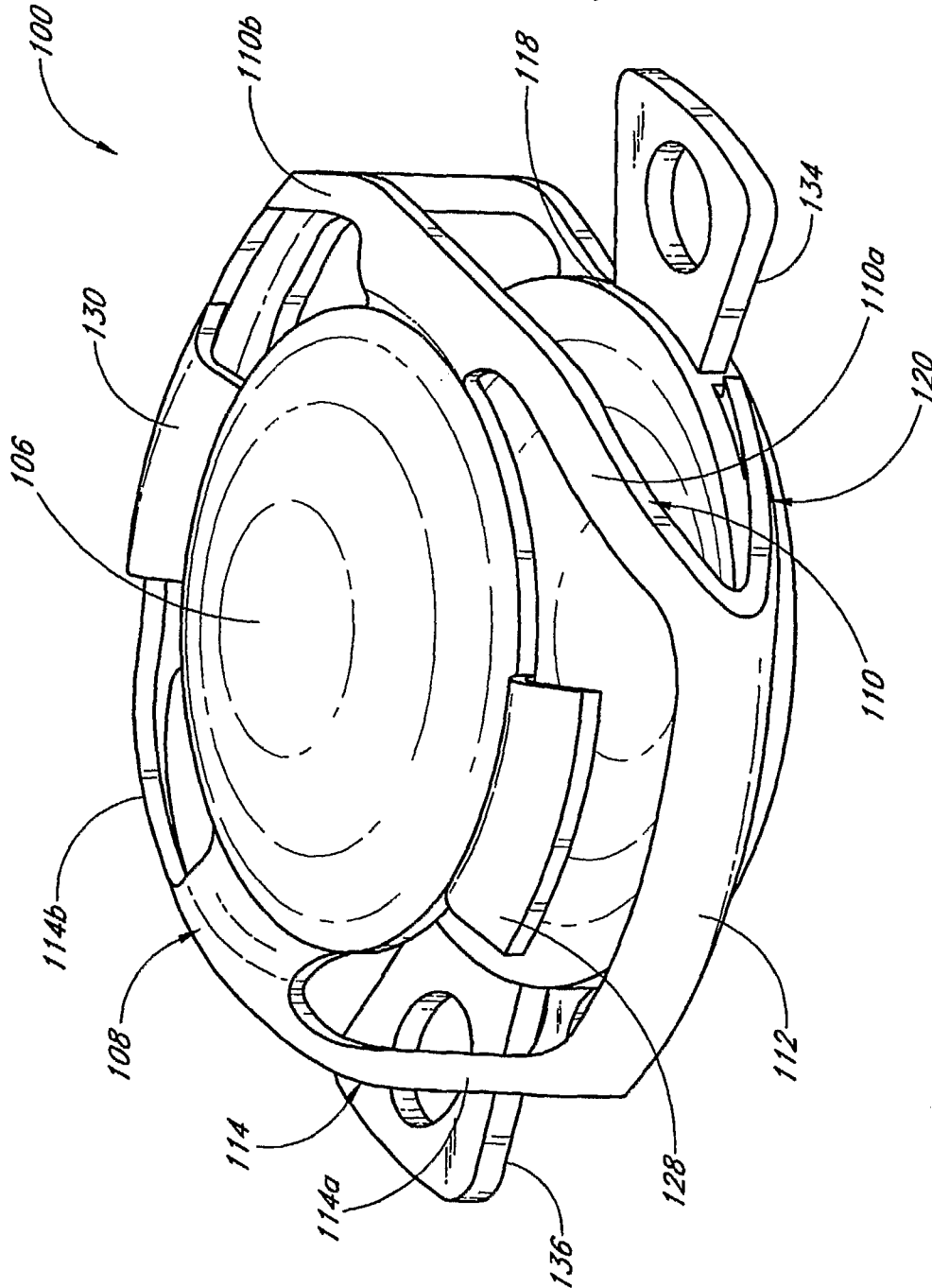

FIG. 12



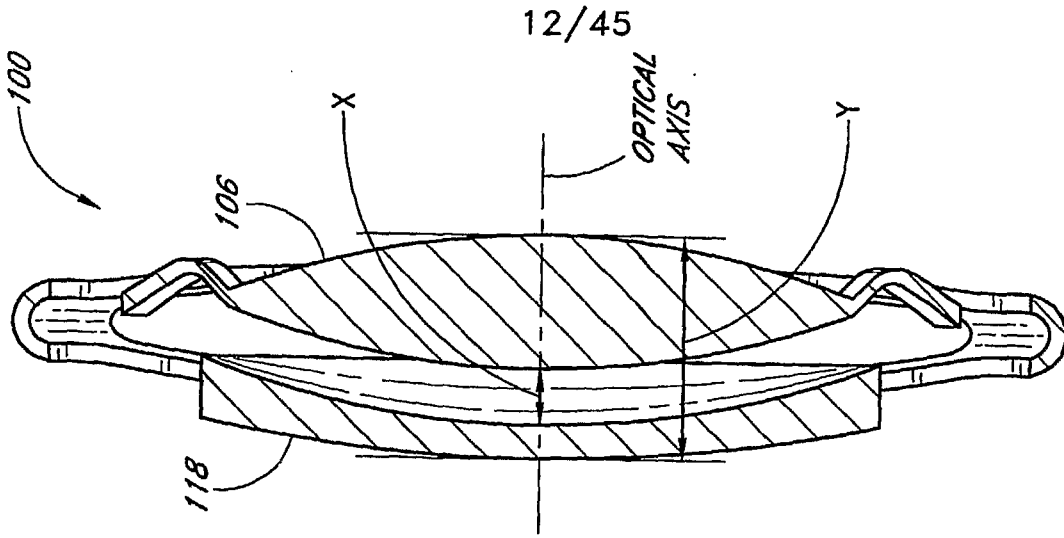

FIG. 14

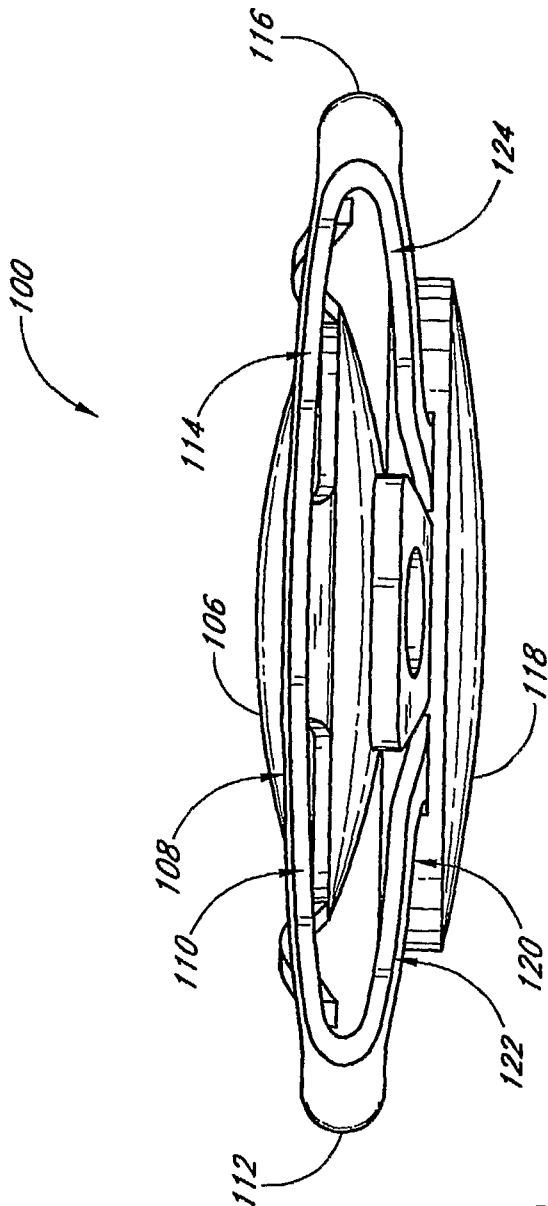

FIG. 13

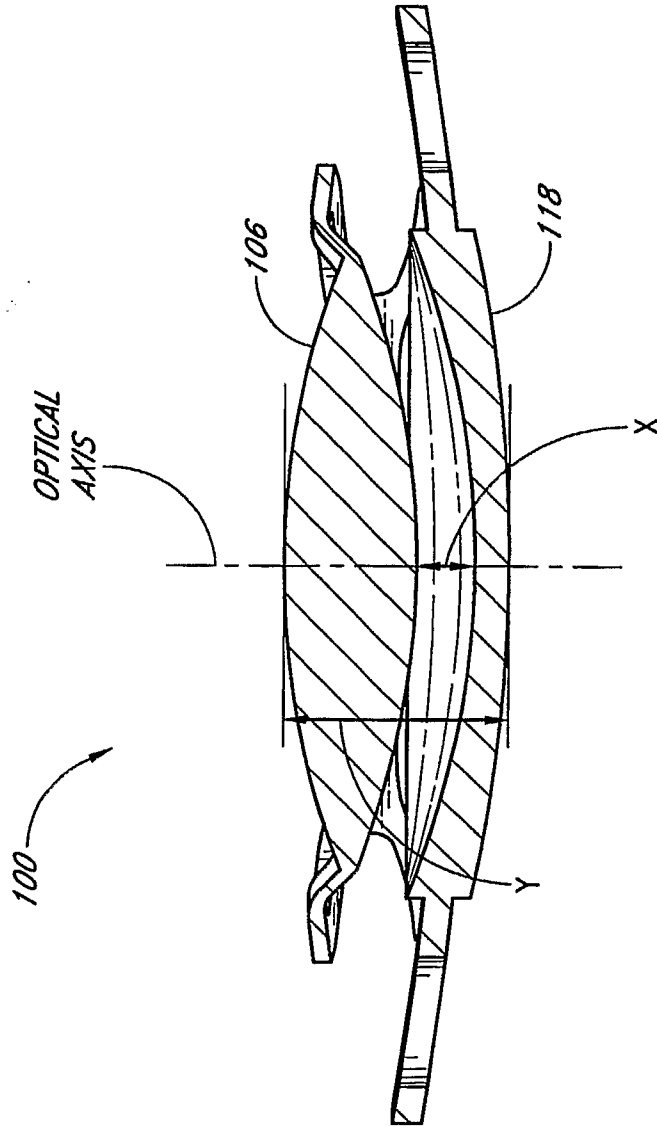

FIG. 15

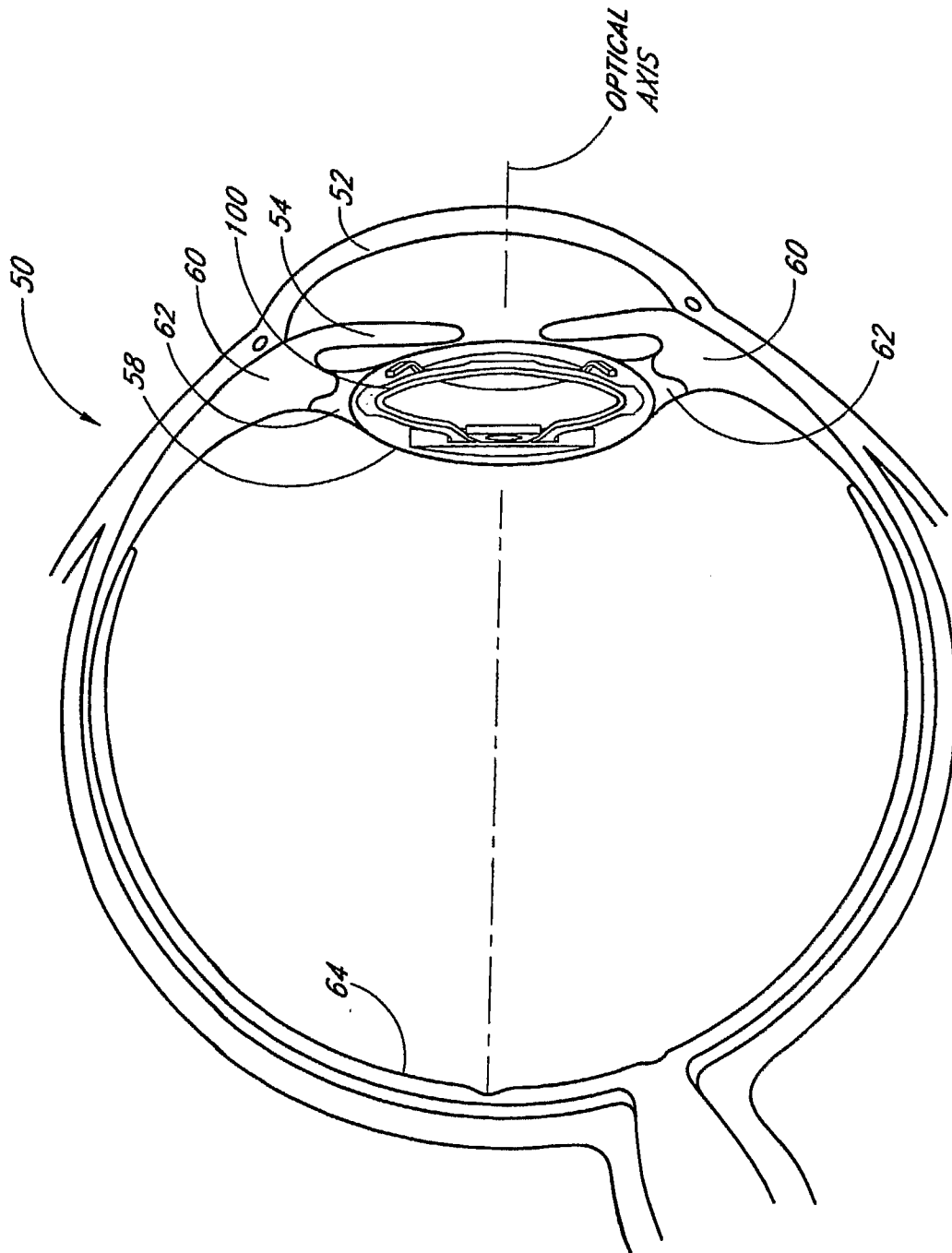
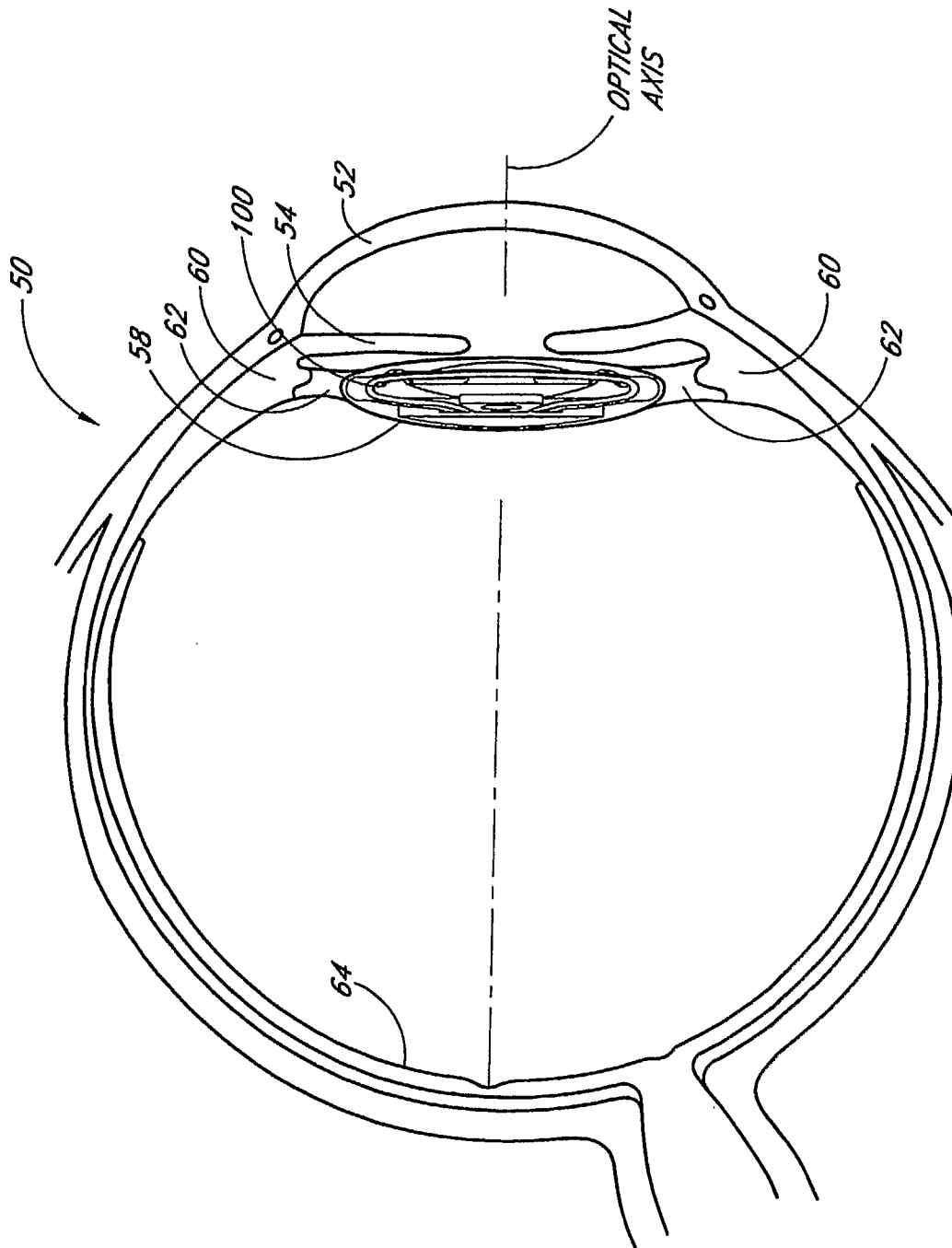
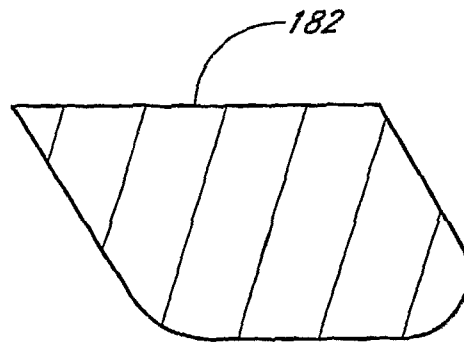

FIG. 16

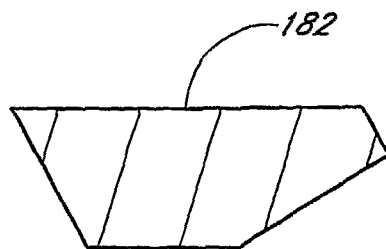

**FIG. 17**

16/45



*FIG. 17A*



*FIG. 17B*

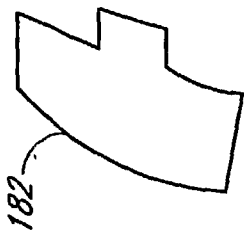

FIG. 17C

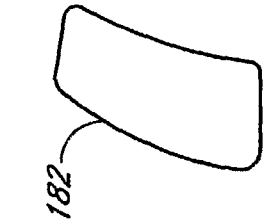

FIG. 17D

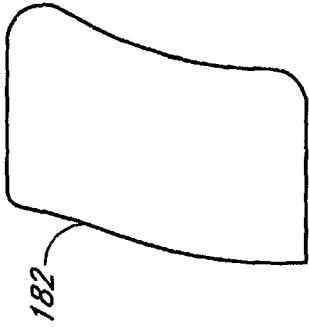

FIG. 17E

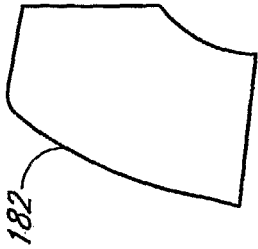

FIG. 17F

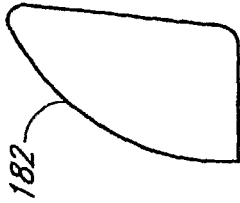

FIG. 17G



FIG. 17H

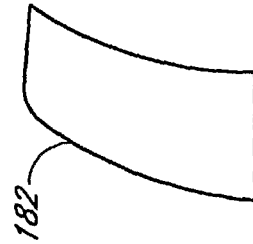

FIG. 17I

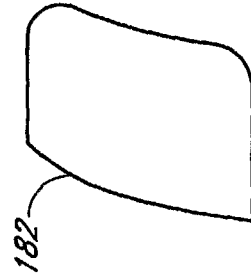

FIG. 17J

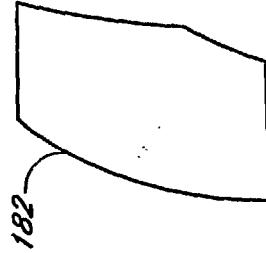

FIG. 17K

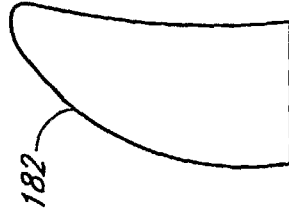
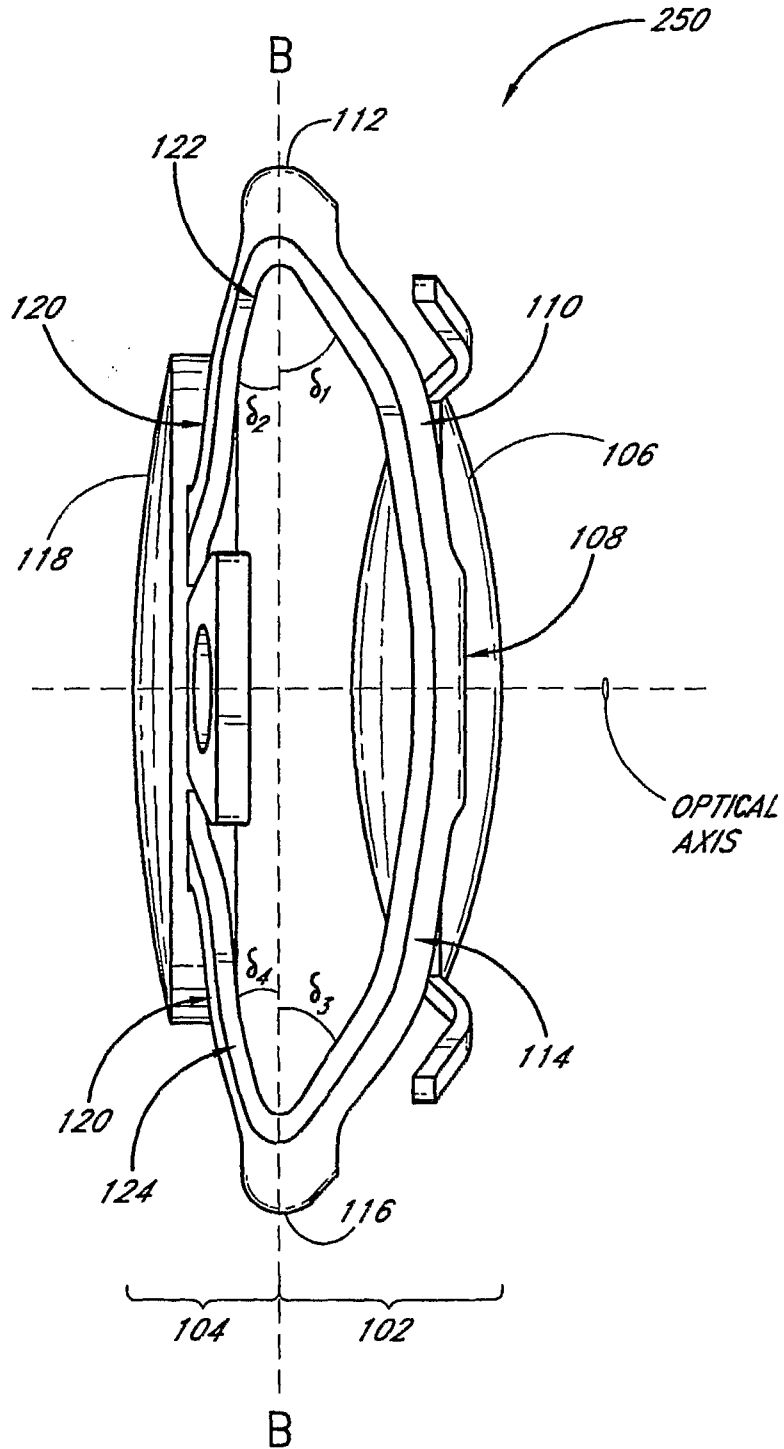
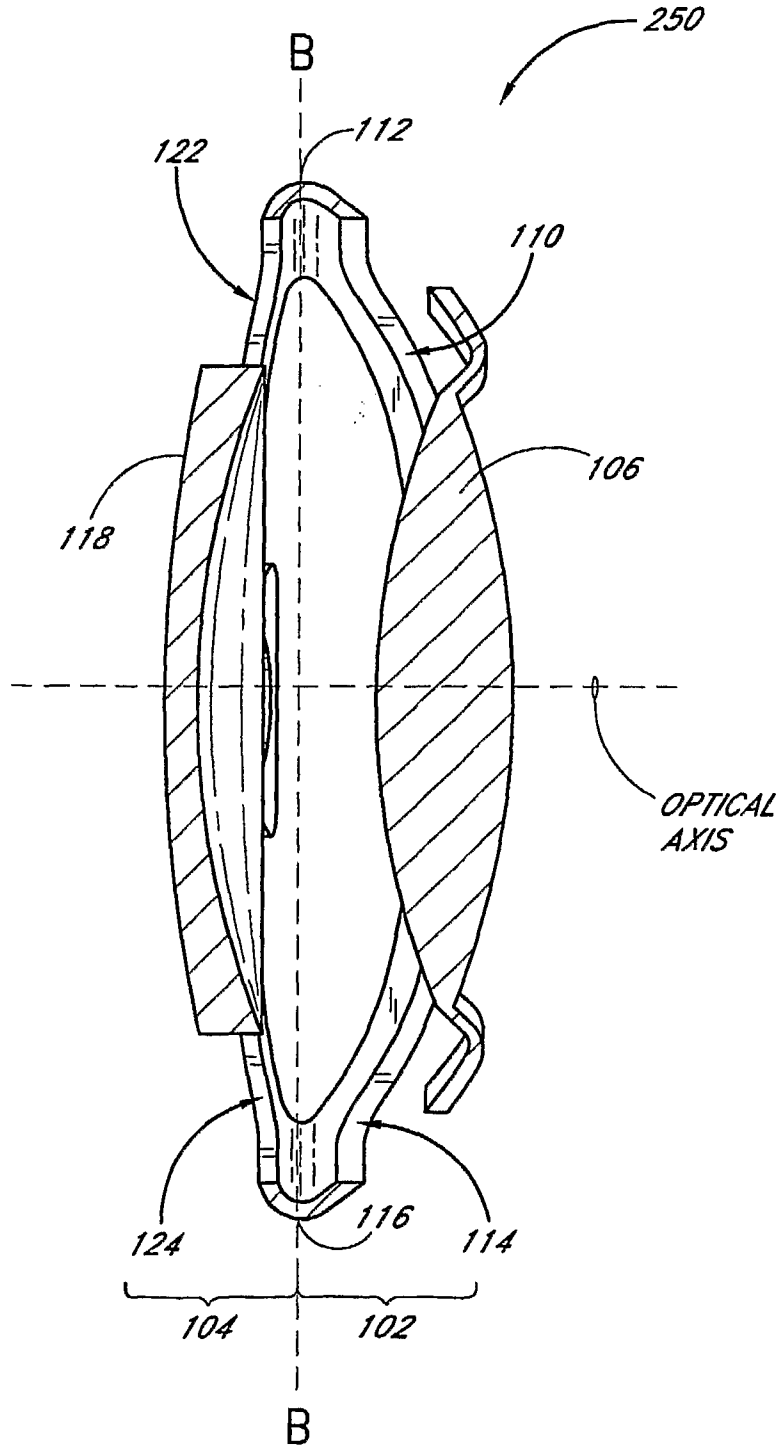

FIG. 17L



**FIG. 17M**  
**SUBSTITUTE SHEET (RULE 26)**

19/45



**FIG. 17N**  
**SUBSTITUTE SHEET (RULE 26)**



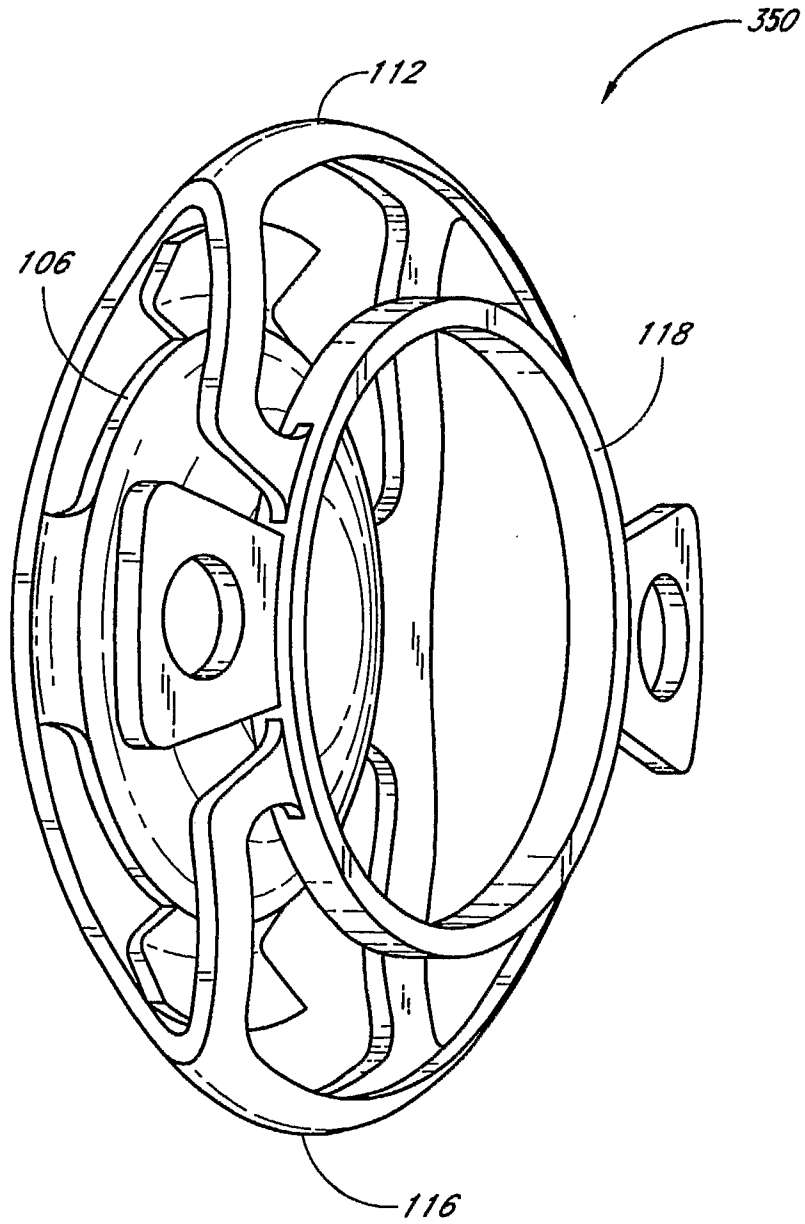

**FIG. 17P**  
**SUBSTITUTE SHEET (RULE 26)**

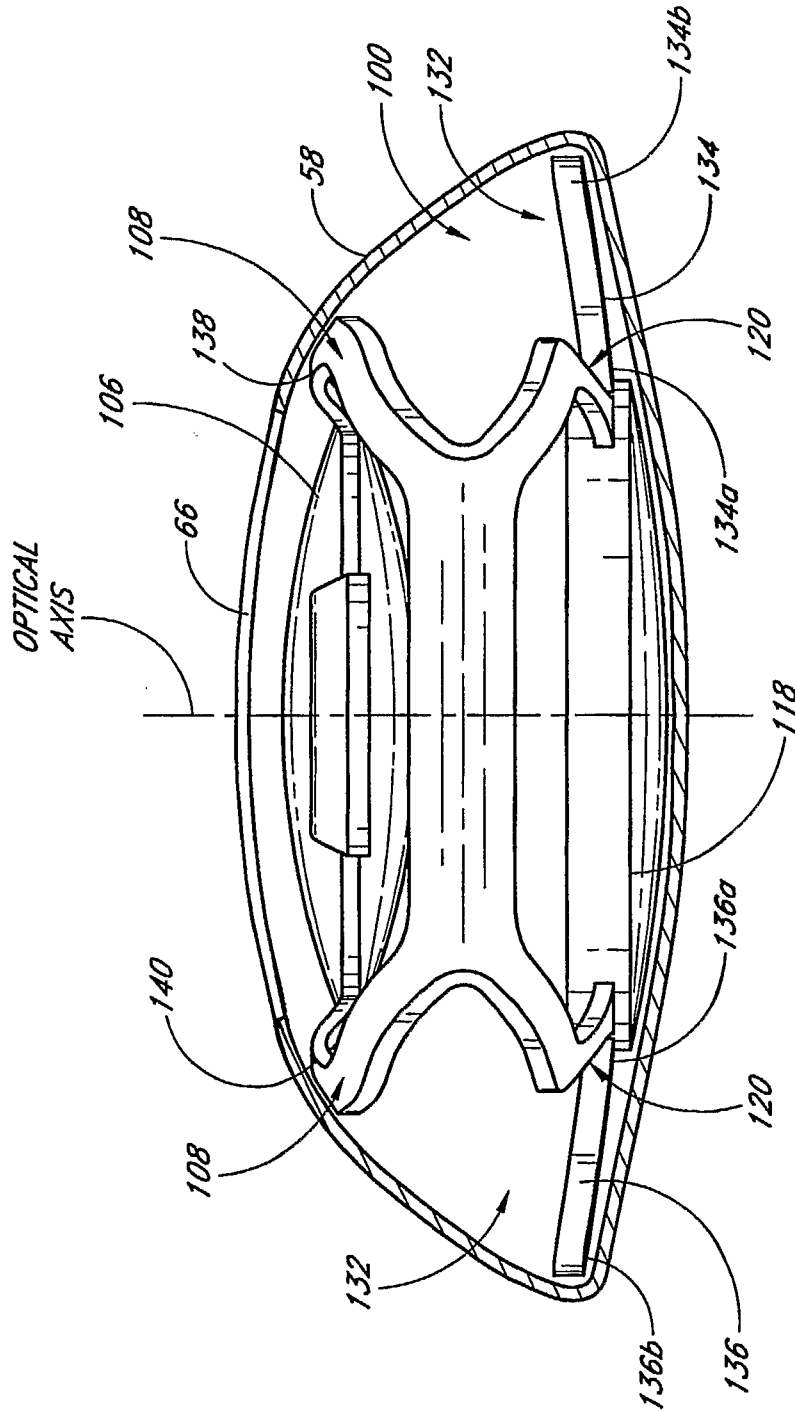

FIG. 18

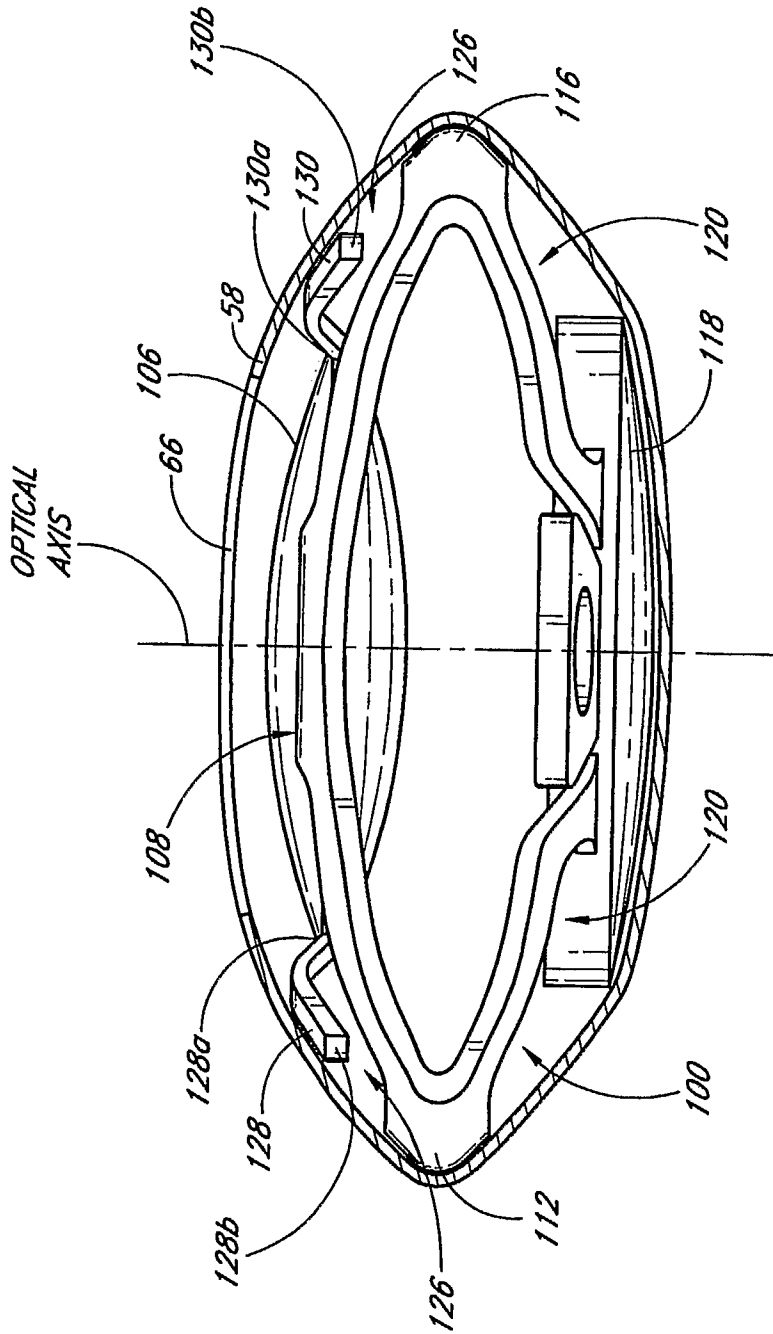

FIG. 19

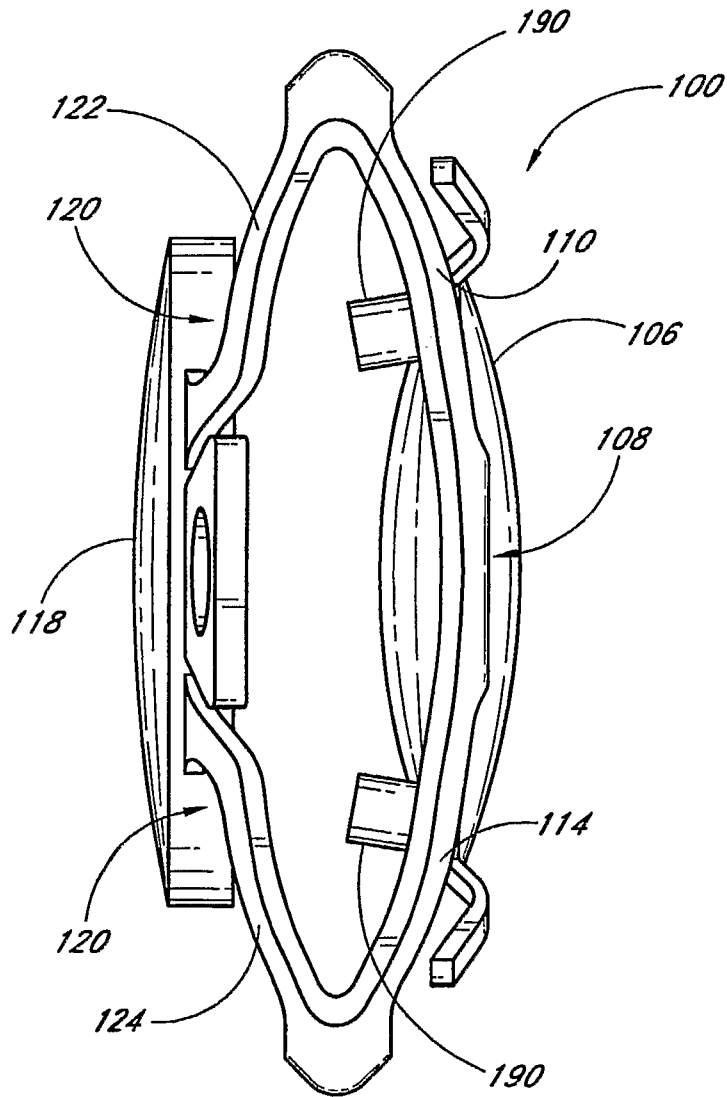
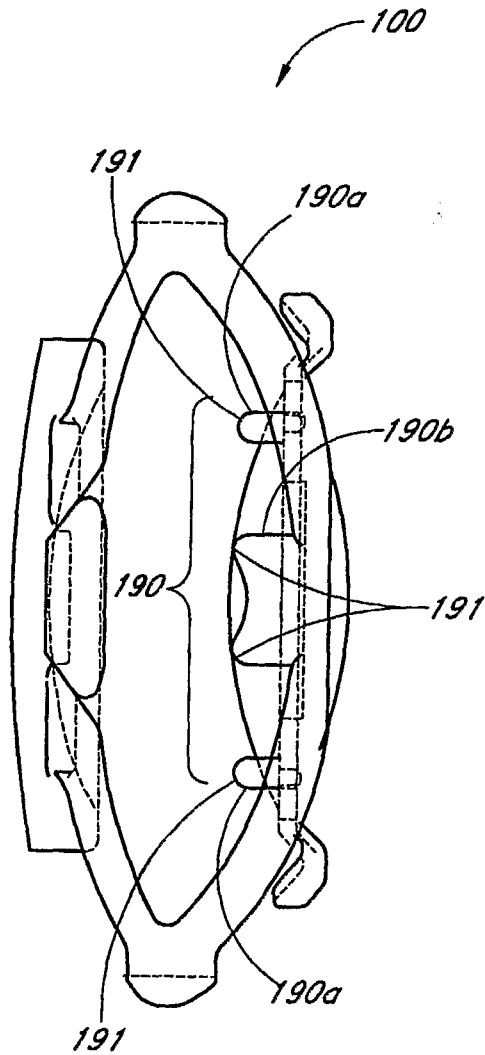
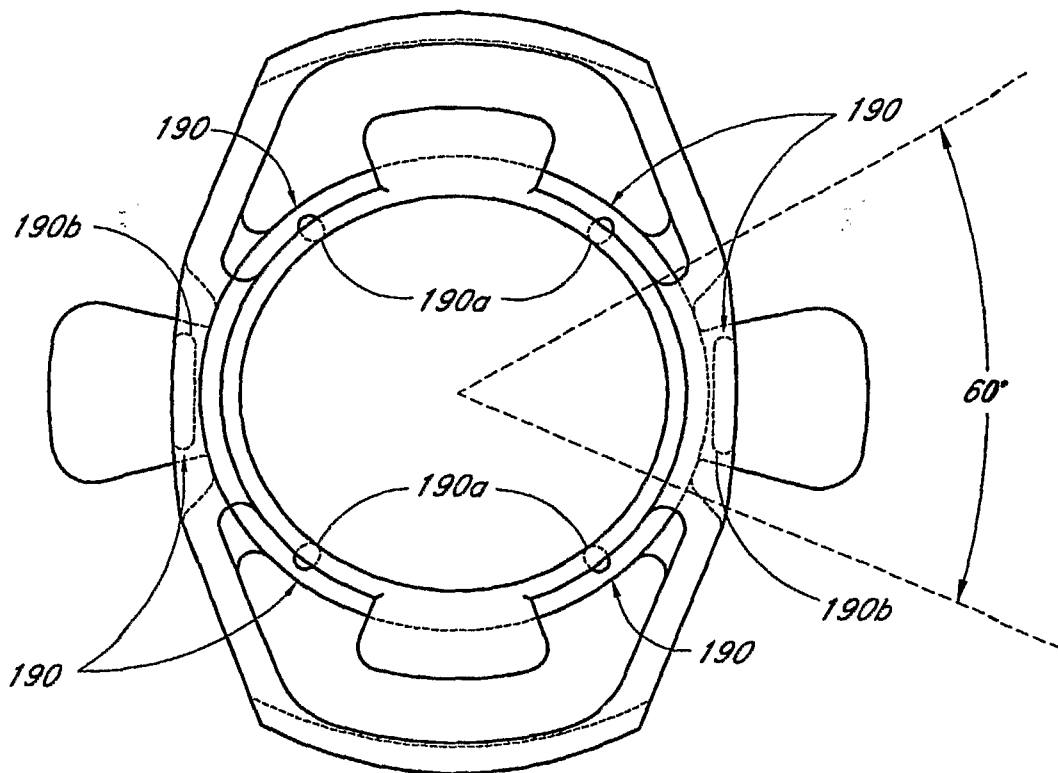

FIG. 20



*FIG. 21*



*FIG. 22*

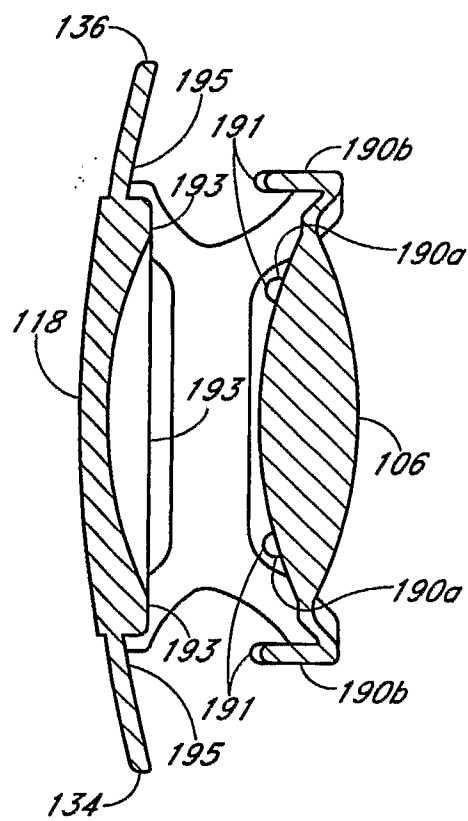

FIG. 23

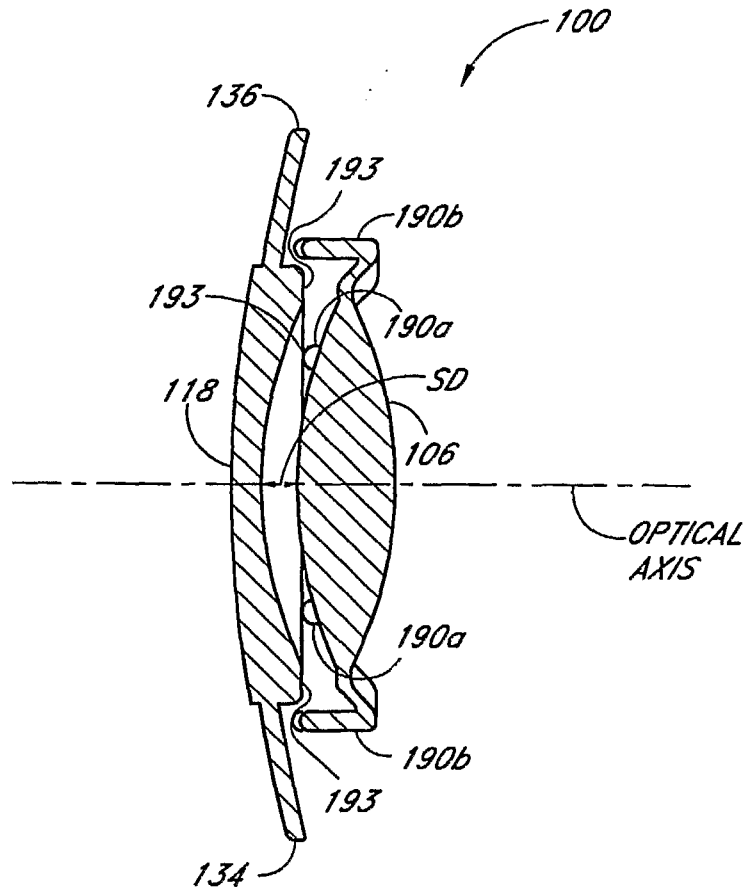
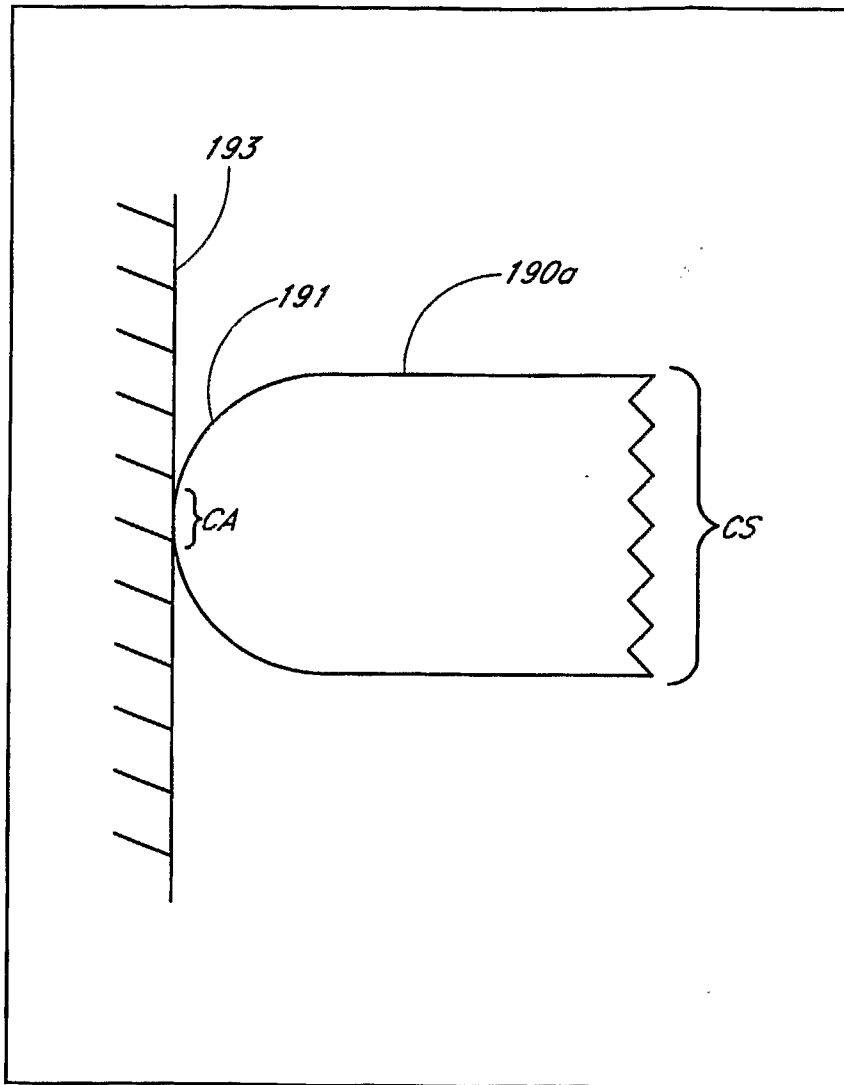

FIG. 24





*FIG. 25*

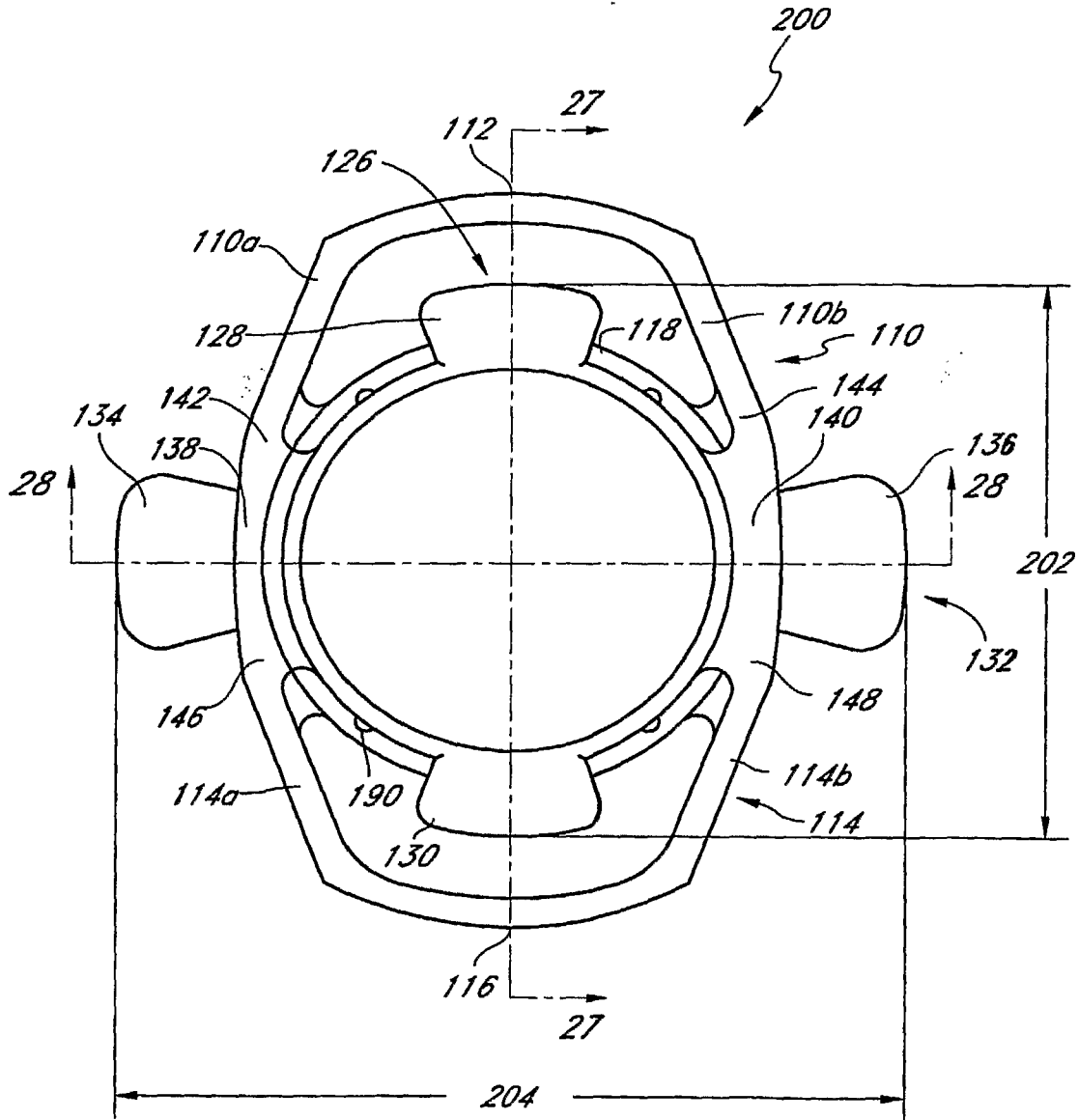

FIG. 26

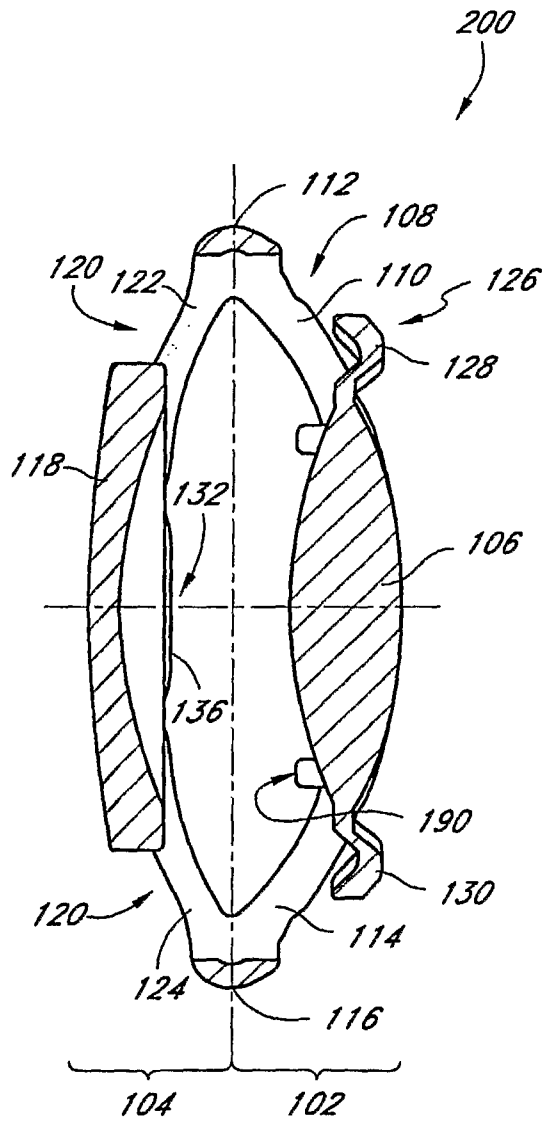

FIG. 27

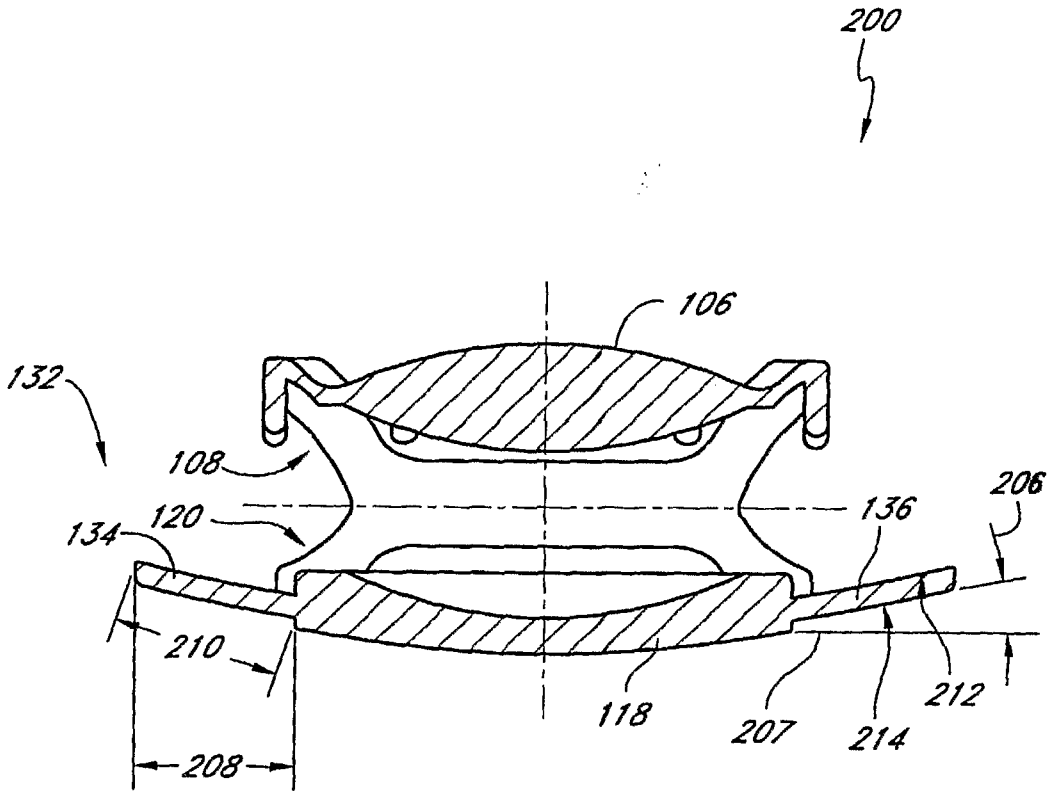

FIG. 28



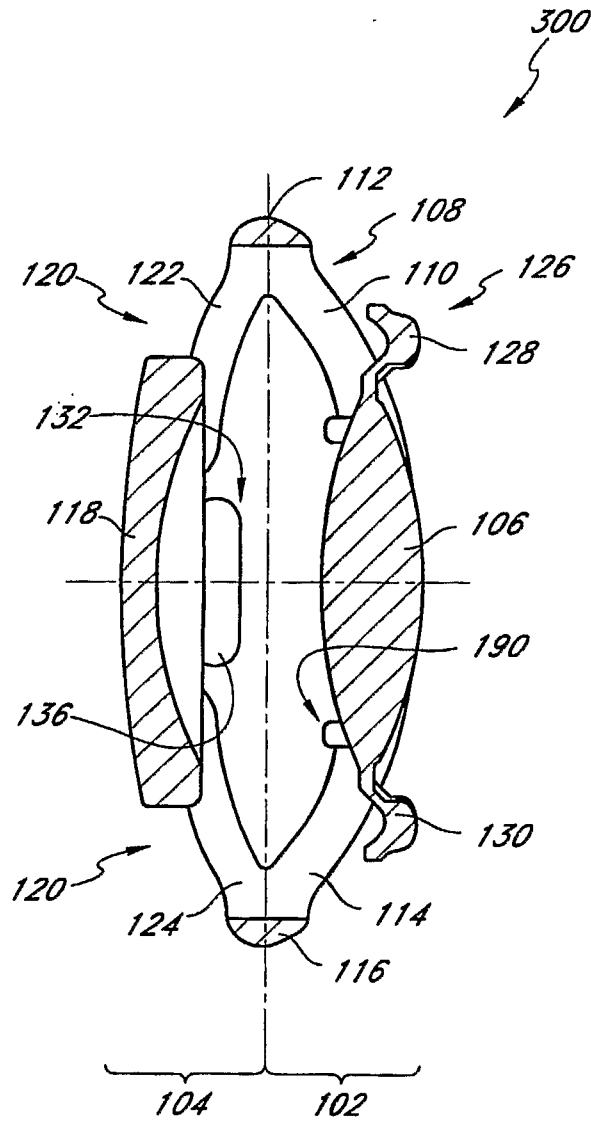

FIG. 30

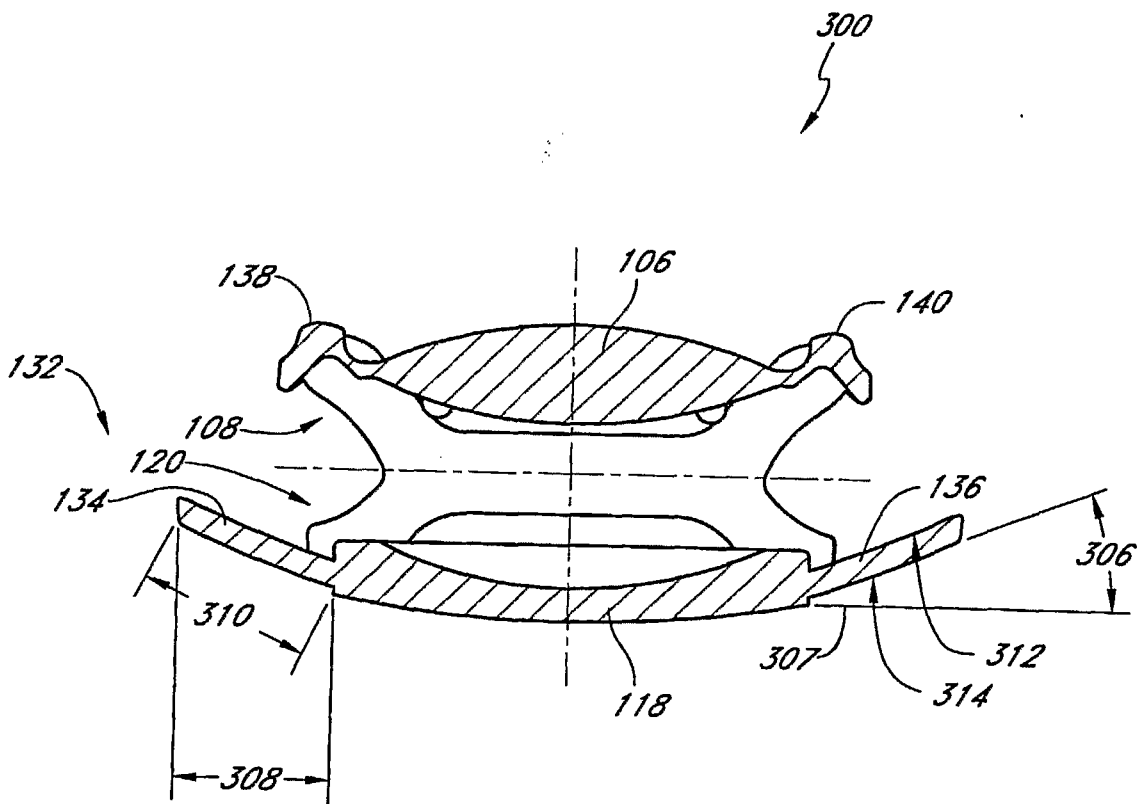

FIG. 31

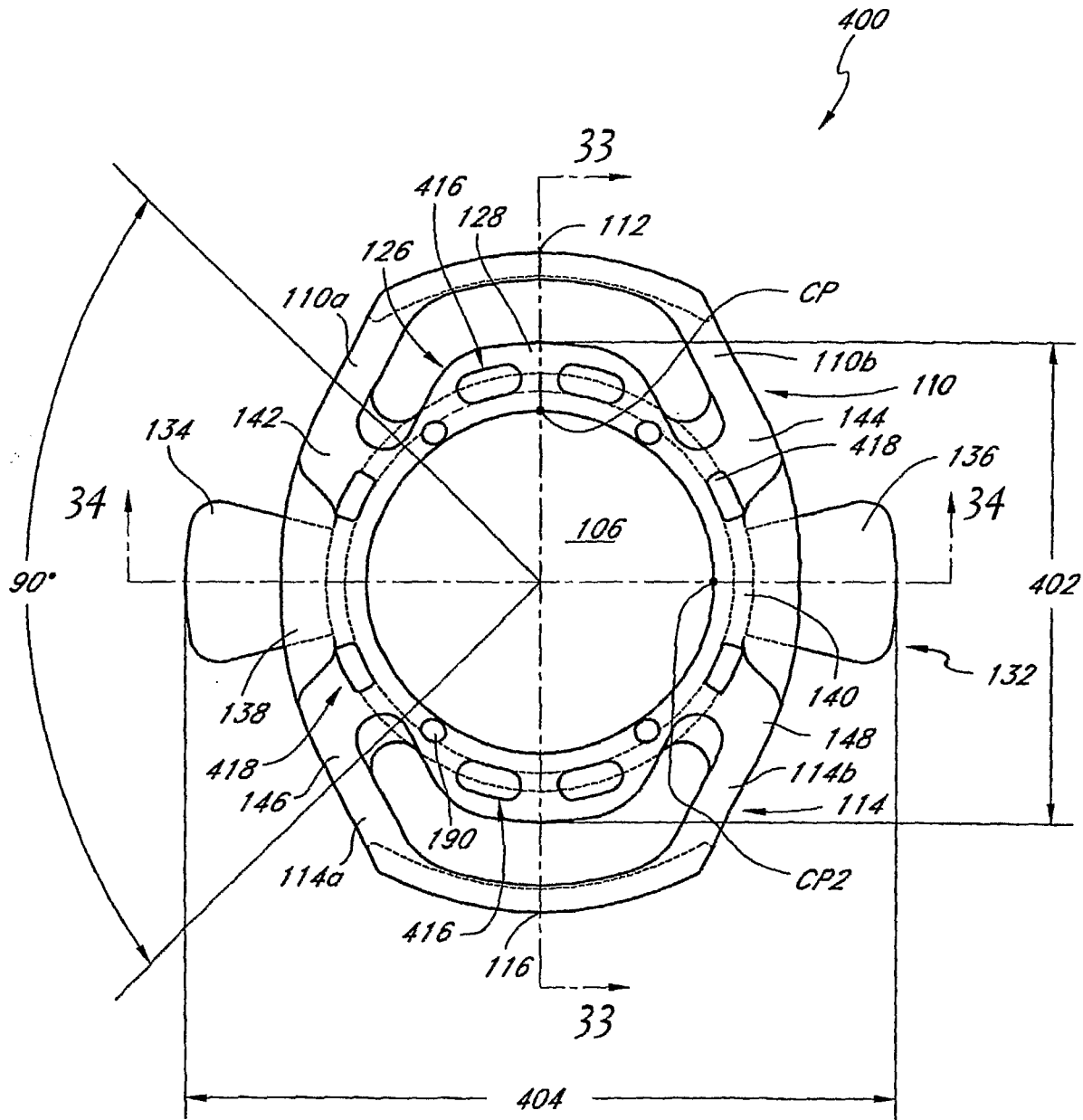

FIG. 32



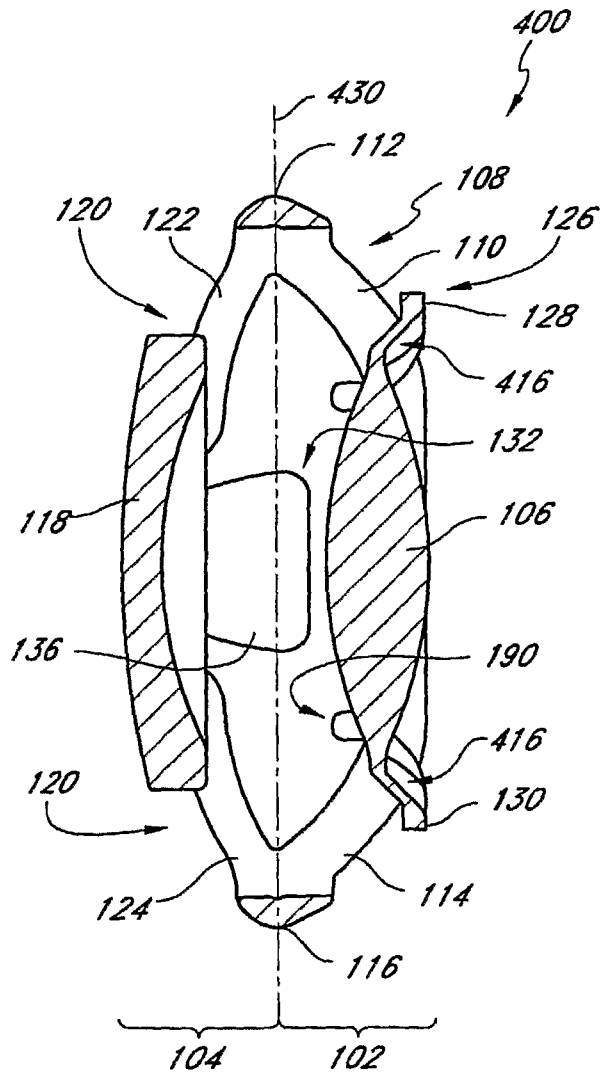

FIG. 33

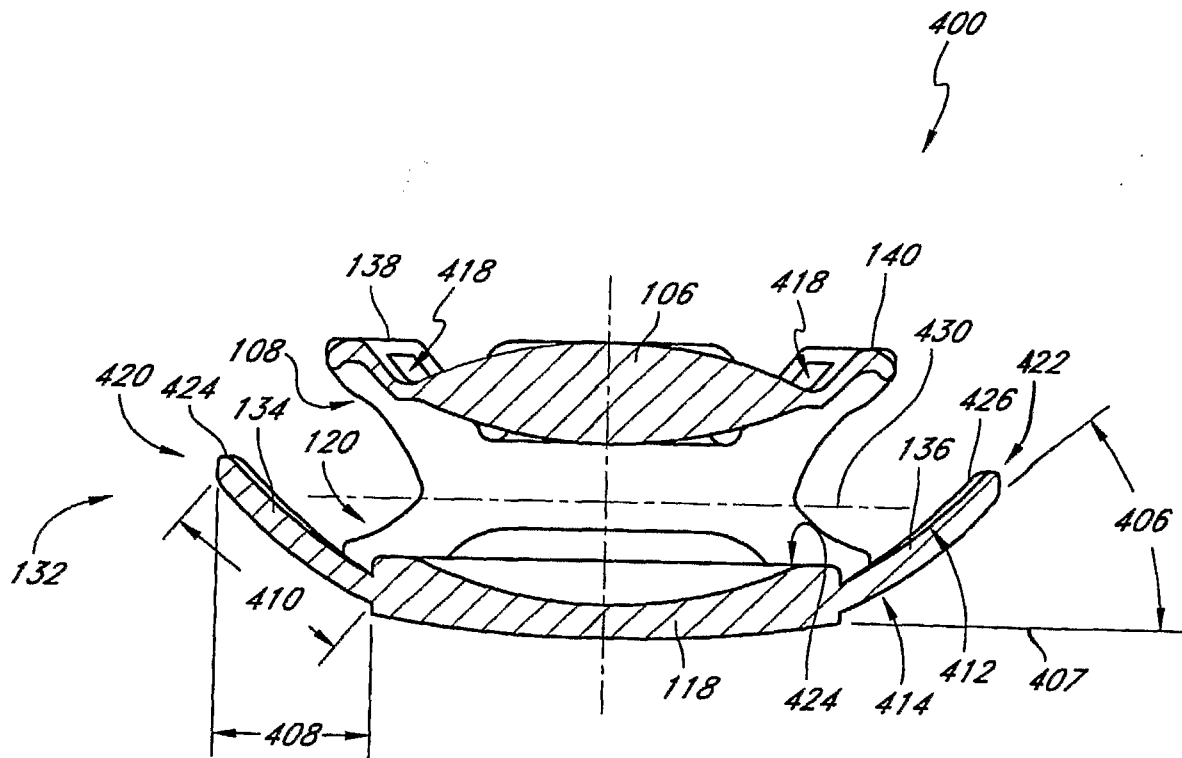

FIG. 34

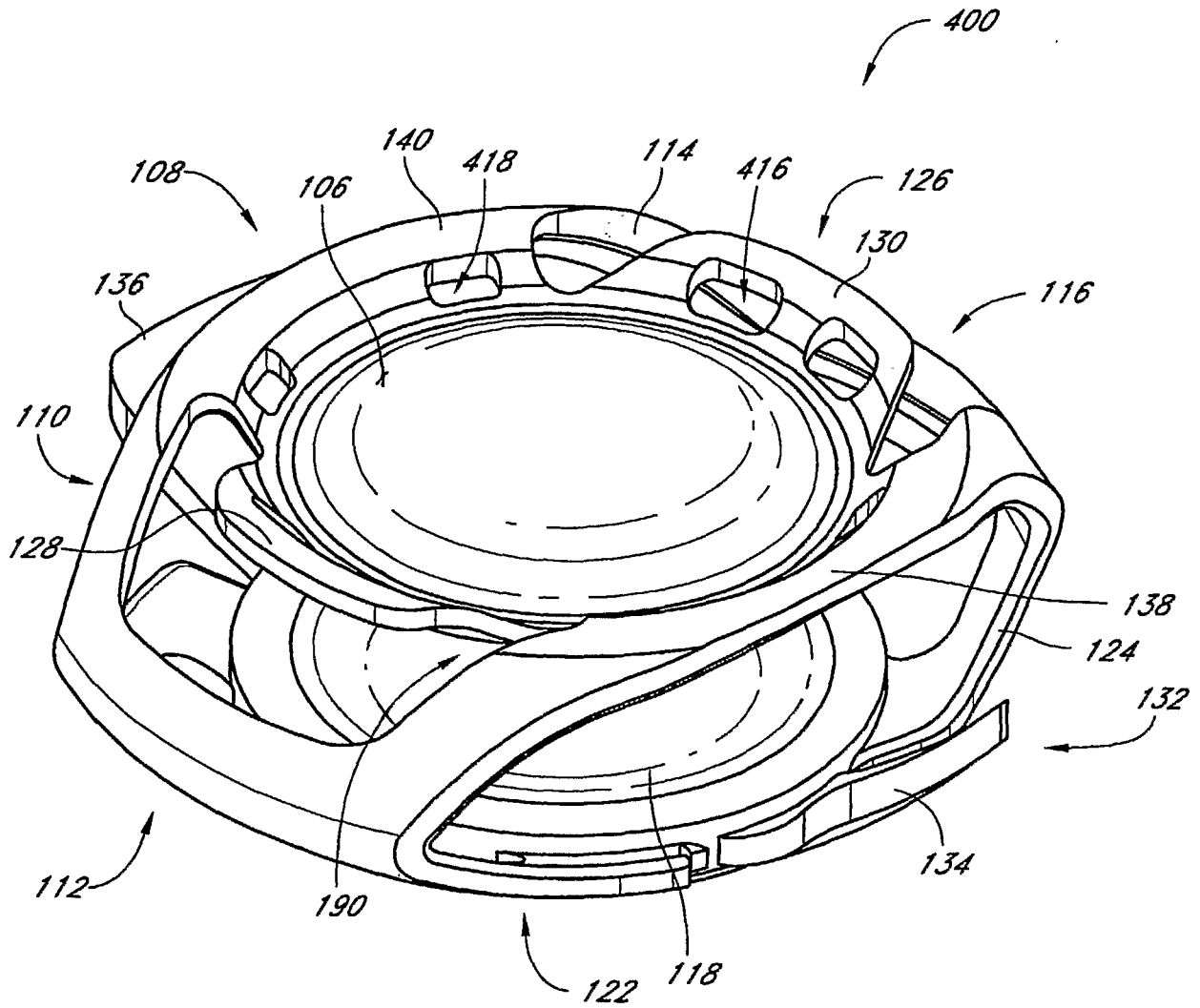

FIG. 35

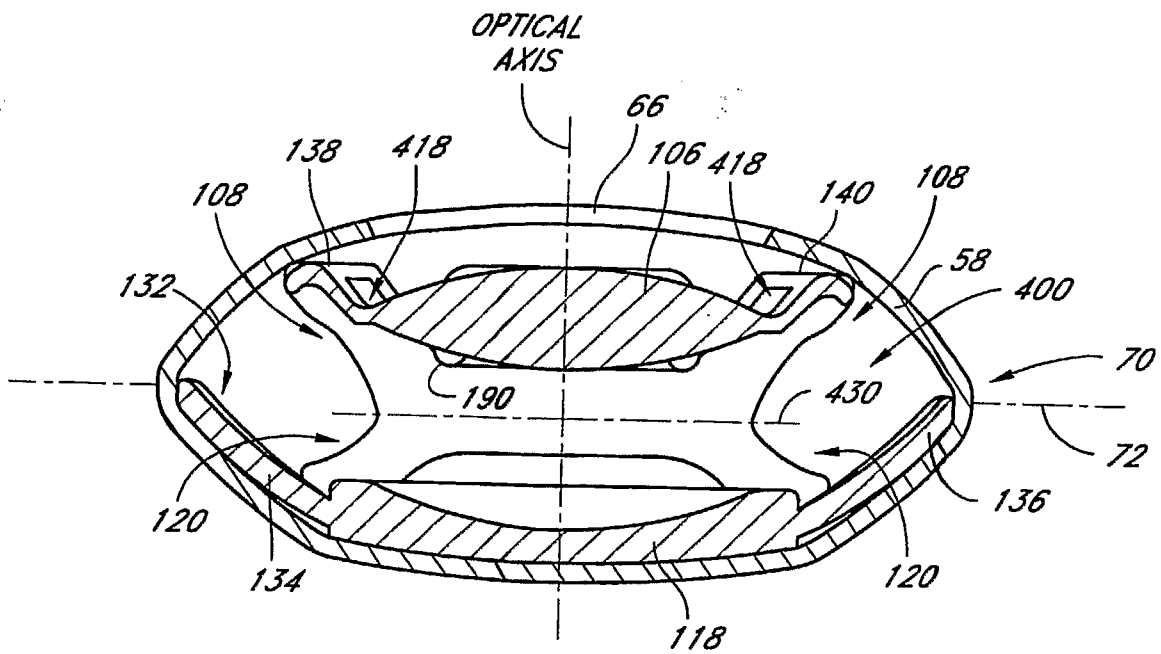

FIG. 36

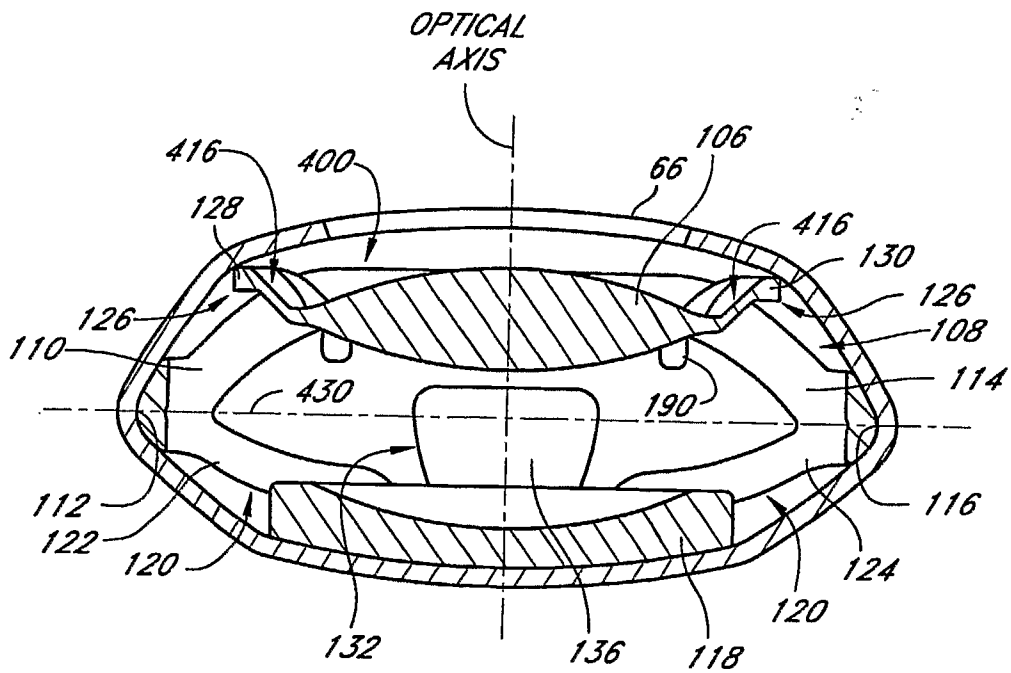

FIG. 37

41/45

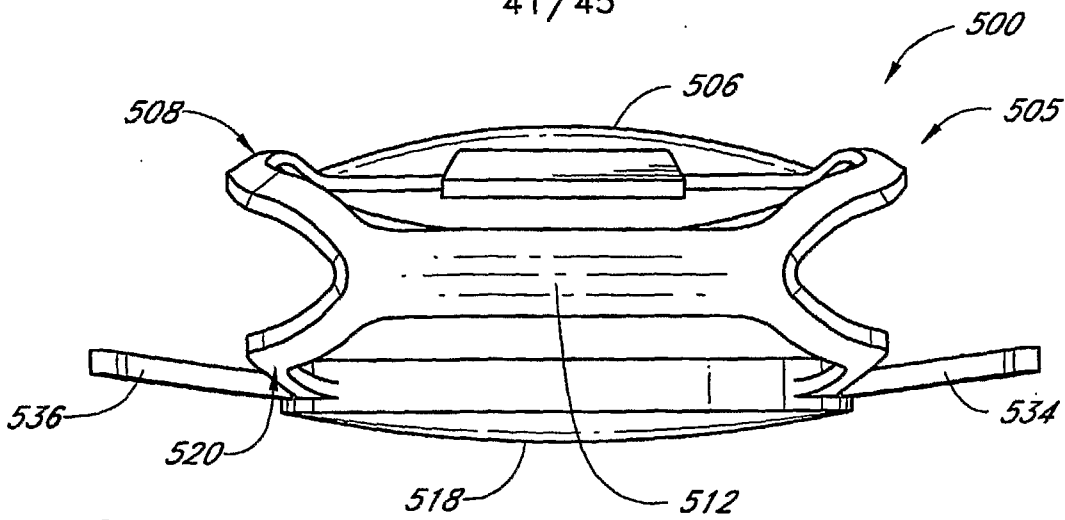

FIG. 38

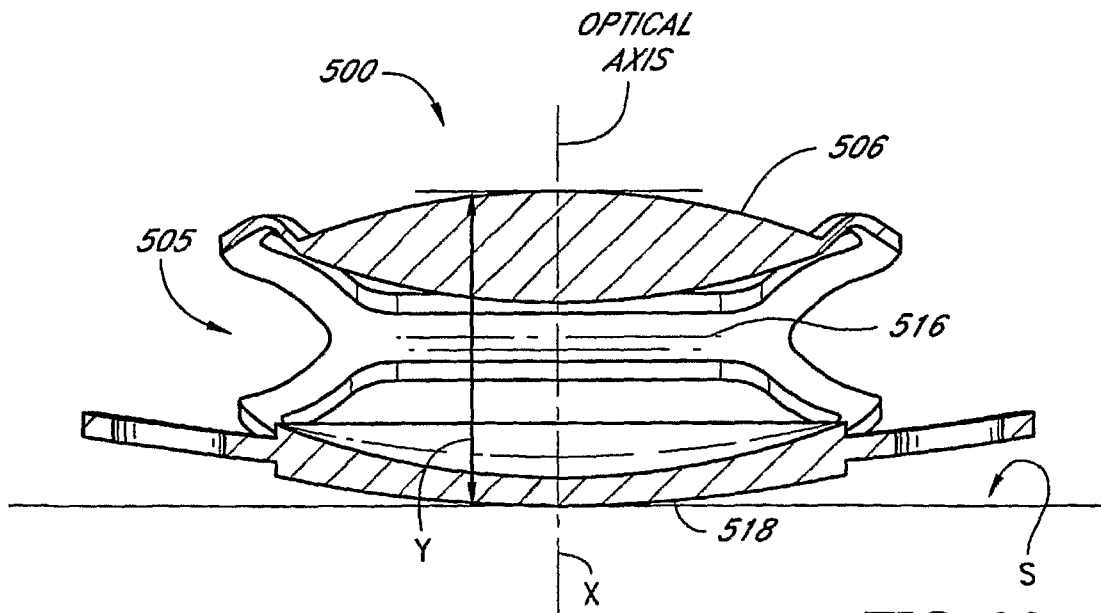

FIG. 39

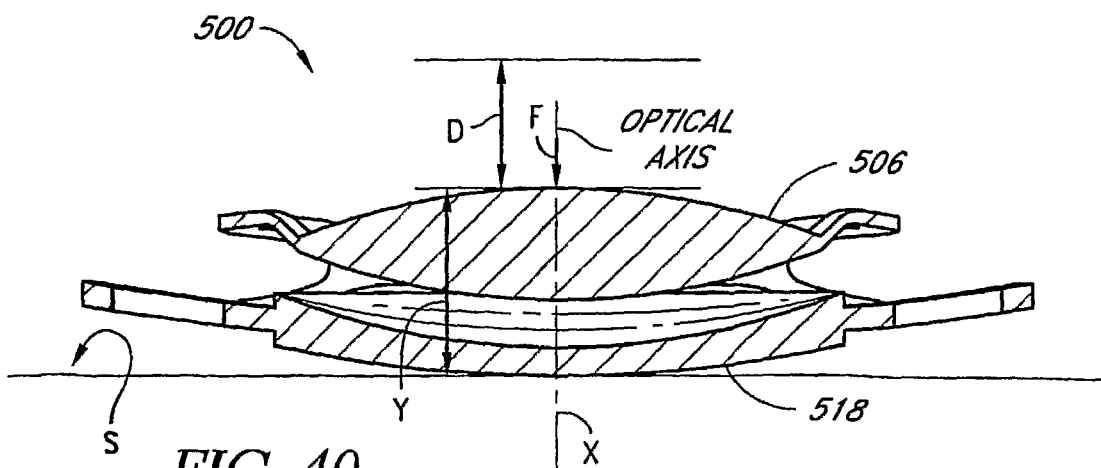

FIG. 40  
SUBSTITUTE SHEET (RULE 26)

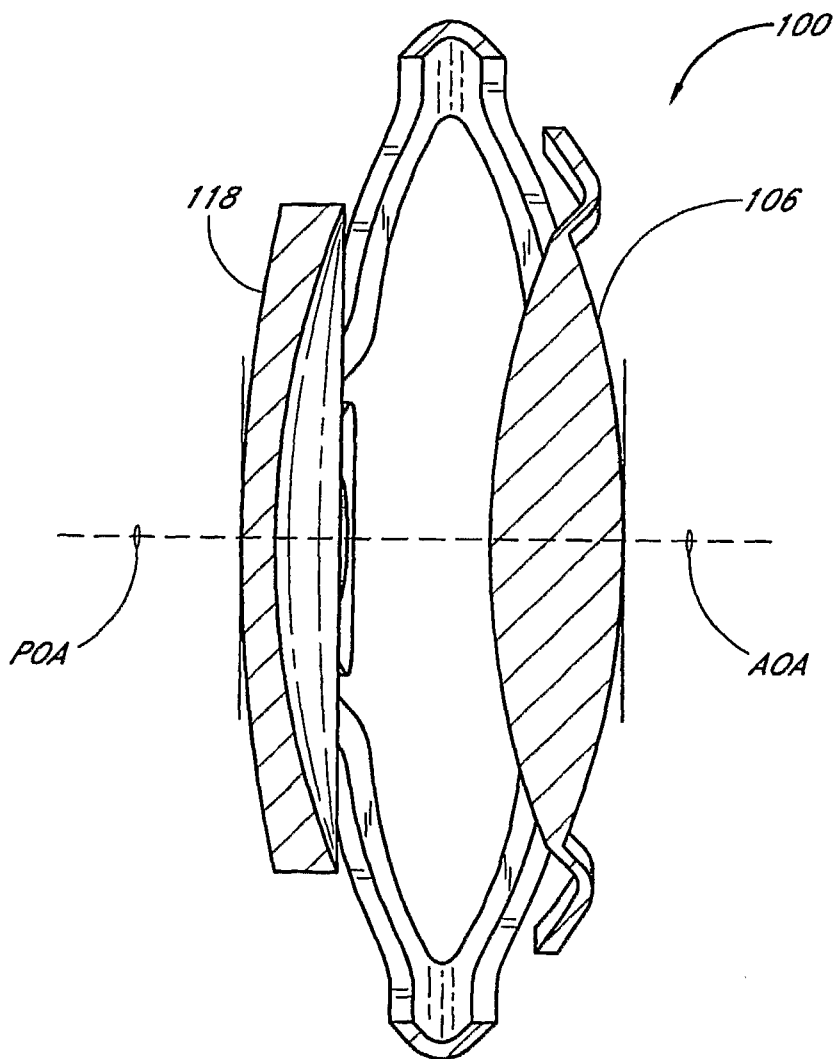

FIG. 41

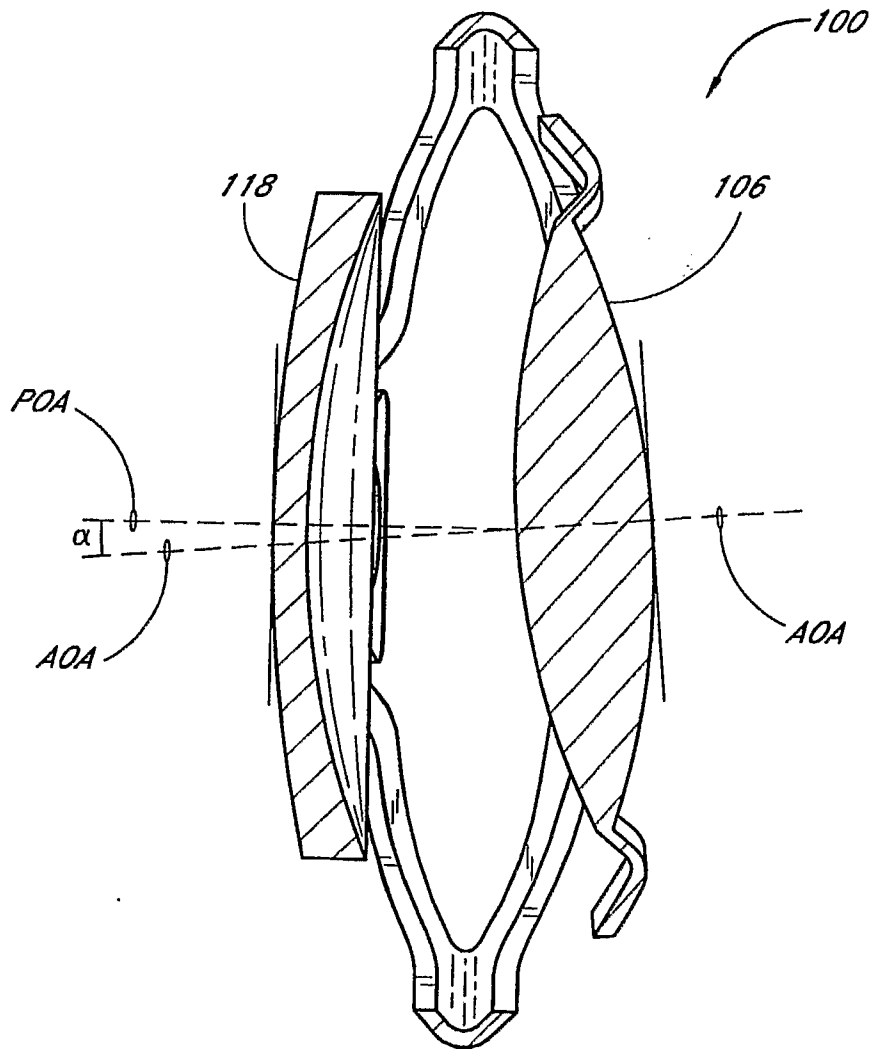

FIG. 42



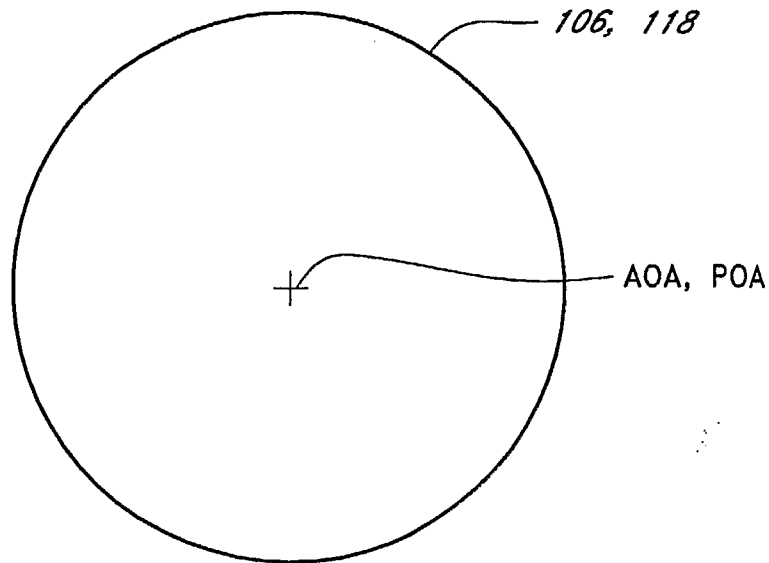

FIG. 43

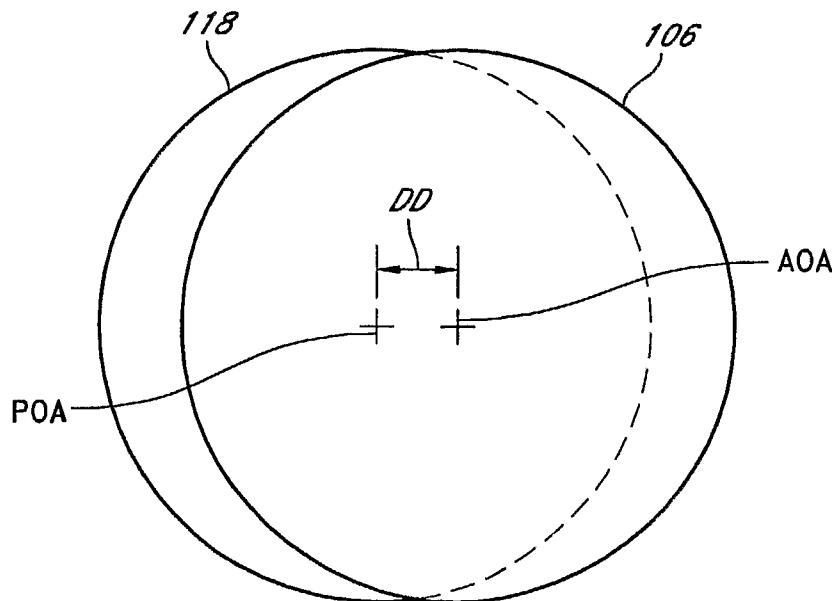
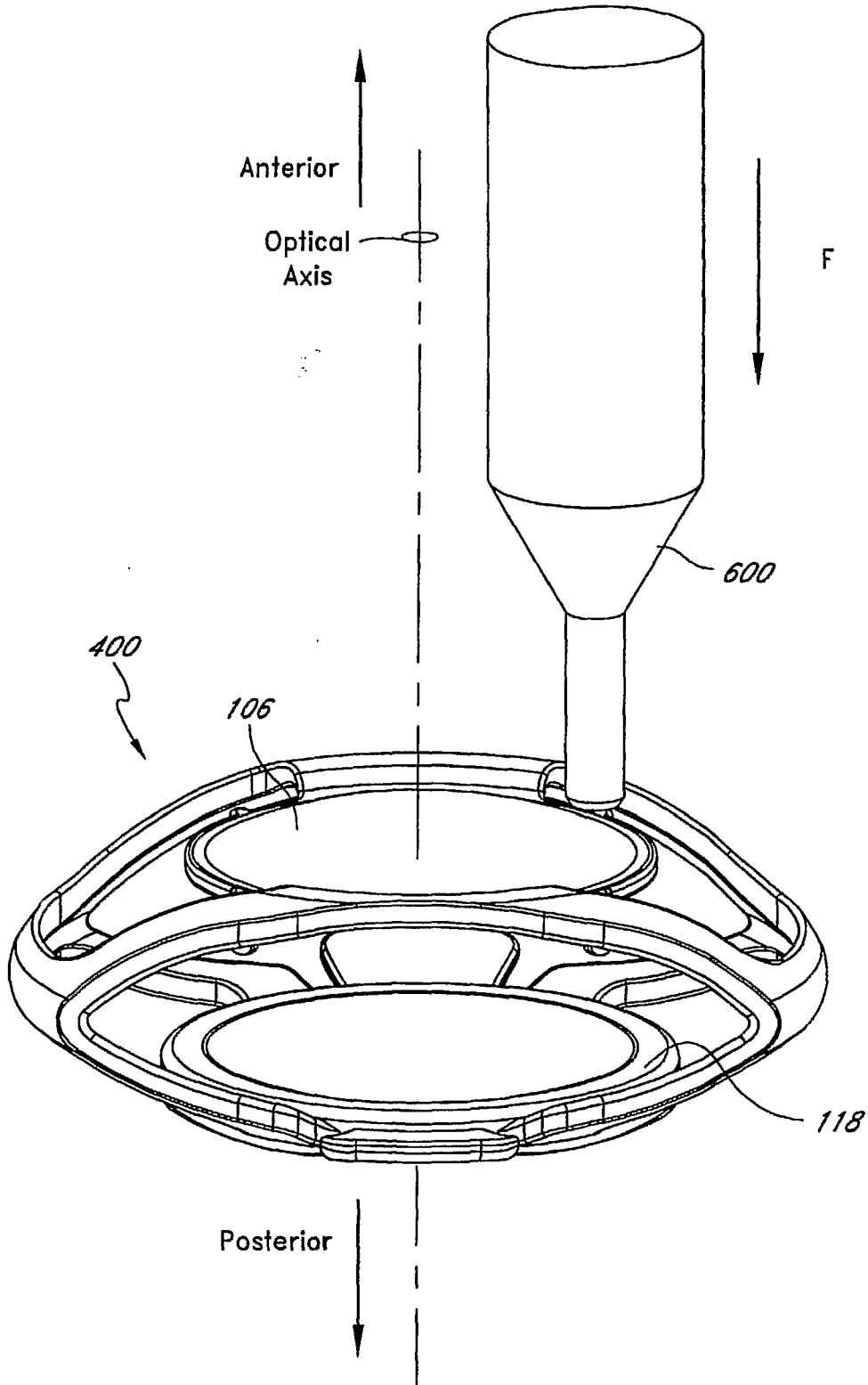

FIG. 44  
SUBSTITUTE SHEET (RULE 26)



**FIG. 45**  
**SUBSTITUTE SHEET (RULE 26)**

# INTERNATIONAL SEARCH REPORT

International application No  
PCT/US2006/029852

|   |  |                       |
|---|--|-----------------------|
| <b>A. CLASSIFICATION OF SUBJECT MATTER</b><br>INV. A61F2/16   |  |                       |
| According to International Patent Classification (IPC) or to both national classification and IPC   |  |                       |
| <b>B. FIELDS SEARCHED</b>   |  |                       |
| Minimum documentation searched (classification system followed by classification symbols)<br>A61F   |  |                       |
| Documentation searched other than minimum documentation to the extent that such documents are included in the fields searched   |  |                       |
| Electronic data base consulted during the international search (name of data base and, where practical, search terms used)<br>EPO-Internal, WPI Data  |  |                       |
| <b>C. DOCUMENTS CONSIDERED TO BE RELEVANT</b>   |  |                       |
| Category*   | Citation of document, with indication, where appropriate, of the relevant passages   | Relevant to claim No. |
| X   | US 2002/173847 A1 (PHAM HAI-MINH [US] ET AL ZADNO-AZIZI GHOLAM-REZA [US] ET AL)<br>21 November 2002 (2002-11-21)   | 9-13, 17, 22          |
| Y   | paragraphs [0091], [0093], [0105], [0108], [0109]  | 23, 24, 27, 30-32     |
| A   | figures 6, 22  | 1, 5, 6, 16           |
| Y   | -----<br>NIO Y-K ET AL: "EFFECT OF INTRAOCULAR LENS IMPLANTATION ON VISUAL ACUITY, CONTRAST SENSITIVITY, AND DEPTH OF FOCUS" JOURNAL CATARACT AND REFRACTIVE SURGERY, AMERICAN SOCIETY OF CATARACT AND REFRACTIVE, US, vol. 29, no. 11, November 2003 (2003-11), pages 2073-2081, XP009065364<br>ISSN: 0886-3350 | 23, 24, 27, 30-32     |
| A   | page 2074; table 6<br>page 2079<br>-----   | 1                     |
| -/--  |  |                       |
| <input checked="" type="checkbox"/> Further documents are listed in the continuation of Box C.  |  |                       |
| <input checked="" type="checkbox"/> See patent family annex.  |  |                       |
| * Special categories of cited documents :   |  |                       |
| *A* document defining the general state of the art which is not considered to be of particular relevance  |  |                       |
| *E* earlier document but published on or after the international filing date  |  |                       |
| *L* document which may throw doubts on priority claim(s) or which is cited to establish the publication date of another citation or other special reason (as specified)   |  |                       |
| *O* document referring to an oral disclosure, use, exhibition or other means  |  |                       |
| *P* document published prior to the international filing date but later than the priority date claimed  |  |                       |
| *T* later document published after the international filing date or priority date and not in conflict with the application but cited to understand the principle or theory underlying the invention   |  |                       |
| *X* document of particular relevance; the claimed invention cannot be considered novel or cannot be considered to involve an inventive step when the document is taken alone  |  |                       |
| *Y* document of particular relevance; the claimed invention cannot be considered to involve an inventive step when the document is combined with one or more other such documents, such combination being obvious to a person skilled in the art. |  |                       |
| *&* document member of the same patent family   |  |                       |
| Date of the actual completion of the international search   | Date of mailing of the international search report   |                       |
| 10 January 2007   | 16/01/2007   |                       |
| Name and mailing address of the ISA/<br>European Patent Office, P.B. 5818 Patentlaan 2<br>NL - 2280 HV Rijswijk<br>Tel. (+31-70) 340-2040, Tx. 31 651 epo nl,<br>Fax: (+31-70) 340-3016   | Authorized officer<br><br>Merté, Birgit  |                       |

## INTERNATIONAL SEARCH REPORT

International application No  
PCT/US2006/029852

C(Continuation). DOCUMENTS CONSIDERED TO BE RELEVANT

| Category* | Citation of document, with indication, where appropriate, of the relevant passages   | Relevant to claim No.              |
|-----------|--|------------------------------------|
| A         | WO 2004/090611 A2 (BAUSCH & LOMB [US];<br>ALTMAN GRIFFITH E [US] BAUSCH & LOMB [US];<br>ALTMANN) 21 October 2004 (2004-10-21)<br>page 9, line 26 - page 11, line 3<br>-----  | 1-4, 8,<br>18, 19,<br>22, 24-36    |
| A         | ALTMANN GRIFFITH E: "wavefront-customized<br>intraocular lens"<br>CURRENT OPINION IN OPHTHALMOLOGY,<br>vol. 15, no. 4, August 2004 (2004-08),<br>pages 358-364, XP009075917<br>United States<br>page 358 - page 361<br>----- | 1-4,<br>18-20,<br>23-30,<br>32, 36 |

# INTERNATIONAL SEARCH REPORT

International application No.  
PCT/US2006/029852

## Box II Observations where certain claims were found unsearchable (Continuation of item 2 of first sheet)

This International Search Report has not been established in respect of certain claims under Article 17(2)(a) for the following reasons:

1.  Claims Nos.:  
because they relate to subject matter not required to be searched by this Authority, namely:
  
2.  Claims Nos.:  
because they relate to parts of the International Application that do not comply with the prescribed requirements to such an extent that no meaningful international Search can be carried out, specifically:
  
3.  Claims Nos.:  
because they are dependent claims and are not drafted in accordance with the second and third sentences of Rule 6.4(a).

## Box III Observations where unity of invention is lacking (Continuation of item 3 of first sheet)

This International Searching Authority found multiple inventions in this international application, as follows:

see additional sheet

1.  As all required additional search fees were timely paid by the applicant, this International Search Report covers all searchable claims.
2.  As all searchable claims could be searched without effort justifying an additional fee, this Authority did not invite payment of any additional fee.
3.  As only some of the required additional search fees were timely paid by the applicant, this International Search Report covers only those claims for which fees were paid, specifically claims Nos.:
  
4.  No required additional search fees were timely paid by the applicant. Consequently, this International Search Report is restricted to the invention first mentioned in the claims; it is covered by claims Nos.:

Remark on Protest

The additional search fees were accompanied by the applicant's protest.

No protest accompanied the payment of additional search fees.

**FURTHER INFORMATION CONTINUED FROM PCT/ISA/ 210**

This International Searching Authority found multiple (groups of) inventions in this international application, as follows:

1. claims: 1-8 and and claims 32-36

AIOL having increased aberration due to a certain force characteristic of the biasing members  
---

2. claims: 9-22 and claims 32-36

AIOL having certain relative dimensional characteristics (in particular claim 9 + claim 14/claim 15 and claims depending therefrom)  
---

3. claims: 23-31 and claims 32-36

AIOL with optics having within their range of relative motion a first configuration in which said anterior optical axis is sufficiently misaligned relative to said posterior optical axis to introduce optical aberration in the  
---

# INTERNATIONAL SEARCH REPORT

Information on patent family members

International application No

PCT/US2006/029852

| Patent document cited in search report |    | Publication date |    | Patent family member(s) |  | Publication date |
|--|----|------------------|----|-------------------------|--|------------------|
| US 2002173847                          | A1 | 21-11-2002       | US | 2005165410 A1           |  | 28-07-2005       |
| WO 2004090611                          | A2 | 21-10-2004       | US | 2005203619 A1           |  | 15-09-2005       |