



(11) **EP 2 025 954 A1**

(12) **EUROPEAN PATENT APPLICATION**

(43) Date of publication:
18.02.2009 Bulletin 2009/08

(51) Int Cl.:
F16B 33/00 (2006.01) **B29C 65/00** (2006.01)
B29C 65/56 (2006.01)

(21) Application number: **08162257.3**

(22) Date of filing: **12.08.2008**

(84) Designated Contracting States:
AT BE BG CH CY CZ DE DK EE ES FI FR GB GR HR HU IE IS IT LI LT LU LV MC MT NL NO PL PT RO SE SI SK TR
Designated Extension States:
AL BA MK RS

(71) Applicant: **The Boeing Company**
Chicago, IL 60606-2016 (US)
(72) Inventor: **Keener, Steven G.**
Trabuco Canyon, CA 92679-1185 (US)
(74) Representative: **Pitchford, James Edward**
Kilburn & Strode
20 Red Lion Street
London WC1R 4PJ (GB)

(30) Priority: **14.08.2007 US 838573**

(54) **Method for fastening components using a composite two-piece fastening system, and the related assembled part**

(57) A method for attaching parts. A composite male fastening component (810) is placed through at least a first part (804) and a second part (802). The composite male fastener component (810) preferably has a threaded portion. A composite female fastener component (812) is positioned adjacent to and surrounding the threaded portion of the male fastener component (810). A portion of the composite female fastener component

(812) is caused to flow around and form into the threaded portion of the composite male fastener component (810). The portion of the composite female fastener component (812) that flowed around and formed into the threaded portion of the composite male fastener component (810) is re-solidified and re-consolidated such that the composite female fastener component (812) is securely attached to the composite male fastener component (810) thereby joining the mating parts.

100		SYSTEM INTEGRATOR	THIRD PARTY	OPERATOR
102	SPECIFICATION AND DESIGN	X	X	X
104	MATERIAL PROCUREMENT	X	X	
106	COMPONENT AND SUBASSEMBLY MANUFACTURING	X	X	
108	SYSTEM INTEGRATION	X		
110	CERTIFICATION AND DELIVERY	X		
112	IN SERVICE			X
114	MAINTENANCE AND SERVICE	X	X	X

FIG. 1

EP 2 025 954 A1

Description**BACKGROUND INFORMATION****1. Field:**

[0001] The present disclosure relates generally to composite components and in particular to a method and apparatus for manufacturing composite components. Still more particularly, the present invention relates to a method and apparatus for fastening composite components to each other using a composite fastening system.

2. Background:

[0002] Aircraft are being designed and manufactured with greater and greater percentages of composite materials. Some aircraft may have more than fifty percent of their primary structure made from composite materials. Composite materials are being used in aircraft to decrease the weight of the aircraft. This decreased weight improves payload capacities and fuel efficiencies. Further, composite materials also may provide improved corrosion and fatigue resistance for various components in an aircraft thereby contributing to the overall improvement of the aircraft performance.

[0003] Composite materials are tough, light-weight materials created by combining two or more dissimilar components to create a component with stronger properties than the original materials. Composite materials are also typically non-metallic materials. In these examples, a composite is a multiphase material, in which the phase distribution and geometry may have been controlled to optimize one or more properties.

[0004] One phase is typically continuous and referred to as a matrix. The matrix may be typically more compliant than other phases and may be tougher than other phases. This matrix typically supports and binds the reinforcement together and provides environmental protection for the reinforcement. The matrix may transmit the load from one piece of reinforcement to the other, usually by shear, and may carry shear stresses of the composite. Other phases may be distributed within the matrix and are often fibrous or particulates. These distributed phases are often stiffer and stronger than the matrix and may provide the composite with its high stiffness and strength properties. For example, a composite may include fibers and resins.

[0005] Fibers that may be found in composites include, for example, graphite, boron, high-tensile glass, ceramic, and aramid used in conjunction with polyester/vinyl-ester, epoxy, ceramic, and metal matrixes. The fibers and resins may be combined by curing or heating these constituents to form a cured material or product for the composite component.

[0006] In manufacturing aircraft, various two-piece metallic fastening systems have been long used for the assembly of aircraft structures and components of all

types of metallic or non-metallic materials. Typically, metallic male fastener components are installed with mating metallic female fastener components to hold the parts together. The metallic male fastener components include, for example, threaded pins or lockbolts. The metallic female mating components may take the form of threaded collars, nuts, and/or swaged collars. Use of metallic components, however, increases the weight of the aircraft. Currently, the mechanical joining of non-metallic or composite aircraft components using metallic fasteners have been the excepted industry standard.

[0007] The use of non-metallic composite materials or even a hybrid of both metallic and non-metallic composite material components in mechanical fastener assemblies for joining non-metallic composite structural components to each other have been very limited or non-existent. The reasons for these limited uses include, for example, material property limitations, such as plastic deformation. The deformation aspects or considerations may include deformability in mating collars of two-piece systems such as lockbolts or threaded pins. Lower shear strength, galvanic corrosion, and limited compressive strength are examples of other factors that have limited the use of composite materials in fastener components.

[0008] Even with the use of large co-cured composite structures in aircraft construction, the joining of composite components using mechanical systems are still desirable especially for areas in the aircraft where the need for repair and/or replacement of the structural components is foreseen or unavoidable.

[0009] As a result, manufacturers still seek to improve fastening technology to increase levels of automation, ease of assembly, and cost and weight savings as well as other factors. Therefore, it would be advantageous to have improved fastening systems using composite materials to decrease the weight while improving the performance of the aircraft.

SUMMARY

[0010] The different advantageous embodiments of the present disclosure provide a method and apparatus for attaching parts.

[0011] In one embodiment a method is provided for assembling a composite structure for an aircraft. A composite male fastener component is positioned through a pair of aircraft parts, the composite male fastener component having a shaft and a mechanical locking feature. A composite female fastener component is positioned around the shaft and adjacent to the threaded portion of the shaft while the composite male fastener component is positioned through the pair of aircraft parts, wherein the composite female fastener component comprises carbon fiber and resin and has a cylindrical shape. Heat and force is applied to the composite female fastener component to cause a portion of the composite female fastener component to melt and flow into the mechanical locking feature. The heat and force is removed such that

the portion of the composite female fastener component that melted collar re-solidifies, wherein the composite female fastener component is attached to the composite male fastener component and the pair of mating aircraft parts are mechanically joined to each other.

[0012] In another advantageous embodiment, a method is used to attaching parts. A composite male fastener component is placed through a first part and a second part, the composite male fastener component having a mechanical locking feature. A composite female fastener component is positioned adjacent to the threaded portion. A portion of the composite female fastener component is caused to flow around the mechanical locking feature of the composite male fastener component. The portion of the composite female fastener component that flowed around the threaded portion of the composite male fastener component is solidified such that the composite female fastener component is attached to the composite male fastener component.

[0013] In yet another advantageous embodiment, a composite aircraft structure comprises a first composite aircraft part, a second composite aircraft part, a composite male fastener component, and a composite female fastener component. The composite male fastener component is placed through the first composite aircraft part and the second composite aircraft part, wherein the composite male fastener has a mechanical locking feature. The composite female fastener component is attached to the composite male fastener component through processing composite female fastener component in a manner that caused a portion of the composite female fastener component to flow around the mechanical locking feature of the composite male fastener component and re-solidify around the threaded section to join the composite female fastener component to the composite male fastener component.

[0014] The features, functions, and advantages can be achieved independently in various embodiments of the present disclosure or may be combined in yet other embodiments in which further details can be seen with reference to the following description and drawings.

BRIEF DESCRIPTION OF THE DRAWINGS

[0015] The novel features believed characteristic of the invention are set forth in the appended claims. The invention itself, however, as well as a preferred mode of use, further objectives and advantages thereof, will best be understood by reference to the following detailed description of an advantageous embodiment of the present disclosure when read in conjunction with the accompanying drawings, wherein:

Figure 1 is a description of an aircraft manufacturing and service method in which an advantageous embodiment may be implemented;

Figure 2 is a description of an aircraft in which an advantageous embodiment may be implemented;

Figure 3 is a diagram illustrating a system for fastening parts in accordance with an advantageous embodiment;

Figure 4 is a diagram illustrating a fastening system in accordance with an advantageous embodiment;

Figure 5 is a cross-sectional view of a composite female fastener component in accordance with an advantageous embodiment;

Figure 6 is a cross-sectional view of a composite female fastener component in accordance with an advantageous embodiment;

Figure 7 is a cross-sectional view of a composite male fastener component in accordance with an advantageous embodiment;

Figure 8 is a cross-sectional view of a structure assembled using a fastening system in accordance with an advantageous embodiment;

Figure 9 is a flowchart of a process for attaching parts or assembling a structure in accordance with an advantageous embodiment; and

Figure 10 is a flowchart of a process for pre-treating a fastening system in accordance with an advantageous embodiment.

DETAILED DESCRIPTION

[0016] Referring more particularly to the drawings, embodiments of the disclosure may be described in the context of aircraft manufacturing and service method **100** as shown in **Figure 1** and aircraft **200** as shown in **Figure 2**. During pre-production, aircraft manufacturing and service method **100** in **Figure 1** may include specification and design **102** of aircraft **200** in **Figure 2** and material procurement **104**. During production, component and sub-assembly manufacturing **106** and system integration **108** of aircraft **200** in **Figure 2** takes place. Thereafter, aircraft **200** in **Figure 2** may go through certification and delivery **110** in order to be placed in service **112**. While in service by a customer, aircraft **200** in **Figure 2** is scheduled for routine maintenance and service **114**, which may include modification, reconfiguration, refurbishment, and other maintenance or service.

[0017] Each of the processes of aircraft manufacturing and service method **100** may be performed or carried out by a system integrator, a third party, and/or an operator as indicated by the "X" in the grid to the right of the flow diagram of **Figure 1**. In these examples, the operator may be a customer. For the purposes of this description, a system integrator may include, without limitation, any number of aircraft manufacturers and major-system sub-contractors; a third party may include, without limitation, any number of vendors, subcontractors, and suppliers; and an operator may be an airline, leasing company, military entity, service organization, and so on.

[0018] As shown in **Figure 2**, aircraft **200**, produced by aircraft manufacturing and service method **100** in **Figure 1**, may include airframe **202** with plurality of systems **204** and interior **206**. Examples of systems **204** include

one or more of propulsion system **208**, electrical system **210**, hydraulic system **212**, environmental system **214**, and airframe system **216**.

[0019] Apparatus and methods embodied herein may be employed during any one or more of the stages of production and aircraft manufacturing and service method **100** in **Figure 1**. For example, components or sub-assemblies provided in sub-assembly manufacturing **106** may be fabricated or manufactured in a manner similar to components or sub-assemblies produced while aircraft **200** is in service. Also, one or more apparatus embodiments, method embodiments, or a combination thereof may be utilized during production stages for component and sub-assembly manufacturing **106** and system integration **108** in **Figure 1**, for example, by reducing the weight of aircraft **200**. For example, the composite fastener system in the advantageous embodiments may be used in assembling structural and other composite components in aircraft **200**. The use of these composite fastening systems reduces the weight of while improving the overall operating performance of aircraft **200**. These additional weight savings may aid in increasing fuel savings and increasing payload capacity for aircraft **200**.

[0020] The different advantageous embodiments provide a method and apparatus for attaching airframe components or parts to each other. In particular, the different advantageous embodiments may be used to assemble a composite structure for a product, such as an aircraft. A composite male fastener component is passed through at least a first part and a second part. This composite male fastener component has preferably a threaded portion. A composite female fastener component is positioned adjacent to and surrounding the threaded portion of the composite male fastener component.

[0021] A portion of the composite female fastening component may be caused to flow around or form into the threaded portion of the composite male fastener component. The portion of the composite female fastener component that flowed around or formed into the threaded portion of the composite male fastener component is re-solidified or re-consolidated such that the composite female fastener component is securely attached to the composite male fastener component. The portion of the female fastener component that flowed around or formed into the threaded portion of the composite male fastener component is preferably initiated by applying heat.

[0022] Heat is applied to the composite female fastener component to cause a portion of the composite female fastener component to flow around or form into the threaded portion of the composite male fastener component. In this example, the composite female fastener component is then cooled, causing the composite female fastener component to re-solidify or re-consolidate such that the composite female fastener component is attached or secured to the composite male fastener component.

[0023] In addition to applying heat to the composite female fastener component, pressure or force is prefer-

ably applied to the composite female fastener component to cause portions of the composite female fastener component to flow around or form into the threaded portion of the composite male fastener component. This type of assembly process may be employed during any state of manufacturing, maintenance, or repair to securely attach any type of parts or components to each other. In these examples, the parts or components attached or joined together using the composite male fastener component and the composite female fastener component are composite parts. In particular, these may be parts for an aircraft structure, such as a frame, stiffener, or wing skin, etc.

[0024] Turning next to **Figure 3**, a diagram illustrating a system for fastening parts is depicted in accordance with an advantageous embodiment. In this example, fastener assembly tool **300** retrieves a composite male fastener component from composite male fastener components **302** and a composite female fastener component from composite female fastener components **304** to form fastening system **306**. Fastening system **306** is applied to mating parts **308** as part of the process of mechanically attaching or joining parts **308** to each other. In these examples, parts **308** may be two or more parts, depending on the particular implementation. Further, parts **308** may be composite parts or components used in a product, such as an aircraft.

[0025] The composite male fastener component portion of fastening system **306** is placed through parts **308**. The composite female fastener component of fastening system **306** is placed around and adjacent to the preferably threaded portion of the composite male fastener component. In the advantageous embodiments, when fastening system **306** is in place with mating parts **308**, heat **310** and force **312** are applied to the composite female fastener component by fastener assembly tool **300**. The heat and force applied by fastener assembly tool **300** causes a portion of the composite female fastener component to flow around or form into the threaded portion of the composite male fastener component. Thereafter, the assembled fastening system, fastening system **306**, is allowed to cool. This cooling results in the composite female fastener component re-consolidating or re-solidifying in a manner that the composite female fastener component is securely attached to the composite male fastener component. In this manner, parts **308** are mechanically fastened or joined to each other.

[0026] In these examples, the composite male fastener component and the composite female fastener component in fastening system **306** may take different forms. The components employ a mechanical locking feature. In these examples, a mechanical locking feature is a feature that allows a male fastener component to be joined or locked in placed with a female fastener component. A mechanical locking feature is, for example, without limitation, a threaded section or concentric grooves in a composite male fastener component. A threaded portion in a composite female fastener component is similarly an

example a mechanical locking feature. In many cases, both composite male fastener components and composite female fastener components have these features, but are not required for the different advantageous embodiments.

[0027] In these examples, the composite male fastener component may be a lockbolt, a threaded pin, or some other shaped component containing a shaft in which part of the shaft has concentric grooves or a threaded section. The composite female fastener component may take various forms including, for example, a mating collar, a swag collar, or even a threaded nut. In some cases, the composite female fastener component may not include a mechanical locking feature, while the composite male fastener component does. The reverse also may occur for other embodiments. When in the form of a threaded nut, the composite female fastener component also includes a threaded section that interacts or engages with the threaded section of the composite male fastener component. In other embodiments, the composite female fastener component may simply have a cylindrical surface, (external, internal, or both) that may be placed around a threaded portion of the composite male fastener component.

[0028] Fastener assembly tool **300**, in these examples, may take various forms. For example, fastener assembly tool **300** may be a hand tool in which fastening system **306** is put into position and placed through mating parts **308** by hand. In this type of example, fastener assembly tool **300** provides heat **310** and force **312** to cause reshaping or re-forming of composite materials within the composite female fastener component. In other examples, fastener assembly tool **300** may be an automated or robotic-type system in which the fastener assembly tool **300** contains or retrieves a supply of fastener components, such as composite male fastener components **302** and composite female fastener components **304** to form multiple fastening systems, such as fastening system **306** to attach mating parts **308** to each other.

[0029] Turning now to **Figure 4**, a diagram illustrating a fastening system is depicted in accordance with an advantageous embodiment. In this example, fastening system **400** is an example of a fastening system, such as fastening system **306** in **Figure 3**. Fastening system **400** includes composite male fastener component **402** and composite female fastener component **404**, which has a substantially cylindrical shape. Composite male fastener component **402** slides through channels in components **406** and **408**, and then into a channel within female fastener component **404**. In this example, fastening system **400** is used to join components **406** and **408** to each other.

[0030] With reference next to **Figure 5**, a cross-sectional view of a composite female fastener component is depicted in accordance with an advantageous embodiment. In this example, composite female fastener component **500** has a cylindrical shape that is viewed in a cross-section. Composite female fastener component

500 includes inner surface **502**, which forms channel **504** through which a composite male fastener component may be received. In this example, inner surface **502** is a substantially smooth surface.

[0031] Turning next to **Figure 6**, a cross-sectional view of a composite female fastener component is depicted in accordance with an advantageous embodiment. In this example, composite female fastener component **600** has inner surface **602**, which forms channel **604** through which a composite male fastener component may be received. In this example, inner surface **602** has a threaded section.

[0032] Turning now to **Figure 7**, a cross-sectional view of a composite male fastener component is depicted in accordance with an advantageous embodiment. In this example, composite male fastener component **700** has an elongate member with threaded section **702**, which may be placed into a channel in a composite female fastener component. In this example, section **704** of composite male fastener component **700** may extend through two or more composite parts that are to be joined to each other using the fastening system in the different illustrative examples.

[0033] With reference now to **Figure 8**, a cross-sectional view of a structure assembled using a fastening system is depicted in accordance with an advantageous embodiment. In this example, structure **800** is a composite structure for an aircraft that is assembled using parts **802** and **804**. These parts are attached to each other using fastening system **808**.

[0034] In these examples, fastening system **808** is comprised of composite male fastener component **810** and composite female fastener component **812**. In particular, composite male fastener component **810** is preferably a threaded pin, and composite female fastening component **812** is a swag or 'form' collar. As can be seen, composite male fastener component **810** contains threaded section **814**. In the depicted examples, the composite male fastener component may be any elongate member that has a threaded portion. Of course, the threaded portion may only encompass part or the entire elongate member. Composite male fastener component **810** has been placed through hole **806**, which is present or drilled through mating parts **802** and **804**.

[0035] Composite female fastener component **812** includes inner surface **816** which has been placed over or positioned around threaded section **814** in composite male fastener component **810**. This positioning of composite female fastener component **812** is an example of how composite female fastener component **812** may be placed or positioned adjacent to threaded section **814** in composite male fastener component **810**.

[0036] In this particular advantageous embodiment, heat and force has been applied to composite female fastener component **812** such that at least a portion of this component flows around and forms into threaded section **814**. In particular, the composite material along inner surface **816** of composite female fastener compo-

nent **812** has flowed around and formed into threaded section **814**. Of course, any process that may cause or result in composite material along inner surface **816** to re-melt and flow or form may be employed in addition to or in place of heat and/or force. For example, an electron beam or laser may be used to heat or cause inner surface **816** of composite female fastener component **812** to flow and re-form.

[0037] Composite female fastener component **812** has been allowed to cool such that composite female fastener component **812** re-consolidates or re-solidifies around and/or in threaded section **814** in such a manner that attaches or connects composite female fastener component **812** to composite male fastener component **810**. With this type of attachment, parts **802** and **804** are now mechanically attached and joined to each other.

[0038] In these examples, the materials for composite female fastener component **812** are selected such that this component may be re-heated or re-melted at a later point to cause or result in the portions of composite female fastener component **812** around threaded section **814** to flow or form in a manner to allow composite female fastener component **812** to be removed or detached from composite male fastener component **810**. In this manner, parts **802** and **804** may be taken apart from each other and disassembled. Such a removal or disassembly of fastening system **808** may be required for repair or replacement, depending on the particular structure. Of course, materials may be selected such that once cured, composite female fastener component **812** cannot be removed from composite male fastener component **810**.

[0039] In these examples, different types of resins may be used in the composite materials that form the composite male fastener component and the composite female fastener component. On one hand, thermoset polymeric resins may be used, which becomes permanently hard when heated and will not soften again upon re-heating. On the other hand, a thermoplastic polymeric resin may be used, which can be melted and re-melted multiple times when re-heated. This latter type of resin is used in the advantageous embodiments illustrated in the different figures.

[0040] Thermoplastic polymeric resins typically have shorter processing times than thermoset polymeric resins. Further, these types of composite materials may be re-heated and re-formed repeatedly if required. This type of feature allows for the fastening system to be taken apart if needed.

[0041] Examples of thermoplastic polymeric resin materials that may be used to include, for examples, without limitation, liquid-crystal polymers (LCP); fluoroplastics, including polytetrafluoroethylene (PTFE), fluorinated ethylene propylene (FEP), perfluoroalkoxy resin (PFA), and polychlorotrifluoroethylene (PCTFE), and polytetrafluoroethylene-perfluoromethylvinylether (MFATM); ketone-based resins, including polyetheretherketone (PEEKTM); polyamides (for example nylon-6/6, 30 percent glass fiber); polyethersulfones (PES); polyamideim-

ides (PAIS), polyethylenes (PE); polyester thermoplastics, including polybutylene terephthalate (PBT), polyethylene terephthalate (PET), and poly(phenylene terephthalates); polysulfones (PSU); poly(phenylene sulfides) (PPS).

[0042] A thermoset polymeric resin is a resin that does not readily re-melt or reflow after the initial cure. Still, this type of composite resin material also may be used, depending on the particular implementation. Examples of thermoset polymeric resin materials include, for example, without limitation, allyl polymers, alkyd polyesters, bismaleimides (BMI), epoxies, phenolic resins, polyesters, polyurethanes (PUR), and polyurea-formaldehydes.

[0043] Of course, any type of material may be used depending on the various properties and the desired uses. An example of one type of thermoplastic polymeric resin, used in the illustrative examples, is aromatic polyetheretherketone. This type of material is also referred to as a PEEKTM polymer. PEEKTM is a trademark of Victrex, Plc. This type of composite material is desirable for use in the different composite fastening systems illustrated in these examples because this type of material provides extremely good chemical resistance, abrasion resistance, high temperature resistance, hydraulics resistance, flame resistance with low smoke and toxic gasses, along with excellent electrical properties and excellent resistance to gamma rays.

[0044] Further, in these examples, the composite materials employ short-fiber reinforced composites. A short-fiber is considered a composite with around twenty percent to around twenty-five percent volume fiber content. The use of this type of fiber reduces problems of fiber orientation and breakage that may occur with longer fiber composites. Of course, long-fiber reinforced composites also may be used depending on the type of fibers. A long-fiber is considered, in these examples, a composite that uses around fifty percent to around sixty percent content of glass, aramid, or carbon fibers. Other examples of materials that may be used in the composite fastening system, in these examples, are glass, carbon, or titanate fibers, which may be compounded or mixed into the thermoset polymer. These types of fibers may be used at levels of around up to thirty percent. Use of these types of fibers may improve stress cracking, cut through resistance, dimensional stability, creep, warpage, heat deflection, tensile strength, and flex modulus.

[0045] An additional feature that may be implemented in the composite fastening system, in these examples, is to 'pre-treat' or 'pre-coat' the composite fastener components. The composite male fastener component and the composite female fastener component may be 'pre-treated' or 'pre-coated' with an organic coating that improves the compatibility of these components with other dissimilar composite and metallic materials. With this improved compatibility, the assembled structures with the pre-coated composite components typically exhibit reduced issues relating to composite delamination, water

intrusion, electrical continuity of the component, arcing between components, galvanic corrosion, fuel tightness, and surface lubricity allowing relative movement due to differential expansion of the components in the structure.

[0046] With reference now to **Figure 9**, a flowchart of a process for attaching or joining parts or assembling a structure is depicted in accordance with an advantageous embodiment. In this example, the process illustrated in **Figure 9** may be implemented using fastener assembly tool **300** in **Figure 3**.

[0047] The process begins by aligning the parts (operation **900**). In these examples, the parts may be aligned by placing the parts in the proper positions with respect to each other for mechanical attachment. Then the channel or hole may be drilled or formed through the parts to allow for a composite male fastener component to be passed or inserted through the channel or hole. Depending on the particular implementation, these parts may have the holes or channel pre-drilled or pre-formed with the holes or channels being aligned with each other. Next, a composite male fastener component is placed through the aligned and adjacent parts (operation **902**). Operation **902** is performed by passing the composite male fastener component through the hole or channel that passes through the aligned and adjacent parts.

[0048] Next, a composite female fastener component is positioned adjacent to and over a threaded portion of the composite male fastener component (operation **904**). The composite female fastener component is placed or positioned adjacent to or over the threaded section of the composite male fastener component by positioning the composite female fastener component in a manner such that an inner surface or portion of the composite female fastener component is adjacent to the threaded section (s).

[0049] Thereafter, heat and force are applied to the composite female fastener component (operation **906**). In the examples, the fastener assembly tool may be heated to approximately 600°F to 700°F at a minimum, with around 100 pounds to 300 pounds of force being applied for at least around 15 to 30 seconds. These parameters are present for purposes of illustrating one embodiment. The temperature, force, and time used may vary depending on the fastening system being used in other embodiments. Depending on the particular implementation, only heat may be applied to the composite female fastener component. Operation **906** is intended to cause a portion of the composite female fastener component to flow around or form into the threaded portions of the composite male fastener component. Although heat and force are illustrated as the techniques used to cause the portion of the composite female fastener component to flow around or form into the threaded portion(s), other mechanisms may be used. For example, an electron beam or laser process may be used to cause the portion of the composite female fastener component to flow or form.

[0050] Next, the composite female fastener component is cooled (operation **908**) with the process terminat-

ing thereafter. This cooling of the composite female fastener component may occur by removing the heat source that was applying heat to this component. In other examples, the composite fastener component may actually be cooled with a cooling system. Operations **906** and **908** are performed as part of a curing step or process for the composite fastening system that causes the composite female fastener component to be attached or joined to the composite male fastener component.

[0051] Turning now to **Figure 10**, a flowchart of a process for pre-treating components of a fastening system is depicted in accordance with an advantageous embodiment. The process illustrated in **Figure 10** may be applied to components of a composite fastening system prior to the use of the fastening system to mechanically attach or join parts to each other.

[0052] The process begins by cleaning the fastener components (operation **900**). In this operation, the cleaning may be performed to remove oils or other contaminants from the surface of the composite components. By removing oils and other contaminants, mechanical bonding of the coating to the fastener may be increased. The process applies coating solution **1001** to the fastener components (operation **1002**). The coating solution is a coating material in a solution. In operation **1002**, a coating material is provided, preferably in solution, so that it may be readily and evenly applied to the components. The usual function of the coating material is to protect the base material, to which it is applied from corrosion activity, including, for example, conventional electrolytic corrosion, galvanic corrosion, and stress corrosion. In these examples, the coating material is a formulation that is primarily of an organic composition, but which may contain additives to improve the properties of the final coating. In one embodiment, the coating is initially dissolved in a carrier liquid so that it can be applied to a substrate.

[0053] Any suitable coating approach, such as dipping, spraying, brushing, or a fluidized bed method can be used. In the preferred approach, the solution of coating material dissolved in solvent is sprayed onto the component precursor.

[0054] A typical sprayable coating solution preferably has about 30 percent by weight ethanol, about 7 percent by weight toluene, about 45 percent by weight methyl ethyl ketone (MEK) as the solvent; and about 2 percent by weight strontium chromate, about 2 percent by weight aluminum powder, with the balance being mixed with phenolic resin and at least one plasticizer. A small amount of polytetrafluoroethylene may optionally be added. Such a product is available commercially under the name, Hi-Kote 1™ from Lisi Aerospace-Hi-Shear Corp., Torrance, California. This product has a standard elevated temperature curing treatment of one hour at +425 degrees, +/- 25 degrees, as recommended by the manufacturer. The Hi-Kote 1™ coating and other similar coatings are described in commonly assigned U.S. Patent Numbers 5,614,037, 5,858,133, 5,922,472, and 5,944,918, the contents of which are incorporated herein

by reference to the extent they do not conflict with the explicit text of this specification.

[0055] The coating material is preferably provided in solution so as to be evenly applied. The coating material preferably is a formulation that is primarily of an organic nature but may also contain additives to improve the properties of the final coating. By way of example, a Teflon™ compound may be added to improve coating lubricity, which allows for reduced insertion force requirements, better hole fill, and improved sheet take-up. By way of another example, aluminum powder pigment may be added to improve overall coating material integrity. The coating is desirably dissolved initially in a carrier liquid to facilitate various methods of deposition on a substrate.

[0056] According to one embodiment, the outer surface of the composite fastener component is soap cleaned and dried (i.e., degreased) prior to application of the coating. Degreasing cleans the composite surface of oils or other contaminants that may be present upon the outer surface of the fastener component. Degreasing increases the mechanical bonding of the coating to surface of the fastener component. The coatings in the advantageous embodiments are internally coherent and are uniformly deposited at a preferred thickness range from around 0.0003 inch to around 0.0005 inch, though the coating may have other thicknesses if desired.

[0057] Thereafter, the fastener components with the applied coating are thermally-treated to cure the coating (operation **1004**), with the process terminating thereafter and with the components becoming ready for use.

[0058] The curing operation is employed to effect structural changes within the organic component, typically cross-linking of the organic molecules to improve the adhesion and cohesion of the coating.

[0059] Optionally, before curing in operation **1004**, the majority of solvent in the coating solution may be removed from the as-applied coating by drying or "flash cure" **1003**, either at room temperature or slightly elevated temperature, so that the coated article or component is dry to the touch. Flash cure or drying may be achieved at about 200 degrees for about one to two minutes and accomplishes evaporation of the majority of solvent, allowing the coated article or component to be handled without altering or damaging the coating layer.

[0060] The coated component may still not be suitable for service after drying or flash cure because the coating may not have sufficiently cured and adhered to the surface of the composite component and because the coating itself is not sufficiently coherent or cross-linked to resist corrosion activity or mechanical damage during installation or subsequent service.

[0061] A number of curable, organic coating materials are available and operable in the present process. More specifically, the coating material may be any of a wide variety of curable organic coating materials having aromatic resins, such as phenolics, polyamides, and polybenoxazoles. The resin or resins are preferably mixed

with one or more plasticizers, other organic components such as polytetrafluoroethylene, and inorganic additives such as aluminum powder and/or strontium chromate or other corrosion-inhibiting additives. These coating compounds are preferably dissolved in a suitable solvent present in an amount to produce a desired application consistency. For polyaromatic resins, generally the solvent is advantageously a mixture of ethanol, toluene, and methyl ethyl ketone (MEK).

[0062] To fully cure the coating, in these examples, the coating is heated to and maintained above the curing temperature of the coating material as described in operation **1004**. With this recommended "full-up" or full-curing process, cure time will vary with the coating material used and the associated cure temperature selected. Typical cure temperatures range from about +250 degrees to about +450°F, and typical cure times range from about one hour to about four hours, not respective, and more typically from about +400 degrees to about +450 degrees for about 1 to about 1.5 hours, not respective. It is understood that the term "pre-coated" or "pre-coating" refers to the coating process of the fastener component prior to installation and assembly in its final use.

[0063] In the case of the Hi-Kote 1™ coating, a flash cure temperature of +200 degrees for one to two minutes or full cure temperature of +425 degrees for approximately one hour are exemplary. The majority of the solvent portion of the coating is removed by a "flash-cure" drying process at a slightly elevated temperature of +200 degrees for one to two minutes. Flash curing volatilizes the volatile portion of the coating solvent and allows handling of the coated fastener prior to full curing.

[0064] The coatings of the present invention are internally coherent and are uniformly deposited at a preferred thickness range from about 0.0003 inch to about 0.0005 inch, though the coating may have other thicknesses if desired. Surprisingly, it has been demonstrated through testing that the coating deposited onto a rivet-type fastener, and subsequently cured, is able to withstand the installation forces placed upon the pre-coated rivet during upset. For example, the pre-coated fastener components of one embodiment of the present invention meet required ultimate double shear strength requirements useful in aircraft primary structural applications. Specifically, the fasteners of this embodiment must meet the ultimate shear strength requirements for uncoated rivets of a minimum of 34,500 lbs./in² while exhibiting no perceptible impact on the coating integrity even if the protruding shanks of the rivets are expanded during installation to a diameter of about 1.6 times their initial diameters.

[0065] Actual test results from double shear tests surprisingly indicated that the pre-coated composite rivets did in fact conform to the requirements established by the uncoated composite rivets. Specifically, the ultimate shear strength values ranged from 34,900 lbs./in² to 40,400 lbs./in² with an average of 37,400 lbs./in². No evidence of spalling or other unsatisfactory conditions regarding the coating adherence was evident upon inspec-

tion of the rivet upsets after installations.

[0066] The description of the different advantageous embodiments has been presented for purposes of illustration and description and is not intended to be exhaustive or limited to the invention in the form disclosed. Many modifications and variations will be apparent to those of ordinary skill in the art. Further, different advantageous embodiments may provide different advantages as compared to other advantageous embodiments. The embodiment or embodiments selected are chosen and described in order to best explain the principles of the invention, the practical application, and to enable others of ordinary skill in the art to understand the invention for various embodiments with various modifications as are suited to the particular use contemplated.

Claims

1. A method for assembling a composite structure for an aircraft, the method comprising:

positioning a composite male fastener component through a pair of aircraft parts, the composite male fastener component having a shaft and a mechanical locking feature;

positioning a composite female fastener component around the shaft and adjacent to the threaded portion of the shaft while the composite male fastener component is positioned through the pair of aircraft parts, wherein the composite female fastener component comprises carbon fiber and resin and has a cylindrical shape;

applying heat and force to the composite female fastener component to cause a portion of the composite female fastener component to melt and flow into the mechanical locking feature; and removing the heat and force such that the portion of the composite female fastener component that melted collar re-solidifies, wherein the composite female fastener component is attached to the composite male fastener component and the pair of mating aircraft parts are mechanically joined to each other.

2. The method of claim 1, wherein the composite female fastener component has an externally cylindrical shape and a threaded section on an inside portion of the composite female fastener component designed to mechanically interact and engage with the threaded portion of the composite male fastener component.

3. The method of claim 1, wherein the resin is selected from one of a thermoplastic polymeric resin or a thermoset polymeric resin.

4. The method of claim 1 further comprising:

applying a coating of a material to the composite male and female fastener components; and thermally-treating the composite male and female fastener components to cure the coating prior to positioning the composite male fastener component through the pair of aircraft parts.

5. The method of claim 1, wherein the first part and the second part are composite parts.

6. The method of claim 5, wherein the composite parts are aircraft parts.

7. The method of claim 1, wherein the mechanical locking feature is one of a threaded or concentric grooves.

8. A method for attaching parts, the method comprising:

placing a composite male fastener component through a first part and a second part, the composite male fastener component having a mechanical locking feature;

positioning a composite female fastener component adjacent to the threaded portion;

causing a portion of the composite female fastener component to flow around the mechanical locking feature of the composite male fastener component; and

solidifying the portion of the composite female fastener component that flowed around the threaded portion of the composite male fastener component such that the composite female fastener component is attached to the composite male fastener component.

9. The method of claim 8, wherein the causing step comprises:

applying heat to the composite female fastener component to cause the portion of the composite female fastener component to flow around the threaded portion of the composite male fastener component.

10. The method of claim 8, wherein the solidifying step comprises:

cooling the composite female fastener component to cause the composite female fastener component to solidify such that the composite female fastener component is attached to the composite male fastener component.

11. The method of claim 10, wherein the cooling step comprises:

ceasing application of heat to the composite fe-

- male fastener component.
- 12.** The method of claim 9, wherein the causing step further comprises:
- applying pressure to the composite female fastener component while applying the heat to the composite female fastener composite component.
- 13.** The method of claim 8, wherein the composite female fastening component has a threaded section on an inside portion of the composite female fastener component designed to mechanically interact with the threaded portion of the composite male fastener component.
- 14.** The method of claim 8, wherein the composite female fastener component includes a resin that is selected from one of a thermoplastic polymeric resin or a thermoset polymeric resin.
- 15.** The method of claim 8, wherein the first part and the second part are composite parts.
- 16.** The method of claim 15, wherein the composite components are aircraft parts.
- 17.** The method of claim 15, wherein the composite parts are vehicle parts.
- 18.** The method of claim 8, wherein the mechanical locking feature is one threads or concentric grooves.
- 19.** A composite aircraft structure comprising:
- a first composite aircraft part;
a second composite aircraft part;
a composite male fastener component placed through the first composite aircraft part and the second composite aircraft part, wherein the composite male fastener has a mechanical locking feature; and
a composite female fastener component attached to the composite male fastener component through processing composite female fastener component in a manner that caused a portion of the composite female fastener component to flow around the mechanical locking feature of the composite male fastener component and re-solidify around the threaded section to join the composite female fastener component to the composite male fastener component.
- 20.** The composite aircraft structure of claim 19, wherein the first composite aircraft part and the second composite aircraft part are part of a wing for an aircraft.
- 21.** The composite aircraft structure of claim 19, wherein the first composite aircraft part and the second composite aircraft part are structural components in an aircraft.

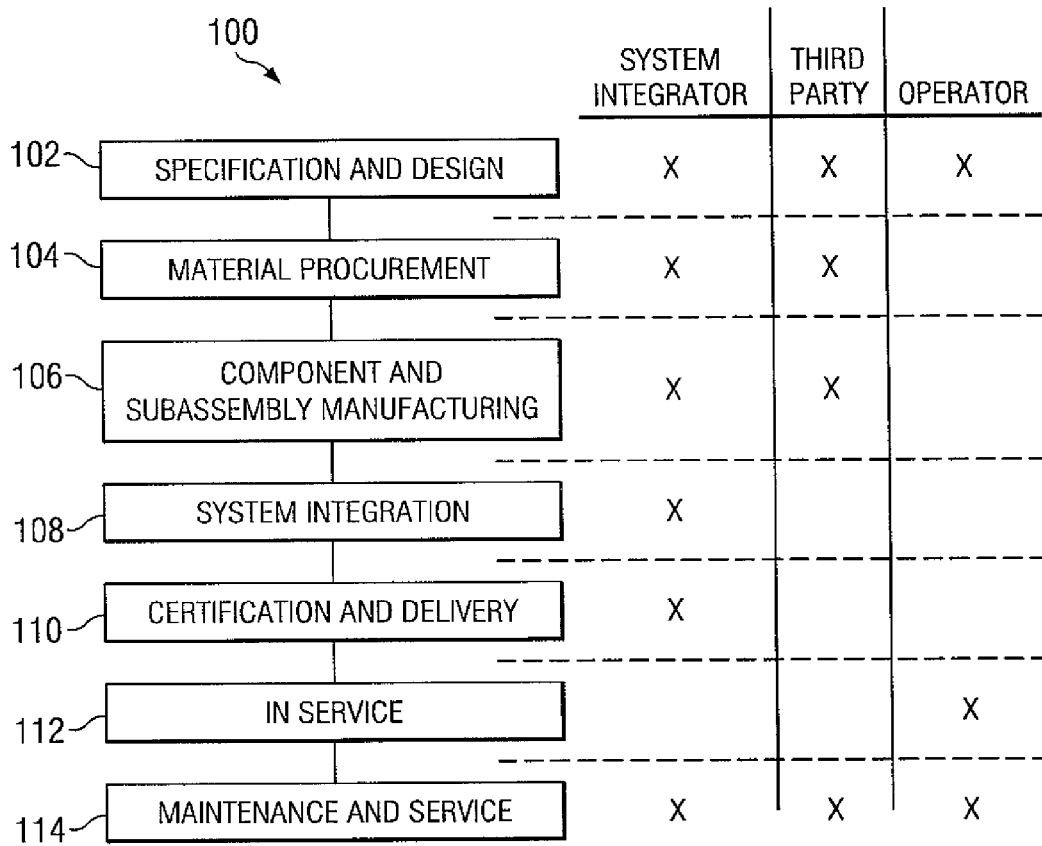

FIG. 1

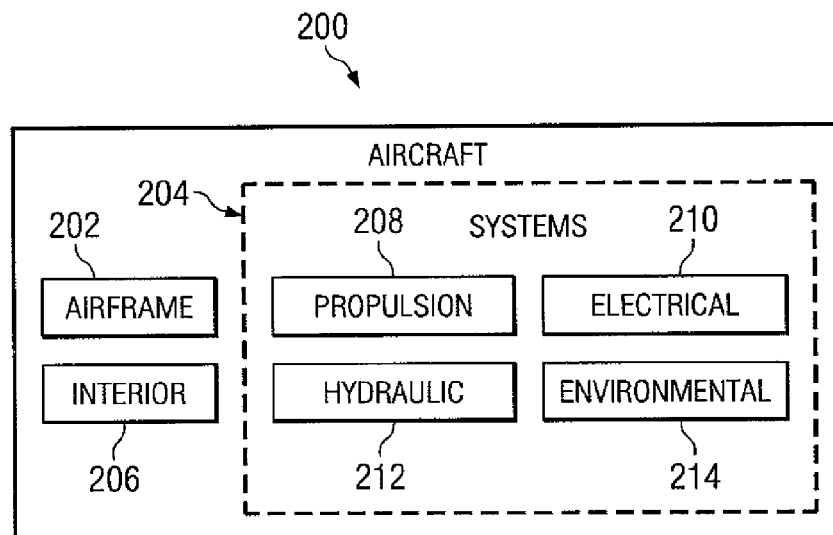

FIG. 2

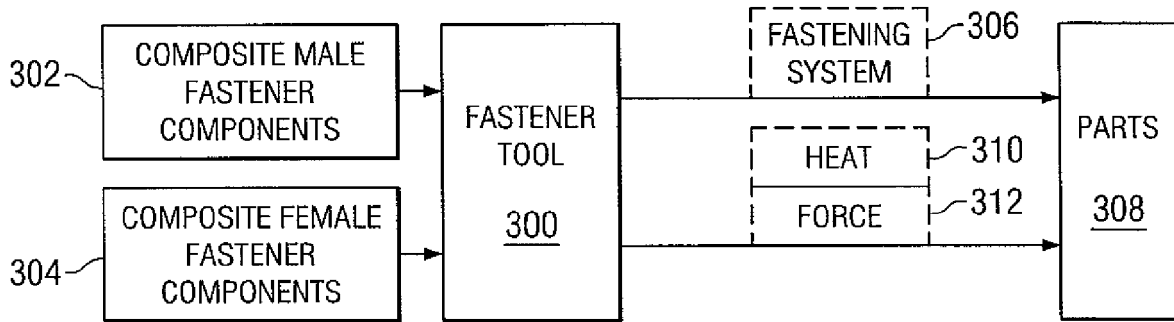

FIG. 3

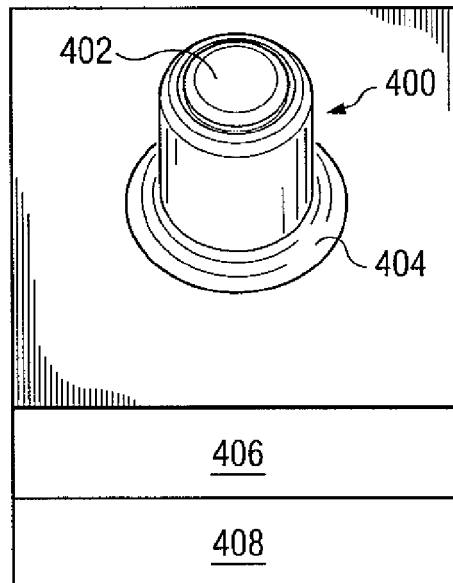

FIG. 4

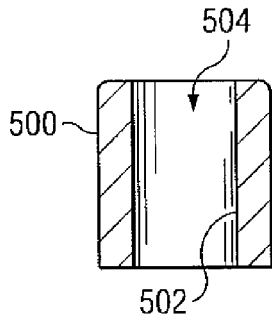

FIG. 5

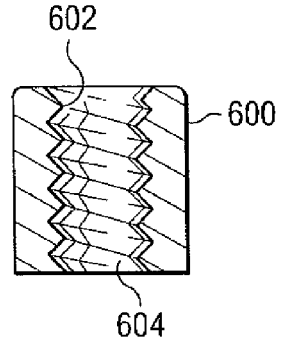

FIG. 6

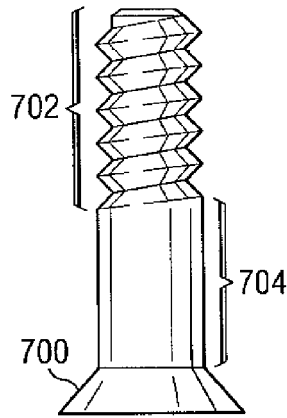

FIG. 7

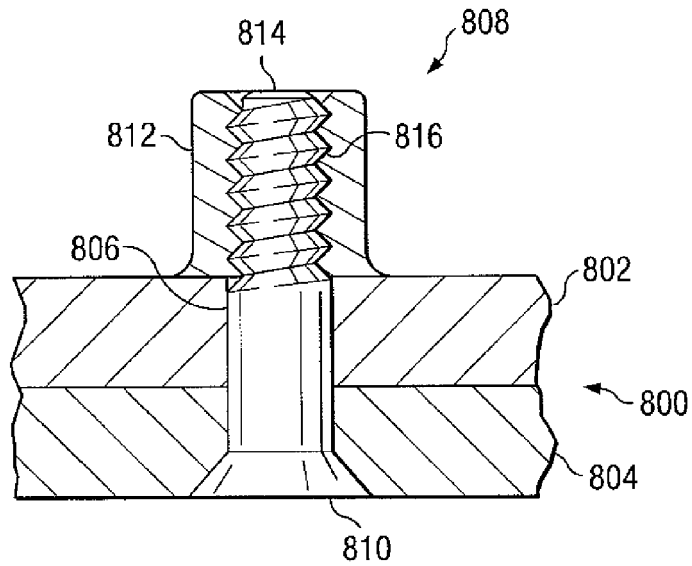

FIG. 8

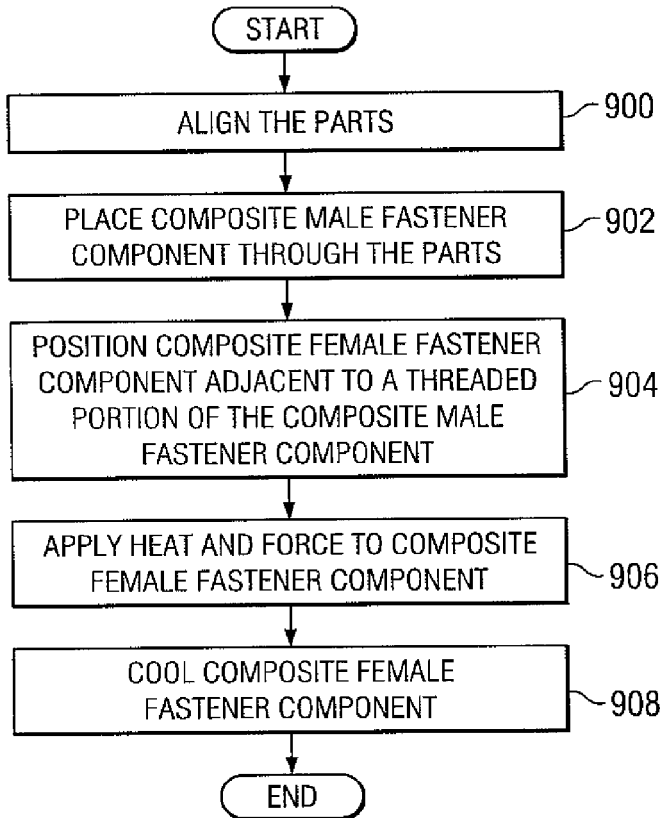

FIG. 9

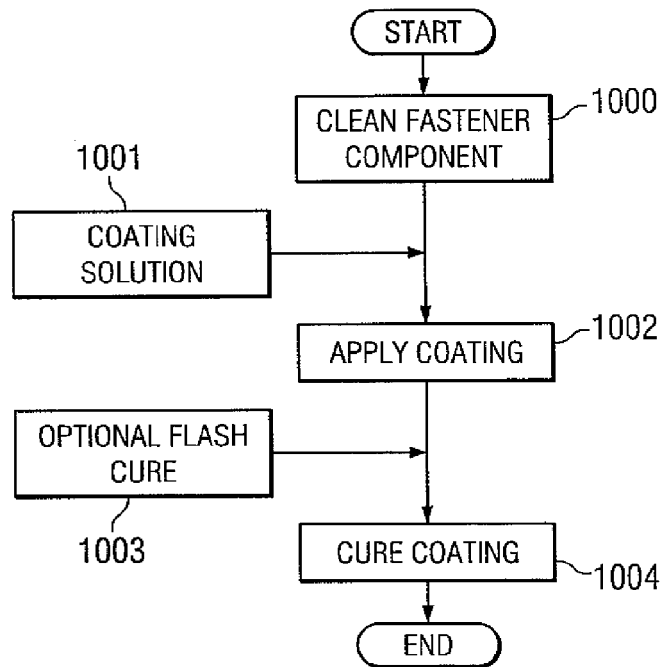

FIG. 10



EUROPEAN SEARCH REPORT

Application Number
EP 08 16 2257

DOCUMENTS CONSIDERED TO BE RELEVANT			
Category	Citation of document with indication, where appropriate, of relevant passages	Relevant to claim	CLASSIFICATION OF THE APPLICATION (IPC)
X	EP 0 203 748 A (MICRODOT INC [US]) 3 December 1986 (1986-12-03)	1-3,5-21	INV. F16B33/00 B29C65/00 B29C65/56
Y	* column 1, line 8 - line 30 * * column 2, line 4 - line 35 * * figures 1-6 *	4	
X	US 4 687 394 A (BERECZ IMRE [US]) 18 August 1987 (1987-08-18)	1-3,5-21	
Y	* figures 1,2 * * column 1, line 10 - column 2, line 3 *	4	
Y	WO 2005/092517 A (BOEING CO [US]; KEENER STEVEN G [US]) 6 October 2005 (2005-10-06) * page 2, line 16 - line 18 * * figure 1 *	4	
A	US 2006/243860 A1 (KISMARTON MAX U [US]) 2 November 2006 (2006-11-02) * figure 5 * * claims 16,22 *	1-21	
			TECHNICAL FIELDS SEARCHED (IPC)
			F16B B64C B29C
The present search report has been drawn up for all claims			
Place of search Munich		Date of completion of the search 26 November 2008	Examiner Jouannon, Fabien
CATEGORY OF CITED DOCUMENTS X : particularly relevant if taken alone Y : particularly relevant if combined with another document of the same category A : technological background O : non-written disclosure P : intermediate document		T : theory or principle underlying the invention E : earlier patent document, but published on, or after the filing date D : document cited in the application L : document cited for other reasons & : member of the same patent family, corresponding document	

4
EPO FORM 1503 03.82 (P04C01)

**ANNEX TO THE EUROPEAN SEARCH REPORT
ON EUROPEAN PATENT APPLICATION NO.**

EP 08 16 2257

This annex lists the patent family members relating to the patent documents cited in the above-mentioned European search report. The members are as contained in the European Patent Office EDP file on
The European Patent Office is in no way liable for these particulars which are merely given for the purpose of information.

26-11-2008

Patent document cited in search report		Publication date	Patent family member(s)	Publication date
EP 0203748	A	03-12-1986	CA 1275362 C	23-10-1990
			DE 3660603 D1	29-09-1988
			ES 8705584 A1	16-07-1987
			JP 61278612 A	09-12-1986
			US 4687395 A	18-08-1987

US 4687394	A	18-08-1987	NONE	

WO 2005092517	A	06-10-2005	EP 1735111 A1	27-12-2006

US 2006243860	A1	02-11-2006	CA 2601827 A1	09-11-2006
			EP 1893479 A2	05-03-2008
			WO 2006118691 A2	09-11-2006

REFERENCES CITED IN THE DESCRIPTION

This list of references cited by the applicant is for the reader's convenience only. It does not form part of the European patent document. Even though great care has been taken in compiling the references, errors or omissions cannot be excluded and the EPO disclaims all liability in this regard.

Patent documents cited in the description

- US 5614037 A [0054]
- US 5858133 A [0054]
- US 5922472 A [0054]
- US 5944918 A [0054]