



US00D976801S

(12) **United States Design Patent**
Hickey et al.

(10) **Patent No.:** **US D976,801 S**

(45) **Date of Patent:** **** Jan. 31, 2023**

(54) **TRUCK CAP**

OTHER PUBLICATIONS

(71) Applicant: **Truck Accessories Group, LLC**,
Elkhart, IN (US)

US 8,480,157 B2, 07/2013, Igura (withdrawn)
(Continued)

(72) Inventors: **Jeffrey Joal Hickey**, Sturgis, MI (US);
Donald Richard Ireland, Middlebury,
IN (US); **Terrill D. Becker**, Bristol, IN
(US); **Mitchell Austin Westra**, Granger,
IN (US); **James Dillard Fletcher**,
Elkhart, IN (US)

Primary Examiner — Cary M Robinson
Assistant Examiner — Adam C Mager
(74) *Attorney, Agent, or Firm* — Barnes & Thornburg
LLP

(73) Assignee: **TRUCK ACCESSORIES GROUP,
LLC**, Elkhart, IN (US)

(57) **CLAIM**

(**) Term: **15 Years**

The ornamental design of a truck cap, as shown and
described.

(21) Appl. No.: **29/711,962**

(22) Filed: **Nov. 4, 2019**

(51) **LOC (14) Cl.** **12-16**

(52) **U.S. Cl.**
USPC **D12/404**

(58) **Field of Classification Search**
USPC D12/222, 400, 401, 402, 403, 404, 405,
D12/412, 414
CPC ... B60J 11/00; B60J 11/02; B60J 11/04; B60J
11/06; B60J 11/08; B60J 7/00; B60J
7/1607; B60J 7/1621
See application file for complete search history.

DESCRIPTION

FIG. 1 is a perspective view of a new truck cap design;
FIG. 2 is another perspective view of the new truck cap
design of FIG. 1;
FIG. 3 is a side view of the new truck cap design of FIG. 1;
FIG. 4 is another side view of the new truck cap design of
FIG. 1;
FIG. 5 is another side view of the new truck cap design of
FIG. 1 with the cap door open;
FIG. 6 is a perspective view of the new truck cap design of
FIG. 1 with the cap door open;
FIG. 7 is another perspective view of the new truck cap
design of FIG. 1 with the cap door open;
FIG. 8 is a rear view of the new truck cap design of FIG. 1
with the cap door open;
FIG. 9 is a rear view of the new truck cap design of FIG. 1;
and,
FIG. 10 is a front view of the new truck cap design of FIG.
1.

Any broken lines shown in these drawings are for purposes
of illustrating portions of the design of the truck cap and
form no part of the claimed design.

(56) **References Cited**

U.S. PATENT DOCUMENTS

2,925,303 A * 2/1960 Lane B60J 7/104
296/102
D211,017 S * 5/1968 Willison D12/404
D232,822 S * 9/1974 Knoss et al. D12/404
(Continued)

FOREIGN PATENT DOCUMENTS

AU 2016247199 A1 5/2017
CA 133317 S 7/2010
(Continued)

1 Claim, 9 Drawing Sheets

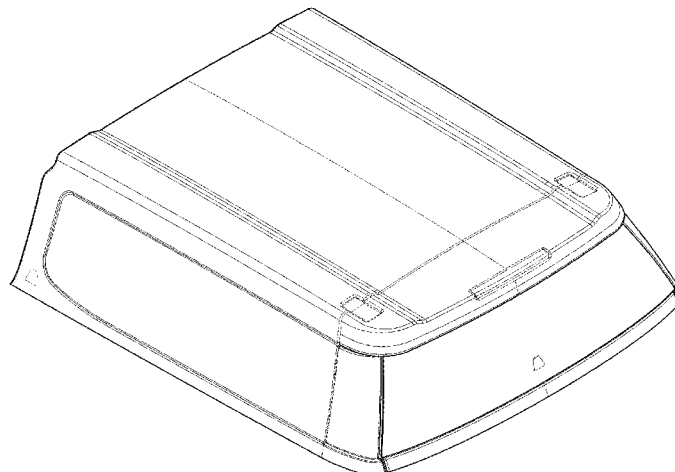

(56)

References Cited

U.S. PATENT DOCUMENTS

4,063,762 A * 12/1977 Williams B60P 3/341
 296/167
 D254,905 S * 5/1980 Collins D12/404
 D281,488 S * 11/1985 Collins D12/404
 D290,945 S * 7/1987 Geisler D12/404
 D293,094 S * 12/1987 Brown D12/404
 D299,223 S * 1/1989 Galvin D12/404
 D311,165 S * 10/1990 Moore D12/403
 5,072,984 A 12/1991 Jackson
 D324,015 S * 2/1992 Quiniones D12/404
 D325,551 S * 4/1992 Quiniones D12/404
 D326,441 S * 5/1992 Rogers D12/404
 D328,062 S * 7/1992 Burgess D12/404
 D329,837 S * 9/1992 Rogers D12/404
 D332,934 S * 2/1993 Brown D12/181
 5,314,225 A * 5/1994 Gordon B60J 7/106
 296/10
 D379,173 S * 5/1997 Quiniones D12/404
 D383,432 S * 9/1997 Starr D12/404
 D387,029 S * 12/1997 Heinemann D12/404
 D388,049 S * 12/1997 Reardon D12/403
 D403,652 S * 1/1999 Starr D12/404
 D431,225 S * 9/2000 Perlman D12/404
 D444,445 S * 7/2001 Schroeder D12/404
 6,343,828 B1 2/2002 Young et al.
 6,557,918 B2 5/2003 Lafrate et al.
 6,561,560 B2 5/2003 Brown et al.
 6,764,125 B2 7/2004 Bacon
 7,021,698 B2 4/2006 Yamada et al.
 7,226,108 B2 6/2007 Altman
 D551,124 S 9/2007 Aneiros et al.
 D597,445 S 8/2009 Hong
 D610,067 S 2/2010 Frankham
 7,673,928 B2 3/2010 Walker et al.
 D619,077 S 7/2010 Frankham
 D619,078 S 7/2010 Frankham
 D623,583 S * 9/2010 Girardi D12/404
 8,523,269 B2 7/2013 Igura
 8,511,742 B2 8/2013 Legler et al.
 8,622,458 B2 1/2014 Hache
 8,708,397 B2 4/2014 Daylong
 9,079,548 B1 7/2015 Singer
 9,272,484 B2 3/2016 Roberts, Jr.
 9,393,855 B2 7/2016 Rohr et al.
 D765,013 S 8/2016 Hindelang et al.
 9,566,915 B1 2/2017 Singer
 9,573,530 B1 2/2017 Singer
 9,751,469 B1 9/2017 Singer
 9,827,916 B1 11/2017 Singer
 9,956,857 B1 5/2018 Singer
 9,975,501 B1 5/2018 Frederick et al.
 10,005,501 B2 6/2018 Povinelli et al.
 10,046,631 B2 8/2018 Porter et al.
 D828,223 S 9/2018 Piscitelli
 10,086,684 B1 10/2018 Stamm, Jr.
 10,118,473 B2 11/2018 McDonald, II et al.
 D836,027 S 12/2018 Bollinger
 D836,487 S 12/2018 Bollinger
 D840,270 S 2/2019 Goodrich et al.
 D840,271 S 2/2019 Goodrich et al.
 10,252,679 B2 4/2019 Singer
 10,272,754 B2 4/2019 Johnson
 10,343,616 B2 7/2019 Singer
 D857,609 S 8/2019 Rohr
 D860,864 S 9/2019 Goodrich et al.
 D860,865 S 9/2019 Goodrich et al.
 D860,866 S 9/2019 Goodrich et al.
 10,406,898 B2 9/2019 O'Reilly
 D864,086 S 10/2019 Breece
 11,279,213 B2 * 3/2022 Hickey B60R 11/0235
 2003/0038505 A1 * 2/2003 Sisson B60J 7/198
 296/164
 2003/0071483 A1 * 4/2003 Sutton B60J 1/16
 296/146.16
 2008/0203756 A1 8/2008 Lake

2010/0327618 A1 * 12/2010 Soldatelli B60J 7/1621
 296/100.1
 2018/0237082 A1 8/2018 Povinelli et al.
 2019/0061499 A1 2/2019 McDonald, II et al.
 2019/0225135 A1 7/2019 Dorn
 2019/0283684 A1 9/2019 Singer
 2020/0031211 A1 1/2020 Singer
 2020/0130485 A1 * 4/2020 Ireland E05B 79/10
 2020/0398644 A1 * 12/2020 Voss B60H 1/262
 2022/0203811 A1 * 6/2022 Hickey B60P 7/02

FOREIGN PATENT DOCUMENTS

CA 133318 S 7/2010
 CA 2939281 A1 9/2015
 CA 176967 S 7/2018
 CA 3039128 A1 10/2018
 CA 180047 S 4/2019
 CA 186635 S 4/2019
 CN 1309614 C 4/2007
 CN 3668298 S 7/2007
 CN 301646869 S 8/2011
 CN 301860153 S 3/2012
 CN 301994903 S 7/2012
 CN 102119089 B 7/2013
 CN 102245414 B 11/2013
 CN 302650048 S 11/2013
 CN 302992620 S 11/2014
 CN 102089147 B 12/2014
 CN 303168343 S 4/2015
 CN 303238798 S 6/2015
 CN 303376859 S 9/2015
 CN 303376860 S 9/2015
 CN 303415050 S 10/2015
 CN 303507416 S 12/2015
 CN 303531200 S 12/2015
 CN 303622696 S 3/2016
 CN 303654670 S 4/2016
 CN 303669591 S 5/2016
 CN 303772750 S 8/2016
 CN 303902887 S 11/2016
 CN 303911708 S 11/2016
 CN 304043590 S 2/2017
 CN 304103340 S 4/2017
 CN 304129372 S 5/2017
 CN 304334211 S 10/2017
 CN 304577699 S 4/2018
 CN 304731379 S 7/2018
 CN 304829226 S 9/2018
 CN 304829227 S 9/2018
 CN 109109776 A 1/2019
 CN 304980280 S 1/2019
 CN 109458035 A 3/2019
 CN 305053137 S 3/2019
 CN 305080747 S 3/2019
 CN 208885102 U 5/2019
 CN 305223434 S 6/2019
 CN 305290854 S 8/2019
 CN 305407540 S 10/2019
 CN 106103163 B 11/2019
 CN 209637346 U 11/2019
 DE 102018109334 A1 10/2018
 DE 102019002597 A1 11/2019
 EM 001739848-0001 8/2010
 EM 001739848-0002 8/2010
 EM 001739848-0003 8/2010
 EM 001739848-0004 8/2010
 EM 003760453-0003 3/2017
 EM 005866522-0001 1/2019
 EM 005866522-0004 1/2019
 EP 2300250 B1 11/2011
 EP 2903843 A1 8/2015
 EP 3119624 A1 1/2017
 EP 2307197 B1 1/2018
 EP 3452331 A1 3/2019
 ES 2663705 T3 4/2018
 FR 2932418 B1 10/2013
 GB 4002492 9/2007
 GB 4032788 12/2013

(56)

References Cited

FOREIGN PATENT DOCUMENTS

GR	1008153 B	3/2014
JP	3904213 B2	1/2007
JP	3904214 B2	1/2007
JP	D1298196	4/2007
JP	D1416890	6/2011
JP	5178066 B2	4/2013
JP	5427190 B2	11/2013
JP	5427190 B2	12/2013
JP	5432996 B2	3/2014
JP	D1613470	9/2018
JP	D1613471	9/2018
JP	D1613556	9/2018
JP	D1613557	9/2018
JP	2019206317 A	12/2019
KR	300861883.0000	7/2016
KR	300973531.0000	9/2018
KR	300983519.0000	12/2018
KR	300983520.0000	12/2018

PL	2307197 T3	6/2018
RU	00060103	9/2006
RU	00067159	7/2008
RU	00079345	8/2011
RU	00110575	8/2018
WO	2015143267 A1	9/2015
WO	DM094372-002	6/2017
WO	2018193024 A1	10/2018
WO	2019213314 A1	11/2019

OTHER PUBLICATIONS

Leer 200XQ Sport, Published date unavailable [online], [retrieved on May 3, 2021]. Retrieved from the Internet: <https://www.drinkwaterts.com/leer-200xq-sport-cab-high-fiberglass-truck-cap-EcJi%7C02i.html> (Year: 2021).*

International Search Report; PCT/US20/58645; Filing Date Nov. 3, 2020; Dated May 2, 2021.

* cited by examiner

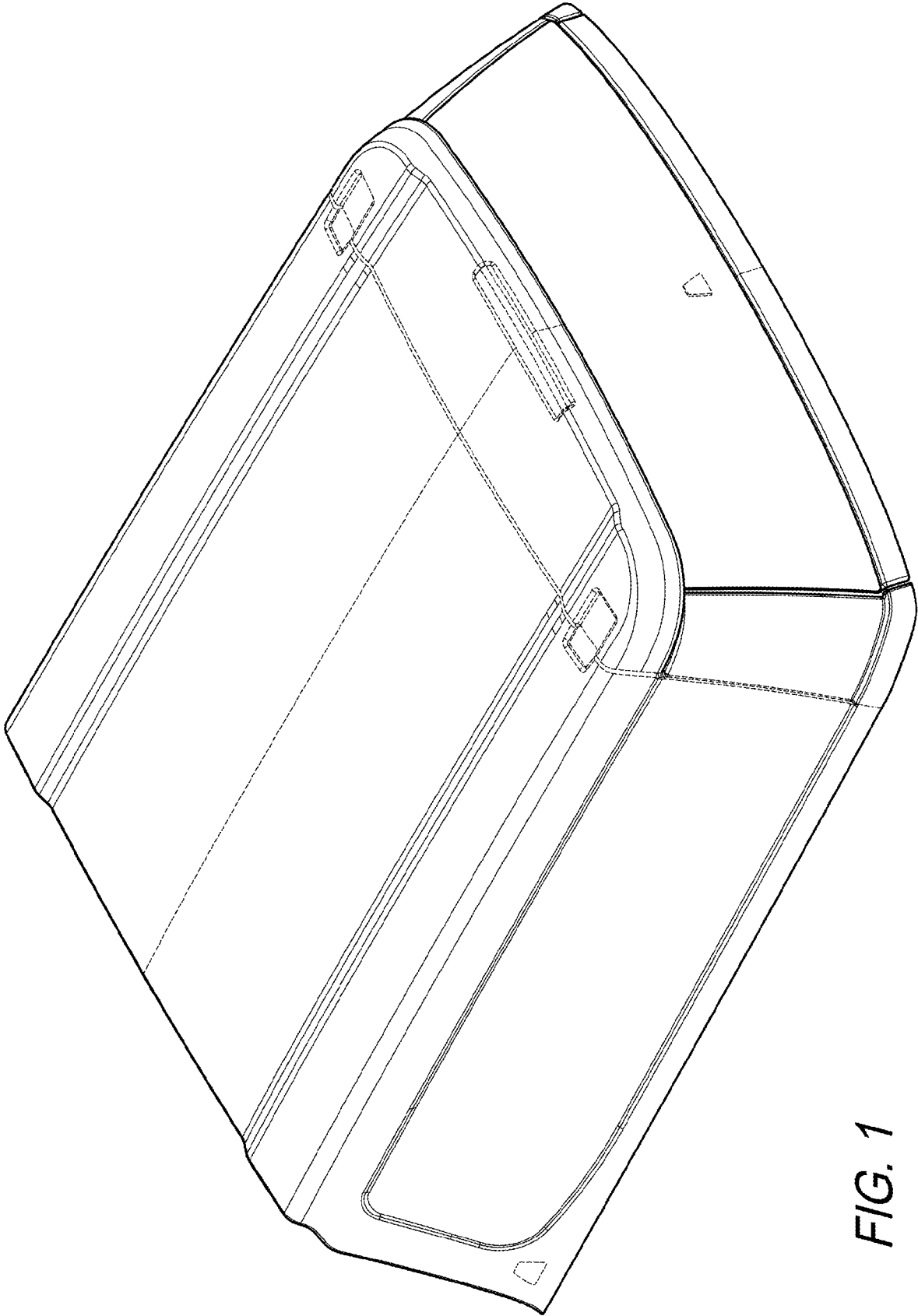

FIG. 1

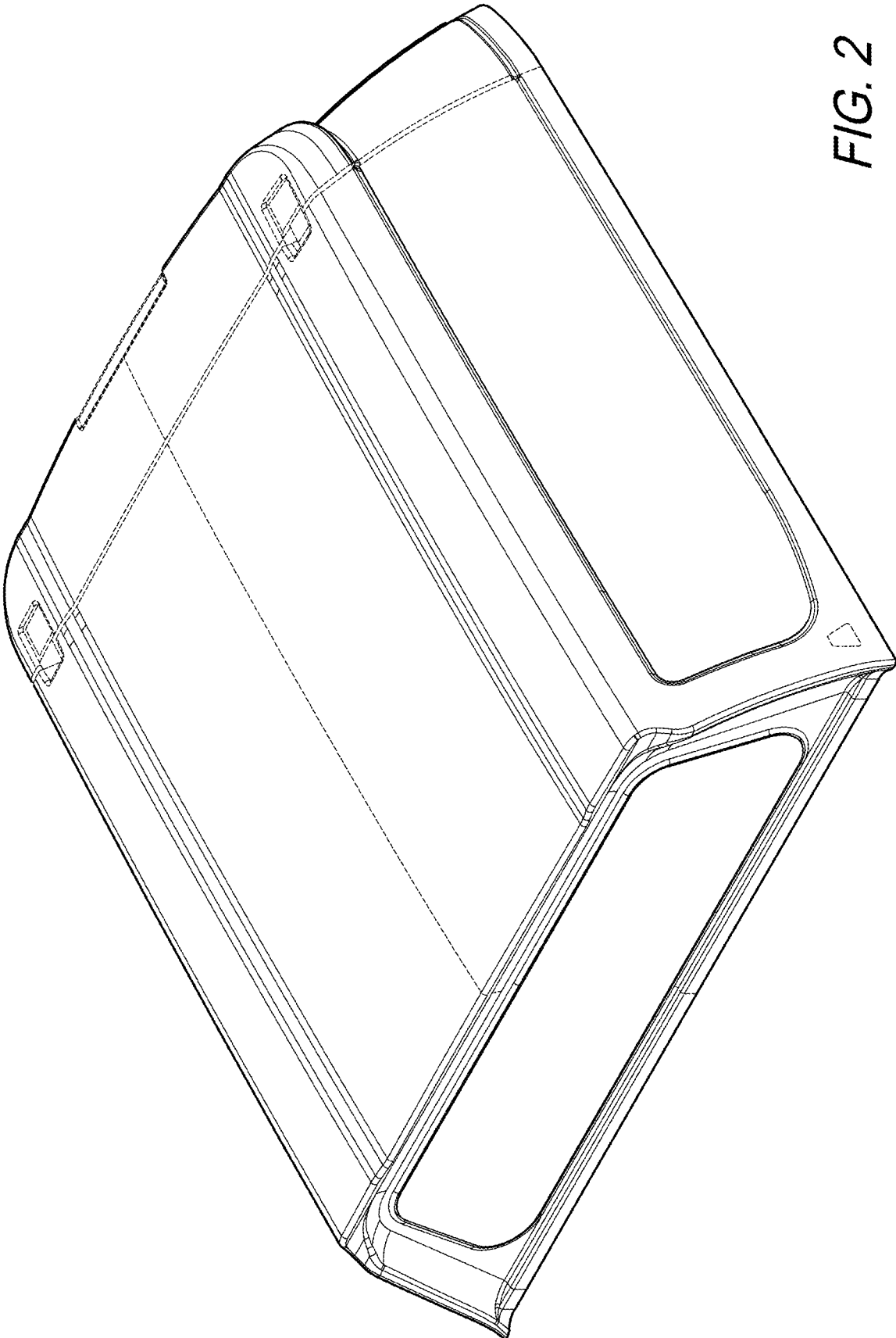

FIG. 2

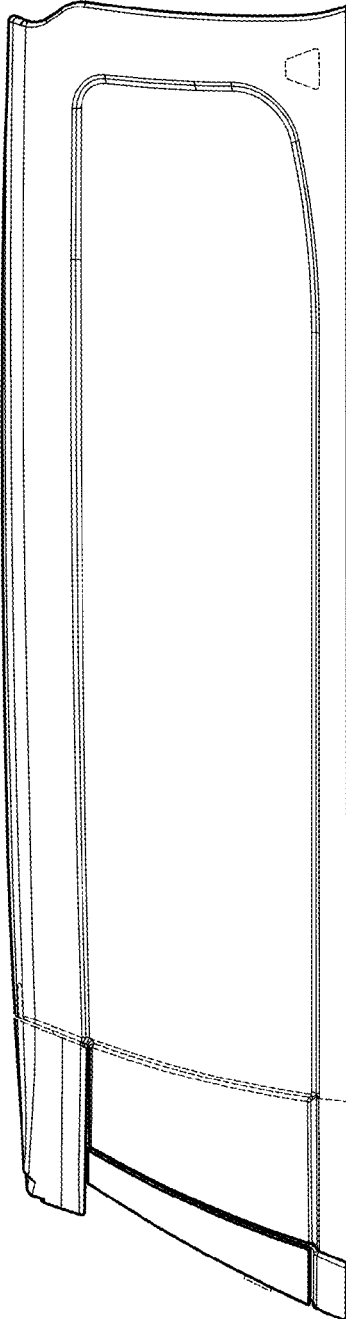

FIG. 3

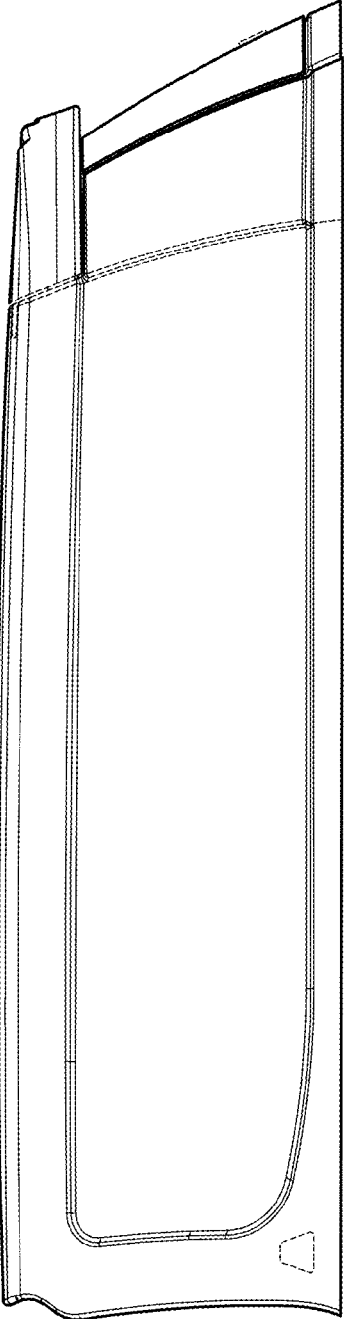

FIG. 4

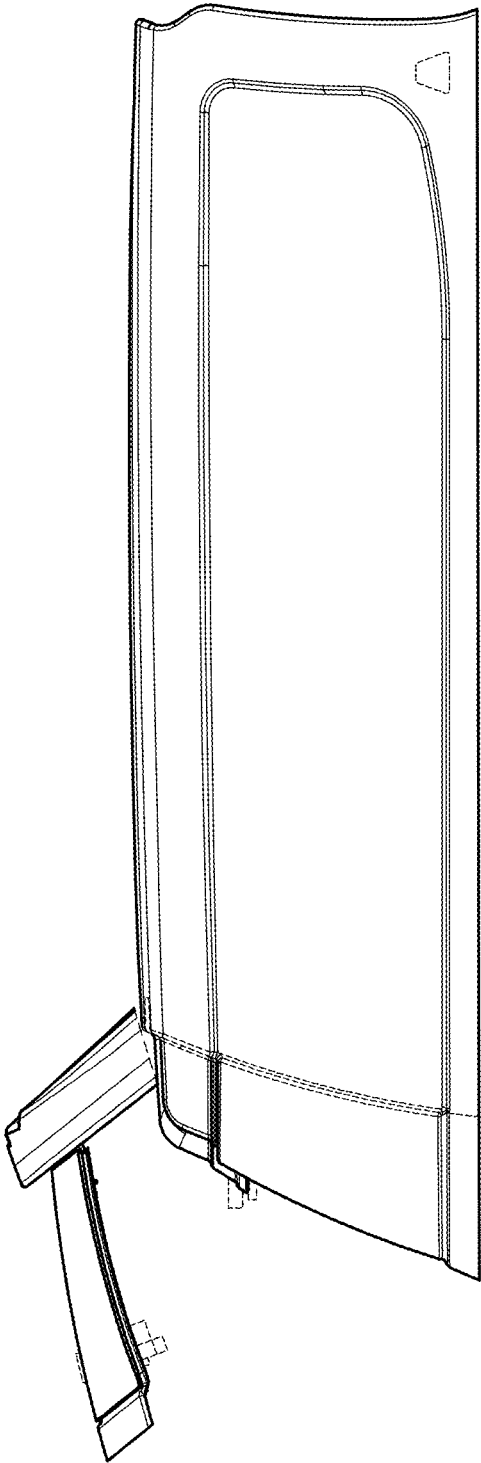

FIG. 5

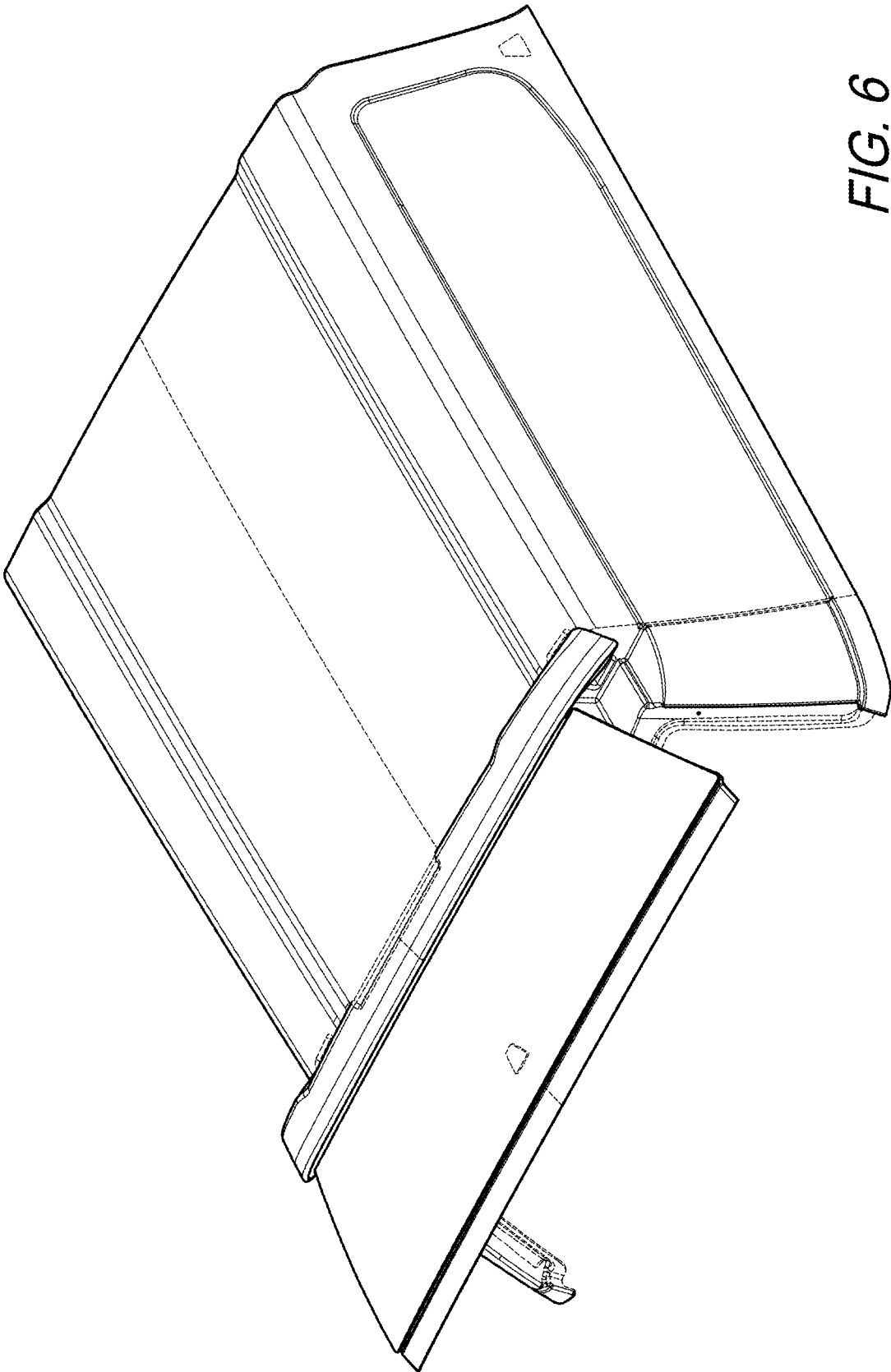

FIG. 6

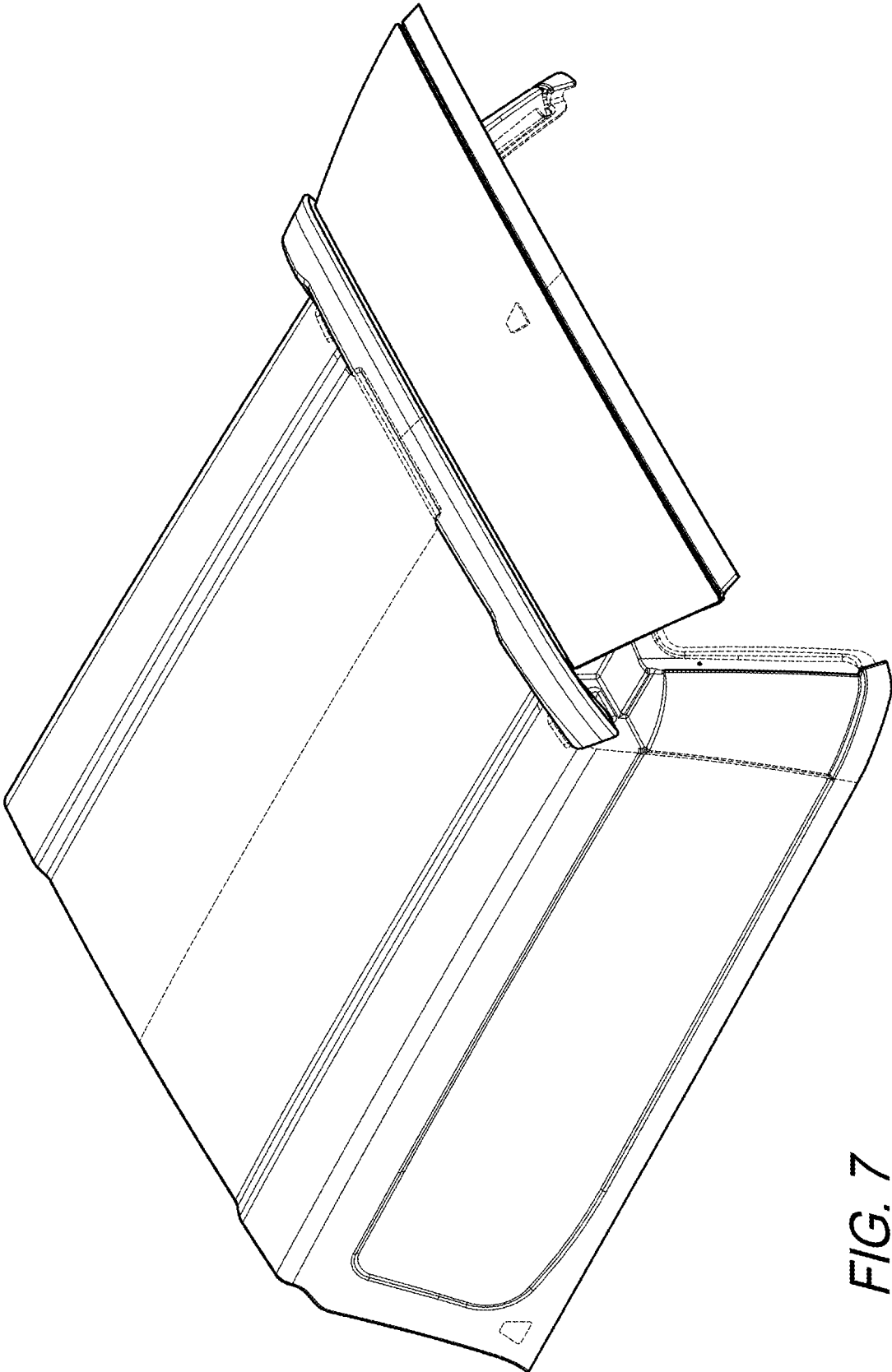

FIG. 7

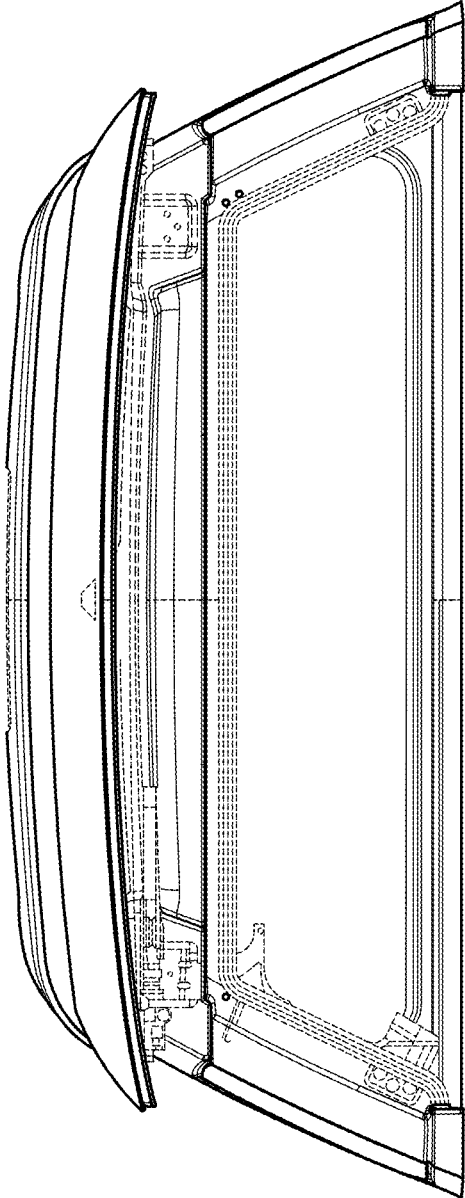

FIG. 8

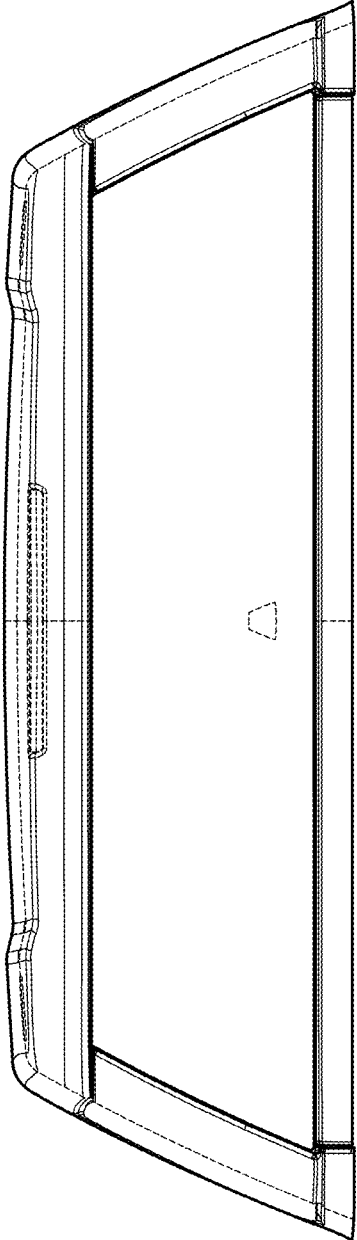

FIG. 9

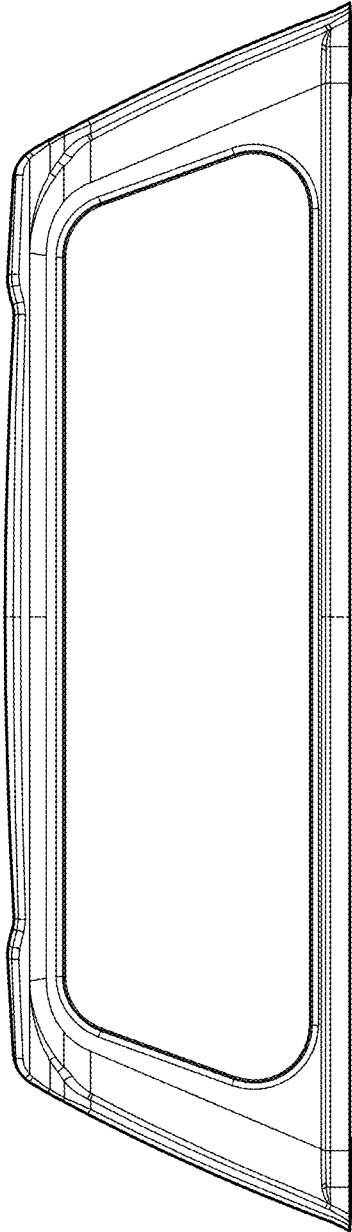

FIG. 10