

(19) World Intellectual Property
Organization
International Bureau



(43) International Publication Date
29 December 2005 (29.12.2005)

PCT

(10) International Publication Number
WO 2005/123167 A1

- (51) International Patent Classification⁷: **A61M 25/00**
- (21) International Application Number:
PCT/US2005/020927
- (22) International Filing Date: 14 June 2005 (14.06.2005)
- (25) Filing Language: English
- (26) Publication Language: English
- (30) Priority Data:
10/871,677 14 June 2004 (14.06.2004) US
- (71) Applicant (for all designated States except US):
BIOSENSE WEBSTER [US/US]; 333 Diamond Canyon
Road, Diamond Bar, California 91765 (US).
- (72) Inventor; and
- (75) Inventor/Applicant (for US only): **MCDANIEL, Ben-
jamin, D.** [US/US]; 615 Marygold, Corona Del Mar, Cali-
fornia 92265 (US).
- (74) Agents: **JOHNSON, Philip, S.** et al.; Johnson & Johnson,
One Johnson & Johnson Plaza, New Brunswick, New Jer-
sey 08933 (US).
- (81) Designated States (unless otherwise indicated, for every
kind of national protection available): AE, AG, AL, AM,
AT, AU, AZ, BA, BB, BG, BR, BW, BY, BZ, CA, CH, CN,
CO, CR, CU, CZ, DE, DK, DM, DZ, EC, EE, EG, ES, FI,
GB, GD, GE, GH, GM, HR, HU, ID, IL, IN, IS, JP, KE,
KG, KM, KP, KR, KZ, LC, LK, LR, LS, LT, LU, LV, MA,
MD, MG, MK, MN, MW, MX, MZ, NA, NG, NI, NO, NZ,
OM, PG, PH, PL, PT, RO, RU, SC, SD, SE, SG, SK, SL,
SM, SY, TJ, TM, TN, TR, TT, TZ, UA, UG, US, UZ, VC,
VN, YU, ZA, ZM, ZW.
- (84) Designated States (unless otherwise indicated, for every
kind of regional protection available): ARIPO (BW, GH,
GM, KE, LS, MW, MZ, NA, SD, SL, SZ, TZ, UG, ZM,
ZW), Eurasian (AM, AZ, BY, KG, KZ, MD, RU, TJ, TM),
European (AT, BE, BG, CH, CY, CZ, DE, DK, EE, ES, FI,
FR, GB, GR, HU, IE, IS, IT, LT, LU, MC, NL, PL, PT, RO,
SE, SI, SK, TR), OAPI (BF, BJ, CF, CG, CI, CM, GA, GN,
GQ, GW, ML, MR, NE, SN, TD, TG).
- Published:**
— with international search report
- For two-letter codes and other abbreviations, refer to the "Guid-
ance Notes on Codes and Abbreviations" appearing at the begin-
ning of each regular issue of the PCT Gazette.

(54) Title: CATHETER GRIP

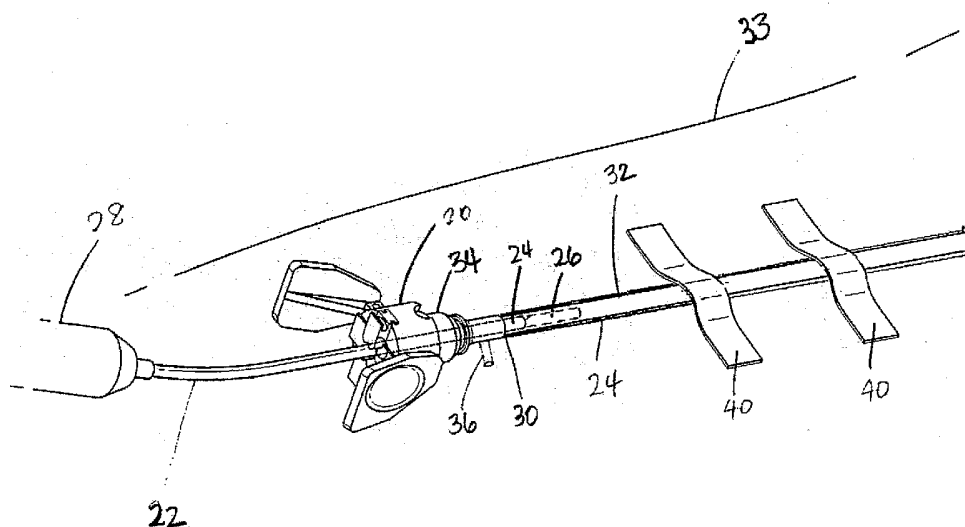

(57) Abstract: A catheter grip adapted to couple with an introducer or sheath holds a catheter in position while in use in a patient's body. The grip has a hub defining a channel through which the catheter extends. The hub has a pair of grip members that work with each other to hold the catheter body between them, a pair of separators to release the catheter body, and a pair of tabs for the doctor to actuate the separators. Each pair of the grip members and the separators is situated on a different diameter of a surface that extends across the channel. Each grip member and separator is diametrically opposed to its mate and movement between the grip members and separators are coordinated in that as the grip members move toward each other, the separators move away from each other, and vice versa.

WO 2005/123167 A1

1

CATHETER GRIP

5 FIELD OF INVENTION

This invention relates to catheters and catheter accessories, particularly, a device that holds a catheter in position while in use in a patient's body.

BACKGROUND OF THE INVENTION

10 Electrode catheters have been in common use in medical practice for many years. They are used to stimulate and map electrical activity in the heart and to ablate sites of aberrant electrical activity. In use, an electrode catheter is inserted into a major vein or artery, e.g., femoral artery, and then guided into the chamber of the heart which is of concern. The catheter should preferably be deflectable to permit proper positioning of the electrodes on its distal end within the heart.

15 Deflectable tip electrode catheters are well known. Such a catheter generally has a control handle at its proximal end for controlling deflection of the tip in one or more directions. For example, a particularly useful deflectable tip catheter is disclosed in U.S. Pat. No. Re. 34,502 to Webster, the disclosure of which is hereby incorporated by reference. This catheter comprises a puller wire that extends on-axis through an elongated reinforced catheter body and then off-axis in a deflectable tip portion. In this arrangement, longitudinal movement of the puller wire relative to the catheter body results in deflection of the catheter tip portion. Other examples of steerable catheters can be found in U.S. Pat. No. 5,431,168 to Webster entitled "Steerable Open-Lumen Catheter" and U.S. patent application Ser. No. 08/924,611 to Webster entitled "Omni-Directional Steerable Catheter," the disclosures of which are hereby incorporated by reference.

25 One drawback to catheters and perhaps especially deflectable catheters is the difficulty of maintaining a catheter in position while in the patient's body. That is, once a suitable tissue site has been located for treatment or evaluation, such as mapping, ablation or the like, the physician is often caught in a predicament with maintaining at least one hand on the catheter while attempting to record or otherwise mark the location of the tissue site. The problem may be greater with deflectable catheters which can store torsional energy and therefore unwind and shift when released from the doctor's grasp. With the heart chamber being a dynamic environment surrounded by moving tissue and blood flow, the target site, which may be relatively small to begin with, can be readily lost with the slightest movement in the catheter.

30 Because a catheter is typically used with an introducer or a sheath which facilitates the catheter's entry into the patient's body, it would be desirable to provide a catheter grip that attaches to the introducer. Often with one hand already working the introducer, an attending doctor could then

1

readily use that same hand to operate the catheter grip. Moreover, it would be desirable to bias the grip toward a closed or gripping configuration so that actuation of the grip involves minimal action on behalf of the doctor.

5

SUMMARY OF THE INVENTION

10

The present invention is directed to a catheter grip adapted to couple with an introducer or sheath and hold a catheter in position while in use in a patient's body. In one embodiment, the grip, which frees the hands of the attending doctor once he has located and placed the catheter in position, includes a hub defining a channel through which the catheter extends. The grip includes components for gripping the catheter, and components to release the catheter.

15

To reach a target site within the patient's body, an elongated body of a catheter is passed through the channel and through the coupled introducer into the patient's vein. The hub has a pair of grip members that work with each other to hold the catheter body between them, a pair of separators to release the catheter body, and a pair of tabs for the doctor to actuate the separators. Each pair of the grip members and the separators is situated on a different diameter of a surface that extends across the channel, such that the pairs of grip members and separators are offset from each other by a predetermined angle and each grip member and separator is diametrically opposed to its mate.

20

25

In one embodiment, the grip members and the separators are movable on tracks configured on the surface in alignment with the two diameters. The tracks have a female fitting portion which receives a male fitting portion configured on each grip member and separator and enables each grip member and each separator to move toward and away from its mate across the channel. The predetermined angle offset between the tracks optimizes the wedge action of the separators on the grip members in separating the grip members to release the catheter body.

30

In another embodiment, the grip members are biased by an elastic member to move toward each other to clamp the catheter body. Interfacing ends of the grip members are notched and have a friction-inducing surface for a more secure hold on the catheter body. Moreover, interfacing ends of the grip members and the separators may be angled to facilitate the leverage action of the separators on the grip members.

35

BRIEF DESCRIPTION OF THE DRAWINGS

1

Fig. 1 is a perspective view of an embodiment of a catheter grip of the present invention for use with an introducer (or sheath) and a catheter.

5

Fig. 2 is an exploded view of the grip of FIG. 1

Fig. 3 is rear view of the grip of FIG. 1, the grip being shown in the closed position.

10

Fig. 4 is a top view the grip of FIG. 1, the grip being shown in the closed position.

Fig. 5 is a side view of the grip of FIG. 1, with parts broken away for clarify, the grip being shown in the closed position.

15

Fig. 6 is a perspective frontal view of the grip of FIG. 1, with parts broken away for clarity, the grip being shown in the closed position.

Fig. 7 is a perspective frontal view of the grip of FIG. 6, the grip being shown in the open or release position.

20

DETAILED DESCRIPTION OF THE INVENTION

FIG. 1 illustrates a catheter grip **20** in accordance with an embodiment of the present invention. The grip **20** is adapted to releasably grip and hold a catheter **22** in use in a patient's body for treatment or evaluation, such as mapping, ablation and the like. Once it is clamped on the catheter, the grip **20** effectively minimizes, if not prevents, the catheter from moving or shifting within the patient's body. As such, the grip **20** frees the hands of the attending doctor once he has closed the grip on the catheter. For purposes of the discussion herein, the catheter **22**, as with most conventional catheters, has the elongated catheter body **24** that extends between a catheter tip section **26** and a control handle **28**. The catheter body **22** and the catheter tip **26** are portions that generally enter the patient's body, whereas the control handle **28** remains outside the body.

30

The catheter grip **20** is adapted for use with an introducer or sheath **30** having a tubular needle **32** that is inserted into a patient's vein or artery, typically in a leg **33**. Introducers, sheaths are generally known and can take on many different configurations. Most have a valve **34** that is provided at the proximal end of the needle. The valve may or may not have a side port **36** for the introduction of

35

1

a fluid to the entry site of the tubular needle **32**. Accordingly, the introducer or sheath (used interchangeably herein) is generally used to facilitate the entry of the catheter tip **26** (not shown) and
5 body **24** into the vein by providing a prepared portal into the patient's body through the valve **34** and the needle **32**.

10

15

20

Referring FIGS. 1 and 2, the grip **20** is configured as a cylinder or barrel which functions in part as a coupling hub **38** that attaches to the proximal end of the valve **34** before or, more preferably, after the introducer **30** has already been inserted and secured to the patient by conventional methods, such as medical tape and bandages **39**. The valve **34** and the hub **38** are releasably coupled to the extent that inadvertent detachment is avoided but intentional decoupling is facilitated. In that regard, the valve and the hub can be snap-fitted, threaded, latched together and/or detachably coupled by other similar methods. In the illustrated embodiment, the valve and hub are frictionally engaged by means of a female fitting formed in the proximal end of the valve and a closely-conforming male fitting formed in the distal end of the hub. It is understood by one of ordinary skill in the art that the configuration, shape and/or size of the hub and the valve can vary. The grip **20** is preferably constructed of a suitably rigid material (including plastic, steel, synthetic or natural rubber, and the like, or combinations thereof) to accomplish its function of holding and maintaining the catheter in position in the patient's body.

25

30

With the introducer **30** secured to the patient's body and the grip **20** coupled to the introducer at its proximal end, the catheter tip **26** and body **24** can be inserted through the grip and the coupled introducer for entry into the patient's body further through the needle **32**. As best shown in FIGS. 2-3, the hub **38** is also configured with a channel **40** that extends between a distal end **42** and a proximal end **44**, the latter of which has an aperture **46** formed in an end wall **48** that extends across the channel. The aperture **46** and the hub **38** are generally concentric about an axis **50** through the channel **40** and each is configured to permit the passing and generally free movement of the catheter tip section **26** and body **24** distally and proximally through the channel **40**.

35

In the illustrated embodiment, the grip **20** includes a pair of grip members **52** situated on a proximal surface **54** of the wall **48**. The grip members **52** are aligned along a diameter **56** of the proximal surface **54** and face each other from across the aperture **46**. In accordance with the present invention, the grip members **52** can move radially inward toward each other to clamp onto the catheter body **24** extending through the aperture **46** and the channel **40**. To facilitate this movement, the grip members **52** travel on a first track **58** formed in the proximal surface **54** along the diameter **56**, which

1

is illustrated with a generally vertical orientation. The grip members **52** and the track **58** are engaged with each other by means of corresponding male and female fitting portions. Referring also to FIG. 4, the disclosed embodiment of the track **58** has a slot **60** with a T-shaped cross-section **62** which receives a ridge **64** with a T-shaped cross-section **66** formed in a distal surface **68** of each grip member **52**. Guided by the track **58**, the grip members **52** are slidable inwardly and outwardly along the diameter **56**.

10

It is understood that the aperture **46** itself need not be (and is not) physically affected by movement of the grip members **52**. It is therefore also understood that the aperture may be configured at any location along the length of the channel **40** and that the grip members **52** need not be in close proximity to nor proximal of the aperture **46**. However, because the aperture **46** can guide the travel path of the catheter body **24** in the channel, it may be preferable in most instances that the grip members **52** and the aperture **46** be configured at least adjacent to each other along the channel **40**. In the illustrated embodiment, the grip members and the aperture are in close proximity of each other and the grip members are immediately proximal of the aperture.

15

Referring to FIGS. 2 and 6, an inner end **70** of each grip member **52** is configured with a notch **72** so that the pair can have a more secure hold on the catheter body **24** between them. In particular, the notch **72** provides better conformity between the interfacing inner ends **70** and the circumference of the catheter body **24**. Depending on the size, flexibility and/or elasticity of the catheter body, the inner ends (notched or otherwise) may or may not be in contact with each other when the grip members **52** are clamped on the catheter body **24**. In any case, the grip members **52**, having a greater frictional contact with the catheter body as provided by the notches, minimize if not prevent translational or rotational movement in the catheter body once released from the hands of the doctor. To that end, surface **74** of the notches **72** may be textured and/or covered with a friction-inducing material **76** (not shown). Once closed, the grip **20** is "hands-free" in minimizing the need for the doctor to hold the catheter body **24** in position for fear that the catheter may shift or move out of position.

20

25

30

In accordance with the present invention, the grip members **52** "rest" in a closed (or grip) position, as shown in FIGS. 3 and 6, under the bias of an elastic member or band **78** shown in FIG. 2. The elastic member sits in a groove **80** configured in an outer section **82** of each grip member **52**. The elastic member **78** exerts around its circumference a force directed radially inward such that the grip members **52** are under a predetermined bias to move toward (if not to make contact with) each other and/or remain in the closed position until actively opened by the user.

35

1

To open the grip members **52**, the grip has a pair of separator or wedgers **84** that are also situated on the proximal face **54** but along a diameter **86** that is offset between about 60-120 degrees, and more preferably about 90 degrees, from the diameter **56** of the grip members **52**. Like the grip members, the wedgers **84** face each other from across the aperture **46** and can move toward and away from each other. In accordance with the present invention, the catheter body **24** is released by the grip **20** when the grip members **52** are separated or driven away from each other, that is, radially outward, by the wedgers **84**, as shown in FIG. 7. To facilitate this action, the wedgers **84** travel along a track **88** also formed in the proximal surface **54** along the diameter **86**, best seen in FIG. 5, with a generally horizontal orientation. The wedgers **84** and the track **88** are engaged with each other by similar means of a male and female fitting portion. In the illustrated embodiment, the track **88** has a slot **90** with a T-shaped cross-section **92** which receives a ridge **94** with a T-shaped cross-section **96** formed in a distal surface of each wedge **84**. Guided by the track **88**, the wedgers **84** can slide inwardly and outwardly along the diameter **86** of the surface **54**. And, because the wedgers **84** and the grip members **52** interact and are interdependent, as described below in further detail, they have portions that affect and/or contact each other and are therefore in close proximity of each other within the grip.

The wedgers **84**, as the name implies, serve to wedge between and drive apart the grip members **52** in releasing the latter's hold on the catheter body **24**. Inner ends **98** and **100** of the grip members **52** and the wedgers **84**, respectively, are angled or chamfered at their corners **99** and **101**, for example, at an angle ranging between about 30 and 60 degrees, and preferably at about 45 degrees, to facilitate this action. The convergence at the inner ends **100** of the wedgers **84** however is not to a point so the inner ends **100** will not protrude toward the catheter body **24** to the extent they contact or cause interfere with the catheter body **24**.

For optimum leverage between the grip members **52** and the wedgers **84**, the inner ends **98** and **100** can be angled at a complementary angle, for example, where the total of the angles of the inner ends equals about 90 degrees). However, it is understood by one of ordinary skill in the art that the slant or degree of angle of the inner ends may be varied for different efficiencies of operation. For example, a more obtuse angle may offer a different feel or tension in the operation of the grip **20**, than would a more acute angle. Moreover, the angle (which may or may not be identical between the wedge members **84** and the grip members **52**) may also depend on or relate to the offset angle between the tracks **56** and **86**.

1

In any case, the grip members **52** are moved toward each other for a closed or grip position (FIG. 6), and away from each other for a release position (FIG. 7). Correspondingly, the wedge members **84** are moved toward each other for a wedge position (FIG. 7), and away from each other for a separated position (FIG. 6). In view of the foregoing description, it is clear that the movements of the pairs of grip members **52** and wedge members **84** are coordinated and interdependent in a manner whereby one pair moves toward each other as the other pair moves away from each other.

10

Movement of the wedge members **84** toward each other to release the catheter body **24** is actuated primarily by means of a pair of tabs **102** that the user actuates. The tabs are pivotably attached to hinges **104** provided on the hub **38** and situated generally on the diameter **86** in alignment with the wedgers **84**. **The hub may be indexed to facilitate this alignment.** In the illustrated embodiment, the hinges **104** are distal of the surface **54** and the tabs **102** extend slightly proximally from the hub **38** with their free ends **106** separated by a maximum distance which decreases to a minimum distance when the tabs are squeezed together by the user. When squeezed, the tabs act on the wedgers **84** through an angled ridge or cam **108** provided on an inner surface **110** of each tab. As can be seen in FIG. 7, as the free ends **106** approach each other, each cam **108** engages an adjacent wedger **84** to drive it inwardly toward its mate.

20

In accordance with the present invention, the tabs **102** are biased away from each other by leaf springs **112** (best seen in FIGS. 6 and 7) such that the tabs spring apart when the user stops squeezing. The bias of the elastic member **78** around the grip members **52** also tends to urge the wedgers **84** to move away from each other. The wedge members **80** therefore "rest" apart from each other (at their maximum separation) until they are moved toward each other by the tabs. It is understood that the tabs may be biased to spring apart by other means. To that end, the leaf springs **112** may be connected or be integrated a single piece extending across the channel **40** to leverage the tabs **102** against each other so they move in a coordinated manner, that is, similarly and coincidentally.

30

Advantageously, a doctor can use the very hand working the introducer **30** to actuate the tabs **102**, and do so without changing hand position. The grip **20** therefore provides improved ergonomics for the doctor, if not a more versatile working environment in which he has more mobility, or at least more freedom with his hands once the grip **20** is closed on the catheter body **24**.

35

1

As mentioned, the grip **20** rests in the closed position, with the grip members **52** being in contact with each other under the bias of the elastic member **78** and the wedgers **84** separated and generally free from compression by the tabs **102** (FIG. 3). By squeezing the tabs **102**, the doctor opens the grip **20** so that he can pass the catheter tip and body through the aperture **46** and into the introducer **30**. As long as the tabs **102** are squeezed, the cams **108** press on the wedgers **84** inwardly keeping the grip members **52** wedged apart. The catheter body **24** can then be advanced by rotation or translation to the grip **20** as needed to reach the target site inside the patient's body (FIG. 7).

10

After the target site has been reached and the catheter body **24** is in position, the doctor releases the tabs **102** which separate under the force of the leaf spring **112**. Without any compressive force pushing the wedgers **84**, they are forced outwardly by the inwardly-moving grip members **52** acting under the force of the elastic member **78** which clamps the grip members **52** on the catheter body **24** (FIG. 6). The notches **72** close around the circumference of the catheter body and the friction-inducing surface **74** securely holds the catheter body **24** to resist sliding or twisting caused by any torsional or coiled energy stored in the catheter body. To adjust or reposition the catheter body **24**, the doctor re-squeezes the tabs **102** to re-separate the grip members **52**. Indeed, release of the grip **20** to separate the grip members **52** at any time can be momentary or of a longer duration as desired by the doctor.

20

It is understood by one of ordinary skill in the art that configuration of the grip and its components can be varied. For example, the grip can be biased toward the open position, such that a band acts to close the wedge members with a leaf spring and/or the tabs separating the grip members. Furthermore, the tabs may be take on a different shape or extend from the hinge at a different angle.

25

The preceding description has been presented with reference to presently preferred embodiments of the invention. Workers skilled in the art and technology to which this invention pertains will appreciate that alterations and changes in the described structure may be practiced without meaningfully departing from the principal, spirit and scope of this invention.

30

Accordingly, the foregoing description should not be read as pertaining only to the precise structures described and illustrated in the accompanying drawings, but rather should be read consistent with and as support to the following claims which are to have their fullest and fair scope.

35

1

WHAT IS CLAIMED IS:

5

1. A grip for use with a catheter having an elongated catheter body, comprising:

a hub with a channel through which the catheter body can extend, the hub having a surface extending across the channel;

10

a first track configured along a first diameter of the surface, a second track configured along a second diameter of the surface, said first and second diameters being angularly offset from each other;

15

a pair of grip members adapted to move toward each other along said first track and hold between them the catheter body;

a pair of separators adapted to move toward each other along said second track and separate the grip members to release the catheter body; and

20

a pair of actuators configured to drive the separators toward the grip members in response to manipulation by a user.

25

2. A catheter grip of claim 1, wherein the actuators are biased against driving the separators toward the grip members.

3. A catheter grip of claim 1, wherein the grip members move toward each other as the separators move away from each other.

30

4. A catheter grip of claim 1, wherein the separators move toward each other as the grip members move away from each other.

5. A catheter grip of claim 1, further comprising a bias member biasing the grip members toward each other.

35

6. A catheter grip of claim 1, wherein said tracks are angularly offset at a predetermined angle of about 90 degrees.

1

7. A catheter grip of claim 1, wherein said surface is formed on a wall extending across the channel, the wall having an aperture through which the catheter body extends.

5

8. A catheter grip of claim 1, wherein the hub is adapted to be coupled with an introducer or sheath.

10

9. A catheter grip of claim 1, wherein one of the first track and the grip members has a male engagement portion that is received in a corresponding female engagement portion in the other of the first track and the grip members.

15

10. A catheter grip of claim 1, wherein one of the second track and the separators has a corresponding male engagement portion that is received in a corresponding female engagement portion in the other of the first track and the separators.

11. A catheter grip of claim 1, wherein inner ends of the separators and the grip members are angled.

20

12. A catheter grip of claim 1, wherein inner ends of the grip members have a notch.

13. A grip for use with a catheter having an elongated catheter body, comprising:

25

a hub with a channel through which the catheter body can extend, the hub adapted to be coupled with an introducer or a sheath;

first opposing means to grip the catheter body within the channel;

30

second opposing means adapted to release the catheter body from the first means; and

actuating means responsive to a user to actuate said second means.

35

14. A grip of claim 13, wherein said first opposing means comprises a pair of grip members that are adapted to hold between them the catheter body.

1

15. A grip of claim 13, wherein said second opposing means comprises a pair of wedge members that are adapted to separate the first opposing means.

5

16. A grip of claim 13, wherein the third means are adapted to drive said second means between said first means to release the catheter body from the grip.

10

17. A grip of claim 13, further comprises means for biasing the first means toward hold the catheter body.

18. A grip of claim 13, further comprises means for biasing the actuation means against actuation of the second means.

15

19. A grip for use with a catheter having an elongated catheter body, comprising:

a hub with a channel through which the catheter body can extend, the hub having a surface extending across the channel, the hub adapted to couple with an introducer or a sheath;

20

a first track configured along a first diameter of the surface, a second track configured along a second diameter of the surface, said first and second diameters being generally perpendicular to each other;

25

a pair of grip members adapted to move toward each other along said first track and hold between them the catheter body;

a pair of separators adapted to move toward each other along said second track to separate the grip members and release the catheter body; and

30

a pair of actuators responsive to manipulation by a user to drive the separator toward the grip members, each actuator having a cam surface acting on an outer end of a different separator;

wherein the grip members are biased toward each other and the actuators are biased against driving the separators toward the grip members.

35

1

20. A grip of claim 19, wherein the grip is coupled to a proximal end of the introducer or sheath.

5

21. A grip of claim 19, wherein the actuators are adapted to be squeezed toward each other by the user.

10

22. A grip of claim 19, wherein the surface is configured on a wall extending across the channel, the wall having an aperture through which the catheter body extends.

23. A grip of claim 22, wherein the wall is at a proximal end of the hub and the grip members and the separators are proximal of the aperture.

15

24. A grip of claim 21, wherein the actuators are hinged to the hub generally along the second diameter.

20

25. A grip of claim 24, wherein the actuators are configured to be manipulated by one hand of the user.

25

30

35

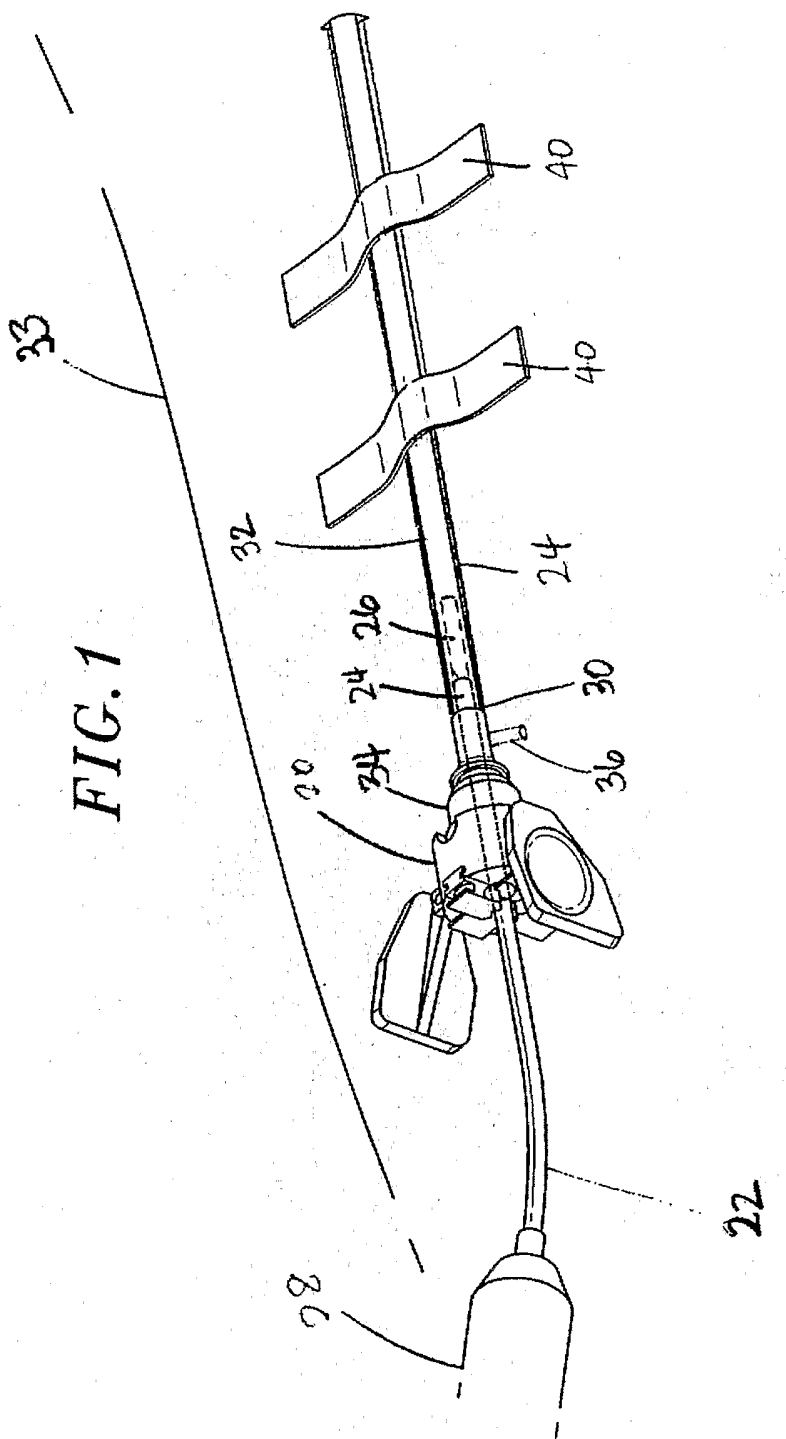

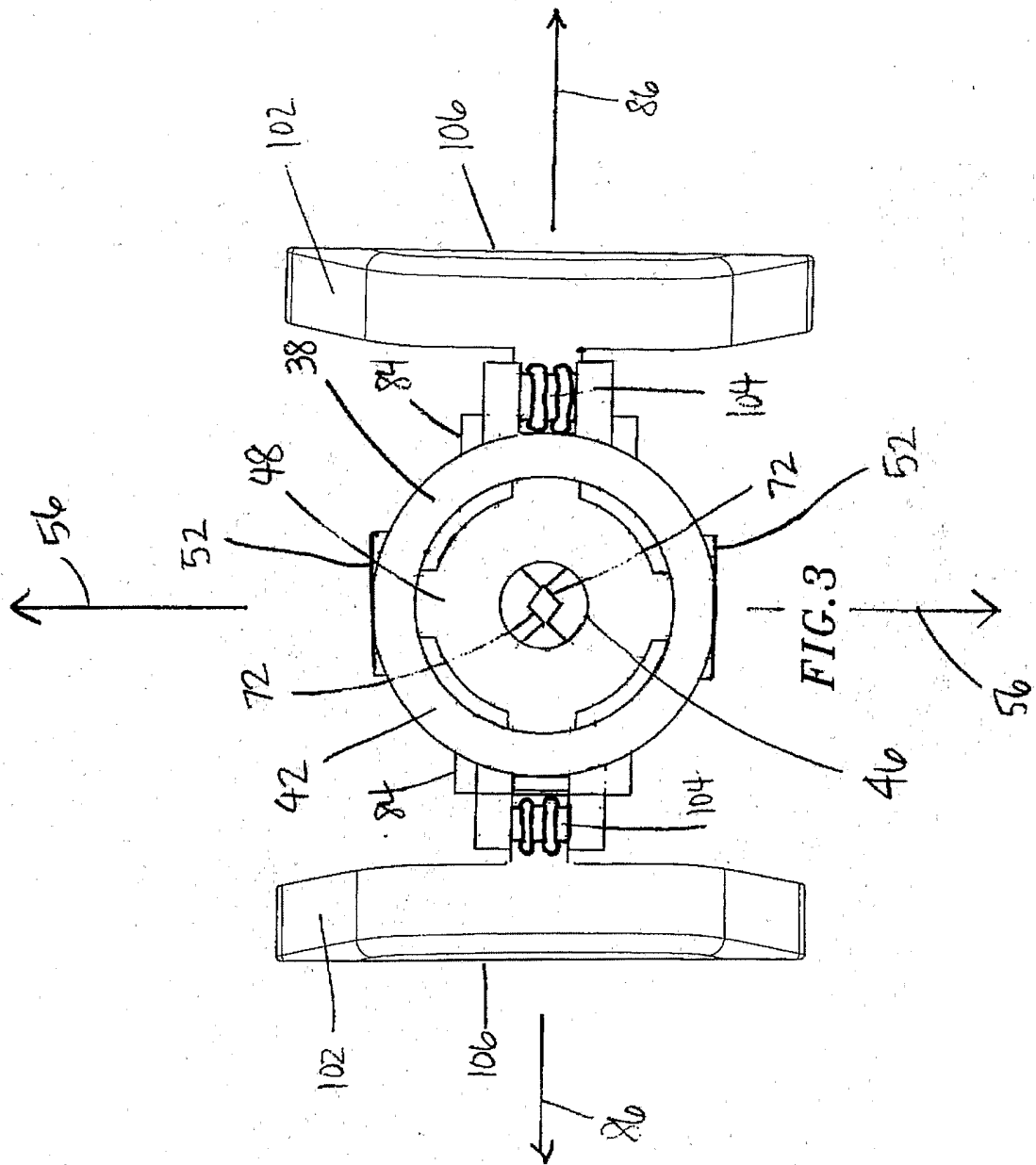

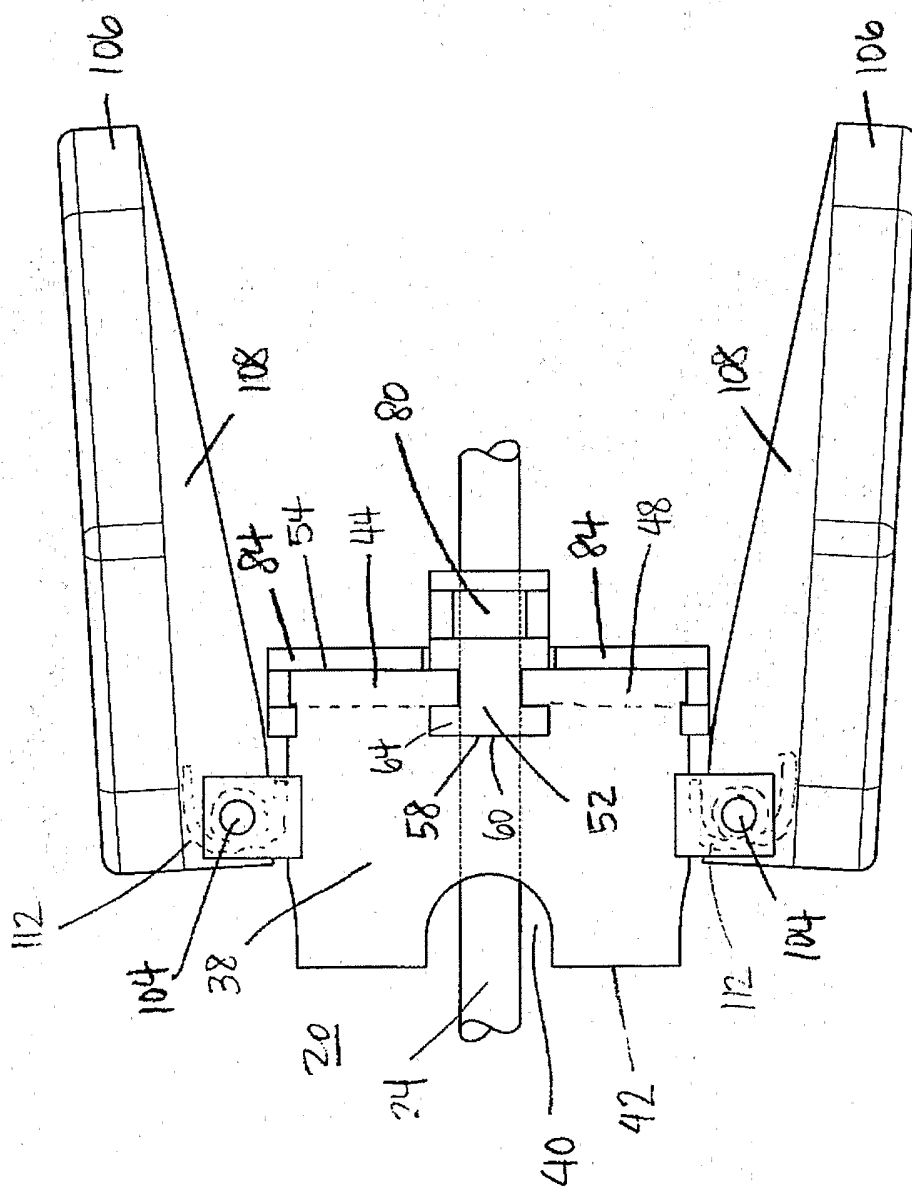
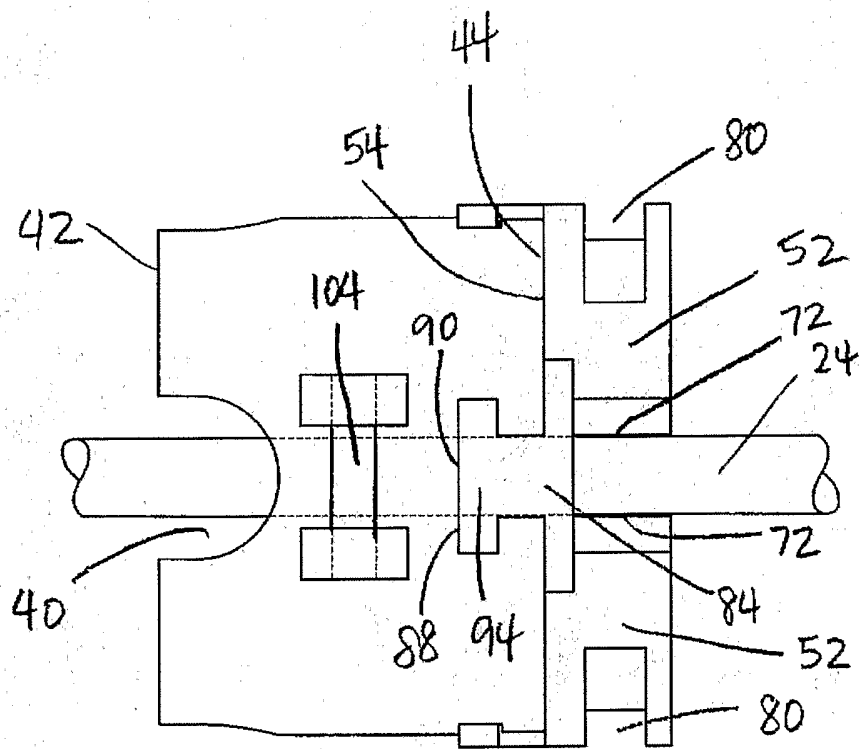

FIG. 4



20

FIG. 5

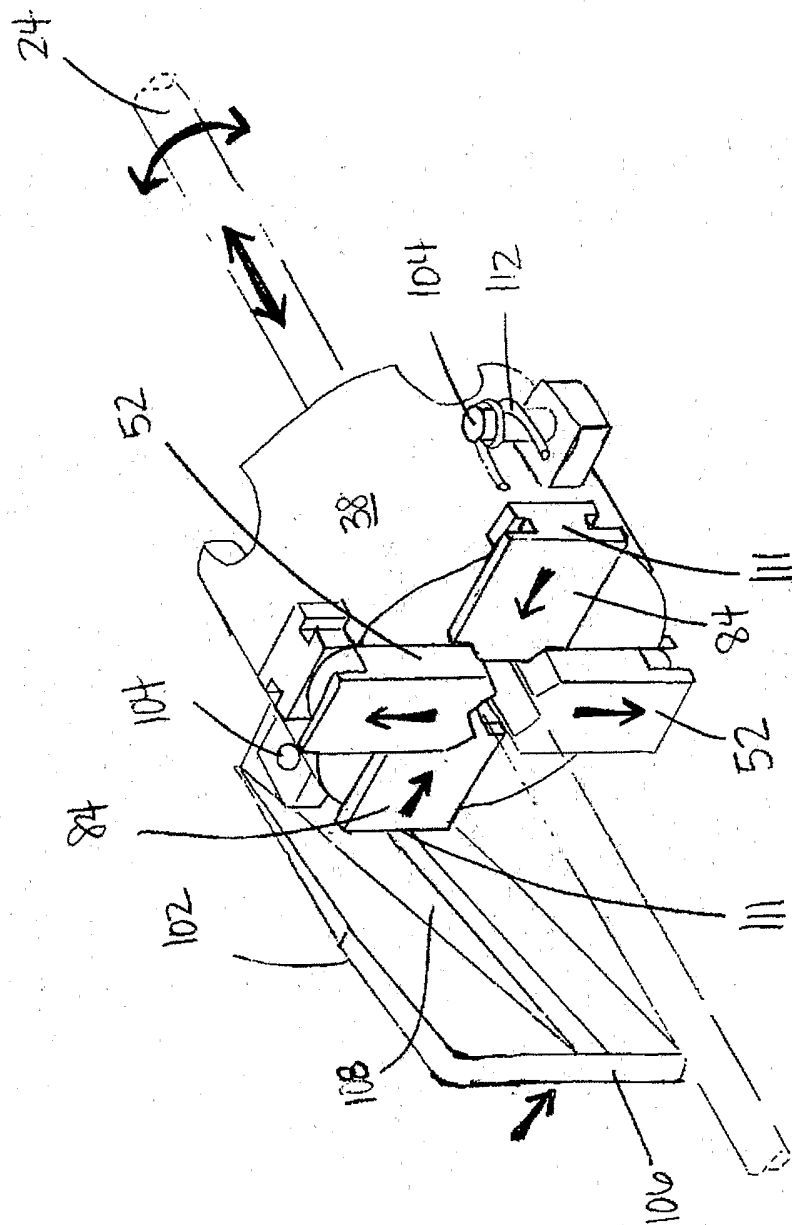

FIG. 7

INTERNATIONAL SEARCH REPORT

PCT/US2005/020927

A. CLASSIFICATION OF SUBJECT MATTER IPC 7 A61M25/00		
According to International Patent Classification (IPC) or to both national classification and IPC		
B. FIELDS SEARCHED		
Minimum documentation searched (classification system followed by classification symbols) IPC 7 A61M		
Documentation searched other than minimum documentation to the extent that such documents are included in the fields searched		
Electronic data base consulted during the international search (name of data base and, where practical, search terms used) EPO-Internal, WPI Data, PAJ		
C. DOCUMENTS CONSIDERED TO BE RELEVANT		
Category °	Citation of document, with indication, where appropriate, of the relevant passages	Relevant to claim No.
A	US 2 234 686 A (WALTER CHARLES T) 11 March 1941 (1941-03-11) claim 1; figures 1-4 -----	1-25
A	DE 198 26 746 C1 (SULZER OSYPKA GMBH) 25 November 1999 (1999-11-25) abstract; figure 2 -----	1-25
A	EP 0 422 631 A (ABBOTT LABORATORIES) 17 April 1991 (1991-04-17) abstract; figure 18 -----	1-25
A	US 6 558 354 B1 (HOWELL GLADE H) 6 May 2003 (2003-05-06) abstract; figures 1-3 -----	1-25
<input type="checkbox"/> Further documents are listed in the continuation of box C.		
<input checked="" type="checkbox"/> Patent family members are listed in annex.		
° Special categories of cited documents :		
A document defining the general state of the art which is not considered to be of particular relevance	*T* later document published after the international filing date or priority date and not in conflict with the application but cited to understand the principle or theory underlying the invention	
E earlier document but published on or after the international filing date	*X* document of particular relevance; the claimed invention cannot be considered novel or cannot be considered to involve an inventive step when the document is taken alone	
L document which may throw doubts on priority claim(s) or which is cited to establish the publication date of another citation or other special reason (as specified)	*Y* document of particular relevance; the claimed invention cannot be considered to involve an inventive step when the document is combined with one or more other such documents, such combination being obvious to a person skilled in the art.	
O document referring to an oral disclosure, use, exhibition or other means	*&* document member of the same patent family	
P document published prior to the international filing date but later than the priority date claimed		
Date of the actual completion of the international search <p style="text-align: center;">29 September 2005</p>	Date of mailing of the international search report <p style="text-align: center;">12/10/2005</p>	
Name and mailing address of the ISA European Patent Office, P.B. 5818 Patentlaan 2 NL - 2280 HV Rijswijk Tel. (+31-70) 340-2040, Tx. 31 651 epo nl, Fax: (+31-70) 340-3016	Authorized officer <p style="text-align: center;">Mausser, T</p>	

INTERNATIONAL SEARCH REPORT

PCT/US2005/020927

Patent document cited in search report	Publication date	Patent family member(s)	Publication date
US 2234686	A	11-03-1941	NONE
DE 19826746	C1	25-11-1999	EP 0972536 A1 19-01-2000
EP 0422631	A	17-04-1991	AU 641186 B2 16-09-1993 AU 6458590 A 18-04-1991 CA 2027313 A1 14-04-1991 IE 903598 A1 24-04-1991 JP 3165783 A 17-07-1991 NZ 235604 A 25-02-1994 US 5078703 A 07-01-1992
US 6558354	B1	06-05-2003	AT 284730 T 15-01-2005 AU 7905901 A 18-02-2002 BR 0113030 A 08-07-2003 CN 1527732 A 08-09-2004 DE 60107855 D1 20-01-2005 EP 1305076 A1 02-05-2003 ES 2234865 T3 01-07-2005 JP 2004505691 T 26-02-2004 WO 0211811 A1 14-02-2002