

(19)



(11)

EP 3 150 902 A1

(12)

EUROPEAN PATENT APPLICATION

(43) Date of publication:
05.04.2017 Bulletin 2017/14

(51) Int Cl.:
F21S 6/00 ^(2006.01) **F21V 17/12** ^(2006.01)
F21V 21/26 ^(2006.01)

(21) Application number: **15199970.3**

(22) Date of filing: **14.12.2015**

(84) Designated Contracting States:
AL AT BE BG CH CY CZ DE DK EE ES FI FR GB GR HR HU IE IS IT LI LT LU LV MC MK MT NL NO PL PT RO RS SE SI SK SM TR
 Designated Extension States:
BA ME
 Designated Validation States:
MA MD

(71) Applicant: **SC Smart Furniture Srl**
400393 Cluj-Napoca (RO)

(72) Inventors:
 • **ZALANYI, Bela**
401174 Turda, jud. Cluj (RO)
 • **PITIC, Stefan Lucian**
400492 Cluj-Napoca, jud. Cluj (RO)

(30) Priority: **02.10.2015 RO 201500714**

(54) **FOLDING LAMP WITH LEDS**

(57) The invention relates to a folding LED lamp designed to illuminate a work table.

The folding LED lamp is made up of two or more identical modules (1) and an end module (2) which is equipped with a strip of LEDs (15), the modules (1) consisting of rectangular plates with a cut up (3) at the lower extremity and with a protrusion (4) at the upper extremity, so that the protrusion (4) of a module enters the cut up (3) of the next module, and the end module (2) has at the bottom a cut up (3) for coupling the previous module (1), the blocking of modules being performed by means of a screw (7) with a locking pin (9) in a recess (10) of the circular groove (11), the tightening being carried out by a wing nut (12) with the sleeve (13) that squeezes the protrusion (4) of a module (1) into the cut up (3) of the next module, the modular structure ensuring the flexibility and reconfiguration of the lamp.

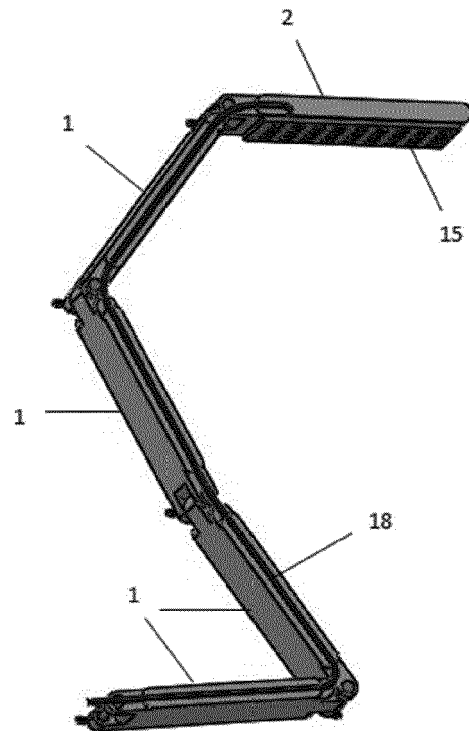

Figure 2

EP 3 150 902 A1

Description

[0001] The invention relates to a folding LED lamp designed to illuminate a work table.

[0002] There are known several solutions for the realization of folding lamps. Thus, the utility model CN201810997 "**Folding small nightlight**" describes a lamp made up of two rectangular frames interconnected through a shaft, the upper frame having at its outer end a support cap for a light bulb, and the connection between the cap and the upper frame being realized by means of a spherical pin electrically conductive so that the cap can be rotated at any angle relative to the frame.

[0003] The lamp cap and the two frames are connected through electric wires embedded in the structural elements of the lamp.

[0004] Further, the invention CN104456368 "**Multi-functional mini folding table lamp**" is known, which shows a table lamp comprising two plates interconnected in a manner that allows them to be folded, one of them being the base while the other has a lighting face. A touch sensitive switch is located in the folding area of the two plates so that, when the lamp is folded, the lamp automatically turns off the light and when the lamp is extended, its light turns on. A lithium battery integrated in the base plate is the electricity source, but the lamp can be additionally supplied from the power cable.

[0005] The invention CN104456256 "**Folding LED table lamp**" describe a folding table lamp, comprising a fixed plate used for attaching to the table, two turning plates, the first being connected to the fixed plate, and a telescopic plate which can slide along a groove made in the rear end of the second plate, the telescopic plate being equipped with a LED lamp. The length of the lamp can be adjusted to meet the user needs.

[0006] The major disadvantage of existing solutions of the technical state of the art is the lack of the possibility to easily reconfigure the lamp by adding or removing modular plates to its structure and / or by changing its shape.

[0007] The technical problem solved by the present invention consist in adapting the size and the shape of a work table lamp in order to fit to the space dimensions and to ensure illumination of different work places, at different times.

[0008] The folding LED lamp according to the invention comprises two or more modules, of a rectangular shape slightly modified by realizing a cutout at one extremity and a protrusion at the other extremity, the modules being interconnected by means of an axle bolt and integrating on their sides electric cables located in circular grooves which feed a LED strip designed for lighting the workspace, with the strip located on one of the two main faces of the end module thus realizing an illuminating surface.

[0009] Further, an example of the invention is described based on the figures 1 - 9 which display:

- Figure 1 - folding lamp - isometric view;

- Figure 2 - folding lamp - perspective view;
 - Figure 3 - folding lamp - side view;
 - Figure 4 - isometric view of a module;
 - Figure 5 - perspective view of a module;
 - Figure 6 - side view of a module;
 - Figure 7 - detail of the assembly system;
 - Figure 8 - bolt for connecting modules;
 - Figure 9 - end module image.

[0010] The folding LED lamp according to the invention comprises two or more modules 1 with identical structure, except for the end module 2.

[0011] Module 1 has a slightly modified rectangular shape with a cut up 3 at the lower end and with a protrusion 4 at the upper end, realized in such a way that the protrusion 4 of a module matches the cut up 3 of the next module in order to fill the space.

[0012] The end module 2 has all the elements of the module 1 except for the protrusion 4 and, additionally, to one of the main faces is applied a LED strip 15 for lighting the workspace.

[0013] At both ends of the module 1 there is a pair of holes 5 and 6, respectively, for connecting the modules. The hole pair 5 can be found also at the lower end of the end module 2. The interconnection of the modules is realized by a screw 7 which goes through the pair of holes 6 of a module and the pair of holes 5 of the next module. The screw 7 has at one end a cylindrical extremity 8 which enters into one of the holes of the pair 5 and a pin 9 which is placed in the slot 10 of the bore 11 made near to the hole 5, in order to prevent the rotation of the screw 7. At the opposite end, the screw 7 has a wing nut 12 which causes a translation motion of the sleeve 13 ensuring the locking of the modules. By loosening the nut 12 the neighboring modules 1 or (1 and 2) can rotate around the screw 7 so that the lamp user can choose the desired relative position of the modules and then to fix it by fastening the nut 12. In this manner, by connecting sequentially the modules there can be achieved the desired lamp structure and position, according to the size of the space in which it is used and on the target location for illuminating.

[0014] The modules 1 and 2 have on one of the lateral faces a cylindrical groove 14 on the entire length of module 1 and in case of the end module 2, only on a small section, through which passes an electric cable 18 for supplying the LED strip 15 applied on one of the main faces of the end module 2.

[0015] The extremities of each module 1 have each a cut up 16 and 17, of length 1 equal to the axis of the bores 5 and 6, which allow the module rotation around the screw 7 avoiding the compression or damage of the electric cable 18.

[0016] Module 2 also has a cut up 15 towards the bottom end of the module for connecting to module 1.

[0017] The extremities of the modules 1 and 2 are rounded to facilitate better tightening of the modules when folding.

[0018] The length of the lamp can be changed as needed by adding or removing modules of type 1.

[0019] The lamp may be placed directly on the work table, or it may be fixed to a stationary or rotating support, not displayed in figures, by means of the screw 7 from the lower extremity of the first module. 5

[0020] By realizing the folding LED lamp the following advantages can be obtained:

- the size lamp can easily be changed when manufactured, but also subsequently, by adding or removing modules; 10
- during lamp use its length can be changed by extending or folding it so that its size matches the available space; 15
- by fixing the modules in certain positions different shapes of the lamp can be obtained from a linear shape, oriented vertically, horizontally or transversally, to various other forms such as Z, S, U, etc.; 20
- the size of the lamp can be minimized during transport by placing modules on top of each other.

Claims

- 25
1. The folding LED lamp made up of two or more modules (1) with screws (7) and wing nuts (12) and an end module (2) equipped with a strip of LEDs (15), **characterized in that** for achieving a flexible and reconfigurable structure, the modules (1) are shaped as rectangular plates with a cut up (3) at the lower extremity and with a protrusion (4) at the upper extremity, so that the protrusion (4) of a module can enter the cut up (3) of the next module, and the end module (2) has at the bottom a cut up (3) for coupling to the previous module (1), the blocking of modules being performed by means of a screw (7) with a locking pin (9) in a recess (10) of the circular groove (11), the tightening being carried out by a wing nut (12) with the sleeve (13) that tightens the protrusion (4) of a module (1) into the cut up (3) of the next module. 30 35 40
 2. The folding LED lamp according to claim 1, **characterized in that** the modules (1) and (2) have shaped on the side faces a cylindrical groove (14), of circular cross-section, where the electric cable (18) is inserted, and to avoid the compression and the damage of the electric cable (18), both ends of each module (1) and the lower end of the module (2) are each equipped with a cut up (16) and (17), of length 1 equal to the axis of the bores (5) and (6), and the modules (1) and (2) are rounded at their extremities to facilitate better tightening of the modules when folding. 45 50 55

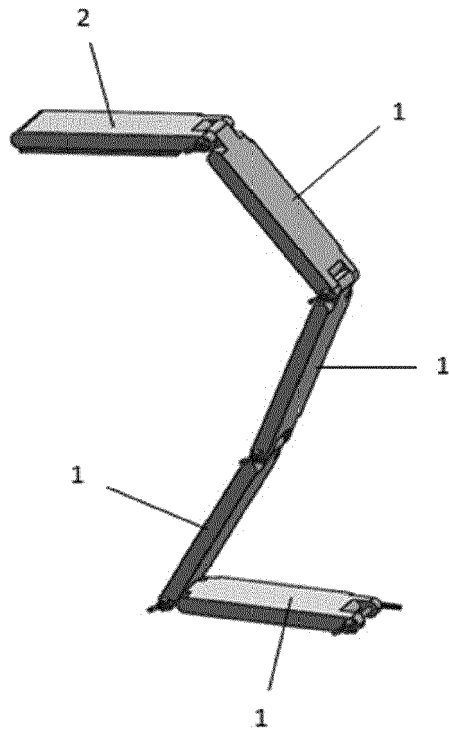

Figure 1

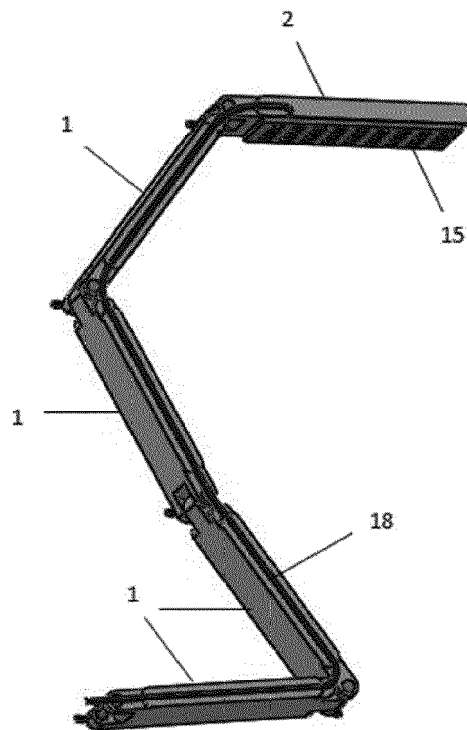

Figure 2

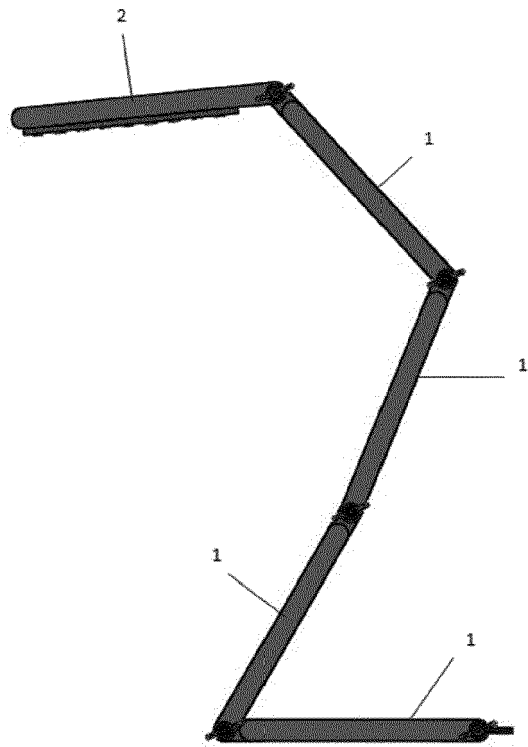

Figure 3

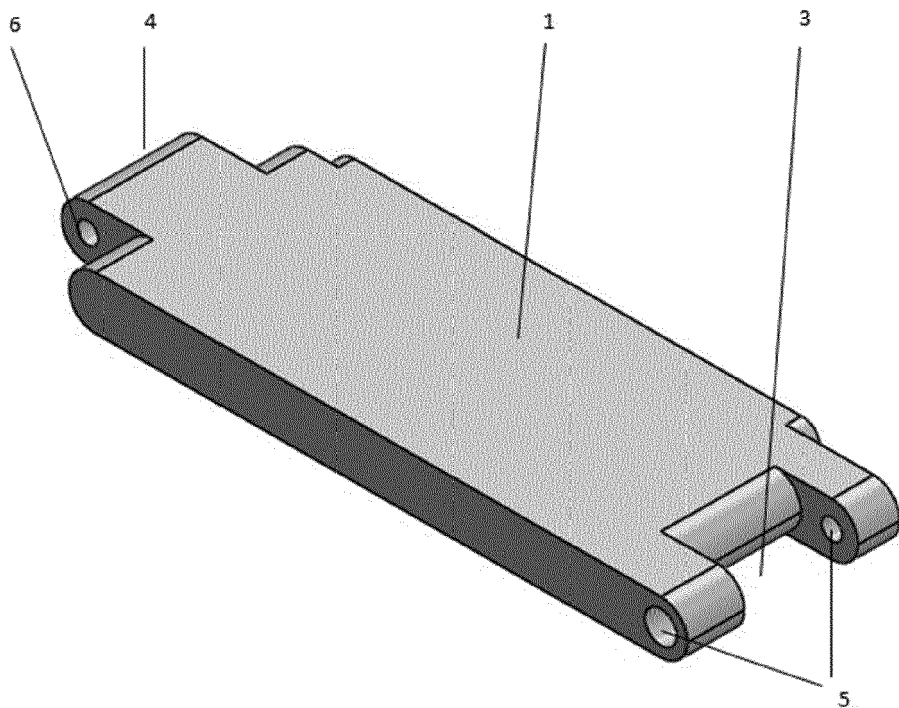

Figure 4

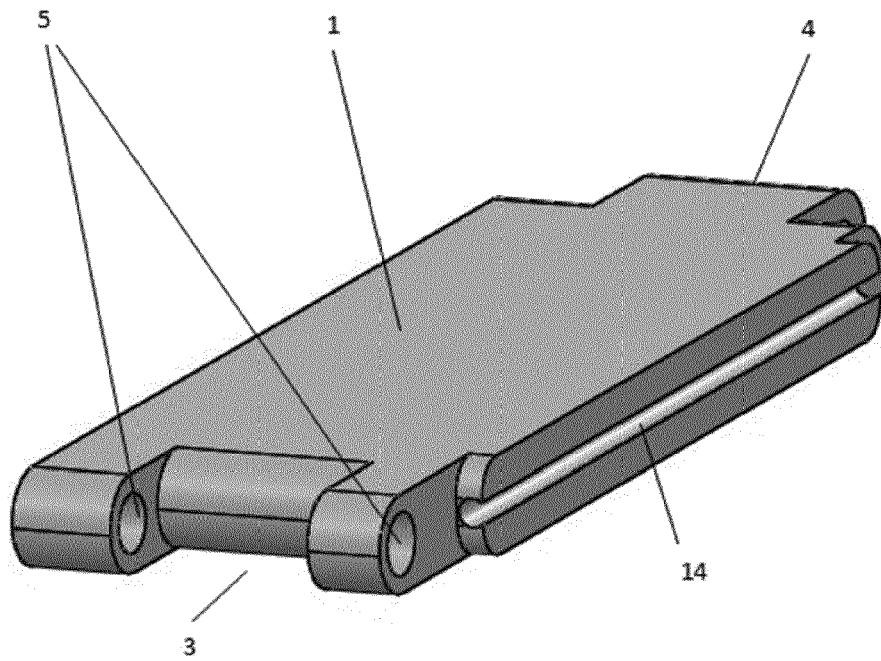

Figure 5

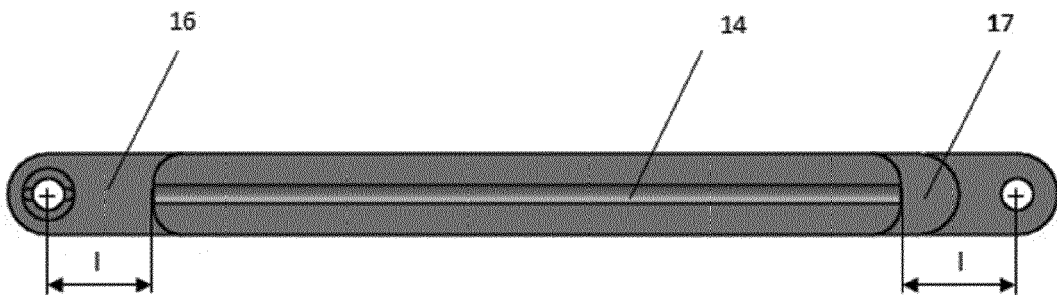

Figure 6

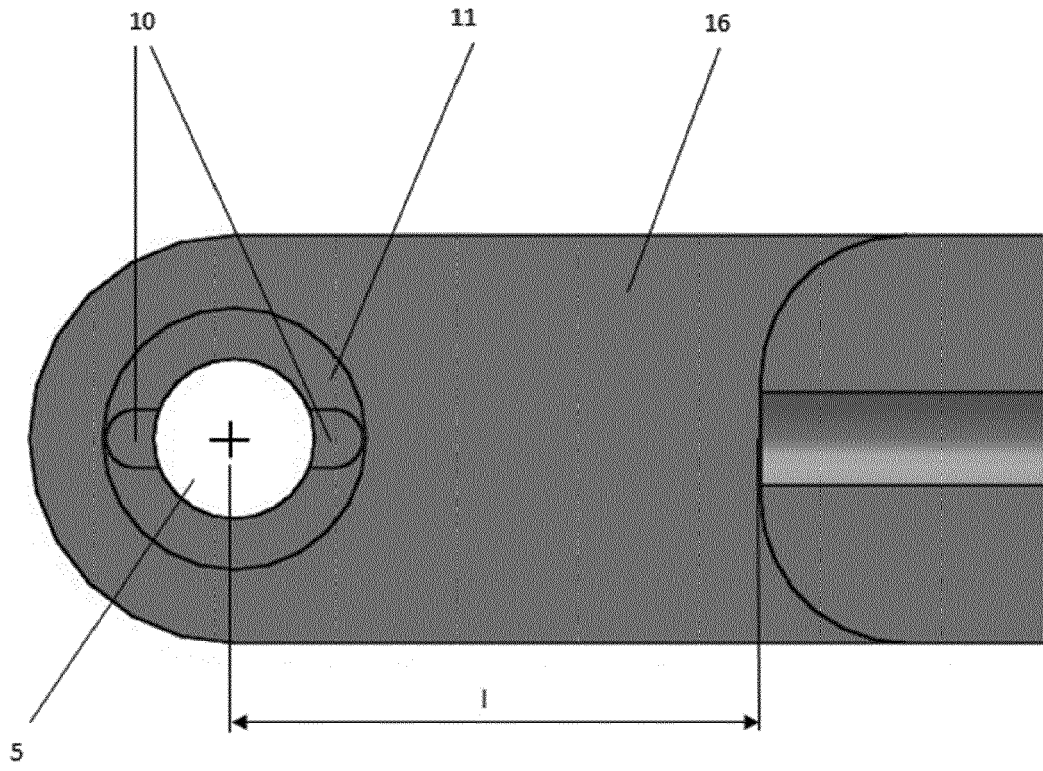

Figure 7

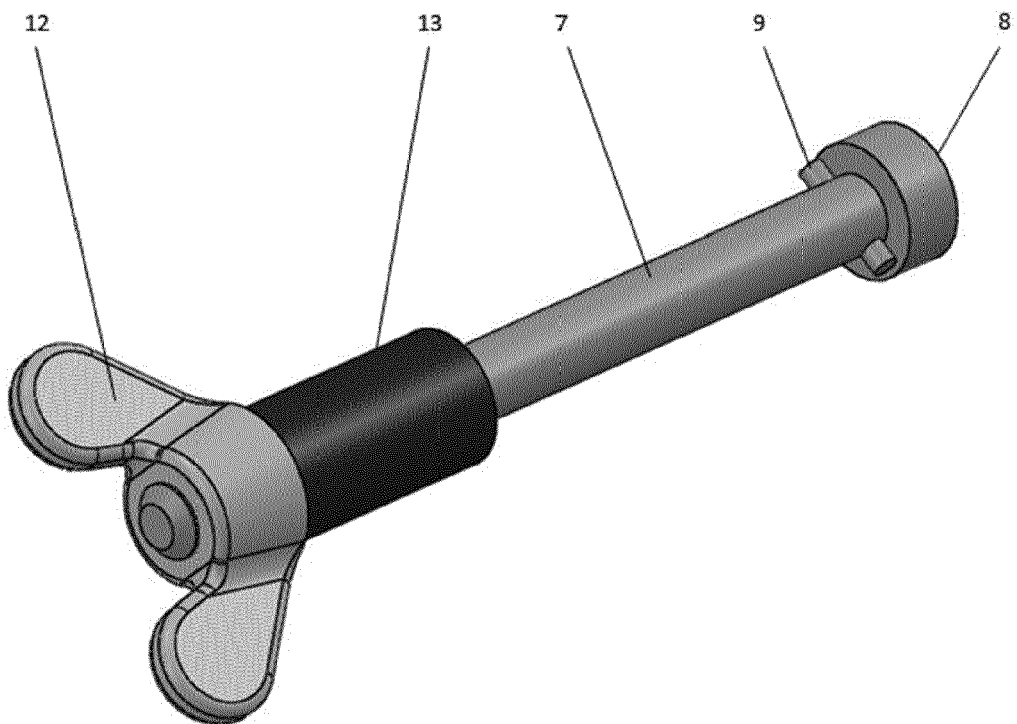

Figure 8

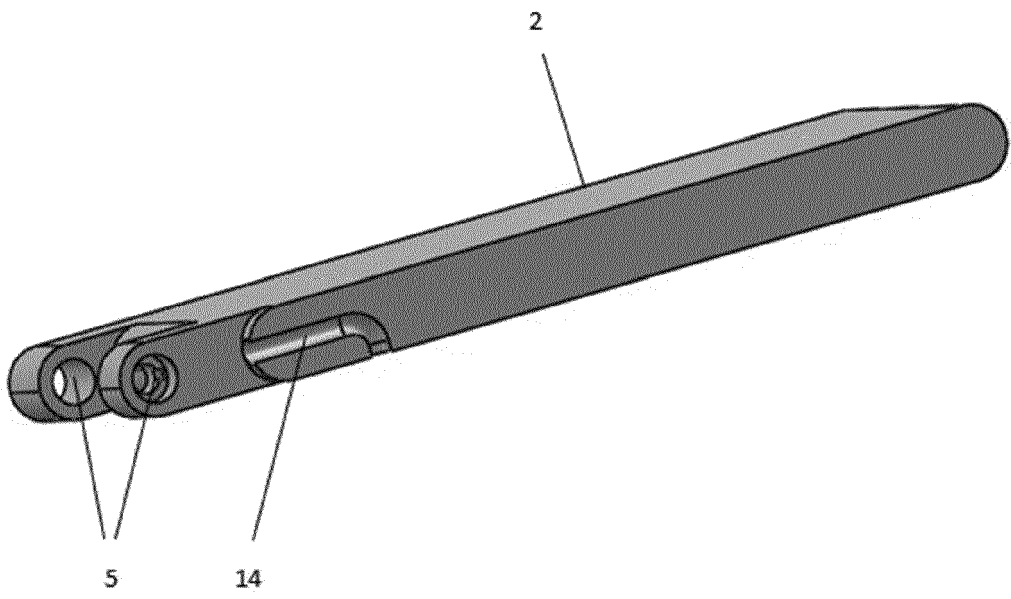

Figure 9



EUROPEAN SEARCH REPORT

Application Number
EP 15 19 9970

5

10

15

20

25

30

35

40

45

50

55

DOCUMENTS CONSIDERED TO BE RELEVANT			
Category	Citation of document with indication, where appropriate, of relevant passages	Relevant to claim	CLASSIFICATION OF THE APPLICATION (IPC)
Y	US 2011/235347 A1 (CHOU CHIA-SHIN [TW] ET AL) 29 September 2011 (2011-09-29) * figures 1-5 * * paragraph [0011] - paragraph [0021] *	1	INV. F21S6/00 F21V17/12 F21V21/26
Y	US 7 441 630 B1 (HERRINGTON DANIEL A [US] ET AL) 28 October 2008 (2008-10-28) * figure 3 *	1	
A	US 2004/105271 A1 (CHEN WEN-TSUNG [TW]) 3 June 2004 (2004-06-03) * figures 2-6 * * paragraph [0021] - paragraph [0034] *	1,2	
A	US 2011/141737 A1 (GU HUI-SHAN [CN] ET AL) 16 June 2011 (2011-06-16) * figures 1-7 * * paragraph [0014] - paragraph [0031] *	1	
A	US 2012/145699 A1 (MCMAHAN ROBERT L [US]) 14 June 2012 (2012-06-14) * figure 3A *	1,2	
A	US 2014/169007 A1 (POLICK PETER [US] ET AL) 19 June 2014 (2014-06-19) * the whole document *	1,2	
A	US 4 770 384 A (KUWAZIMA TAKASHI [JP] ET AL) 13 September 1988 (1988-09-13) * the whole document *	1,2	
A	WO 2014/036342 A1 (AXLEN INC [US]) 6 March 2014 (2014-03-06) * the whole document *	1,2	TECHNICAL FIELDS SEARCHED (IPC) F21S F21V F21Y
The present search report has been drawn up for all claims			
Place of search The Hague		Date of completion of the search 26 April 2016	Examiner Sacepe, Nicolas
<p>CATEGORY OF CITED DOCUMENTS</p> <p>X : particularly relevant if taken alone Y : particularly relevant if combined with another document of the same category A : technological background O : non-written disclosure P : intermediate document</p> <p>T : theory or principle underlying the invention E : earlier patent document, but published on, or after the filing date D : document cited in the application L : document cited for other reasons & : member of the same patent family, corresponding document</p>			

EPO FORM 1503 03/02 (P04C01)

ANNEX TO THE EUROPEAN SEARCH REPORT
ON EUROPEAN PATENT APPLICATION NO.

EP 15 19 9970

5

This annex lists the patent family members relating to the patent documents cited in the above-mentioned European search report. The members are as contained in the European Patent Office EDP file on The European Patent Office is in no way liable for these particulars which are merely given for the purpose of information.

26-04-2016

10

15

20

25

30

35

40

45

50

55

Patent document cited in search report	Publication date	Patent family member(s)	Publication date
US 2011235347 A1	29-09-2011	CN 102207281 A US 2011235347 A1	05-10-2011 29-09-2011
US 7441630 B1	28-10-2008	NONE	
US 2004105271 A1	03-06-2004	NONE	
US 2011141737 A1	16-06-2011	CN 102094894 A US 2011141737 A1	15-06-2011 16-06-2011
US 2012145699 A1	14-06-2012	NONE	
US 2014169007 A1	19-06-2014	NONE	
US 4770384 A	13-09-1988	DE 3766768 D1 EP 0255253 A2 NO 873146 A US 4770384 A	31-01-1991 03-02-1988 29-01-1988 13-09-1988
WO 2014036342 A1	06-03-2014	US 2015267898 A1 WO 2014036342 A1	24-09-2015 06-03-2014

EPO FORM P0459

For more details about this annex : see Official Journal of the European Patent Office, No. 12/82

REFERENCES CITED IN THE DESCRIPTION

This list of references cited by the applicant is for the reader's convenience only. It does not form part of the European patent document. Even though great care has been taken in compiling the references, errors or omissions cannot be excluded and the EPO disclaims all liability in this regard.

Patent documents cited in the description

- CN 201810997 [0002]
- CN 104456368 [0004]
- CN 104456256 [0005]