

(19) World Intellectual Property Organization
International Bureau



(43) International Publication Date
9 December 2010 (09.12.2010)

(10) International Publication Number
WO 2010/140800 A2

(51) International Patent Classification:
F25D 23/00 (2006.01)

Campus, 327-23 Gasan-dong Geumcheon-gu, Seoul 153-802 (KR).

(21) International Application Number:
PCT/KR2010/003455

(74) Agents: KIM, Yong In et al.; KBK & Associates, 7th Floor Hyundai Building, 175-9 Jamsil-dong Songpa-ku, Seoul 138-861 (KR).

(22) International Filing Date:
31 May 2010 (31.05.2010)

(81) Designated States (unless otherwise indicated, for every kind of national protection available): AE, AG, AL, AM, AO, AT, AU, AZ, BA, BB, BG, BH, BR, BW, BY, BZ, CA, CH, CL, CN, CO, CR, CU, CZ, DE, DK, DM, DO, DZ, EC, EE, EG, ES, FI, GB, GD, GE, GH, GM, GT, HN, HR, HU, ID, IL, IN, IS, JP, KE, KG, KM, KN, KP, KZ, LA, LC, LK, LR, LS, LT, LU, LY, MA, MD, ME, MG, MK, MN, MW, MX, MY, MZ, NA, NG, NI, NO, NZ, OM, PE, PG, PH, PL, PT, RO, RS, RU, SC, SD, SE, SG, SK, SL, SM, ST, SV, SY, TH, TJ, TM, TN, TR, TT, TZ, UA, UG, US, UZ, VC, VN, ZA, ZM, ZW.

(25) Filing Language: English

(26) Publication Language: English

(30) Priority Data:
10-2009-0049003 3 June 2009 (03.06.2009) KR

(71) Applicant (for all designated States except US): LG ELECTRONICS INC. [KR/KR]; 20 Yeouido-dong, Yeongdeungpo-gu, Seoul 150-721 (KR).

(72) Inventors; and
(75) Inventors/Applicants (for US only): KWON, Hong Sik [KR/KR]; LG Electronics Inc. Gasan R&D Campus, 327-23 Gasan-dong Geumcheon-gu, Seoul 153-802 (KR). CHANG, Yong Hun [KR/KR]; LG Electronics Inc. Gasan R&D Campus, 327-23 Gasan-dong Geumcheon-gu, Seoul 153-802 (KR). HWANG, Jung Yeon [KR/KR]; LG Electronics Inc. Gasan R&D Campus, 327-23 Gasan-dong Geumcheon-gu, Seoul 153-802 (KR). YU, Seon Il [KR/KR]; LG Electronics Inc. Gasan R&D

(84) Designated States (unless otherwise indicated, for every kind of regional protection available): ARIPO (BW, GH, GM, KE, LR, LS, MW, MZ, NA, SD, SL, SZ, TZ, UG, ZM, ZW), Eurasian (AM, AZ, BY, KG, KZ, MD, RU, TJ, TM), European (AL, AT, BE, BG, CH, CY, CZ, DE, DK, EE, ES, FI, FR, GB, GR, HR, HU, IE, IS, IT, LT, LU, LV, MC, MK, MT, NL, NO, PL, PT, RO, SE, SI, SK, SM, TR), OAPI (BF, BJ, CF, CG, CI, CM, GA, GN, GQ, GW, ML, MR, NE, SN, TD, TG).

[Continued on next page]

(54) Title: REFRIGERATOR

[Fig. 1]

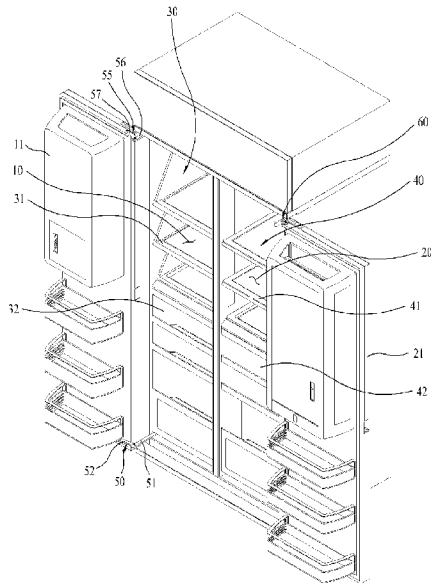

(57) Abstract: A refrigerator includes a cold air generator configured to generate cold air. The refrigerator also includes a storage chamber configured to receive the cold air generated by the cold air generator, and store at least one food and ice stuffs. Further, the refrigerator includes a storage chamber door configured to open and close an access point to the storage chamber. In addition, the refrigerator includes an inner frame coupled to the storage chamber and configured to move at least a part of the storage chamber in forward and backward directions.

WO 2010/140800 A2

Published:

- *without international search report and to be republished upon receipt of that report (Rule 48.2(g))*

Description

Title of Invention: REFRIGERATOR

Technical Field

- [1] The present disclosure relates to a refrigerator.

Background Art

- [2] In general, a refrigerator uses cold air produced as refrigerant vaporizes and absorbs heat from the air.
- [3] In detail, the refrigerant is compressed at a compressor, and forwarded to an evaporator via an expansion valve, where the refrigerant vaporizes. The refrigerant absorbs heat from surroundings in such a vaporizing process, and cools down surrounding air to produce the cold air.
- [4] The cold air is forwarded to the refrigerating chamber or the freezing chamber for maintaining the refrigerating chamber or the freezing chamber to be below a fixed temperature.
- [5] Depending on arrangement of the refrigerating chamber or the freezing chamber, in the refrigerators, there are a top mount-type refrigerator in which the freezing chamber is arranged on the refrigerating chamber, a bottom freezer type refrigerator in which the freezing chamber is arranged under the refrigerating chamber, and a side by side type refrigerator in which the refrigerating chamber and the freezing chamber are arranged side by side. Above categorization is just for convenience's sake, but not absolute ones.
- [6] The bottom freezer type refrigerator has an inside space partitioned with a barrier, an upper side of which is the refrigerating chamber and a lower side of which is the freezing chamber.
- [7] In general, the refrigerating chamber has at least one refrigerating chamber door rotatably mounted thereto to open/close the refrigerating chamber, and the freezing chamber has a drawer structure which is slidably moved back and forth to open/close the freezing chamber.
- [8] In general, in rear of the freezing chamber and the refrigerating chamber, there are the evaporators and fans for blowing the cold air respectively, for generating the cold air individually to control temperatures of the freezing chamber and the refrigerating chamber, respectively.

Disclosure of Invention

Technical Problem

- [9] There are many cases in which structures, such as an ice maker, shelves a home bar and the like, are mounted in an inside wall of a refrigerating chamber door or a

freezing chamber door of a refrigerator. In order to avoid interference with the structures, the shelves and drawers in the refrigerating chamber or the freezing chamber are mounted to an inner side thereof, deeply.

Solution to Problem

- [10] In one aspect, a refrigerator includes a cold air generator configured to generate cold air. The refrigerator also includes a storage chamber configured to receive the cold air generated by the cold air generator, and store at least one food and ice stuffs. The refrigerator further includes a storage chamber door configured to open and close an access point to the storage chamber. In addition, the refrigerator includes an inner frame coupled to the storage chamber and configured to move at least a part of the storage chamber in forward and backward directions.
- [11] Implementations may include one or more of the following features. For example, the refrigerator further includes a drawing out device configured to move the inner frame in connection with opening and closing of the door. The drawing out device includes a link device connected to the door and the inner frame. The link device includes a first link connected to the inner frame and a second link connected to the door. The inner frame includes an upper surface positioned at upper side from a center of the refrigerator and slidably connected to a top wall surface of the storage chamber and a lower surface positioned at lower side from the center of the refrigerator and slidably connected to a bottom wall surface of the storage chamber.
- [12] In some examples, the inner frame includes a top sliding unit slidably connected to a ceiling surface of the storage chamber and a bottom sliding unit slidably connected to a bottom surface of the storage chamber. The at least a part of the storage chamber comprises the plurality of shelves and/or drawers that are mounted in the inner frame. The storage chamber includes at least one of a refrigerating chamber and a freezing chamber. The refrigerator further includes a protector configured to prevent the refrigerator from falling down when the inner frame moves in the forward and backward directions.
- [13] In another aspect, a refrigerator includes a cold air generator configured to generate cold air. The refrigerator also includes a storage chamber having a moving member, configured to receive the cold air generated by the cold air generator, and store at least one food and ice stuffs. The refrigerator further includes a door configured to open and close the storage chamber, wherein the moving member is configured to be moved in forward and backward directions in response to opening and closing of the door.
- [14] Implementations may include one or more of the following features. For example, the moving member includes an inner frame configured to be slidably moved in the forward and backward directions and a moving structure mounted in the inner frame,

and configured to be moved together with the inner frame. The moving structure includes at least one a shelf and a drawer. The refrigerator further includes a drawing out device configured to move the moving member responsive to opening and closing of the door. The drawing out device includes a link device connected to the door and the inner frame.

- [15] In some examples, the storage chamber includes at least one of a refrigerating chamber and a freezing chamber. The refrigerator further includes a protector configured to prevent the refrigerator from falling down when the moving member moves in the forward and backward directions. The refrigerator further includes a motor configured to provide a driving force to the moving member to move the moving member in response to opening and closing of the door.
- [16] In yet another aspect, a refrigerator includes a cold air generator configured to generate cold air. The refrigerator also includes a storage chamber having a first moving member and a second moving member, configured to receive the cold air generated by the cold air generator, and store at least one food and ice stuffs. The refrigerator further includes a first door configured to open and close at least a part of the storage chamber, wherein the first moving member is configured to be moved in forward and backward directions in response to opening and closing of the first door. In addition, the refrigerator includes a second door configured to open and close at least a part of the storage chamber, wherein the second moving member is configured to be moved in forward and backward directions in response to opening and closing of the second door.
- [17] Implementations may include one or more of the following features. For example, the first moving member includes a first inner frame configured to be slidably moved in the forward and backward directions and a first moving structure positioned in the first inner frame, and configured to be moved together with the first inner frame. The second moving member includes a second inner frame configured to be slidably moved in the forward and backward directions and a second moving structure positioned in the second inner frame, and configured to be moved together with the second inner frame.
- [18] The second moving member is a part of the first moving member. The first door is a refrigerator chamber door and the second door is at least one of a home bar door and a basket door. The first door is a refrigerator chamber door and the second door is a freezing chamber door.
- [19] In some examples, the first and the second door are independently opened and closed. The storage chamber comprises at least one of a refrigerating chamber and a freezing chamber. The refrigerator further includes a third door configured to open and close at least a part of the storage chamber and a third moving member configured to

be moved in forward and backward directions in response to opening and closing of the third door.

Advantageous Effects of Invention

- [20] In this implementation, an end of protector (e.g., a string) is connected to the refrigerator and the other end of the protector is connected to the wall such that the refrigerator can't be moved away from the wall.
- [21] As has been described, since the storage structure mounted in the storage chamber can be movable in front/rear directions, drawing out/pushing in of a storage object becomes more convenient.

Brief Description of Drawings

- [22] FIG. 1 illustrates a view of a refrigerator when a refrigerating chamber and a freezing chamber are opened;
- [23] FIG. 2 illustrates an exploded perspective view of an inner frame, shelves and drawers mounted therein;
- [24] FIG. 3 illustrates a perspective view showing a state in which a refrigerating chamber door and an inner frame are connected with a link device in a door closed state; and
- [25] FIGS. 4 and 5 illustrate perspective views of sliding structures of the inner frames, respectively.

Best Mode for Carrying out the Invention

- [26] Reference will now be made in detail to the specific implementations of the present technology, examples of which are illustrated in the accompanying drawings FIGS. 1 to 5. Wherever possible, the same reference numbers will be used throughout the drawings to refer to the same or like parts.
- [27] A refrigerator shown in FIG. 1 is a side by side door type refrigerator, wherein a freezing chamber 10 is on a left side and a refrigerating chamber 20 is on a right side.
- [28] The refrigerating chamber 20 and the freezing chamber 10 are opened/closed by a refrigerating chamber door 21 and a freezing chamber door 11, respectively. In inside walls of the refrigerating chamber door 21 and the freezing chamber door 11, there are shelves and so on for storage, respectively. And, there are an ice maker mounted to the freezing chamber door 11 and a home bar mounted to the refrigerating chamber door 21.
- [29] Mounted in spaces of the refrigerating chamber 20 and the freezing chamber 10, there are storage structures 30 and 40, respectively. The storage structures 30 and 40 are mounted to be movable in front/rear directions in the refrigerating chamber 20 and the freezing chamber 10.
- [30] Since it is required to secure spaces for placing the ice maker or the home bar therein at the time the refrigerating chamber door 21 and the freezing chamber door 11 are

closing, front/rear direction depths of the storage structures 30 and 40 can be determined, taking the spaces to be secured into account.

[31] Each of the storage spaces 30 and 40 includes an inner frame 43 and a plurality of shelves and drawers arranged vertically in the inner frame 43, as shown in FIG. 2. FIG. 1 illustrates a perspective view showing the storage structures 30 and 40 moved forward.

[32] The storage structure will be described in detail with reference to the storage structure 40 mounted in the refrigerating chamber 20.

[33] Referring to FIG. 2, the inner frame 43 includes one pair of vertical supporting frames 44, a top frame 45 extended from a top edge of the supporting frames 44 perpendicular thereto, and a bottom frame 46 extended from a bottom edge of the supporting frames 44 perpendicular thereto.

[34] There are a plurality of shelves 41 arranged in a vertical direction in the one pair of the supporting frames 44, and a drawer unit 42 having a plurality of drawers provided therein under the shelves 41.

[35] As a variation, a plurality of drawers can be provided and mounted to the inner frame 43, individually.

[36] The inner frame 43 is housed in the refrigerating chamber 20. Though the inner frame 43 has a height as high as the refrigerating chamber 20, as a variation, the inner frame 43 can be fabricated to have a height lower than the refrigerating chamber 20. That is, the inner frame 43 can be fabricated to have a height to occupy a portion of the refrigerating chamber 20 space, such as an upper space thereof or a lower space thereof.

[37] Referring to FIG. 4, the inner frame 43 is mounted to be slidable along wall surfaces of the refrigerating chamber 20 in front/rear directions.

[38] FIGS. 4 and 5 illustrate perspective views each showing the inner frame 43 mounted such that a top surface and a bottom surface of the inner frame 43 are slidable with respect to a ceiling surface and a bottom surface of the refrigerating chamber 20, respectively.

[39] In detail, the refrigerating chamber 20 has a top sliding guide 72 mounted to the ceiling surface thereof and the inner frame 43 has a top slider 71 mounted to the top surface thereof slidably connected to the top sliding guide 72. The top slider 71 and the top frame 45 of the inner frame 43 together form a top sliding unit.

[40] The refrigerating chamber 20 has a bottom slider 82 mounted on a bottom surface, and to match with this, the inner frame 43 has a bottom slider 81 mounted to a bottom surface of the inner frame 43. The bottom slider 81 and the bottom frame 46 together form a bottom sliding unit.

[41] Owing to above sliding structure, the inner frame 43 can slide in the refrigerating

chamber 20 in front/rear directions.

- [42] In the meantime, there are link devices 60 and 65 mounted to the refrigerator for making the inner frame 43 to be movable in front/rear directions interlocked to the opening/closing of the refrigerating chamber door 21.
- [43] The link device includes a first link 61 or 66 rotatably connected to the inner frame 43, and a second link 62 or 67 rotatably connected to the refrigerating chamber door 21.
- [44] The link devices 60 and 65 are mounted to a top and a bottom respectively, wherein the top first link 61 and the top second link 62 are mounted to the top, and the bottom first link 66 and the bottom second link 67 are mounted to the bottom.
- [45] There can be another means for interlocking the opening/closing of the refrigerating door 21 with the sliding of the inner frame 43. For an example, a rack gear can be provided to the inner frame 43, and a motor can be connected to the rack gear through a gear. Accordingly, the motor is made to operate as the door 21 opens, to make the inner frame 43 to slide forward.
- [46] In a state the refrigerating door 21 is closed, the refrigerator has the inner frame 43 positioned on a rear side of the refrigerating chamber 20, and the home bar and the shelves mounted in the inside wall of the refrigerating chamber door 21 positioned in a front side space of the refrigerating chamber 20. FIG. 3 illustrates a perspective view showing arrangement of the inner frame 43 and the refrigerating chamber door 21 in a state the refrigerating chamber door 21 is closed.
- [47] In this state, if the refrigerating chamber door 21 is opened, the inner frame 43 slides forward interlocked with the opening of the refrigerating chamber door 21. FIG. 1 illustrates a perspective view showing a state the inner frame 43 is drawn out to a front side in a state the refrigerating chamber door 21 is opened, fully.
- [48] In some examples, the inner frame is moved in forward and backward directions in connection with opening and closing the refrigerating chamber door 21. In the opening operation, after the refrigerating chamber door 21 is opened to open the refrigerating chamber 20 or while the refrigerating chamber door 21 is being opened, the motor provides a driving force to the rack gear to move the closing motor in the forward or front direction. In the closing state, before the refrigerating chamber door 21 is closed to close the refrigerating chamber 20 or while the refrigerating chamber door 21 is being closed, the motor provides a driving force to the rack gear to move the inner frame in the backward or rear direction.
- [49] In some examples, configuration of the inner frame 43 can be modified. For example, a plurality of the inner frames could be mounted in the refrigerating chamber 20. If the refrigerator has two inner frames, as an example, an upper inner frame may have a height that corresponds to that of the home bar, and a lower inner frame may have a

height that corresponds to that of the baskets location. That is, as shown in FIG 3, the refrigerating chamber door 21 may divide two doors, which are a home bar door 22 and a basket door 23. In this implementation, a user may independently open and close the home bar door 22 and the basket door 23. When the user opens the home bar door 22, the upper inner frame and a corresponded structure (e.g., a plurality of shelves or draws) that is mounted in the upper inner frame move in the forward direction of the refrigerator, and when the user closes the home bar door 22, the upper inner frame and the corresponded structure move in the backward direction of the refrigerator.

Likewise, when the user opens the bracket door 23, the lower inner frame and a corresponded structure that is coupled to the bracket door move in the forward direction of the refrigerator, and when the user closes the bracket door 23, the lower inner frame and the corresponded structure move in the backward direction of the refrigerator.

[50] Further, in the above implementation, when the user opens the refrigerating chamber door 21, the inner frame 43 and the corresponded structure 40 as shown in FIGS. 4 and 5 move in the forward direction of the refrigerator, and when the user closes the refrigerating chamber door 21, the inner frame 43 and the corresponded structure move 40 in the backward direction of the refrigerator. In this case, the home bar door 22 and the basket door 23 may be a part of the refrigerating chamber door 21. Also, moving structure or structure in connection with the home bar door 22 may be a part of the moving structure 40. Further, moving structure in connection with the basket door 23 may be a part of the moving structure 40.

[51] As a moving structure(i.e., a part of storage chamber) may be moved in connection with movement of a door, various modifications are possible. For example, two moving members are moved in connection with opening and closing the refrigerating chamber door 21 and the home bar door 22, respectively. Alternatively, two moving members are moved in connection with opening and closing opening and closing the refrigerating chamber door 21 and the basket door 23, respectively. The moving members may include the inner frame and corresponded structure or components.

[52] As an example, the home bar door 22 is a part of the refrigerating chamber door 21. So, the moving member moved in connection with the home bar door may be a part of the moving member moved in connection with the refrigerating chamber door 21.

[53] It is also available that a plurality of moving members in a refrigerators that are independently moved in connection with opening and closing of three or more than three doors.

[54] Since moving member or members are moved in the forward and backward directions, the refrigerator may need a protector to prevent the refrigerator from falling down. For example, when the moving structure 40 moves in the forward direction of the refrigerator, a lot of stuffs contained in the storage chamber also move in the

forward direction. Therefore, it may cause to fall the refrigerator down because a relatively heavy weight was shifted to the front or forward side within a short period. To avoid falling down, the refrigerator may keep contacting or connecting an adjacent thing, such as a wall, when the moving structure 30 or 40 moves in the forward direction. In this implementation, an end of protector (e.g., a string) is connected to the refrigerator and the other end of the protector is connected to the wall such that the refrigerator can't be moved away from the wall.

[55] As has been described, since the storage structure mounted in the storage chamber can be movable in front/rear directions, drawing out/pushing in of a storage object becomes more convenient.

[56] It will be understood that various modifications may be made without departing from the spirit and scope of the claims. For example, advantageous results still could be achieved if steps of the disclosed techniques were performed in a different order and/or if components in the disclosed systems were combined in a different manner and/or replaced or supplemented by other components. Accordingly, other implementations are within the scope of the following claims.

Claims

- [Claim 1] A refrigerator comprising:
a cold air generator configured to generate cold air;
a storage chamber configured to receive the cold air generated by the cold air generator, and store at least one food and ice stuffs;
a storage chamber door configured to open and close an access point to the storage chamber; and
an inner frame coupled to the storage chamber and configured to move at least a part of the storage chamber in forward and backward directions.
- [Claim 2] The refrigerator of claim 1, further comprising:
a drawing out device configured to move the inner frame in connection with opening and closing of the door.
- [Claim 3] The refrigerator of claim 2, wherein the drawing out device comprises:
a link device connected to the door and the inner frame.
- [Claim 4] The refrigerator of claim 3, wherein the link device comprises:
a first link connected to the inner frame; and
a second link connected to the door.
- [Claim 5] The refrigerator of claims 1, wherein the inner frame comprises:
an upper surface positioned at upper side from a center of the refrigerator and slidably connected to a top wall surface of the storage chamber; and
a lower surface positioned at lower side from the center of the refrigerator and slidably connected to a bottom wall surface of the storage chamber.
- [Claim 6] The refrigerator of claims 5, wherein the inner frame comprises;
a top sliding unit slidably connected to a ceiling surface of the storage chamber; and
a bottom sliding unit slidably connected to a bottom surface of the storage chamber.
- [Claim 7] The refrigerator of claim 1, wherein the at least a part of the storage chamber comprises the plurality of shelves and/or drawers that are mounted in the inner frame.
- [Claim 8] The refrigerator of claim 1, wherein the storage chamber comprises at least one of a refrigerating chamber and a freezing chamber.
- [Claim 9] The refrigerator of claim 1, further comprising:
a protector configured to prevent the refrigerator from falling down

- when the inner frame moves in the forward and backward directions.
- [Claim 10] A refrigerator comprising:
a cold air generator configured to generate cold air;
a storage chamber having a moving member, configured to receive the cold air generated by the cold air generator, and store at least one food and ice stuffs; and
a door configured to open and close the storage chamber, wherein the moving member is configured to be moved in forward and backward directions in response to opening and closing of the door.
- [Claim 11] The refrigerator of claim 10, wherein the moving member comprises:
an inner frame configured to be slidably moved in the forward and backward directions; and
a moving structure mounted in the inner frame, and configured to be moved together with the inner frame.
- [Claim 12] The refrigerator of claim 11, wherein the moving structure comprises at least one a shelf and a drawer.
- [Claim 13] The refrigerator of claim 10, further comprising:
a drawing out device configured to move the moving member responsive to opening and closing of the door.
- [Claim 14] The refrigerator of claim 13, wherein the drawing out device comprise a link device connected to the door and the inner frame.
- [Claim 15] The refrigerator of claim 10, wherein the storage chamber comprises at least one of a refrigerating chamber and a freezing chamber.
- [Claim 16] The refrigerator of claim 10, further comprising:
a protector configured to prevent the refrigerator from falling down when the moving member moves in the forward and backward directions.
- [Claim 17] The refrigerator of claim 10, further comprising:
a motor configured to provide a driving force to the moving member to move the moving member in response to opening and closing of the door.
- [Claim 18] A refrigerator comprising:
a cold air generator configured to generate cold air;
a storage chamber having a first moving member and a second moving member, configured to receive the cold air generated by the cold air generator, and store at least one food and ice stuffs;
a first door configured to open and close at least a part of the storage chamber, wherein the first moving member is configured to be moved

in forward and backward directions in response to opening and closing of the first door; and

a second door configured to open and close at least a part of the storage chamber, wherein the second moving member is configured to be moved in forward and backward directions in response to opening and closing of the second door.

[Claim 19]

The refrigerator of claim 18, wherein the first moving member comprises:

a first inner frame configured to be slidably moved in the forward and backward directions; and

a first moving structure positioned in the first inner frame, and configured to be moved together with the first inner frame.

[Claim 20]

The refrigerator of claim 18, wherein the second moving member comprises:

a second inner frame configured to be slidably moved in the forward and backward directions; and

a second moving structure positioned in the second inner frame, and configured to be moved together with the second inner frame.

[Claim 21]

The refrigerator of claim 18, wherein the second moving member is a part of the first moving member.

[Claim 22]

The refrigerator of claim 18, wherein the first door is a refrigerator chamber door and the second door is at least one of a home bar door and a basket door.

[Claim 23]

The refrigerator of claim 18, wherein the first door is a refrigerator chamber door and the second door is a freezing chamber door.

[Claim 24]

The refrigerator of claim 18, wherein the first and the second door are independently opened and closed.

[Claim 25]

The refrigerator of claim 18, wherein the storage chamber comprises at least one of a refrigerating chamber and a freezing chamber.

[Claim 26]

The refrigerator of claim 18, further comprising:

a third door configured to open and close at least a part of the storage chamber; and

a third moving member configured to be moved in forward and backward directions in response to opening and closing of the third door.

[Fig. 2]

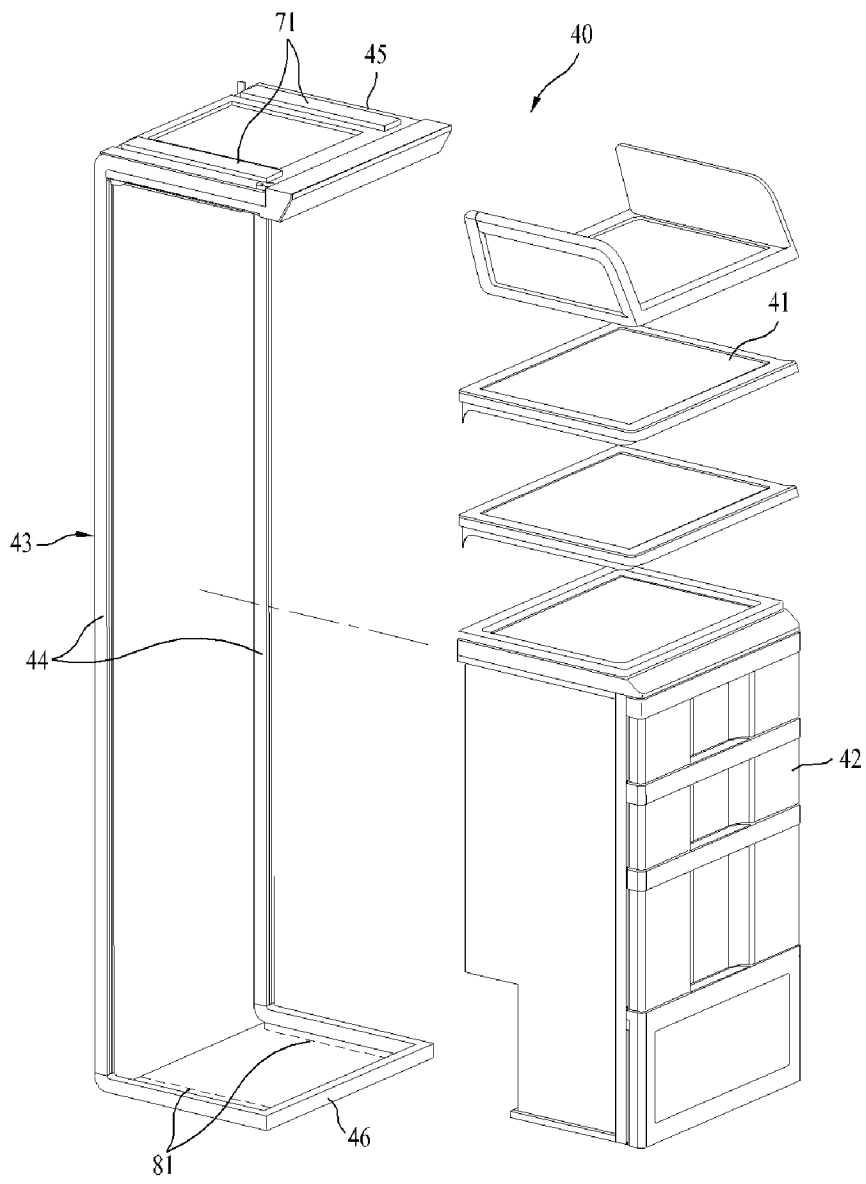

[Fig. 3]

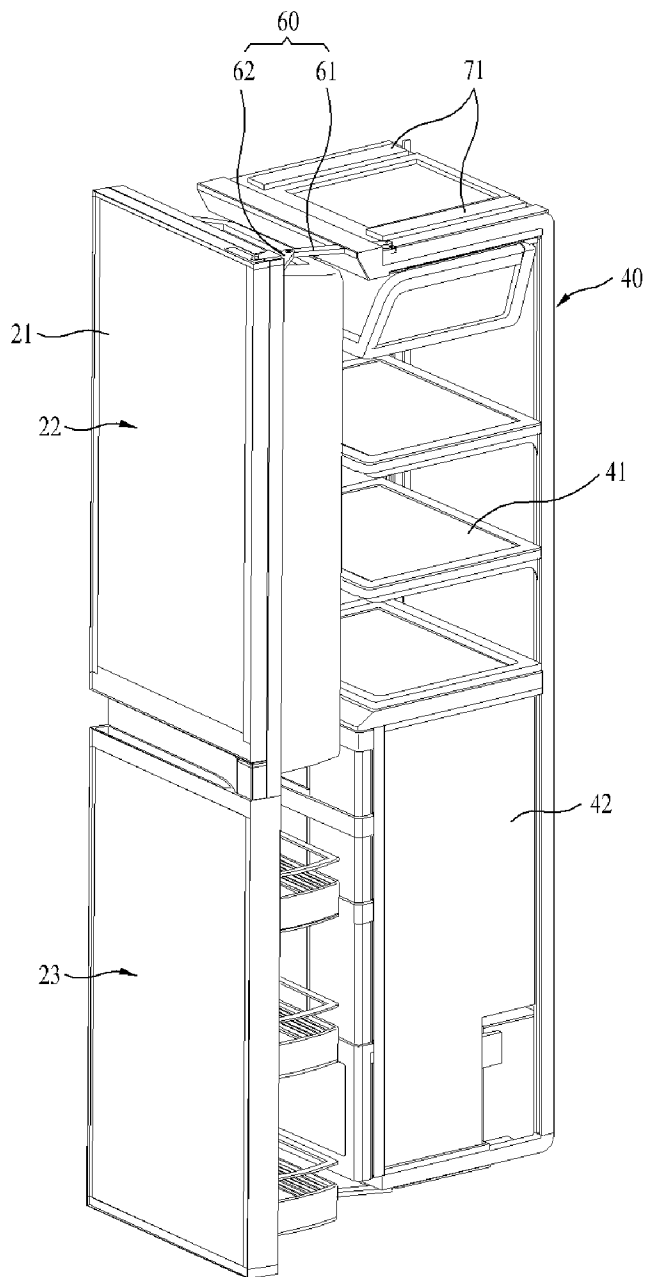

[Fig. 4]

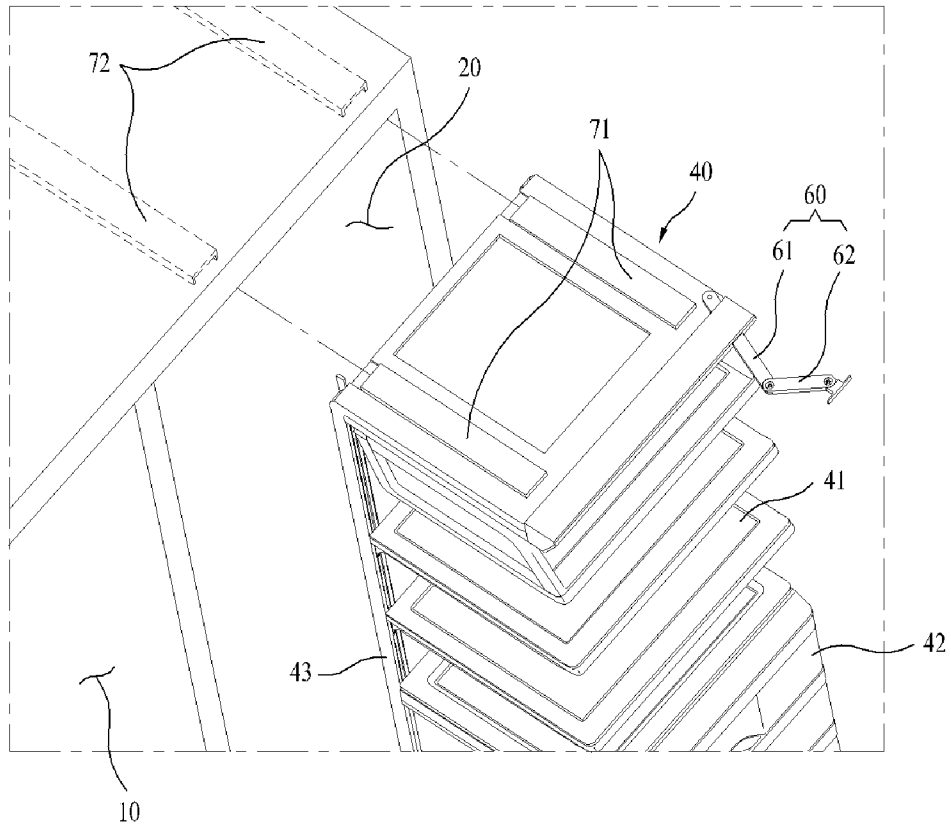

[Fig. 5]

