

(19) World Intellectual Property Organization
International Bureau



(43) International Publication Date
27 September 2001 (27.09.2001)

PCT

(10) International Publication Number
WO 01/70137 A2

- (51) International Patent Classification⁷: **A61F 2/28**
- (21) International Application Number: PCT/US01/09273
- (22) International Filing Date: 22 March 2001 (22.03.2001)
- (25) Filing Language: English
- (26) Publication Language: English
- (30) Priority Data:
60/191,099 22 March 2000 (22.03.2000) US
- (71) Applicant (for CA only): **SYNTHES (U.S.A)** [US/US];
1690 Russell Road, Paoli, PA 19301-1222 (US).
- (71) Applicant (for all designated States except CA, US): **SYN-
THES AG CHUR** [CH/CH]; Grabenstrasse 15, CH-7002
Chur (CH).
- (72) Inventors; and
- (75) Inventors/Applicants (for US only): **BOYER, Michael,
L., II** [US/US]; 1708 East Lancaster Avenue, Paoli, PA
19301 (US). **PAUL, David, C.** [IN/US]; 405 Greene Lane,
Phoenixville, PA 19460 (US). **HIGGINS, Thomas, B.**
[US/US]; 447 Coldstream Drive, Berwyn, PA 19312 (US).
- (74) Agents: **POISSANT, Brian, M.** et al.; Pennie & Edmonds
LLP, 1155 Avenue of the Americas, New York, NY 10036
(US).
- (81) Designated States (national): AE, AG, AL, AM, AT, AU,
AZ, BA, BB, BG, BR, BY, BZ, CA, CH, CN, CO, CR, CU,
CZ, DE, DK, DM, DZ, EE, ES, FI, GB, GD, GE, GH, GM,
HR, HU, ID, IL, IN, IS, JP, KE, KG, KP, KR, KZ, LC, LK,
LR, LS, LT, LU, LV, MA, MD, MG, MK, MN, MW, MX,
MZ, NO, NZ, PL, PT, RO, RU, SD, SE, SG, SI, SK, SL,
TJ, TM, TR, TT, TZ, UA, UG, US, UZ, VN, YU, ZA, ZW.

[Continued on next page]

(54) Title: MULTIPIECE IMPLANTS FORMED OF BONE MATERIAL

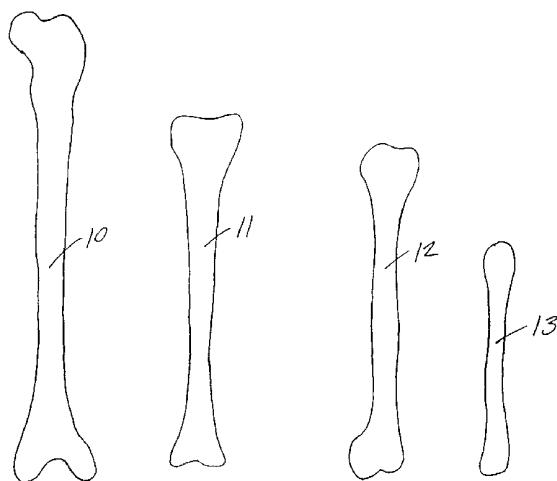

(57) Abstract: The present invention relates to an implant comprising two or more bone fragments that are combined to form a single unit. Cancellous bone or cortical bone is removed from a source and fashioned into bone components with desirable shapes and sizes. The bone components may be integrated to form implants for implantation in the body. Bone stock may be formed by combining sections of various bones of the body, and the bone stock may be further fashioned for use as implants with particular geometries.

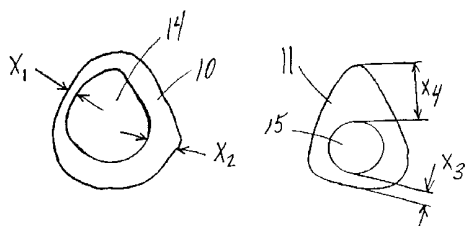

WO 01/70137 A2



(84) Designated States (regional): ARIPO patent (GH, GM, KE, LS, MW, MZ, SD, SL, SZ, TZ, UG, ZW), Eurasian patent (AM, AZ, BY, KG, KZ, MD, RU, TJ, TM), European patent (AT, BE, CH, CY, DE, DK, ES, FI, FR, GB, GR, IE, IT, LU, MC, NL, PT, SE, TR), OAPI patent (BF, BJ, CF, CG, CI, CM, GA, GN, GW, ML, MR, NE, SN, TD, TG).

Published:

— *without international search report and to be republished upon receipt of that report*

For two-letter codes and other abbreviations, refer to the "Guidance Notes on Codes and Abbreviations" appearing at the beginning of each regular issue of the PCT Gazette.

MULTIPIECE IMPLANTS
FORMED OF BONE MATERIAL

5

FIELD OF THE INVENTION

10 The invention relates to an implant for orthopedic applications. More particularly, the invention is related to an implant formed from two or more bone portions.

BACKGROUND OF THE INVENTION

 Bone grafts have become an important and accepted means for treating bone
15 fractures and defects. In the United States alone, approximately half a million bone grafting procedures are performed annually, directed to a diverse array of medical interventions for complications such as fractures involving bone loss, injuries or other conditions necessitating immobilization by fusion (such as for the spine or joints), and other bone defects that may be present due to trauma, infection, or disease. Bone grafting involves the
20 surgical transplantation of pieces of bone within the body, and generally is effectuated through the use of graft material acquired from a human source. This is primarily due to the limited applicability of xenografts, transplants from another species.

 Orthopedic autografts or autogenous grafts involve source bone acquired from the same individual that will receive the transplantation. Thus, this type of transplant
25 moves bony material from one location in a body to another location in the same body, and has the advantage of producing minimal immunological complications. It is not always possible or even desirable to use an autograft. The acquisition of bone material from the body of a patient typically requires a separate operation from the implantation procedure. Furthermore, the removal of material, oftentimes involving the use of healthy material from
30 the pelvic area or ribs, has the tendency to result in additional patient discomfort during rehabilitation, particularly at the location of the material removal. Grafts formed from synthetic material have also been developed, but the difficulty in mimicking the properties of bone limits the efficacy of these implants.

 As a result of the challenges posed by autografts and synthetic grafts, many
35 orthopedic procedures alternatively involve the use of allografts, which are bone grafts from other human sources (normally cadavers). The bone grafts, for example, are placed in a host

bone and serve as the substructure for supporting new bone tissue growth from the host bone. The grafts are sculpted to assume a shape that is appropriate for insertion at the fracture or defect area, and often require fixation to that area as by screws or pins. Due to the availability of allograft source material, and the widespread acceptance of this material
5 in the medical community, the use of allograft tissues is certain to expand in the field of musculoskeletal surgery.

FIGS. 1A, 1B, 1C, and 1D show the relative sizes of the femur 10 (thigh), tibia 11 (lower leg), humerus 12 (upper arm), and radius 13 (lower arm) respectively for an adult. As can be seen when comparing these bones, their geometry varies considerably.
10 The lengths of these bones may have a range, for example, from 47 centimeters (femur), to 26 centimeters (radius). In addition, as shown in FIGS. 1E and 1F, the shape of the cross section of each type of bone varies considerably, as does the shape of any given bone over its length. While the femur 10, as shown in FIG. 1E, has a generally rounded outer shape, the tibia 11 has a generally triangular outer shape as shown in FIG. 1F. The wall thickness
15 also varies in different areas of the cross-section of each bone. For example, femur 10 has a wall thickness X_1 that is much smaller than wall thickness X_2 . Similarly, tibia 11 has a wall thickness X_3 that is much smaller than wall thickness X_4 . Even after clearing the inner canal regions 14 and 15 within the bones, the contours of these canals vary considerably. Thus, machining of the bone to have standardized outer dimensions and/or canal dimensions is
20 necessary in many applications.

Sections of bones with regions having narrow cross-sections, as seen for example with thicknesses X_1 and X_3 , may be rejected for use in certain applications because the wall thickness does not have sufficient strength. Preferably, no region of a bone section has a thickness less than 5 millimeters, although in some applications smaller wall
25 thicknesses may be employed. Thus, in the case that a bone section is found to have a region with a wall thickness less than a minimum acceptable thickness, such a bone section is rejected as being unsuitable for use in a bulk configuration. Often, such a section is ground into bone particulate that is then used in other applications. The minimum thickness standards imposed on the use of bone sections results in the rejection of substantial
30 quantities of bone sections, and thus an inefficient use of the material. Bone sections that do not meet the minimum thickness standards are often found in older individuals.

As a collagen-rich and mineralized tissue, bone is composed of about forty percent organic material (mainly collagen), with the remainder being inorganic material (mainly a near-hydroxyapatite composition resembling $3\text{Ca}_3(\text{PO}_4)_2 \cdot \text{Ca}(\text{OH})_2$). Structurally,
35 the collagen assumes a fibril formation, with hydroxyapatite crystals disposed along the length of the fibril, and the individual fibrils are disposed parallel to each other forming

fibers. Depending on the type of bone, the fibrils are either interwoven, or arranged in lamellae that are disposed perpendicular to each other.

There is little doubt that bone tissues have a complex design, and there are substantial variations in the properties of bone tissues with respect to the type of bone (*i.e.*,
5 leg, arm, vertebra) as well as the overall structure of each type. For example, when tested in the longitudinal direction, leg and arm bones have a modulus of elasticity of about 17 to 19 GPa, while vertebra tissue has a modulus of elasticity of less than 1 GPa. The tensile strength of leg and arm bones varies between about 120 MPa and about 150 MPa, while vertebra have a tensile strength of less than 4 MPa. Notably, the compressive strength of
10 bone varies, with the femur and humerus each having a maximum compressive strength of about 167 MPa and 132 MPa respectively. Again, the vertebra have a far lower compressive strength of no more than about 10 MPa.

With respect to the overall structure of a given bone, the mechanical properties vary throughout the bone. For example, a long bone (leg bone) such as the femur
15 has both compact bone and spongy bone. Cortical bone, the compact and dense bone that surrounds the marrow cavity, is generally solid and thus carries the majority of the load in major bones. Cancellous bone, the spongy inner bone, is generally porous and ductile, and when compared to cortical bone is only about one-third to one-quarter as dense, one-tenth to one-twentieth as stiff, but five times as ductile. While cancellous bone has a tensile strength
20 of about 10-20 MPa and a density of about 0.7, cortical bone has a tensile strength of about 100-200 MPa and a density of about 2. Additionally, the strain to failure of cancellous bone is about 5-7%, while cortical bone can only withstand 1-3% strain before failure. It should also be noted that these mechanical characteristics may degrade as a result of numerous factors such as any chemical treatment applied to the bone material, and the manner of
25 storage after removal but prior to implantation (*i.e.* drying of the bone).

Notably, implants of cancellous bone incorporate more readily with the surrounding host bone, due to the superior osteoconductive nature of cancellous bone as compared to cortical bone. Furthermore, cancellous bone from different regions of the body is known to have a range of porosities. Thus, the design of an implant using cancellous
30 bone may be tailored to specifically incorporate material of a desired porosity.

It is essential to recognize the distinctions in the types and properties of bones when considering the design of implants. Surgeons often work with bones using similar tools as would be found in carpentry, adapted for use in the operating room environment. This suggests that bones have some properties which are similar to some
35 types of wood, for example ease in sawing and drilling. Notably, however, are many differences from wood such as the abrasive nature of hydroxyapatite and the poor response

to local heating during machining of a bone. The combination of tensile and compressive strengths found in bone, resulting from the properties of the collagen and hydroxyapatite, is thus more aptly compared to the tensile and compressive strengths found in reinforced concrete, due to steel and cement. Furthermore, while wood is readily available in
5 considerable quantity, bone material is an extremely limited resource that must be used in an extremely efficient manner.

Various types of bone grafts are known. For example, as disclosed in U.S. Patent No. 5,989,289 to Coates et al., a spinal spacer includes a body formed of a bone composition such as cortical bone. The spacer has walls that define a chamber that is sized
10 to receive an osteogenic composition to facilitate bone growth.

U.S. Patent No. 5,899,939 to Boyce et al. discloses a bone-derived implant for load-supporting applications. The implant has one or more layers of fully mineralized or partially demineralized cortical bone and, optionally, one or more layers of some other material. The layers constituting the implant are assembled into a unitary structure, as by
15 joining layers to each other in edge-to-edge fashion in a manner analogous to planking.

Another bone-grafting material is disclosed in U.S. Patent No. 4,678,470 to Nashef *et al.*, and is formed using a tanning procedure involving glutaraldehyde that renders the material osteoinvasive. A bone block is shaped into a precise predetermined form and size using conventional machining techniques. A paste-like suspension is also formed using
20 known methods of comminuting bone, such as milling, grinding, and pulverizing, and adding the pulverized or powdered bone to a carrier. The treatment with glutaraldehyde allows the use of bovine, ovine, equine, and porcine bone sources. However, if the final desired form of the bone grafting material is a block of bone or machined shape, the bone stock must be large enough to provide a block of the required size.

U.S. Patent No. 5,981,828 to Nelson *et al.* discloses a "composite" acetabular allograft cup for use in hip replacement surgery. A press is used to form the cup from impacted cancellous bone chips and cement. The composite is a hollow hemispherical dome having an outer surface comprised essentially of exposed cancellous bone chips and an inner surface comprised essentially of hardened bone cement. The cancellous bone chips are first
30 placed in a mold and subjected to a load to form a compact and consolidated mass that conforms to the shape of the mold. The mold is then opened, cement is applied, and the mold is then reapplied. While an allograft of a particular shape may be formed using this process, the process is limited to forming an allograft by compressing cancellous bone chips. Thus, numerous molds are required in order to produce allografts of different sizes, and the
35 use of bulk-size allograft source material is not facilitated.

With a rapidly increasing demand in the medical profession for devices incorporating bone material, the tremendous need for the tissue material itself, particularly allograft tissue material, presents a considerable challenge to the industry that supplies the material. Due to the size and shape of the bones from which the material is harvested, and the dimensional limitations of any particular type of bone in terms of naturally occurring length and thickness (*i.e.* cortical or cancellous), there is a need for a means by which individual bone fragments can be combined to form larger, integral implants that are more suitable for use in areas of larger fractures or defects. For example, the size of cortical bone fragments needed to repair a fracture or defect site is often not available in a thick enough form. While multiple fragments may together meet the size and shape requirements, several prominent concerns have placed a practical limitation on the implementation of this concept. There is considerable uncertainty regarding the structural integrity provided by fragments positioned adjacent to one another without bonding or other means of securing the fragments to each other. Moreover, there is concern over the possibility that a fragment may slip out of position, resulting in migration of the fragment and possible further damage in or near the area of implantation.

In addition, due to the geometry of bones such as the femur and tibia, all portions of the bones are not readily usable as a result of size limitations. Thus, prior art implants, specifically allografts, are produced with an inefficient use of source bones.

There is a need for new, fundamental approaches to working with and processing tissues, in particular allograft material, especially with regard to machining, mating, and assembling bone fragments. Specifically, there is a need for an implant that allows more efficient use of source material. More specifically, there is a need for an implant that is an integrated implant comprising two or more bone fragments that are interlocked to form a mechanically effective, strong unit.

SUMMARY OF THE INVENTION

The present invention is related to an implant including a body having an inner sheath and at least one outer sheath. Each sheath is formed from a different bone and has an interior surface and an exterior surface. The exterior surface of each outer sheath contacts the interior surface of no more than one other outer sheath. In one embodiment, a core is disposed in the inner sheath and is formed from a bone other than the bones of the sheaths. The core can be formed of cancellous bone, while at least one sheath can be formed of cortical bone. In another embodiment, at least one sheath can be formed of cancellous bone and the core can be formed of cortical bone. The bones are at least one of autograft, allograft, and xenograft bone tissue, and the bone tissue of at least one bone may be partially

demineralized or demineralized. In a further embodiment, the body is formed from a cross-section of the sheaths and core, with the cross-section including at least a portion of each sheath and core. The sheaths and core can be coupled together with at least one fastener that may intersect each of the sheaths and core, with the fastener being a screw, key, pin, peg, rivet, cotter, nail, spike, bolt, stud, staple, boss, clamp, clip, dowel, stake, hook, anchor, tie, band, crimp, or wedge. Also, the sheaths and core can be bonded together with a bonding agent. At least one sheath may be packed with bone growth materials and may include alignment indicia. The exterior surface may be separated from a portion of the interior surface.

10 At least one of the inner sheath, an outer sheath, and the core can be at least partially dehydrated to fit against a surrounding mating surface. Furthermore, at least one of the inner sheath, an outer sheath, and the core can be at least partially dehydrated to fit within a surrounding inner sheath or outer sheath provided with a greater moisture content.

Contacting surfaces of adjacent sheaths can be machined surfaces so that the contour of the contacting surfaces is about the same. The machined surfaces permit press-fitting of one sheath into another sheath. In some embodiments, the bones are selected from a femur, tibia, humerus, fibula, ulna, and radius.

At least one supplemental sheath having an interior surface and an exterior surface also may be included, with the exterior surface of each supplemental sheath contacting the interior surface of no more than one other sheath and the interior surface of each supplemental sheath contacting the exterior surface of no more than one other sheath. The at least one supplemental sheath is formed of a material selected from metals, alloys, ceramics, polymers, and composites.

The present invention is also related to an implant having a body formed from a cross-section of a core and a plurality of sheaths. Each sheath has an inner surface and an outer surface, and at least two sheaths are formed from different bones. The outer surface of a first sheath has about the same contour as the inner surface of a second sheath so that the first and second sheaths mate together, and the cross-section includes at least a portion of each sheath and core. The core may be formed from a bone other than the bones of the sheaths, and in one embodiment the core is formed of cancellous bone and at least one sheath is formed of cortical bone. In another embodiment, at least one sheath is formed of cancellous bone and the core is formed of cortical bone.

Also, the present invention is related to an implant with a body that includes at least one sheath defining a hole, with a core fit therein. The body is formed from at least two different bones selected from a femur, tibia, humerus, fibula, ulna, and radius.

Furthermore, the present invention is related to an implant with a body having two outer annular members and at least one inner annular member. At least one of the annular members is formed from bone and the annular members are coupled together to create a central chamber. In one embodiment, each annular member has at least one surface that is press-fit with the surface of another annular member. The outside diameter of the outer annular members may be smaller than the outside diameter of the at least one inner annular member. The implant can be symmetrical about an innermost annular member, with the diameter of the implant progressively decreasing from the innermost annular member to each outer annular member. The central chamber can be packed with at least one of bone material and bone inducing substances.

In one embodiment, at least one annular member is formed of cancellous bone and at least one annular member is formed of cortical bone. A plurality of annular members may be coupled together with at least one fastener. Also, a plurality of annular members may be bonded together with a bonding agent. In some embodiments, the annular members have non-circular shapes, such as generally oblong shapes. At least one supplemental annular member may be coupled to at least one of the annular members formed from bone, with the at least one supplemental annular member being formed of a material selected from metals, alloys, ceramics, polymers, and composites. At least one annular member may include alignment indicia, and adjacent surfaces of at least two annular members may not completely contact each other.

The invention further relates to an implant with a body having at least two ring-shaped members formed from bone that are coupled together to create a central chamber. The ring-shaped members may have ridges that mate and press-fit together.

Another implant of the present invention includes at least two layers of bone components coupled to each other, the components together defining at least one securing region, and at least one insertable securing element adapted for placement in the at least one securing region. The at least one securing region may be a recess or hole, and each layer may be formed from a different bone selected from a femur, tibia, humerus, fibula, ulna, and radius. At least one layer may be formed of cancellous bone and at least one layer may be formed of cortical bone. Also, the layers may include at least one of autograft, allograft, and xenograft bone tissue, and the layers may be bonded together with a bonding agent. The bone tissue of at least one bone may be partially demineralized or demineralized, and the layers may be bonded together with a bonding agent. A first layer may be at least partially dehydrated to mate against at least one other layer. Adjacent layers may be provided with mutually contacting surfaces that are machined to have about the same contour, and the contacting surfaces of adjacent layers may be press-fit together.

In addition, the implant may further include at least one supplemental layer coupled to at least one of the layers of bone components, with the at least one supplemental layer being formed of a material selected from metals, alloys, ceramics, polymers, and composites. Also, the implant may further include a chamber packed with bone growth materials. In some embodiments, at least one layer includes alignment indicia, and the outer surface may be separated from a portion of the inner surface.

The present invention is further related to a hollow body having a minimum wall thickness, the body being formed from a plurality of portions of bone sections with each section having a thick-walled portion and a thin-walled portion. The thick-walled portion has a wall thickness at least as thick as the minimum wall thickness, and the thin-walled section has a wall thickness less than the minimum wall thickness. Only thick-walled portions are coupled together to form the body. The thick-walled portions are coupled together with at least one portion having a first coupling and at least one portion having a second coupling, with the portions being joined together by interfitting together the first and second couplings. At least one coupling may be at least partially dehydrated to mate against another coupling. In one embodiment, the first coupling is a male coupling and the second coupling is a female coupling so that the portions are mated in a male-female relationship. The male coupling may be a tenon and the female coupling may be a mortise, or the male coupling may be a tongue and the female coupling may be a groove.

The present invention is also related to an implant including a layer formed of a first bone and at least one layer formed by a curable carrier, with the at least one layer being molded to the first bone. The layer formed of a first bone may include a primary sleeve with a top surface, a bottom surface, an inner surface, and an outer surface, with the at least one layer of curable carrier being molded to the inner surface or the outer surface. In one embodiment, the curable carrier further includes bone or ceramic in powder, chips, or fibers. At least one secondary sleeve may be provided, with each secondary sleeve being coupled to a primary sleeve or another secondary sleeve by a layer of curable carrier.

Additionally, the present invention is related to a method of forming an implant including: surrounding at least a portion of a bone section with a first mold to create a cavity therebetween; filling the cavity with a first substance, and coupling the first substance to the bone section. The first substance may be at least one of a curable carrier, bone powder, bone chips bone fibers, or ceramic, and be coupled to the bone section by curing or by compaction.

BRIEF DESCRIPTION OF THE DRAWINGS

Preferred features of the present invention are disclosed in the accompanying drawings, wherein similar reference characters denote similar elements throughout the several views, and wherein:

5 FIGS. 1A to 1D show prior art exemplar bone sizes and shapes for bones from an adult human;

 FIGS. 1E-1F show prior art exemplar bone sections having varying wall thickness, the sections taken transverse to the longitudinal axis of the bones;

10 FIGS. 1G to 1I show perspective views of bone portions that may be combined to form an embodiment of an implant of the present development;

 FIGS. 1J to 1K show perspective views of another embodiment of the present development combining multiple bone sections;

 FIG. 2A shows a perspective view of the embodiment of FIG. 1K with section lines;

15 FIG. 2B shows a perspective view of the section of the embodiment of FIG. 1K forming an implant;

 FIG. 2C shows a side view of the implant of FIG. 2B;

 FIG. 2D shows an exploded view of the implant of FIG. 2B;

20 FIGS. 3A to 3C show perspective views of sections of a tibia and femur combined in another embodiment of the present invention;

 FIG. 3D shows a top view of the embodiment of FIG. 3C;

 FIGS. 4A to 4D show top views of yet another embodiment of the present invention combining sections of bone having acceptable wall thickness with mating joints;

25 FIGS. 4E to 4G show exploded, perspective views of another embodiment of the present invention combining sections of bone having acceptable wall thickness with mating joints;

 FIGS. 5A to 5E show perspective views of additional embodiments of the present invention combining multiple bone sections;

30 FIG. 5F shows an exploded, perspective view of another embodiment of the present invention combining multiple bone sections;

 FIG. 6A shows a top view of another embodiment of the present invention forming a femoral ring implant;

 FIG. 6B shows a side view of the implant of FIG. 6A;

35 FIG. 6C shows a cross-section of the implant of FIG. 6A taken along line VIC-VIC;

FIG. 6D shows a cross-section of the implant of FIG. 6A taken along line VID-VID;

FIG. 7A shows perspective views of concentric rings formed of bone material for coupling to form an implant;

5 FIG. 7B shows a side view of an embodiment of the present invention with an implant formed from the concentric rings of FIG. 7A;

FIG. 7C shows an exploded, perspective view of the implant of FIG. 7B;

FIGS. 8A and 8B show exploded, side views of another embodiment of the present invention forming a spacer;

10 FIGS. 8C and 8D show additional side views, respectively, of bone pieces of the spacer of FIGS. 8A and 8B;

FIG. 8E shows a side view of the teeth used in the spacer of FIGS. 8A and 8B;

15 FIGS. 9A to 9C show exploded, perspective views of additional embodiments of the present invention using washer-shaped bone portions;

FIG. 10 shows a top view of an additional embodiment of an implant according to the present invention with bowed bone portions;

FIG. 11 shows a perspective view of an additional embodiment of an implant according to the present invention with press fitting of bone portions in two locations;

20 FIG. 12 shows an exploded, perspective view of an additional embodiment of an implant according to the present invention with bone portions that mate;

FIG. 13 shows a top view of an additional embodiment of a multilayer implant according to the present invention;

FIG. 14 shows an exploded, perspective view of the implant of FIG. 13;

25 FIG. 15 shows a perspective view of an embodiment of the present invention formed with a cancellous body and cortical struts;

FIG. 16 shows an exploded, perspective view of an additional embodiment of the present invention formed with a cancellous body and cortical struts;

30 FIG. 17 shows an exploded, perspective view of an additional embodiment of the present invention formed with a combination of cancellous and cortical bone;

FIG. 18 shows a perspective view of an additional embodiment of the present invention formed with a combination of cancellous and cortical bone; and

FIGS. 19A and 19B show perspective views of the formation of a composite implant by molding.

35

DETAILED DESCRIPTION OF THE PREFERRED EMBODIMENTS

Any of a wide variety of different implant structures, particularly allograft, autograft, and/or xenograft implant structures, can be prepared according to the teachings of the present invention. While a representative selection of implant structures are described and depicted herein, additional disclosure is found in U.S. Provisional Application No. 5 60/191,099 filed March 22, 2000, which is hereby incorporated herein in its entirety by reference, including all figures.

The present invention allows a more efficient use of bone sections, by permitting those sections that would otherwise have been rejected due to insufficient wall 10 thickness to instead be incorporated in a composite bone section. The composite implant is created by taking two or more bone sections and combining them to create a greater wall thickness. Some or all of the natural shape of each bone may be retained. Furthermore, the composite may be formed of a shape appropriate for implantation, or instead may be formed of a shape that is suitable as bone stock for eventual fashioning into a particular implant or 15 forms.

As used in the description of the present invention, the words fitting, interfitting, mating, locking, interlocking, meshing, and interlacing are all used generically to describe the joining of bone sections or pieces together. Thus, these words are not limited to the use of any particular manner of joining. Thus, for example, the press-fitting of one 20 bone section within a cavity formed in another bone section may be described using any of the above-mentioned terms. In addition, although various preferred mechanical fastening approaches are described, the present invention allows the use of any mechanical device for joining two or more separate parts of an article or structure. Such mechanical devices include, but are not limited to the following: screws, keys, pins, pegs, rivets, cotters, nails, 25 spikes, bolts, studs, staples, bosses, clamps, clips, dowels, stakes, hooks, anchors, ties, bands, and crimps. Also, bonding agents or other chemical means for joining two separate parts may be employed alone or in combination with the mechanical devices. Thus, as appropriate, the means disclosed herein for fixing bone sections to each other may be substituted, as with the above-mentioned mechanical devices, bonding devices, or chemical 30 means. Furthermore, although particular types of joints are disclosed, the present invention is directed to the creation of implants that may be joined using other joints.

While the present invention is preferably directed to the creation of implants from allograft material, the present invention may also be applied to implants that utilize other materials, including but not limited to the following: xenograft, autograft, metals, 35 alloys, ceramics, polymers, composites, and encapsulated fluids or gels. Furthermore, the implants described herein may be formed of materials with varying levels of porosity, such

as by combined bone sections from different bones or different types of tissue having varying levels of porosity. For example, cancellous bone is available in a range of porosities based on the location in the body from which the bone is harvested. Extremely porous cancellous bone may be harvested from various areas such as the iliac crest, while less
5 porous bone may be harvested from areas such as a tibial condyle. Thus, the materials properties - particularly the porosity - of the bone components may be selected to meet the needs of a given application.

Cancellous bone components may be attached to syringes or aspirators, and blood or other fluids such as bone-growth inducing substances may be drawn into the plugs.
10 The use of mechanically applied pressure, such as with aspiration devices, permits a greater degree of fluid absorption and/or concentration to be achieved than otherwise readily obtainable by soaking bone in such fluids without applying pressure from a device. In embodiments of the present invention that include hollow regions, a plug of cancellous bone formed using the aforementioned technique may be inserted therein. Alternatively, the
15 plugs may be soaked in a suitable fluid.

Also, the implants described herein may be formed of bone materials with varying mineral content. For example, cancellous or cortical bone may be provided in natural, partially demineralized, or demineralized states. Demineralization is typically achieved with a variety of chemical processing techniques, including the use of an acid such
20 as hydrochloric acid, chelating agents, electrolysis or other treatments. The demineralization treatment removes the minerals contained in the natural bone, leaving collagen fibers with bone growth factors including bone morphogenic protein (BMP). Variation in the mechanical properties of bone sections is obtainable through demineralization. Advantageously, use of a demineralizing agent on natural bone
25 transforms the properties of the bone from a stiff structure to a relatively pliable structure when it is hydrated. Some portions of interfitting bone components may be demineralized in order to achieve improved interfitting. For example, a tissue form may include two bone components having portions that are coupled together with an interference fit. The interference fit may be enhanced if the surface region of one or more of the components is
30 demineralized so that it is pliable and exhibits some elasticity and/or malleability.

In addition, while many of the embodiments described herein show bone components disposed at right angles, or joints formed with right angles, angles that are greater or less than ninety degrees may alternatively be used in implants of the present development.

35 FIG. 1G shows a first embodiment of implant 16 having an outer sheath 17, an intermediary sheath 18, and a core 19. It should be noted that while bone sections

described herein are referred to as sleeves, these components need not be cylindrical or otherwise symmetrical. In this embodiment, outer sheath 17 is a bone section, for example of a femur, that has the outer surface or contour naturally found on a femur. Thus, the outer surface 20 of outer sheath 17 does not require machining and is not machined. The inner
5 surface 21 of outer sheath 17 has been machined to a particular configuration so that intermediary sheath 18 fits within outer sheath 17. Alternatively, as shown in FIG. 1H, implant 16 may have a through hole 22 instead of a core 19, creating a cavity in implant 16. If a through-hole is provided instead of core 19, a hollow implant may be created and bone growth materials such as bone materials in the form of chips, slurries, or fibers, as well as
10 bone inducing substances can be provided therein. While the cavity may be formed from sleeves with two open free ends, such a hollow region may also be created by incorporating one or more sleeves with one free end closed. It should be noted that two or more sections of bone are used to create the composite, and thus there is no limit to the number of sheaths or bone sections that may be combined. Typically, insert or core 19 is cylindrical in shape,
15 as shown in FIG. 1I, and may be made of cancellous bone while each surrounding sheath may be made of cortical bone. Alternating layers of cortical and cancellous bone may be used, or several layers of the same type of bone may be used along with a different type of bone.

The components that are used to create implant 16 may all be formed from
20 cortical bone, all from cancellous bone, or a combination of components formed from cortical and cancellous bone. The interfitting of the components may be achieved through a variety of means, including but not limited to the following: pinning, bonding with a suitable bone bonding agent or chemical means, press fitting, threadably engaging (as by helically screwing one component into another), inserting a tapered component into a
25 component with a matching inner surface, twist-locking, or other interlocking means such as will be described in other embodiments. While the present development preferably allows the creation of an implant 16 from all bone material, it is also anticipated that one or more components used to create implant 16 may be formed of non-bone material such as a synthetic or other material.

30 As shown in FIG. 1J, in a second embodiment of the present invention many types of bones may be combined in layers to form bone stock 25'. A radius 13 may be encased in humerus sleeve 12, which may be encased in tibia sleeve 11, which may further be encased in femur sleeve 10 that retains the original outer shape of the femur. In alternate embodiments, other bones may be used, such as a fibula or ulna. By machining the inner
35 and/or outer surfaces of each bone section, the bone sections may be inserted into each other

with an interfitting relationship. This may result in a strong press-fit, but additional or alternate means of fixation may be employed, such as mechanical means.

The moisture content of the bone sections also may be varied to advantageously permit improved interlocking. Bone sections initially may be provided with
5 moisture content as follows: (1) bone in the natural state fresh out of the donor without freezing, (2) bone in the frozen state, typically at -40°C , with moisture content intact, (3) bone with moisture removed such as freeze-dried bone, and (4) bone in the hydrated state, such as when submersed in water. The expansion and contraction properties that can be obtained from bone during heating, cooling, dehydrating, and hydrating permit an alternate
10 approach to achieving a tight press-fit. In addition, the use of such approaches can provide a tighter press-fit than otherwise obtainable, as well as loosen the manufacturing tolerances required for mating sections of bone.

For example, in the embodiment shown in FIG. 1J, sleeve 12 is initially supplied with a first outer diameter and a first inner diameter. Subsequent freeze-drying of
15 sleeve 12 results in shrinkage such that sleeve 12 assumes a configuration with a second outer diameter that is smaller than the first outer diameter, while having a second inner diameter that is smaller than the first inner diameter. When sleeve 12 is rehydrated or treated with a swelling agent, sleeve 12 may reassume a configuration with the first outer diameter and first inner diameter. By providing a bone section such as a sleeve 12 in the
20 freeze-dried state while disposed inside another bone section such as sleeve 11 that may be loosely interference fit, rehydration of sleeve 12 in place permits a tighter interference fit to be achieved. Notably, a bone section such as core 13 has no inner diameter, and thus such a bone section may shrink in outer diameter only when freeze-dried. Thus, similarly, core 13 may be the bone section that is rehydrated to provide a tighter mating and interference fit
25 with a sleeve 12. Use of these properties can permit greater variation in dimensional tolerance between bone sections during manufacture, while tight final assembly can still be achieved. In addition, protrusions on bone sections become smaller when dehydrated, but expand when rehydrated; in contrast, recesses in bone sections become smaller when hydrated, but larger when dehydrated. Temperature changes may also be used to achieve
30 better interference fits.

Turning to FIGS. 1J-K, a hole 23 of similar dimension may be created in each bone section, and when the holes are aligned to be coaxial, a pin 24 may be inserted in the holes 23 for fixation. Alternatively, the bone sections may have a slot formed therethrough, similar in orientation to pin 24, and a key can be inserted or press-fitted into
35 the slot to fix the sections with respect to each other. Other bones may also be used, for example an ulna (lower arm) is similar in configuration to radius 13, and thus may be

readily substituted. In addition, a fibula can also be readily used in some embodiments, accounting for the size of the bone and any required machining. Also, although the embodiment shown in FIGS. 1J and 1K show bones with generally cylindrical shapes, other shapes can be used, for example by machining the bones to have a rectangular shape or any
5 other shape.

Bone stock 25' is preferably solid, and formed by fitting a smaller diameter bone core within at least one larger diameter sheath. Thus, the availability of precisely machined cores and sheaths permits bone stock 25' to be sized according to the application or anatomy encountered in any given situation. In addition, implants may be constructed
10 from a supply of standardized core and sheath sizes or bone stock sizes so that any required wall thickness can be obtained. The ability to create composite implants of varying sizes has widespread use, particularly in applications such as femoral ring allografts which can benefit from increased wall thicknesses.

In alternate embodiments of bone stock 25', components having non-circular
15 shape may be provided, although not necessarily the natural shape of the original bone. For example, an outer sheath can mate with an inner sheath which has a generally triangular shape, with the inside surface of the outer sheath geometrically conforming to the outside surface of inner sheath. Other polygonal shapes are also contemplated, including parallelograms such as rectangles. In addition, a core may be provided with a shape distinct
20 from both the cylindrical outside surface of the outer sheath and the outside surface of the inner sheath. Thus, the present development permits components with varying outside surface shapes to be interfit to create an implant.

The availability of larger bone stock, as by combining several bone sections, makes it possible to create implants that are properly configured for implantation during a
25 wide variety of procedures. For example, anterior interbody fusion is a surgical procedure which replaces some or all of a disc with a bony graft (implant) by using an anterior approach to the disc. Such a procedure is typically employed in the cervical spine, and implantation of an implant is an effective modality for the treatment of such conditions as degenerative disc disease and herniated nucleus pulposus (slipped disc). Anterior interbody
30 fusion is also used in the lumbar spine in cases of unsuccessful posterior approaches, or in procedures directed to destroyed or damaged facet joints, procedures that combine posterior instrumentation with an anterior discectomy (i.e. removal of herniated disc material from the spinal canal so that the spinal cord or nerve is restored to an unpinched state) and fusion (which allows vertebrae to effectively be knit together into a solid bony mass), along with
35 other procedures that cannot employ a posterior approach. Thus, the implants may also be employed in anterior discectomy and fusion, which involves the removal of an intervertebral

disc and the replacement of that disc with an implant that will undergo fusion, both steps being undertaken via an anterior approach. Other surgical procedures employing the anterior approach, including procedures used in fusing the thoracic region, may also make use of the implants.

5 Alternatively, surgical procedures involving a posterior approach may also employ the implants created using the current invention. For example, posterior lumbar interbody fusion, another surgical technique used for spinal fusion, involves the posterior insertion of an implant into the intervertebral space following posterior excision of a disc through the spinal canal.

10 Bone stock 25' as shown in FIGS. 1J and 1K may be sectioned, for example, as shown in FIGS. 2A-2D, along axes 43 and 44, resulting in a cross-section slice 45 of bone stock 25' having a thickness X_5 as shown in perspective view in FIG. 2B and in side view in FIG. 2C. In this embodiment, a pair of pins 24 instead is used to retain the pieces of bones 10, 11, 12, and 13 in engagement. Pins 24 may be oriented at an angle with respect to each
15 other, as shown in FIG. 2C, such that they are nonparallel, thereby resisting separation of the bone pieces. Alternatively, the pieces of bone may be keyed (not shown) for additional interlocking. Such composite bone stock may be used, for example, to create an implant suitable for posterior lumbar interbody fusion. Optionally, in order to prevent migration of such an implant when placed in an anatomical region, serrated regions in the form of saw
20 teeth 24' may be provided on the periphery of slice 45. Although slice 45 includes a core 13 that is fully surrounded by sleeve 12, as shown for example in the exploded view of slice 45 in FIG. 2D, alternate embodiments of a slice of bone stock 25' do not completely surround core 13.

 While bone stock 25' utilizes four separate bone pieces, other numbers of
25 pieces are contemplated. For example, a core may be surrounded by only two sleeves to produce a desired stock size. Also, pins 24 may be formed from bone.

 Another composite implant is shown in FIGS. 3A-3D. In this embodiment, a section of a femur 46 has an inner surface 47. Preferably, in order to increase the wall thickness of section 46, this bone section may be used as a sleeve that surrounds a portion of
30 a tibia section 48. Although the tibia naturally has a generally triangular shape, a portion 49 of the tibia 48 may be machined to have an outer geometry that mates with inner surface 47 of femur 46. A canal 50 may remain in the composite implant, or it may be filled with another bone or other material. By inserting portion 49 within sleeve 46, a protruding section 52 remains on tibia section 48. Such a section may be cut off, for example along
35 axis 51, so that section 52 may be used for another purpose, such as serving as bone material for use in other implants.

Yet another approach to maximizing the use of a bone sections with thin wall areas is shown in FIGS. 4A to 4D. In this embodiment, a femur section 53 is cut with a tongue and groove pattern, creating a portion 54 having an acceptable wall thickness and a portion 55 with an unacceptable wall thickness. A similar cut is performed on another femur section, and the portion 55 from the second femur section may be removed and matched with the portion 54 from the first femur section. Thus, a composite implant is created with consistently thick and acceptable wall thickness. Portion 53 may be used for another purpose. In addition to matching tongues 56 and grooves 57 formed in sections 55 and 54, respectively, other matching geometrical shapes such as matching notches 58 may also be provided as shown in FIG. 4E. Other suitable configurations of interlocking portions include interlocking teeth 59 formed in matching sections 54' and 55', as shown in FIGS. 4F and 4G. In an alternate embodiment, a synthetic portion may be matched with a bone portion to create a composite implant with appropriate wall thickness, and may be formed of other materials such as metals, polymers, or ceramics.

FIGS. 5A to 5C show implants created by joining three components. Implant 60 has two outer portions 61 and 62 that surround the cylindrical surface 63 of core 64. Outer portions 61 and 62 are joined to each other using pins 65 and 66 (shown in phantom), and core 64 is press fit or otherwise secured between portions 61 and 62. In the embodiment shown in FIG. 5A, portions 61 and 62 have mating surfaces defined at areas 67 and 68 that do not interfit. Alternatively, as shown in FIG. 5B, implant 69 has two outer portions 70 and 71 that interfit and surround a core 64. Portion 70 has a tongue portion 72 that fits in a groove in portion 71. Likewise, portion 71 is also provided with a tongue portion 73 that fits in a groove in portion 70. Notably, designs employing tongue and groove configurations have a significantly increased mating surface area, thereby providing a greater surface over which joining can be achieved with concomitantly greater strength.

Interfitting may also be achieved using the design of implant 74 shown in FIG. 5C. Portion 75 has protruding portions 76 and 77 that each are partially formed with outside surface 78, while portion 79 has protruding portions 80 and 82 that interfit with protrusions 76 and 77. As shown in FIG. 5D, implant 84 may instead include a combination of tongue portions 86 and 88 that fit within grooves disposed in opposing outer portions, protruding portions 90 and 92, as well as mating surfaces 94 and 96. Implant 98 uses dovetail joints 100 to secure outer portions 102 and 104. The dovetail joint is particularly useful because it resists pullout, although sliding may still occur along axis 106. The dovetails provide a positive lock transverse to axis 106 so that pullout can be prevented, and such an interlocking arrangement of components generally resists the separation of the bone components from each other. As with the tongue and groove design, the use of a dovetail

joint creates a greater surface area for bonding. Although implant 98 is shown with only one dovetail on each outer sheath portion, additional dovetails may be provided.

Additionally, the present development allows the joining of more than two outer portions. Thus, instead of two halves, three or more outer portions may be joined. Furthermore, the
5 core may be of any desired shape, as may be the outside surface of the outer portions. Portions of the implants, such as portions 75 and 79, may be formed of different materials, for example cortical bone, cancellous bone, and ceramic materials.

Numerous types of joints are useful in the present development, including joints that permit articulation such as a ball and socket type of joint, and particularly joints
10 that permit firm interlocking between two components to prevent relative movement between the components. Preferably, mortise and tenon joints can be used to interfit multiple bone components to create an implant as shown for example in FIG. 5F. Bone component 122, shown in exemplary form with a rectangular shape, contains a rectangular mortise or cavity 124. Bone component 126, also rectangular in overall configuration,
15 includes a rectangular-shaped tenon 128 that is inserted in cavity 124 to thereby form a joint. The size and shape of tenon 128 is closely matched to that of cavity 124. Once components 122 and 126 are joined, as shown by arrow A, an implant or larger bone stock is created. The mortise may be partial or extend through the component, and a tenon sloped haunch portion may be provided on the tenon for interfitting with a mortise sloped haunch
20 portion on the mortise. Other forms of the mortise and tenon joints are also appropriate, as are other coupling arrangements such as edge joints including tongue and groove joints, rabbeted joints, toothed joints, and dovetail joints.

The use of insertable securing elements such as keys, pegs, pins, wedges, or other suitable components in joints to assist in securing bone components to each other is
25 also an effective approach to providing a stable joint. Keys, for example, may be inserted in notched or grooved areas in bone components, serving as the securing element between two or more bone components. Parameters that may be varied when using insertable securing elements, such as keys, include the angle of application, the spacing of the elements, and the thicknesses of the elements.

Referring to FIGS. 6A-6D, a femoral ring implant 200 is shown for use in
30 anterior lumbar interbody fusion, and is formed of several layers of bone in the form of sleeves. In the preferred embodiment, a sleeve 202 formed from a femur or tibia has another sleeve 204 formed from a humerus inserted therein. The sleeves 202, 204 may be press-fit, pinned, keyed, and/or joined by other means. Although implant 200 is shown with a central
35 chamber 206, which may be left empty or filled with bone materials or other bone inducing substances, in alternate embodiments central chamber 206 may be filled with another bone

portion to create a solid implant. A cancellous plug, for example, may be placed in central chamber 206. Combinations of cortical or cancellous bone may be used, and additional sleeves may also be provided. Saw teeth 208 or other protrusions may be provided on the periphery of implant 200 to anchor the implant in the desired anatomical region. Implant
5 200 is formed in a generally kidney-shaped configuration to conform to the natural anatomy of vertebral bodies encountered during anterior lumbar interbody fusion.

Alignment indicia 210 may be provided on the outer surface of implant 200, as with a line or other aid. Preferably, indicia 210 is an imprint, *i.e.* with ink, although indicia 210 may instead be provided in the form of surface scoring. The indicia suitable for
10 the present invention includes, but is not limited to, markers such as lines, arrows, lettering, and symbols. In addition, alignment indicia 210 preferably is provided on the anterior side of implant 200 to aid in alignment with the natural anatomy encountered during surgery, and particularly to aid in alignment with the anterior longitudinal ligament (ALL) that extends
over the length of the lumbar spine anterior to the vertebral bodies. In particular, the ALL
15 may be used as a landmark in combination with alignment indicia 210, for example, to permit a surgeon to properly align implant 200 with respect to surrounding anatomy.

Referring to FIGS. 7A to 7C, interlocking concentric circular bone components may also be created from bone stock. For example, concentric bone portions 1020, 1022, 1024, 1026, and 1028 may be combined to form an implant. Some of the
20 concentric circular components may be provided with two portions, each having a different outer diameter such as portion 1047 and ridge 1048. Ridge 1048 has an outer diameter that is slightly smaller than the inner diameter of ridge 1049, thus allowing ridge 1048 of a first component to be press fit into the ridge 1049 of a second component. This permits implants of varying sizes to be created by interlocking several bone components together, for
25 example to create implant 1050. Side and exploded, perspective views of implant 1050 are shown in FIGS. 7B and 7C respectively. Keys may also be inserted into the walls of assembled bone components to provide further interlocking of the concentric cylinders. Furthermore, once assembled and secured to each other, the annular members may be cut to create other appropriate shapes. Implant 1050 utilizes bone portions that are formed from
30 the natural size and overall geometry of particular bones, so that available bone material may be used efficiently. For example, bone portions 1020, 1028 may be formed from a radius, bone portions 1022, 1026 may be formed from a humerus, and bone portion 1024 may be formed from a femur. Although implant 1050 is shown with concentric circular portions, is other embodiments non-circular, ring-shaped bone components may also be
35 similarly provided such as oblong arcuate forms like elliptical shapes, or polygonal shapes.

In some embodiments, caps are optionally provided in the outermost concentric circle bone portions to form a completely-enclosed chamber within implant 1050.

Turning to FIGS. 8A-E, another spacer implant 1100 according to the present invention is shown. Two bone pieces 1102, 1104 are provided with mating portions 1107, 1108 respectively. Once interfitted, bone pieces 1102, 1104 provide a multi-layer, oval-shaped implant structure with a central hole 1112, which may be packed with bone-growth inducing substances. Preferably, one or more of the outer surfaces on implant 1100, such as outer surface 1106, is provided with teeth 1110. In a preferred embodiment, teeth 1110 are pyramidal in shape with edges formed at an angle β of about 60° . Preferably, at least a portion of an inner surface of a bone piece 1102, 1104 is provided with a protrusion that is received in an opposing groove. For example, as shown in FIGS. 8A and 8B, bone piece 1102 is provided with an inner surface that includes a groove 1118 for mating with a symmetrically formed protrusion 1116 on bone piece 1104. Centering lines 1114, 1116 may also be provided on implant 1100 to assist in the orientation and overall placement of implant 1100 in the body. Although the implant 1100 of FIGS. 8A-E is formed of two layers of bone, implants of more than two layers of interfitting bone are contemplated.

Referring to FIGS. 9A-C, various other configurations of bone portions may be provided. For example, an implant 1200 may be formed with interfitting washer 1202 and base 1204 bone pieces. Alternatively, an implant 1220 may be formed with multiple washer-like pieces 1222, 1224 that interfit with a core 1226. In addition, an implant 1240 may be formed with washer-like pieces 1242, 1244, an intermediate piece 1246, and a core 1248 that extends the length of all pieces 1242, 1244, 1246. The mating surfaces of the components of these embodiments may be fixed to each other using any of the aforementioned means such as pins and adhesives. In addition, different types of bone may be selected for the components of these embodiments. In one embodiment, implant 1200 includes a cancellous ring 1202 and a cortical base 1204. In another embodiment, implant 1240 includes cortical washer-like pieces 1242, 1244, a cancellous intermediate piece 1246, and a cortical core 1248.

Another embodiment according to the present invention is shown in FIG. 10. Implant 1260 is formed with bowed bone portions 1262, 1266. Bone portion 1262 is provided with grooved regions 1264, while bone portion 1266 is provided with protrusions 1268 that mate with grooved regions 1264.

Yet another embodiment of an implant 1280 is shown in FIG. 11. An outer bone portion 1282 surrounds an inner bone portion 1284. Advantageously, inner bone portion 1284 only contacts outer bone portion 1282 along two small regions 1286, 1288 along the length of portions 1282, 1284. Thus, in this embodiment a press-fit of bone

portions 1282, 1284 is only provided at regions 1286, 1288. Such a construction permits outer bone portion 1282 to deflect with respect to inner bone portion 1284. Such a construction facilitates press-fitting of outer and inner bone portions. Closely mating outer and inner bone portions may be difficult to press-fit due to the tightness inherent in the fit itself and the dimensions of the bone portions. A less tight fit, as provided for example by implant 1280, may permit a press-fit to be achieved with less difficulty. In sum, an implant 1280 with an inner bone portion 1284 of oblong or slightly elliptical geometry can provide an acceptable interference fit, while facilitating assembly without as much concern for breakage. While a press-fit with two points or regions of contact has been described, it is also contemplated that press-fits with more than two points or regions of contact may be used.

Further embodiments of multipiece implants are shown in FIGS. 12-14. Referring to FIG. 12, implant 1300 is formed of bone portions 1310, 1312, and 1314. Bone portion 1310 includes a central hole or recess 1316 with a diameter D_1 , while bone portion 1312 includes a prong 1320 with a diameter D_2 and a central hole or recess 1318 with a diameter D_3 . Diameters D_1 , D_2 are chosen such that bone portions 1310 and 1312 mate at hole 1316 and prong 1320, and preferably a press-fit is achieved. Similarly, bone portion 1314 includes a prong 1322 with a diameter D_4 and a central hole or recess 1324. Diameters D_3 , D_4 are chosen such that bone portions 1312 and 1314 mate at hole 1318 and prong 1322, and preferably a press-fit is achieved. In the embodiment shown, diameters D_2 , D_4 are chosen to be different. Thus, if an implant requires a central cancellous bone portion 1312 between cortical bone portions 1310, 1314, the proper construction is more likely to be achieved due to the specific interfitting relationships of the bone portions.

As shown in FIGS. 13-14, a multi-layer implant 1330 includes a core bone portion 1332 surrounded by bone portions 1334, 1336, 1338, 1340. The shape of core bone portion 1332 serves as a key for orienting and mating with bone portions 1334, 1336, and similarly bone portions 1334, 1336 together serve as a key for orienting and mating with bone portions 1338, 1340. Any number of bone portions may be aligned with respect to each other using this key configuration.

Referring now to FIGS. 15-16, the use of cortical bone struts to confer additional structural strength to implants is shown. For example, implant 1350 of FIG. 15 includes a cancellous body 1352 with holes 1353 formed therein. Cortical struts 1354 are inserted in holes 1353 to improve the strength of implant 1350. In particular, because cancellous bone does not provide significant structural strength, cortical struts with higher structural strength, particularly in compression, are used. Advantageously, implant 1350 is formed in part from an osteoconductive material, the cancellous bone, to facilitate

incorporation of the implant into surrounding bone tissue. Implant 1350 may be formed of bone that is demineralized, partially demineralized, or with natural mineral content, and may be formed from other shapes. Holes 1353 and struts 1354 may have other cross-sections such as triangular or rectangular shapes, and similarly body 1352 may be another shape. A central hole 1355 also may be included and additional materials may be packed or molded therein. Turning to FIG. 16, an exploded view of an implant 1360 is shown. Implant 1360 includes cortical end caps 1362, 1364 disposed on opposing sides of body 1368. Cortical struts 1366 extend through holes 1370 in body 1368 to improve structural integrity of the implant. One or both of end caps 1362, 1364 may include holes or recesses, such as holes 1372 as shown in end cap 1364, to receive portions of struts 1366. The struts may be press-fit within holes 1370, 1372. Cortical end caps 1362, 1364 also serve to distribute loading on implant 1360.

Additional embodiments of implants with combinations of cortical and cancellous bone are shown in FIGS. 17-18. Implant 1380 includes opposing cortical caps 1382 each with heads 1384 and protrusions 1386. Cancellous body 1390 includes opposing recesses or holes 1390, which receive protrusions 1386 of caps 1382. Implant 1392 includes cortical shells 1394, 1396 with a cancellous body 1398 disposed therebetween. A central region 1399 may be empty, filled with a plug of bone material such as cancellous bone, or filled with other materials.

Implants may be formed from composites of bone material and material that is molded thereto. For example, femur section 46 shown in FIG. 3A has an inner surface 47 that conforms to the natural shape of the femur bone canal. The wall thickness of femur 46 varies, and may be increased using several approaches. As shown in FIGS. 19A and 19B, a molding apparatus 1400 may be used to produce an implant 1410 with desired wall thickness. A mold 1402 or object of smaller dimension than the hole 1404 defined by inner surface 47 of femur section 46, and a curable liquid, slurry, paste, or gel such as bone cement, a viscous polymer, or a ceramic slurry can be poured between mold 1402 and inner surface 47 and allowed to set in place. Alternatively, or in addition, a mold 1406 with a larger dimension than femur section 46 may be placed around it. The wall thickness of femur section 46 may be increased by pouring bone cement between mold 1406 and outer surface 1408, so that the bone cement extends from the top surface 1407 to the bottom surface 1409. In alternate embodiments, the bone cement may not extend to top surface 1407.

Once the bone cement has set, molds 1402, 1406 may be removed, leaving a tissue form 1410 with a composite wall of the original femur section 46 and bone cement sections 1412, 1414. Other filler materials can be used with molds 1402, 1406, such as a

mixture of hydroxyapatite and cement that sets in place. In alternate embodiments, materials are molded only to portions of bone sections, instead of being molded to completely surround inner and/or outer surfaces of bone sections. Additional molds can be used for surrounding adjacent bone sections in implants formed with multiple pieces of
5 bone, thereby permitting multiple bone sections to be coupled together with an intermediary layer of bone cement.

Molded sections such as sections 1412, 1414 may include mixtures or suspensions of cancellous and/or cortical bone powder, bone chips, and bone fibers, in natural or demineralized conditions, in combination with bonding agents such as bone
10 cements, water, fat, blood, thrombin, and fibrin. The fibers, in particular, may be oriented to provide particular mechanical properties. For example, fibers may be oriented generally parallel to axis 1416, transverse to axis 1416, or in mixed orientations in order to achieve desired strength when encased in bone cement that is cured. Other materials also may be combined with bonding agents or other carriers, such as hydroxyapatite. Furthermore,
15 sections 1412, 1414 may additionally be formed by applying pressure while curing occurs.

Alternatively, compactable powders and/or fibers of various sizes and shapes may be pressed and compacted in place, without bonding agents or with minimal use thereof. Such pressed structures may be further encapsulated in thin layers of bone cements or polymers such as biodegradable polymers. While loose powder of varying particle sizes
20 may be compressed and densified to produce a compact of the powder, it is difficult to apply uniform pressures while producing the compact. The so-called "single action" pressing technique, which typically applies a force to the powder in a single direction, may be used in the present invention. However, in some embodiments, because it is desirable to produce a compact with a more uniform density throughout the structure, other pressing techniques
25 may be used.

Furthermore, the components of the implants described herein may be formed by molding various materials onto support structures such as meshes or other structures that are known to one skilled in the art. For example, titanium mesh indicated for reinforcement of bony regions in orthopedic procedures is typically available in preformed
30 round and oval-shaped cylinders. The metal mesh may be encapsulated or otherwise surrounded by another material such as bone powder or bone fiber impregnated bone cement that has dried in place around the mesh. Multiple bone components may be interfitted together and further encapsulated or otherwise surrounded by molded materials for additional reinforcement. Also, molded material may be used to further couple two or more
35 pieces of bone together. For example, a polymer such as polymethylmethacrylate may be placed in the central chamber of an implant and allowed to cure in place.

While various descriptions of the present invention are described above, it should be understood that the various features can be used singly or in any combination thereof. The various types of joints and connections can be used on bone implants or bone stock of different size or configuration, such that the invention is not to be limited to only
5 the specifically preferred embodiments depicted in the drawings.

Further, it should be understood that variations and modifications within the spirit and scope of the invention may occur to those skilled in the art to which the invention pertains. For example, multiple, differently shaped and sized bone portions can be constructed for interfitting or interconnection to form a multiple part bone implant that
10 serves the desired purpose. Accordingly, all expedient modifications readily attainable by one versed in the art from the disclosure set forth herein are within the scope and spirit of the present invention and are to be included as further embodiments. The scope of the present invention is accordingly defined as set forth in the appended claims.

15

20

25

30

35

The Claims

What is claimed is:

- 5 1. An implant comprising a body having an inner sheath and at least one outer sheath, each sheath being formed from a different bone and having an interior surface and an exterior surface, wherein the exterior surface of each outer sheath contacts the interior surface of no more than one other outer sheath.
- 10 2. The implant of claim 1, further comprising a core disposed in the inner sheath and formed from a bone other than the bones of the sheaths.
3. The implant of claim 2, wherein the core is formed of cancellous bone and at least one sheath is formed of cortical bone.
- 15 4. The implant of claim 2, wherein at least one sheath is formed of cancellous bone and the core is formed of cortical bone.
5. The implant of claim 2, wherein the bones comprise at least one of
- 20 autograft, allograft, and xenograft bone tissue.
6. The implant of claim 5, wherein the bone tissue of at least one bone is partially demineralized or demineralized.
- 25 7. The implant of claim 2, wherein the body comprises a cross-section of the sheaths and core, the cross-section including at least a portion of each sheath and core.
8. The implant of claim 7, wherein the sheaths and core are coupled together with at least one fastener.
- 30 9. The implant of claim 8, wherein the at least one fastener is selected from a screw, key, pin, peg, rivet, cotter, nail, spike, bolt, stud, staple, boss, clamp, clip, dowel, stake, hook, anchor, tie, band, crimp, and wedge.
- 35 10. The implant of claim 8, wherein the at least one fastener intersects each of the sheaths and core.

11. The implant of claim 7, wherein at least two of the sheaths and core are bonded together with a bonding agent.
12. The implant of claim 2, wherein at least one of the inner sheath, an
5 outer sheath, and the core is at least partially dehydrated to fit against a surrounding mating surface.
13. The implant of claim 2, wherein at least one of the inner sheath, an
outer sheath, and the core is at least partially dehydrated to fit within a surrounding inner
10 sheath or outer sheath having a greater moisture content.
14. The implant of claim 1, wherein contacting surfaces of adjacent
sheaths are machined surfaces so that the contour of the contacting surfaces is about the
same.
15
15. The implant of claim 14, wherein the machined surfaces permit press-
fitting of one sheath into another sheath.
16. The implant of claim 1, wherein the bones are selected from a femur,
20 tibia, humerus, fibula, ulna, and radius.
17. The implant of claim 1, further comprising at least one supplemental
sheath having an interior surface and an exterior surface, wherein the exterior surface of
each supplemental sheath contacts the interior surface of no more than one other sheath and
25 the interior surface of each supplemental sheath contacts the exterior surface of no more than
one other sheath, wherein the at least one supplemental sheath is formed of a material
selected from metals, alloys, ceramics, polymers, and composites.
18. The implant of claim 1, wherein at least one sheath is packed with
30 bone growth materials.
19. The implant of claim 1, wherein at least one sheath further comprises
alignment indicia.
20. The implant of claim 1, wherein the exterior surface is spaced from a
35 portion of the interior surface.

21. An implant comprising a body formed from a cross-section of a core and a plurality of sheaths with each sheath having an inner surface and an outer surface, wherein at least two sheaths are formed from different bones, the outer surface of a first sheath has about the same contour as the inner surface of a second sheath so that the first and second sheaths mate together, and the cross-section includes at least a portion of each sheath and core.

22. The implant of claim 21, wherein the core is formed from a bone other than the bones of the sheaths.

10

23. The implant of claim 22, wherein the core is formed of cancellous bone and at least one sheath is formed of cortical bone.

24. The implant of claim 22, wherein at least one sheath is formed of cancellous bone and the core is formed of cortical bone.

25. The implant of claim 22, wherein the bones comprise at least one of autograft, allograft, and xenograft bone tissue.

26. The implant of claim 25, wherein the bone tissue of at least one bone is partially demineralized or demineralized.

27. The implant of claim 22, wherein the sheaths and core are coupled together with at least one fastener.

25

28. The implant of claim 27, wherein the at least one fastener is selected from a screw, key, pin, peg, rivet, cotter, nail, spike, bolt, stud, staple, boss, clamp, clip, dowel, stake, hook, anchor, tie, band, crimp, and wedge.

29. The implant of claim 27, wherein the at least one fastener intersects each of the sheaths and core.

30. The implant of claim 22, wherein the sheaths and core are bonded together with a bonding agent.

35

31. The implant of claim 22, wherein at least one of the first sheath, second sheath, and core is at least partially dehydrated to fit against a surrounding mating surface.
- 5 32. The implant of claim 22, wherein at least one of the first sheath, second sheath, and core is at least partially dehydrated to fit within a surrounding first sheath or second sheath.
- 10 33. The implant of claim 21, wherein contacting surfaces of adjacent sheaths are machined surfaces so that the contour of the contacting surfaces is about the same.
- 15 34. The implant of claim 33, wherein the machined surfaces permit press-fitting of one sheath into another sheath.
35. The implant of claim 21, wherein the bones are selected from a femur, tibia, humerus, fibula, ulna, and radius.
- 20 36. The implant of claim 21, further comprising at least one supplemental sheath having an interior surface and an exterior surface, wherein the exterior surface of each supplemental sheath contacts the interior surface of no more than one other sheath and the interior surface of each supplemental sheath contacts the exterior surface of no more than one other sheath, wherein the at least one supplemental sheath is formed of a material selected from metals, alloys, ceramics, polymers, and composites.
- 25 37. The implant of claim 21, wherein at least one sheath is packed with bone growth materials.
- 30 38. The implant of claim 21, wherein at least one sheath further comprises alignment indicia.
- 35 39. The implant of claim 21, wherein the outer surface is separated from a portion of the inner surface.

40. An implant comprising a body having at least one sheath defining a hole with a core fit therein, wherein the body is formed from at least two different bones selected from a femur, tibia, humerus, fibula, ulna, and radius.
- 5 41. An implant comprising at least two layers of bone components coupled to each other, the components together defining at least one securing region, and at least one insertable securing element adapted for placement in the at least one securing region.
- 10 42. The implant of claim 41, wherein the at least one securing region is a recess or hole.
43. The implant of claim 42, wherein the insertable securing element is a screw, key, pin, peg, rivet, cotter, nail, spike, bolt, stud, staple, boss, clamp, clip, dowel,
15 stake, hook, anchor, tie, band, crimp, or wedge.
44. The implant of claim 42, wherein each layer is formed from a different bone selected from a femur, tibia, humerus, fibula, ulna, and radius.
- 20 45. The implant of claim 44, wherein at least one layer is formed of cancellous bone and at least one layer is formed of cortical bone.
46. The implant of claim 45, wherein the layers comprise at least one of autograft, allograft, and xenograft bone tissue.
- 25 47. The implant of claim 46, wherein the bone tissue of at least one bone is partially demineralized or demineralized.
48. The implant of claim 42, wherein the layers are bonded together with
30 a bonding agent.
49. The implant of claim 42, wherein a first layer is at least partially dehydrated to mate against at least one other layer.
- 35 50. The implant of claim 42, wherein adjacent layers are provided with mutually contacting surfaces that are machined to have about the same contour.

51. The implant of claim 42, wherein the contacting surfaces of adjacent layers are press-fit together.

52. The implant of claim 42, further comprising at least one supplemental layer coupled to at least one of the layers of bone components, wherein the at least one supplemental layer is formed of a material selected from metals, alloys, ceramics, polymers, and composites.

53. The implant of claim 41, wherein the implant further comprises a chamber packed with bone growth materials.

54. The implant of claim 41, wherein at least one layer further comprises alignment indicia.

55. The implant of claim 41, wherein the outer surface is separated from a portion of the inner surface.

56. An implant comprising a body having two outer annular members and at least one inner annular member, wherein at least one of the annular members is formed from bone and the annular members are coupled together to define a central chamber.

57. The implant of claim 56, wherein each annular member has at least one surface that is press-fit with the surface of another annular member.

58. The implant of claim 57, wherein the outside diameter of the outer annular members is smaller than the outside diameter of the at least one inner annular member.

59. The implant of claim 57, wherein the implant is symmetrical about an innermost annular member, the diameter of the implant progressively decreasing from the innermost annular member to each outer annular member.

60. The implant of claim 57, wherein the central chamber is packed with at least one of bone material and bone inducing substances.

35

61. The implant of claim 57, wherein at least one annular member is formed of cancellous bone and at least one annular member is formed of cortical bone.

5 62. The implant of claim 57, wherein the annular member bones comprise at least one of autograft, allograft, and xenograft bone tissue.

63. The implant of claim 62, wherein the bone tissue of at least one bone is partially demineralized or demineralized.

10 64. The implant of claim 57, wherein a plurality of annular members are coupled together with at least one fastener.

65. The implant of claim 64, wherein the at least one fastener is selected from a screw, key, pin, peg, rivet, cotter, nail, spike, bolt, stud, staple, boss, clamp, clip,
15 dowel, stake, hook, anchor, tie, band, crimp, and wedge.

66. The implant of claim 57, wherein a plurality of annular members are bonded together with a bonding agent.

20 67. The implant of claim 57, wherein at least one of the annular members is at least partially dehydrated to fit against a surrounding mating surface.

68. The implant of claim 57, wherein at least one of the annular members is at least partially dehydrated to mate with another annular member.

25

69. The implant of claim 56, wherein contacting surfaces of adjacent annular members are machined surfaces so that the contour of the contacting surfaces is about the same.

30 70. The implant of claim 69, wherein the machined surfaces permit press-fitting of one sheath into another sheath.

71. The implant of claim 56, wherein the annular member bones are selected from a femur, tibia, humerus, fibula, ulna, and radius.

35

72. The implant of claim 56, wherein the annular members are non-circular.
73. The implant of claim 72, wherein the annular members are generally oblong.
74. The implant of claim 56, further comprising at least one supplemental annular member coupled to at least one of the annular members formed from bone, wherein the at least one supplemental annular member is formed of a material selected from metals, alloys, ceramics, polymers, and composites.
75. The implant of claim 56, wherein at least one annular member further comprises alignment indicia.
76. The implant of claim 56, wherein adjacent surfaces of at least two annular members do not completely contact each other.
77. An implant comprising a body having at least two ring-shaped members formed from bone that are coupled together to define a central chamber.
78. The implant of claim 77, wherein the ring-shaped members have surfaces that mate and press-fit together.
79. The implant of claim 77, further comprising a pair of members each being coupled to a different outermost ring, wherein the chamber is closed on all sides.
80. An implant comprising a hollow body having a minimum wall thickness, the body formed from a plurality of portions of bone sections with each section having a thick-walled portion and a thin-walled portion, the thick-walled portion having a wall thickness at least as thick as the minimum wall thickness and the thin-walled section having a wall thickness less than the minimum wall thickness, wherein only thick-walled portions are coupled together to form the body.
81. The implant of claim 80, wherein the thick-walled portions are coupled together with at least one portion having a first coupling and at least one portion

having a second coupling, and wherein the portions are joined together by interfitting together the first and second couplings.

5 82. The implant of claim 81, wherein at least one coupling is at least partially dehydrated to mate against another coupling.

83. The implant of claim 80, wherein the first coupling is a male coupling and the second coupling is a female coupling so that the portions are mated in a male-female relationship.

10

84. The implant of claim 83, wherein the male coupling is a tenon and the female coupling is a mortise.

85. The implant of claim 83, wherein the male coupling is a tongue and 15 the female coupling is a groove.

86. The implant of claim 83, further comprising an insertable securing element for further coupling the portions to each other, the securing element selected from a screw, key, pin, peg, rivet, cotter, nail, spike, bolt, stud, staple, boss, clamp, clip, dowel, 20 stake, hook, anchor, tie, band, crimp, and wedge.

87. The implant of claim 83, wherein the bone sections are formed from bone selected from a femur, tibia, humerus, fibula, ulna, and radius.

25 88. The implant of claim 80, wherein each bone section is formed of cancellous bone.

89. The implant of claim 80, wherein each bone section is formed of cortical bone.

30

90. The implant of claim 80, wherein the body comprises at least one of autograft, allograft, and xenograft bone tissue.

91. The implant of claim 90, wherein the bone tissue of at least one bone 35 is partially demineralized or demineralized.

92. The implant of claim 80, wherein the bone sections are bonded together with a bonding agent.

93. The implant of claim 80, wherein the bone sections are provided with
5 mutually contacting surfaces that are machined to have about the same contour.

94. The implant of claim 93, wherein the contacting surfaces of adjacent bone surfaces are press-fit together.

10 95. The implant of claim 80, further comprising at least one supplemental portion coupled to at least one of the portions of bone sections, wherein the at least one supplemental portion is formed of a material selected from metals, alloys, ceramics, polymers, and composites.

15 96. The implant of claim 80, wherein at least one of the portions is at least partially dehydrated to mate with another portion.

97. The implant of claim 80, wherein the hollow body is packed with bone growth materials.

20

98. The implant of claim 80, wherein at least one portion further comprises alignment indicia.

25 99. An implant comprising:
a layer formed of a first bone; and
at least one layer formed by a curable carrier,
wherein the at least one layer is molded to the first bone.

30 100. The implant of claim 99, wherein the layer formed of a first bone comprises a primary sleeve with a top surface, a bottom surface, an inner surface, and an outer surface, and wherein the at least one layer of curable carrier is molded to the inner surface or the outer surface.

35 101. The implant of claim 100, wherein the curable carrier further comprises bone or ceramic in powder, chips, or fibers.

102. The implant of claim 100, further comprising at least one secondary sleeve, each secondary sleeve being coupled to a primary sleeve or another secondary sleeve by a layer of curable carrier.

5 103. A method of forming an implant comprising:
surrounding at least a portion of a bone section with a first mold to create a cavity therebetween;
filling the cavity with a first substance, and
coupling the first substance to the bone section.

10 104. The method of claim 103, wherein the first substance is at least one of a curable carrier, bone powder, bone chips bone fibers, or ceramic.

15 105. The method of claim 104, wherein the first substance is coupled to the bone section by curing.

106. The method of claim 104, wherein the first substance is coupled to the bone section by compaction.

20

25

30

35

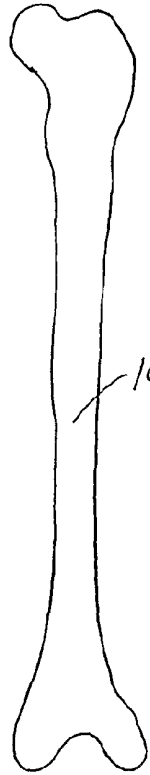

FIG. 1A

PRIOR ART

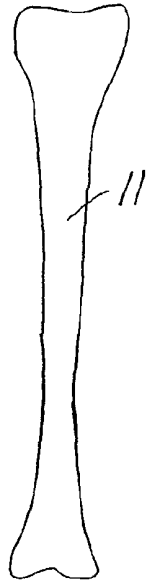

FIG. 1B

PRIOR ART

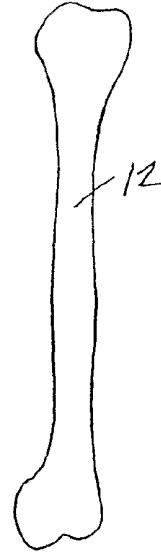

FIG. 1C

PRIOR ART



FIG. 1D

PRIOR ART

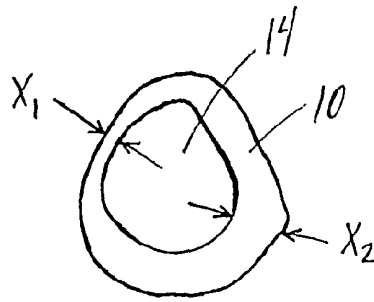

FIG. 1E

PRIOR ART

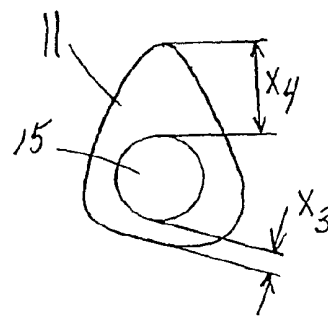

FIG. 1F

PRIOR ART

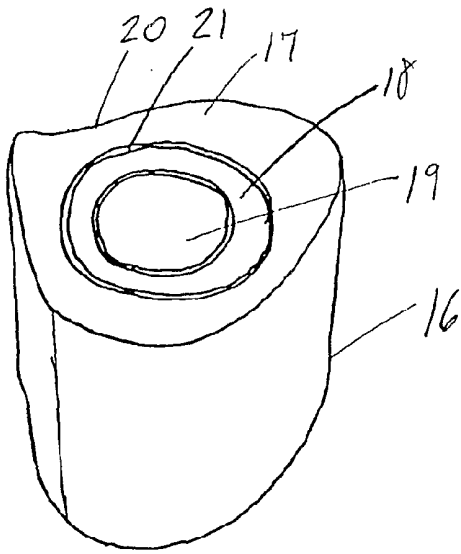

FIG. 1G

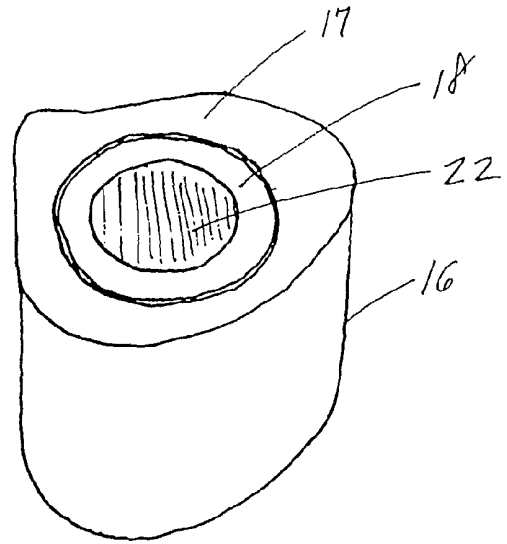

FIG. 1H

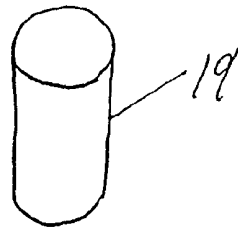

FIG. 1I

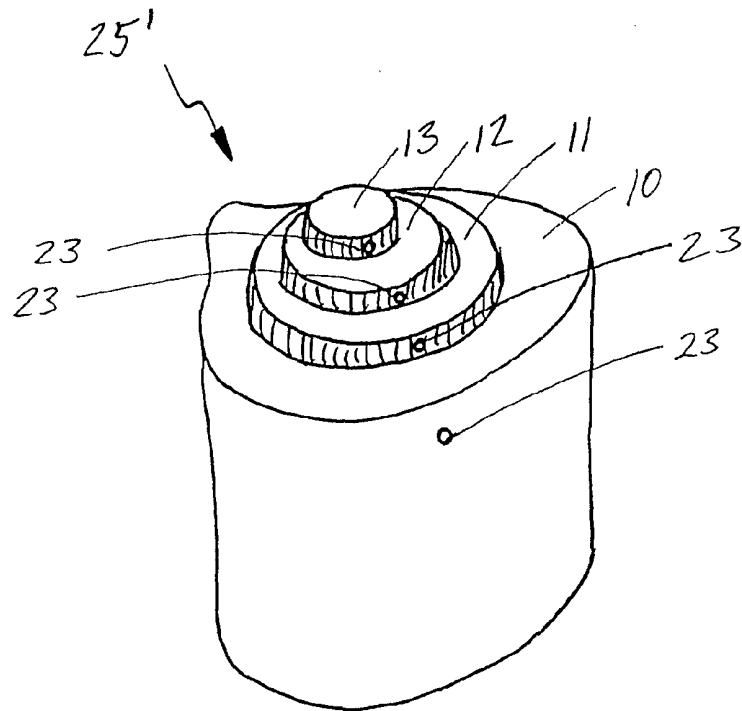

FIG. 1J

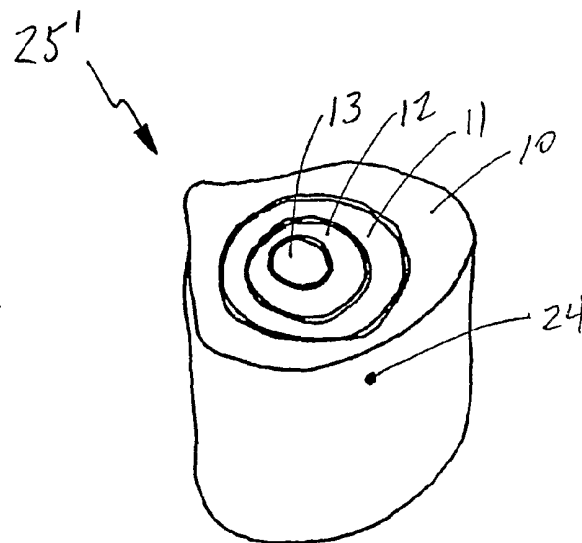

FIG. 1K

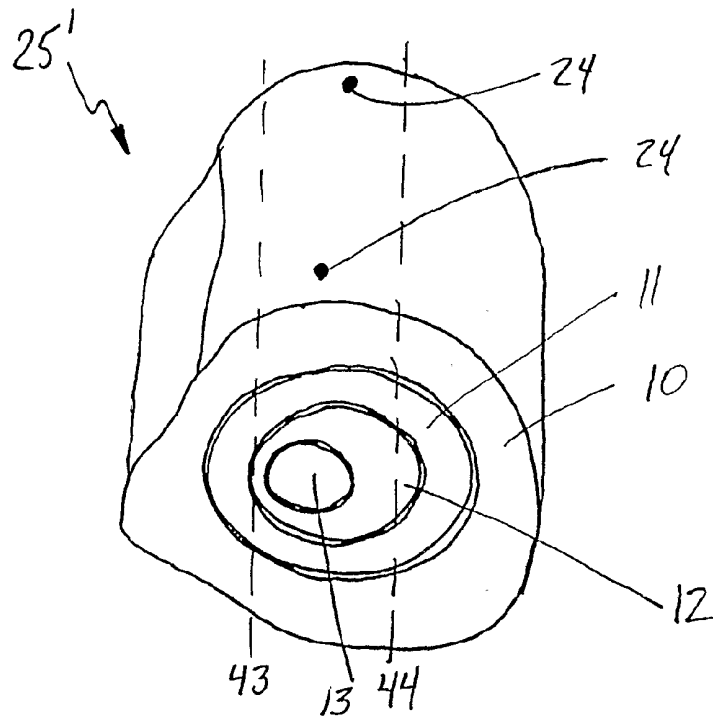

FIG. 2A

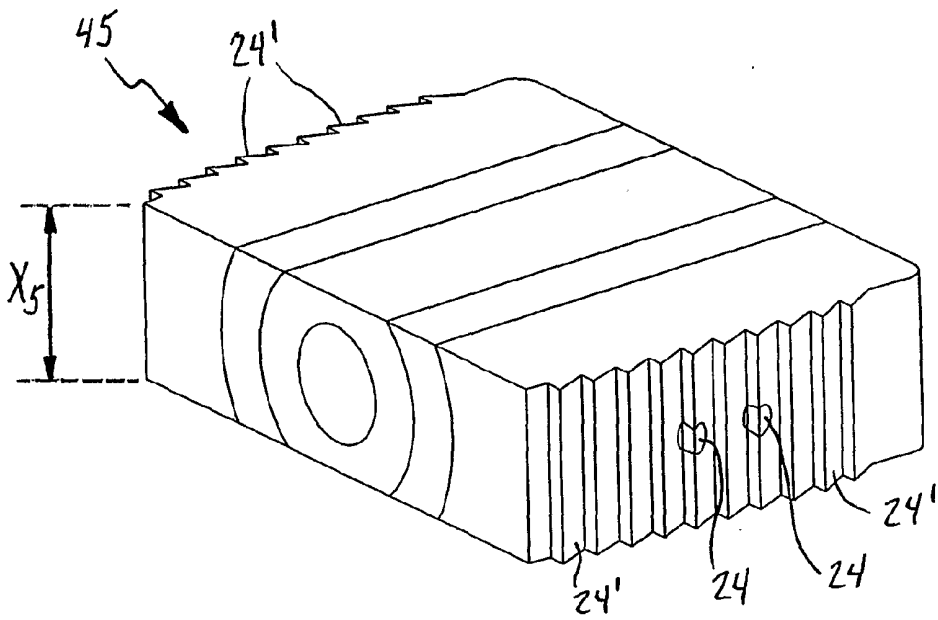

FIG. 2B

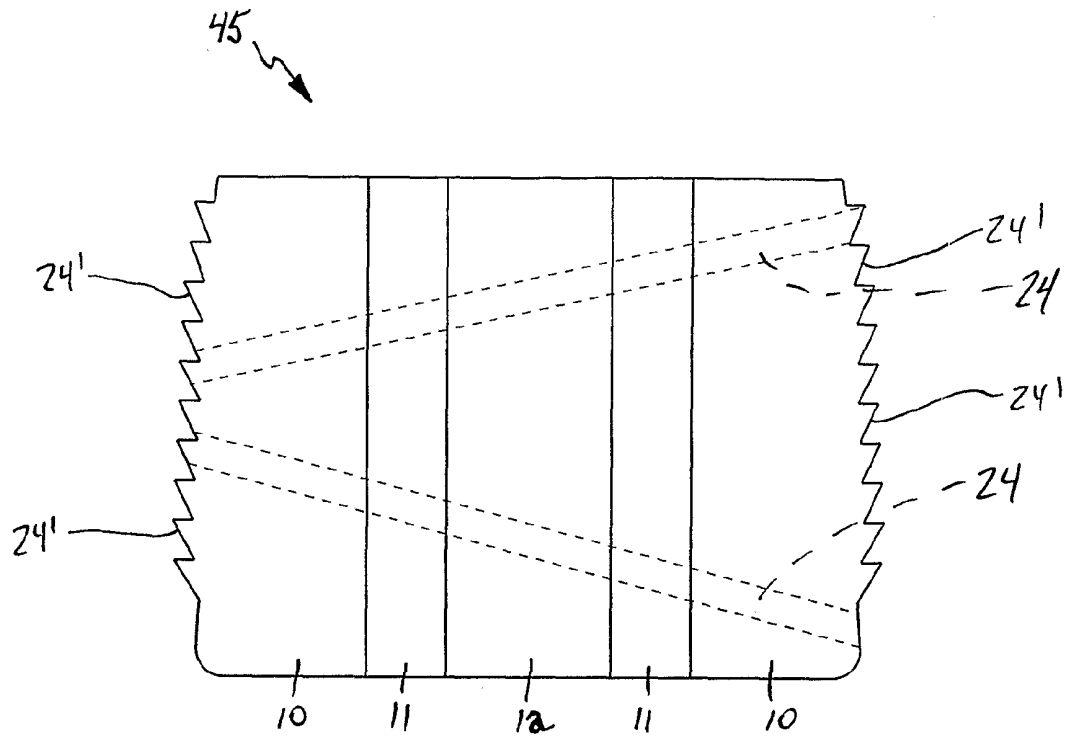

FIG. 2C

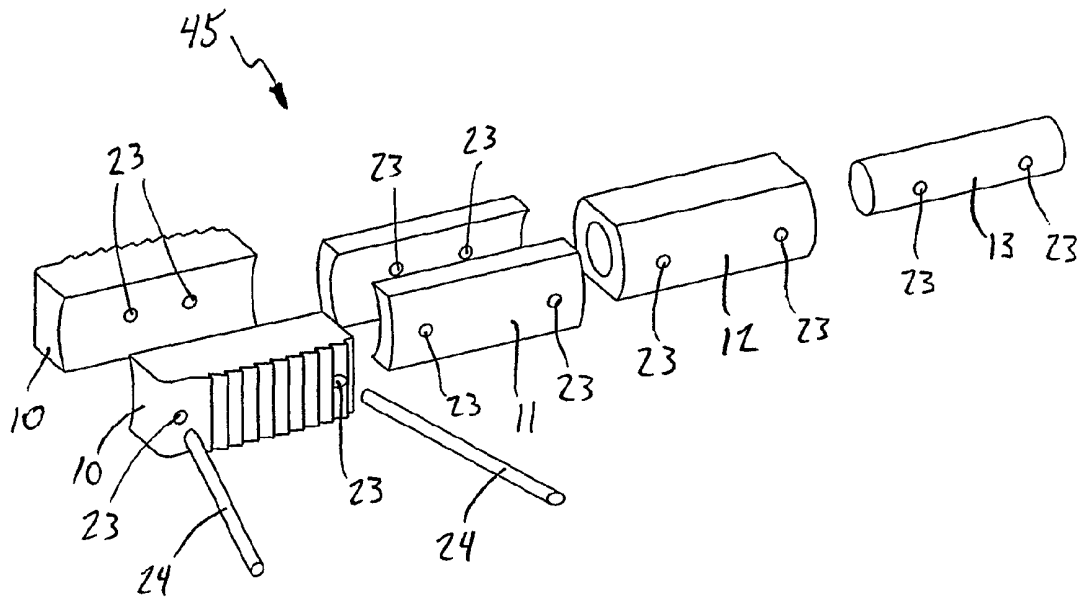

FIG. 2D

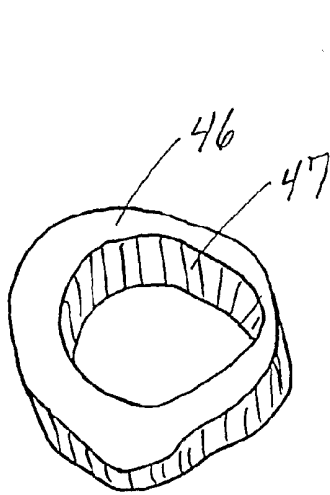

FIG. 3A

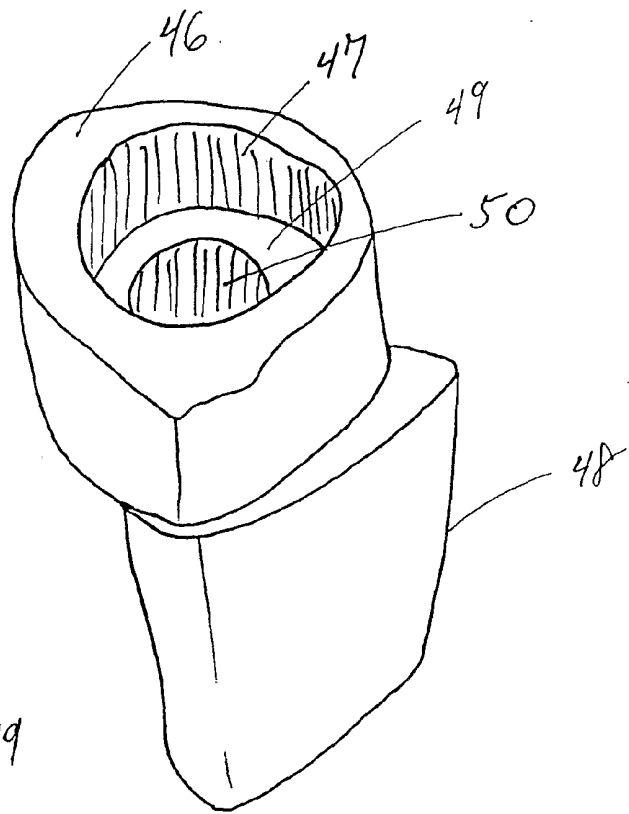

FIG. 3B

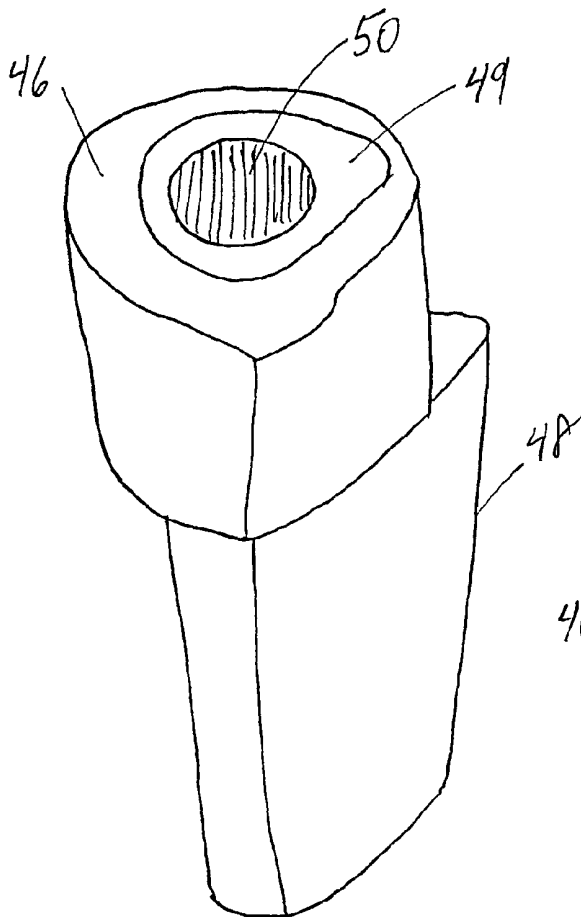

FIG. 3C

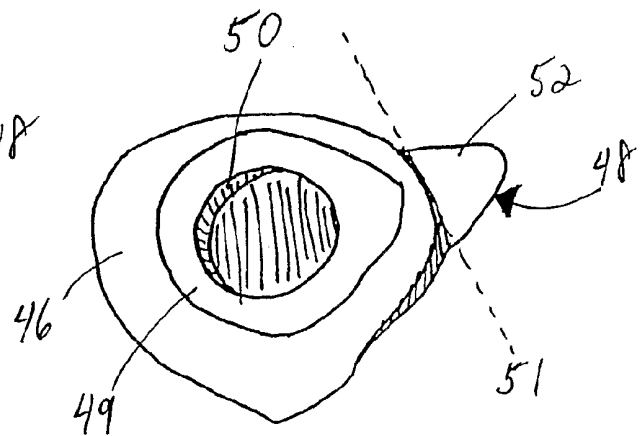

FIG. 3D

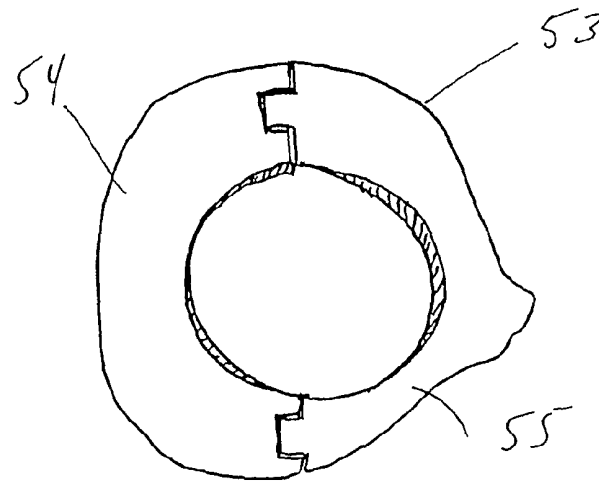

FIG. 4A

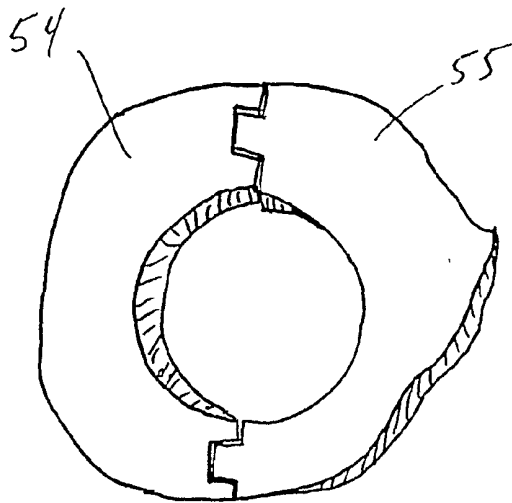

FIG. 4B

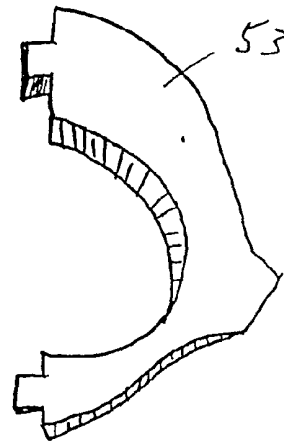

FIG. 4C

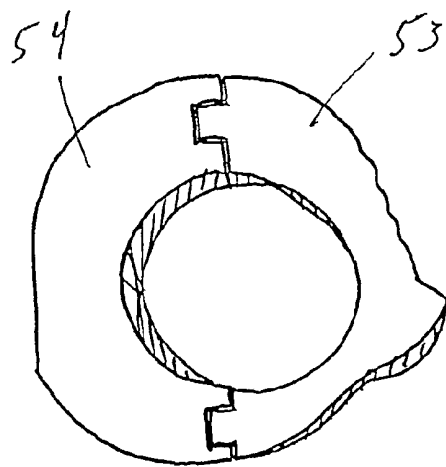

FIG. 4D

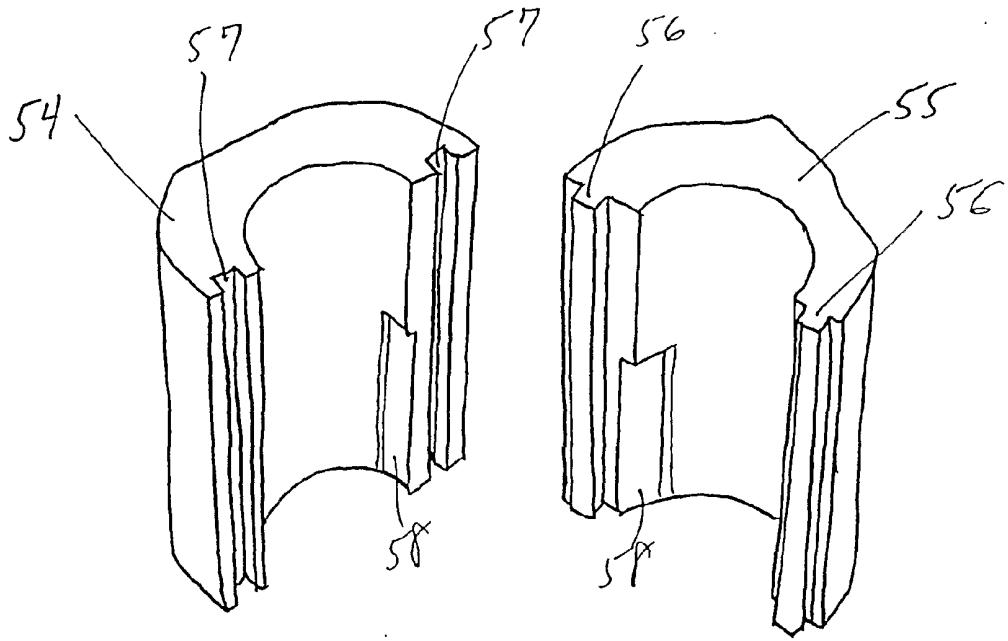

FIG. 4E

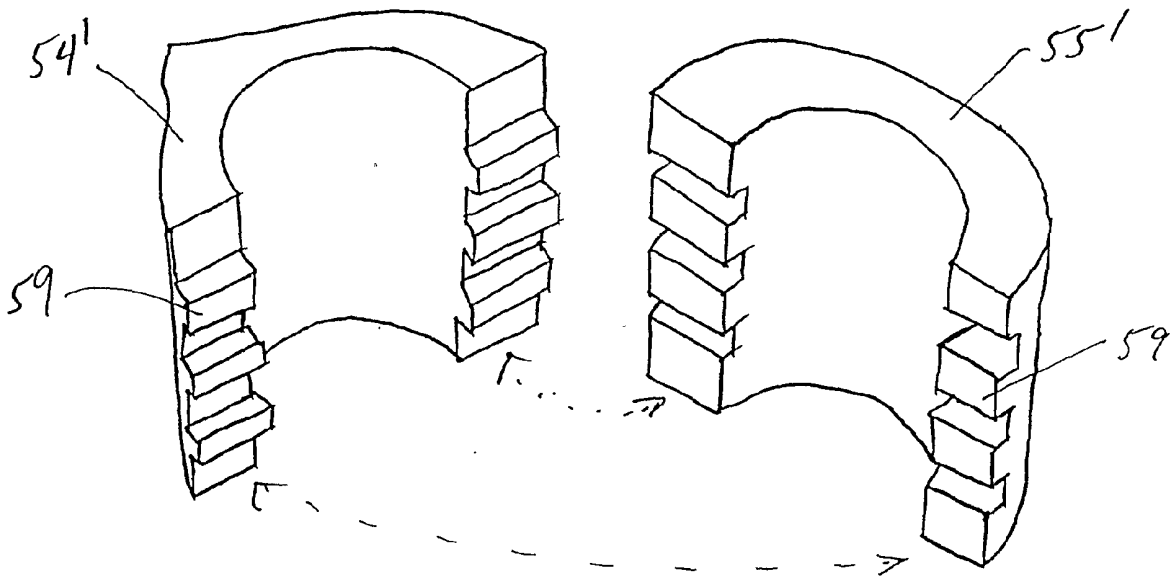

FIG. 4F

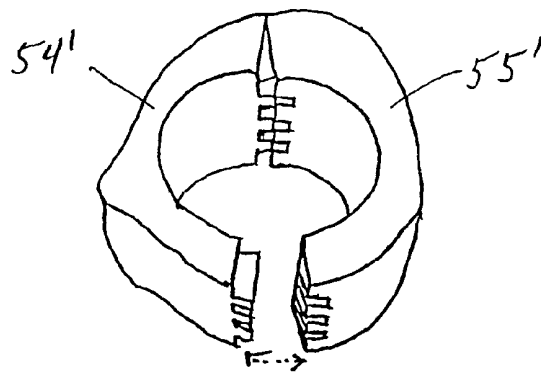

FIG. 4G

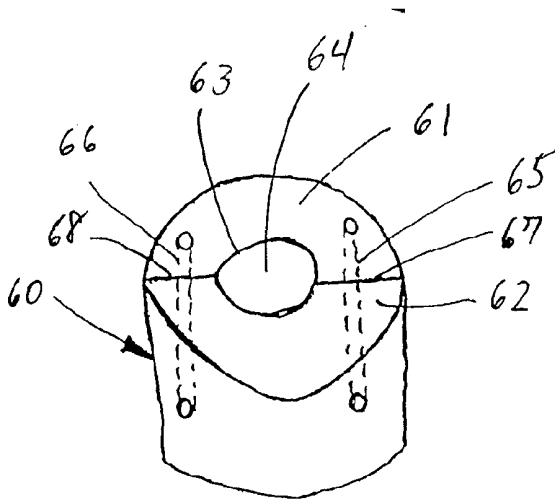

FIG. 5A

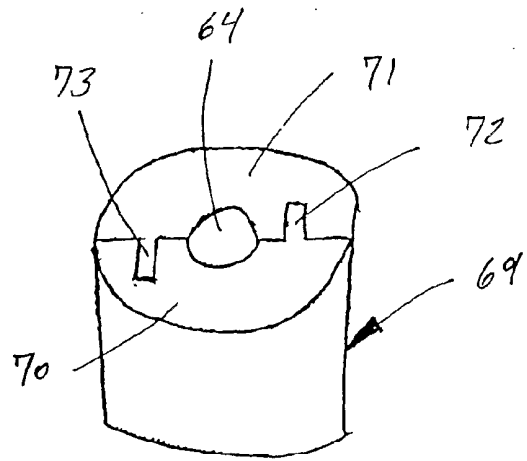

FIG. 5B

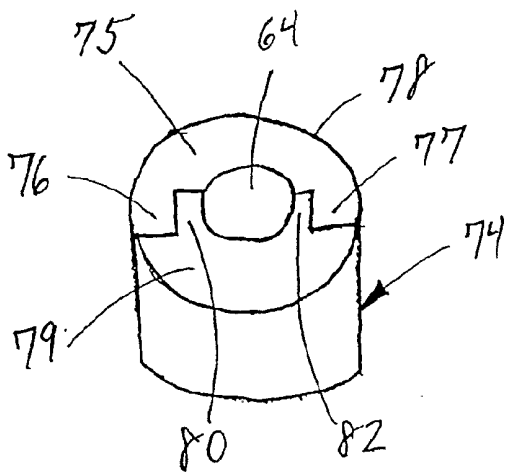

FIG. 5C

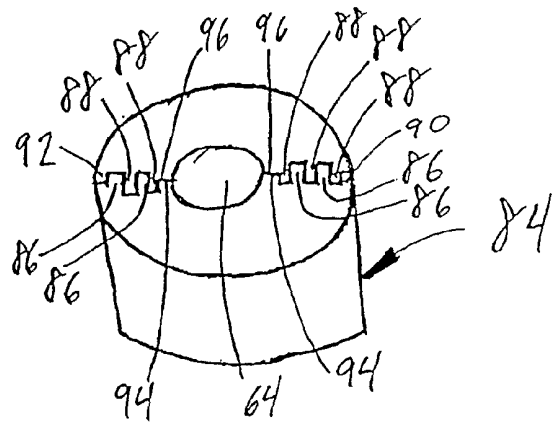

FIG. 5D

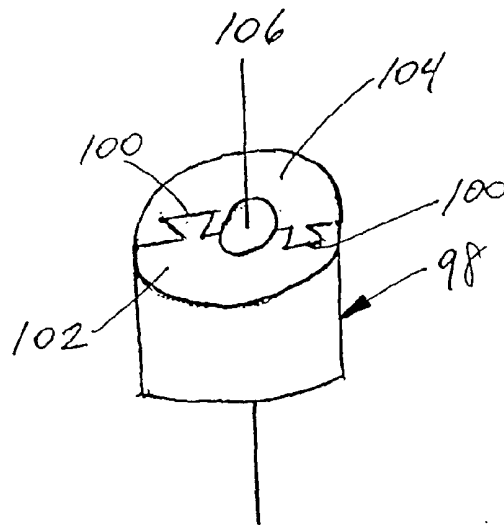

FIG. 5E

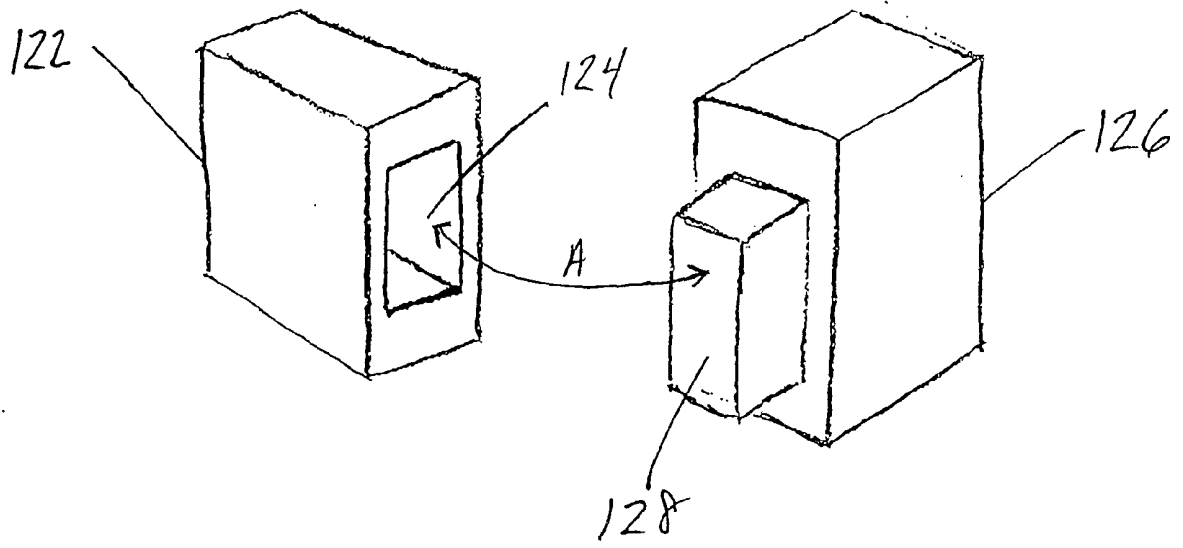

FIG. 5F

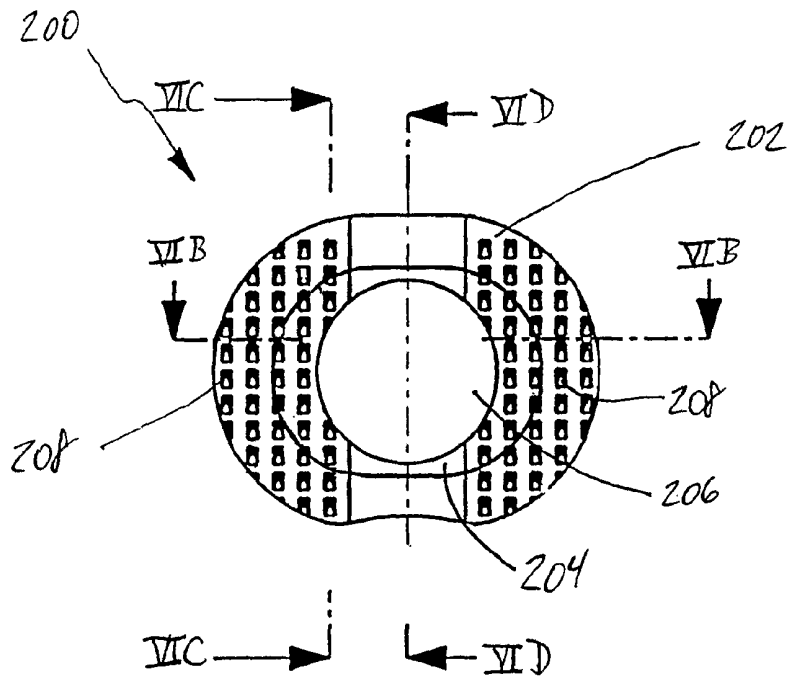

FIG. 6A

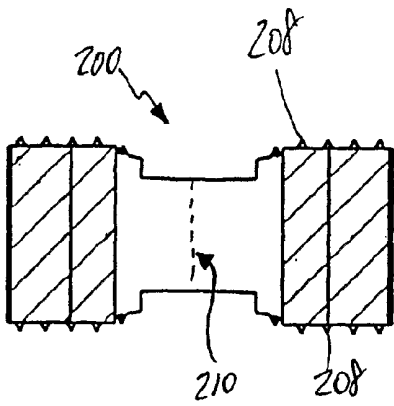

FIG. 6B

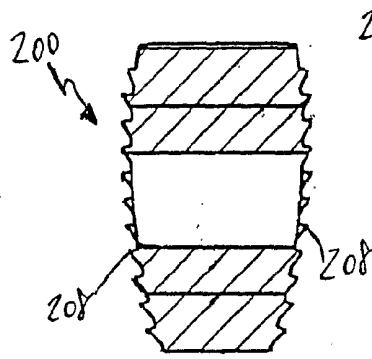

FIG. 6C

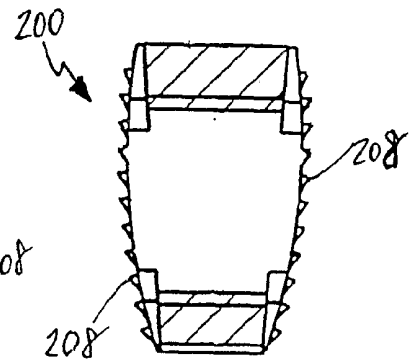

FIG. 6D

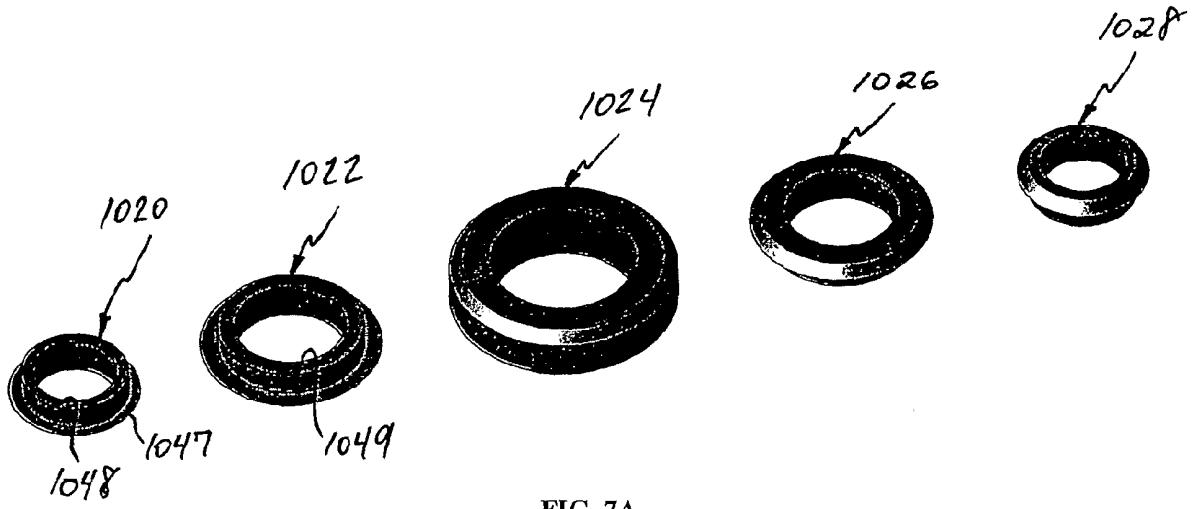

FIG. 7A

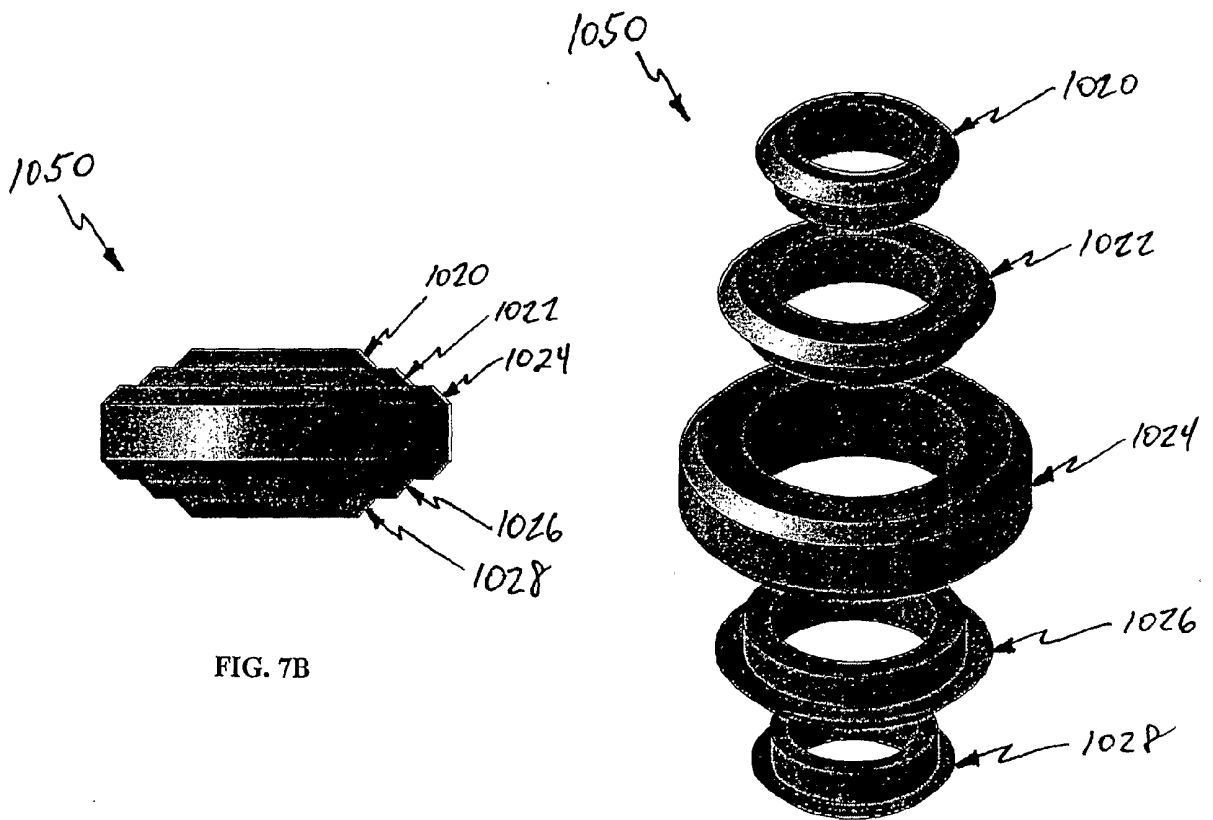

FIG. 7B

FIG. 7C

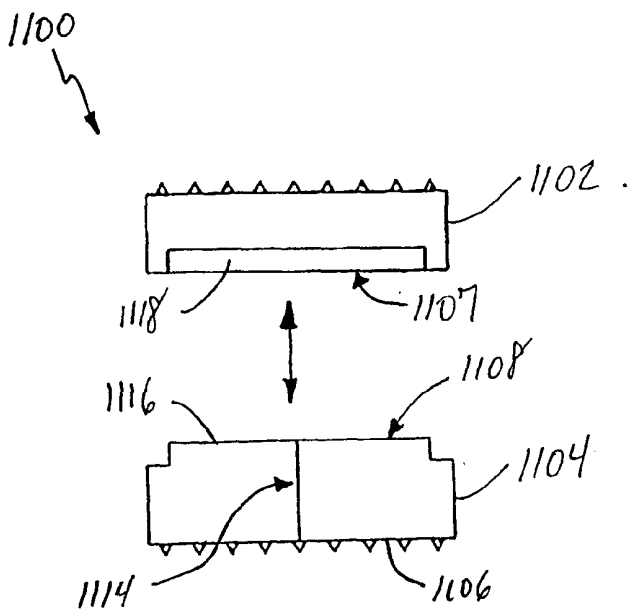

FIG. 8A

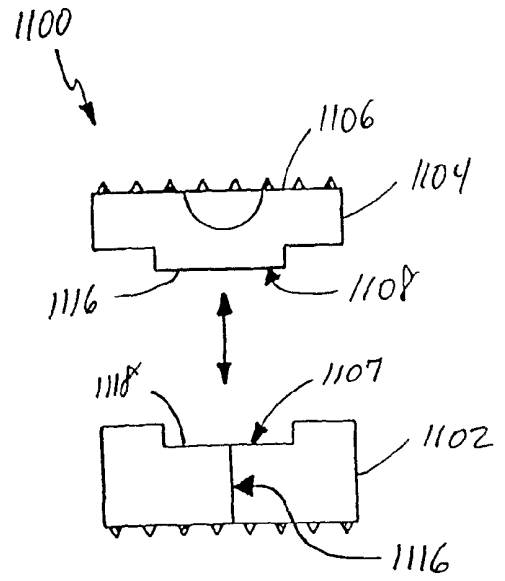

FIG. 8B

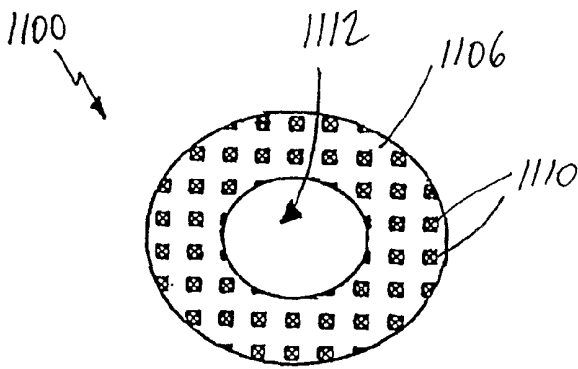

FIG. 8C

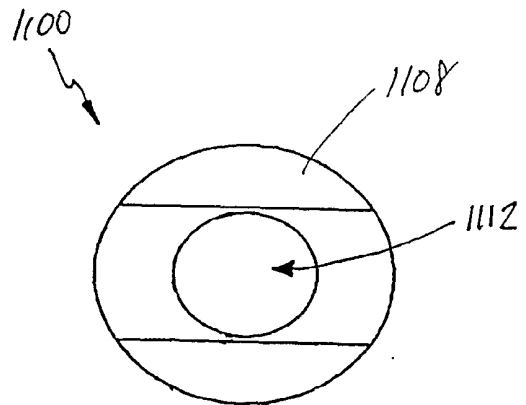

FIG. 8D

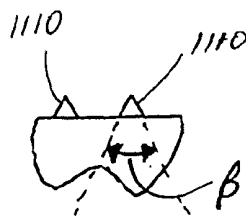

FIG. 8E

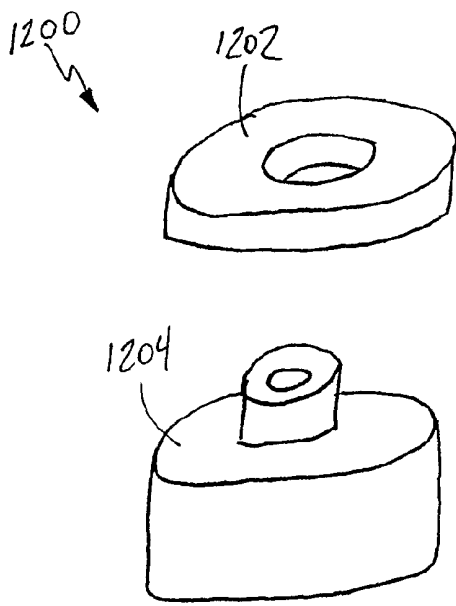

FIG. 9A

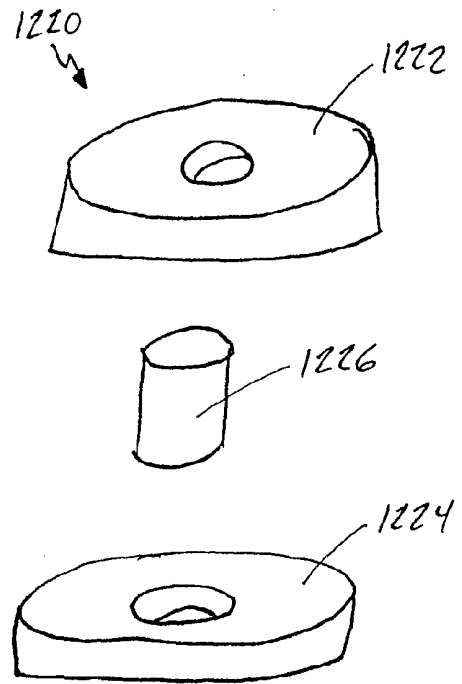

FIG. 9B

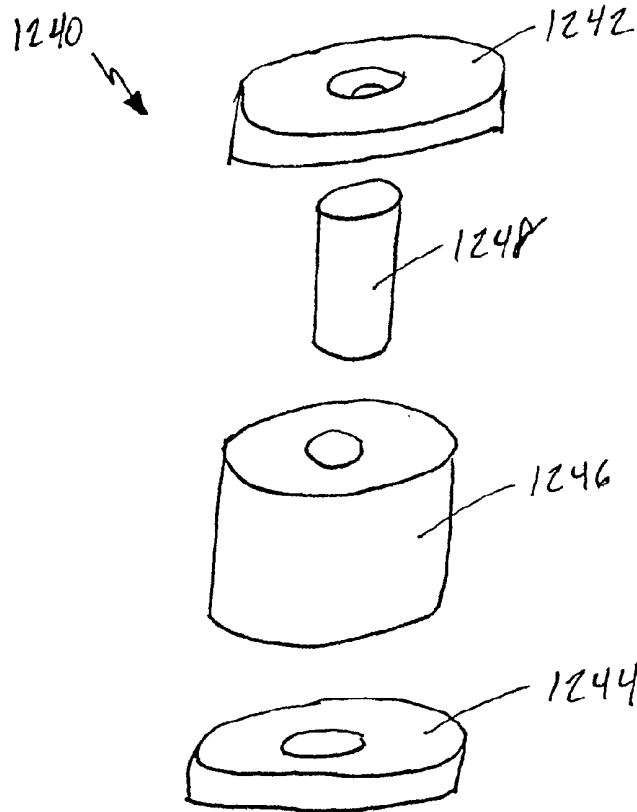

FIG. 9C

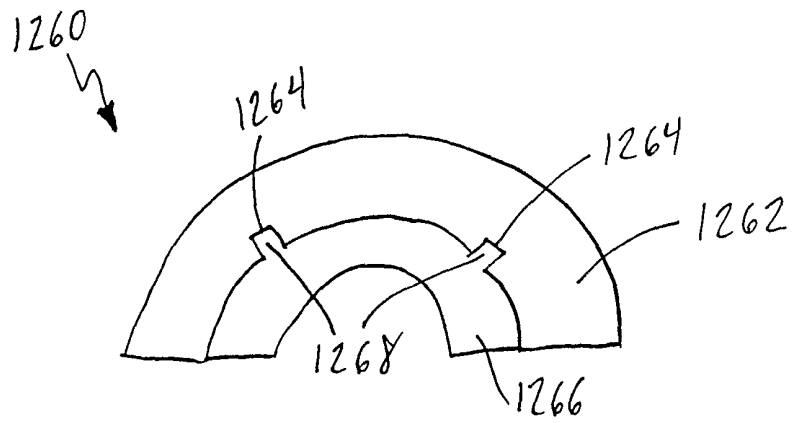

FIG. 10

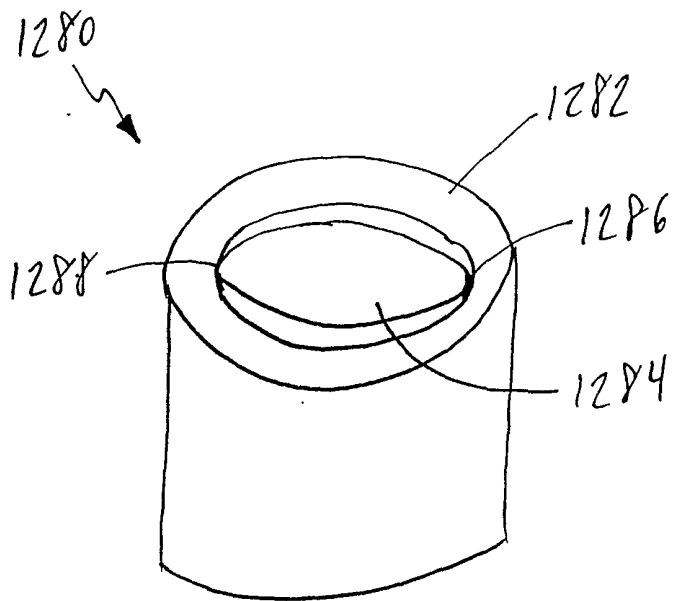

FIG. 11

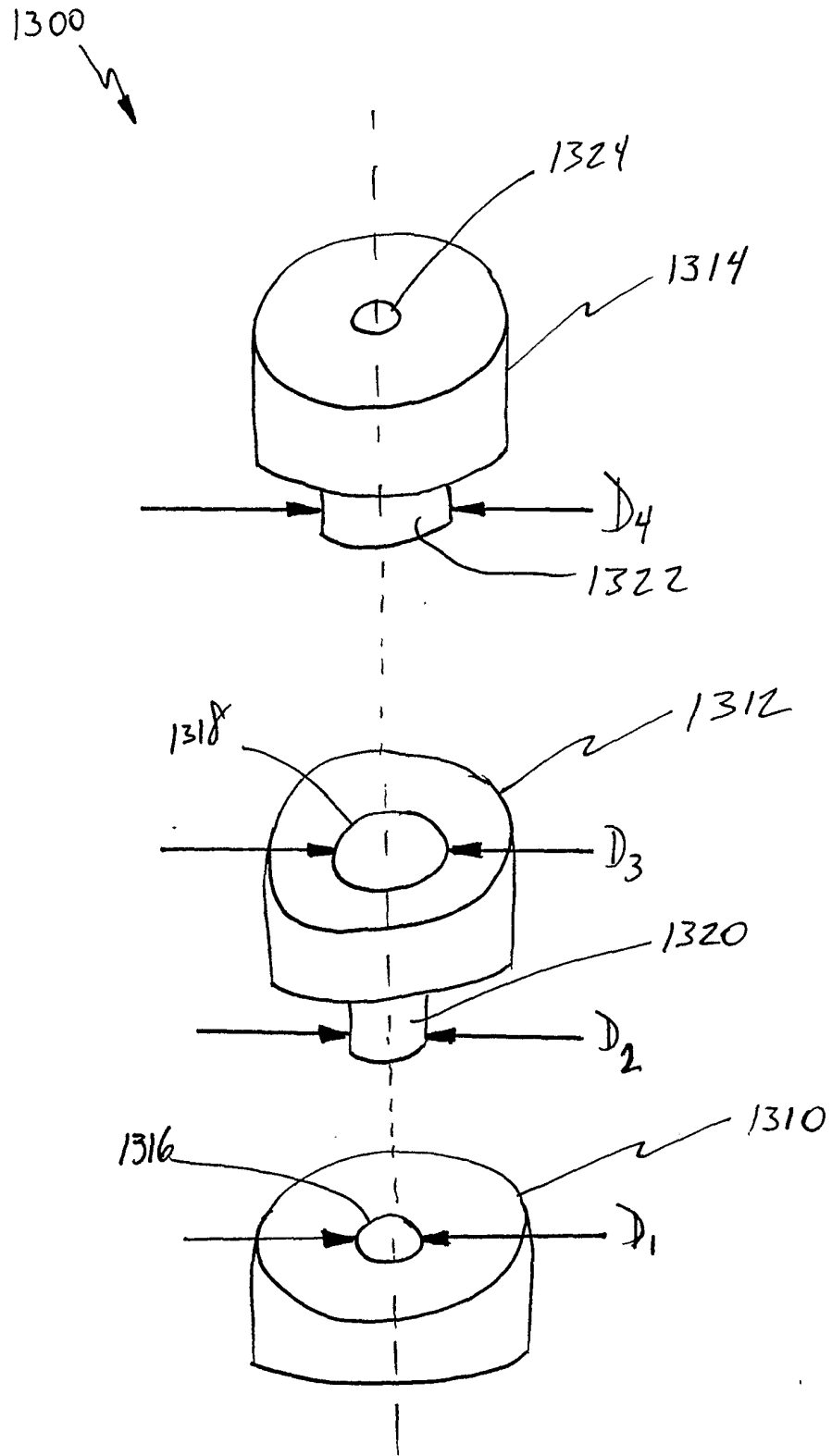

FIG. 12

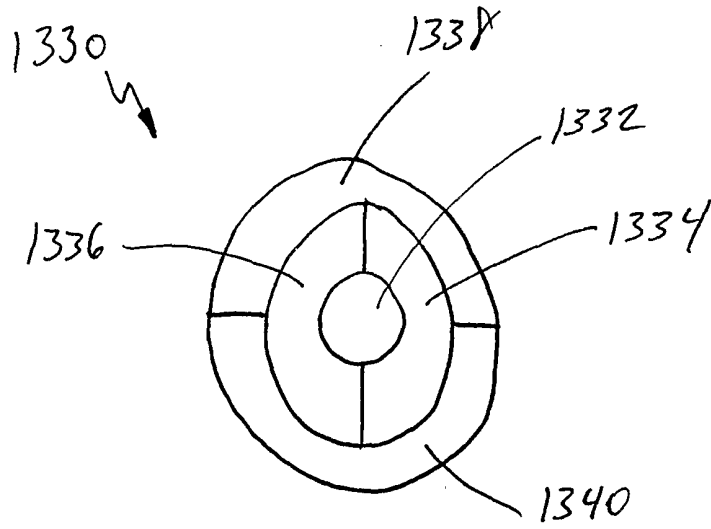

FIG. 13

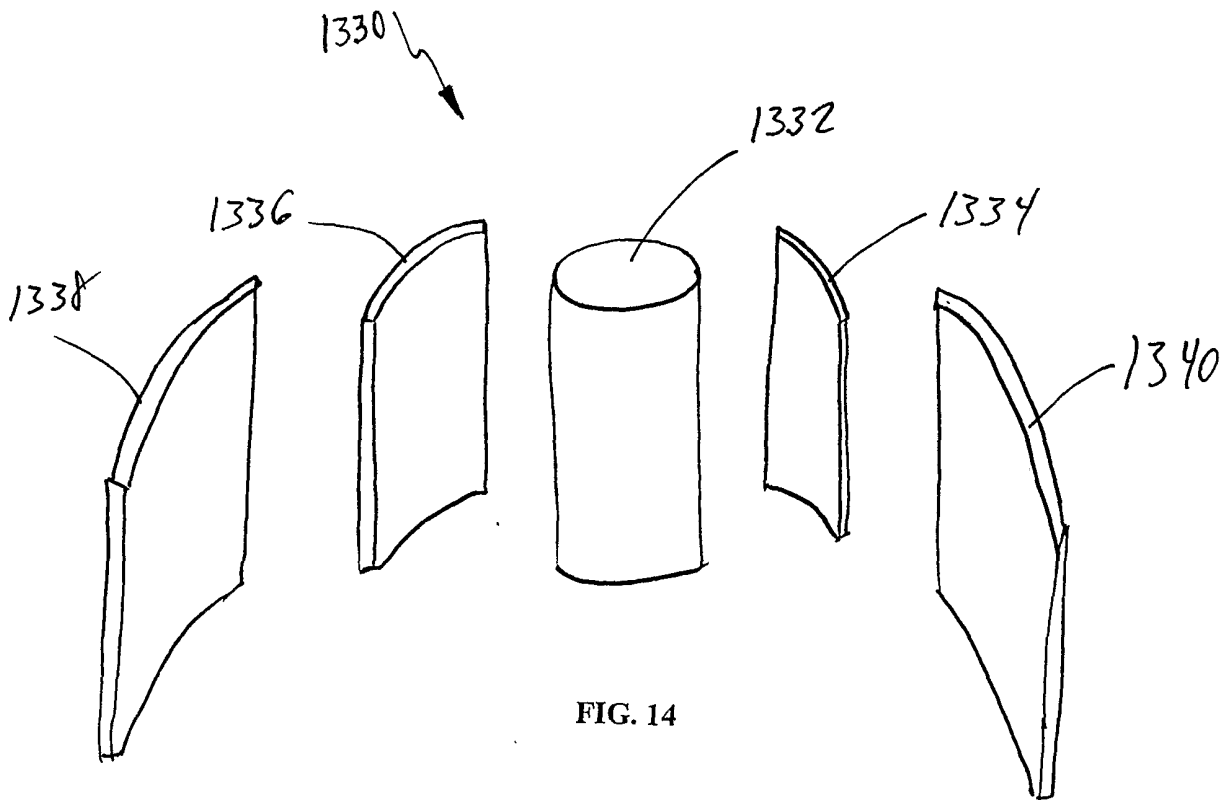

FIG. 14

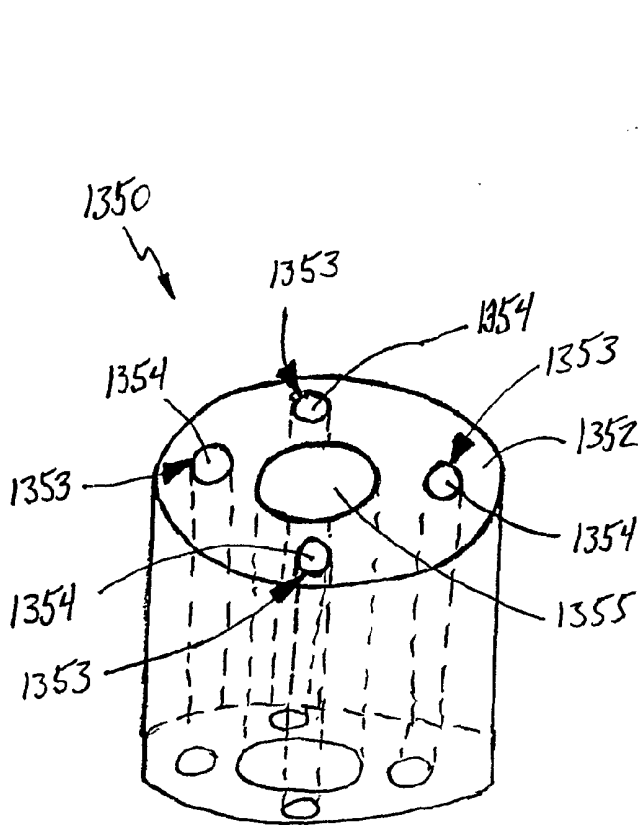

FIG. 15

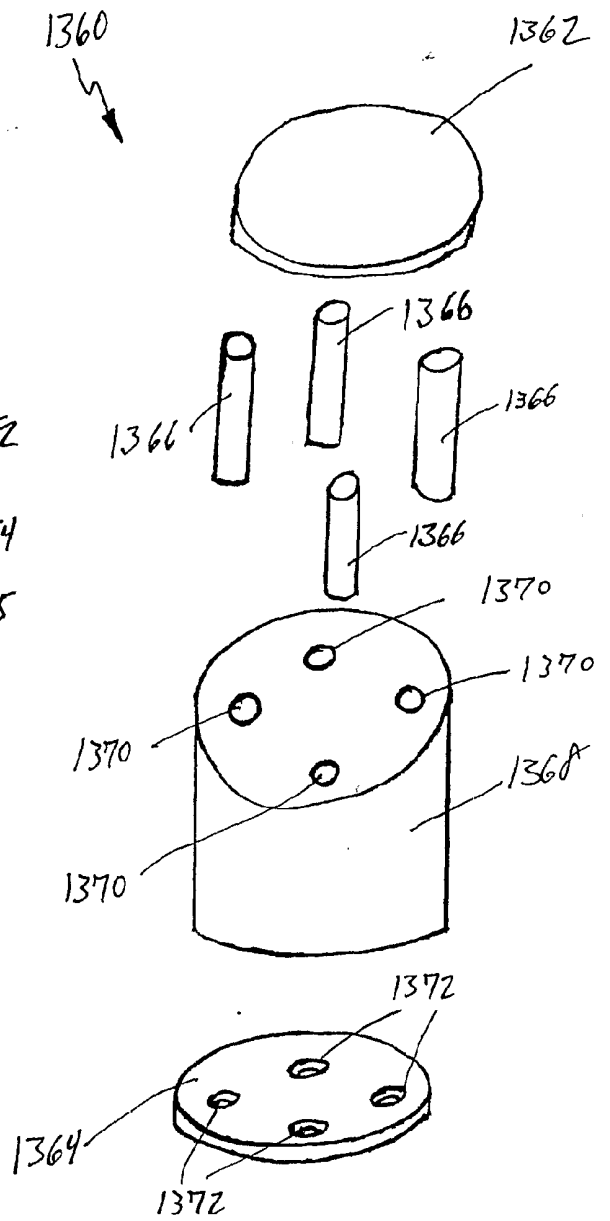

FIG. 16

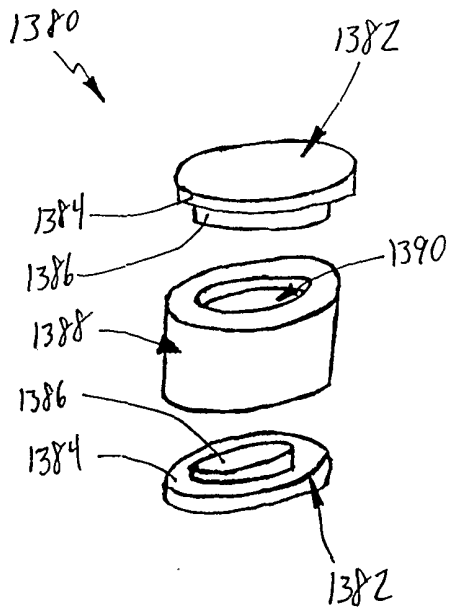

FIG. 17

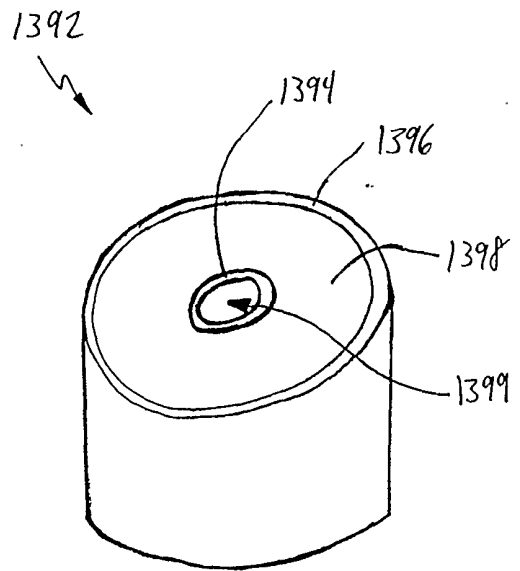

FIG. 18

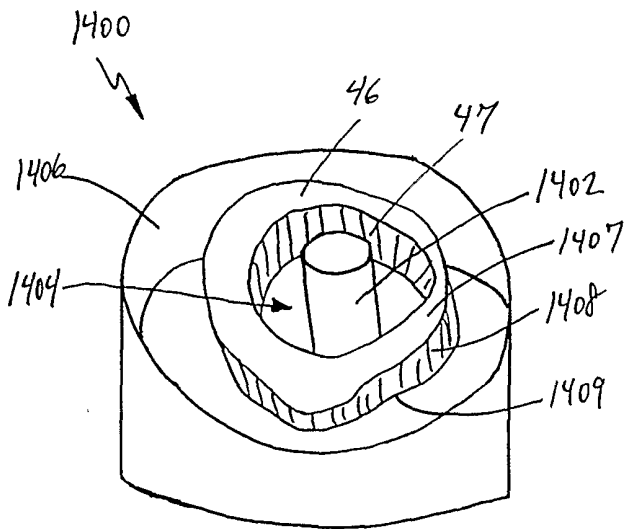

FIG. 19A

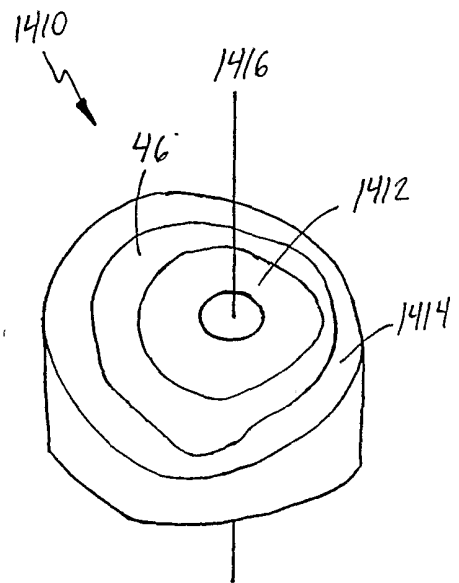

FIG. 19B