

April 19, 1927.

1,625,619

J. MARETTE

ELECTRIC LAMP FOR CINEMATOGRAPHIC APPARATUS

Filed Aug. 8, 1922

Fig. 1

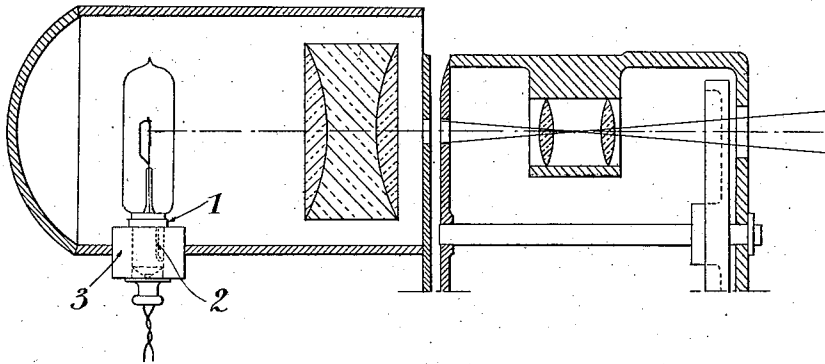

Fig. 2

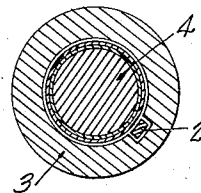
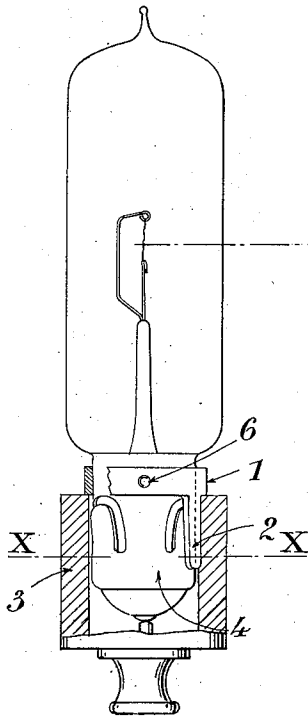

Fig. 3

Jacques Marette  
INVENTOR;

By *Otto Munk*  
his Attorney.

# UNITED STATES PATENT OFFICE.

JACQUES MARETTE, OF VINCENNES, FRANCE, ASSIGNOR TO PATHE CINEMA, ANCIENS  
ETABLISSEMENTS PATHE FRERES, OF PARIS, FRANCE.

## ELECTRIC LAMP FOR CINEMATOGRAPHIC APPARATUS.

Application filed August 8, 1922, Serial No. 580,507, and in France December 5, 1921.

This invention has for its object an improvement in electric lamps for cinematographic apparatus and other projection apparatus, particularly for those which are intended to be manipulated by a public of amateurs, this improvement permitting to obtain an exact position in height and in orientation of the filament of the lamp with reference to the optical system of the apparatus, lenses and mirror or analogous system, with a view of working in the best conditions of luminous efficiency without having to carry out a precise adjustment, for example by projecting the filament upon the projection screen, which operation is difficult especially for the public which is generally inexperienced.

According to the invention, the fitting of the lamp is provided with a ring or like part adapted to rest upon the lamp socket and placed in such a position as to ensure the correct position of the lamp filament as to height, said ring being provided with a lug, tongue or like member adapted to enter a corresponding recess in the socket and occupying a determined position for ensuring the proper angular position of the filament.

Inasmuch as the socket which will receive the lamp in the projection apparatus has a fixed position suitably determined with reference to the optical elements of the apparatus, and since each ring is secured at the factory upon the fitting of each lamp exactly in the desired position and the lug or projection is located on the ring in the exact position desired, with respect to the filament of said lamp, it will be understood that it is thus possible to sell to the public lamps which will be interchangeable and it will be sufficient to place into the lamp socket of the apparatus any lamp constructed in accordance with the invention and the filament of said lamp will immediately occupy the position required without any previous adjustment, said filament being immediately in alignment with the optical axis, at the desired height and in the proper position as concerns its lateral angular position.

In the accompanying drawing given by way of example:

Fig. 1 is a diagrammatical view of a pro-

jection apparatus with the improved lamp according to the invention.

Fig. 2 is a view on a large scale of the lamp in its socket.

Fig. 3 is the section of the socket according to X—X.

According to the form of construction represented, one secures to the base or fitting of the lamp a split ring 1 provided with a tenon, lug or projection 2. This ring can be secured to the base 4 by means of a screw 6 or a soldered place or by any other means. The base is engaged in the ordinary way in the socket 3 of the lamp holder which is provided with a vertical slot into which the tenon 2 enters. The position to be occupied by the split ring provided with its tenon is determined by a previous adjustment made at the factory. It is thus seen that in order to put the lamp in place in the socket, it is required to turn it so that the tenon shall engage in the slot, which will have the effect of turning the filament, about in the proper direction. By then pushing the lamp base into its socket, the lower edge of the ring will make contact with the upper edge of the socket, whereby the adjustment of the filament as to height will be made. On the other hand, the socket 3 occupies the desired position in its carrier so that its filament is in alignment with the optical system.

Any unskilled person is thus certain to properly place the filament of the lamp with reference, for instance, to the system of lenses and mirror of a projection lantern.

The present invention is of course not limited to the dispositions indicated by way of example in the drawing. In particular, the ring can be split or not. It can be made of any kind of material; the tenon can be integral therewith or be attached to the same or can be made of a different material. The method of attaching the ring to the lamp base may be absolutely of any kind. The form of the tenon is not limited to the one shown in the drawing; the device can be applied to all types of electric lamps.

Having now described my invention, what I claim as new and desire to secure by Letters Patent is:

A lighting device for projection apparatus

comprising an ordinary glow-lamp, a ring secured to the cap of said lamp and adapted to rest with its lower edge on the upper edge of the lamp-socket for ensuring automatically the exact position in height of the lamp filament and a lug secured on said ring extending longitudinally on said cap towards the lower part of said cap and adapted to engage into a recess provided in said lamp-socket for ensuring automatically the exact angular position of said filament. 10

In testimony whereof I have signed my name to this specification.

JACQUES MARETTE.