



(72) GHORI, Amar, US

(72) WHITE, John, US

(71) SHAREWAVE, INC., US

(51) Int.Cl.⁶ H04L 12/28, H04L 12/40

(30) 1997/01/31 (08/792,361) US

(54) **PROCEDE ET APPAREIL PERMETTANT D'INCORPORER UN
EQUIPEMENT DANS UN SYSTEME INFORMATIQUE**

(54) **A METHOD AND APPARATUS FOR INCORPORATING AN
APPLIANCE UNIT INTO A COMPUTER SYSTEM**

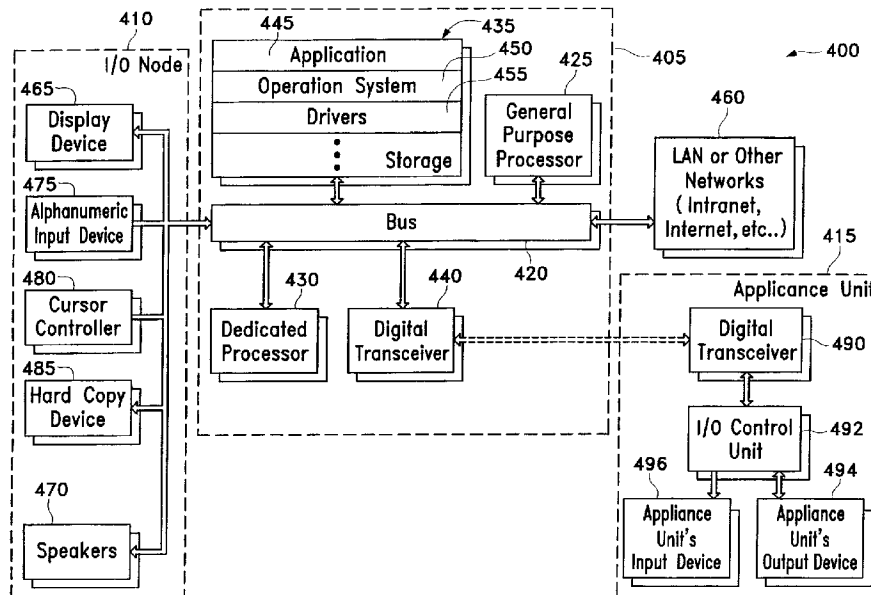

(57) L'invention concerne un procédé et un appareil permettant d'incorporer un équipement dans un système informatique. Un mode de réalisation de l'invention prévoit un ordinateur pourvu d'un premier émetteur-récepteur radio numérique de couplage communicant avec le premier émetteur-récepteur radio. Cet équipement comprend également (1) un dispositif de sortie, couplé de façon communicante au second émetteur-récepteur radio de manière à obtenir une présentation de sortie qui soit fonction des signaux provenant de l'ordinateur via les émetteurs-récepteurs radio, et (2) un dispositif d'entrée, couplé de façon communicante au second émetteur-récepteur radio de manière à recevoir les signaux en provenance d'un opérateur de l'équipement.

(57) The invention provides a method and apparatus for incorporating an appliance into a computer system. One embodiment of the invention has a computer with a first digital wireless transceiver, and an appliance unit with a second digital wireless transceiver for communicatively coupling to the first wireless transceiver. This appliance unit also has (1) an output device, communicatively coupled to the second wireless transceiver, for presenting an output presentation based on signals received from the computer via the wireless transceivers, and (2) an input device, communicatively coupled to the second wireless transceiver, for receiving input signals from an operator of the appliance unit.





INTERNATIONAL APPLICATION PUBLISHED UNDER THE PATENT COOPERATION TREATY (PCT)

(51) International Patent Classification ⁶ : H04L 12/28, H04N 5/445	A1	(11) International Publication Number: WO 98/34378 (43) International Publication Date: 6 August 1998 (06.08.98)
<p>(21) International Application Number: PCT/US98/01820</p> <p>(22) International Filing Date: 30 January 1998 (30.01.98)</p> <p>(30) Priority Data: 08/792,361 31 January 1997 (31.01.97) US</p> <p>(71) Applicant (for all designated States except US): SHARE-WAVE, INC. [US/US]; 5175 Hillside Circle, El Dorado Hills, CA 95762 (US).</p> <p>(72) Inventors; and (75) Inventors/Applicants (for US only): GHORI, Amar [US/US]; 3229 Kensington Drive, El Dorado Hills, CA 95762 (US). WHITE, John [US/US]; 3299 Cessna Drive, Cameron Park, CA 95682 (US).</p> <p>(74) Agent: LIU, Wen; Morrison & Foerster LLP, 755 Page Mill Road, Palo Alto, CA 94304-1018 (US).</p>	<p>(81) Designated States: AL, AM, AT, AU, AZ, BA, BB, BG, BR, BY, CA, CH, CN, CU, CZ, DE, DK, EE, ES, FI, GB, GE, GH, GM, GW, HU, ID, IL, IS, JP, KE, KG, KP, KR, KZ, LC, LK, LR, LS, LT, LU, LV, MD, MG, MK, MN, MW, MX, NO, NZ, PL, PT, RO, RU, SD, SE, SG, SI, SK, SL, TJ, TM, TR, TT, UA, UG, US, UZ, VN, YU, ZW, ARIPO patent (GH, GM, KE, LS, MW, SD, SZ, UG, ZW), Eurasian patent (AM, AZ, BY, KG, KZ, MD, RU, TJ, TM), European patent (AT, BE, CH, DE, DK, ES, FI, FR, GB, GR, IE, IT, LU, MC, NL, PT, SE), OAPI patent (BF, BJ, CF, CG, CI, CM, GA, GN, ML, MR, NE, SN, TD, TG).</p> <p>Published With international search report. Before the expiration of the time limit for amending the claims and to be republished in the event of the receipt of amendments.</p>	

(54) Title: A METHOD AND APPARATUS FOR INCORPORATING AN APPLIANCE UNIT INTO A COMPUTER SYSTEM

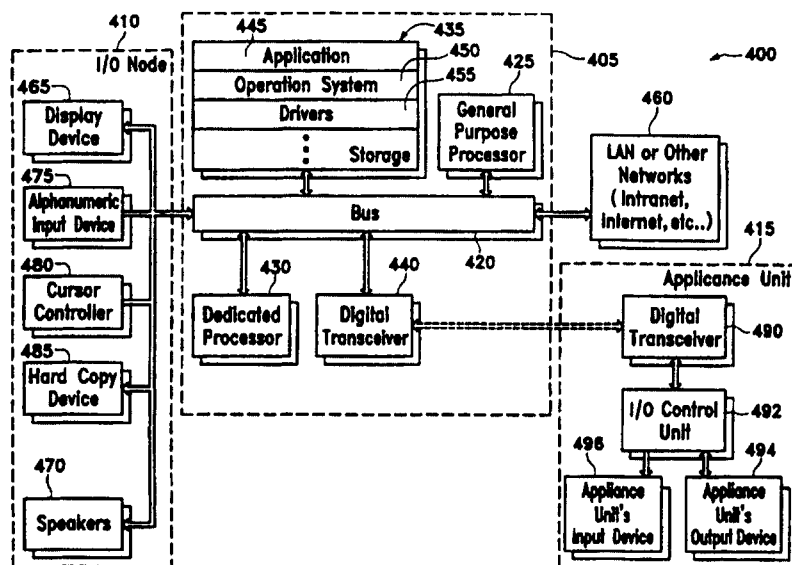

(57) Abstract

The invention provides a method and apparatus for incorporating an appliance into a computer system. One embodiment of the invention has a computer with a first digital wireless transceiver, and an appliance unit with a second digital wireless transceiver for communicatively coupling to the first wireless transceiver. This appliance unit also has (1) an output device, communicatively coupled to the second wireless transceiver, for presenting an output presentation based on signals received from the computer via the wireless transceivers, and (2) an input device, communicatively coupled to the second wireless transceiver, for receiving input signals from an operator of the appliance unit.

**A METHOD AND APPARATUS FOR INCORPORATING AN
APPLIANCE UNIT INTO A COMPUTER SYSTEM**

BACKGROUND OF THE INVENTION

In the past several years, there has been some discussion regarding Smart Homes, in which computers are connected to appliances to control the operation of appliances. For example, these computers are typically said to turn on/off these appliances and to control their operational settings. These systems do not incorporate appliances into the computer system by allowing the appliance to serve as an input/output ("I/O") interface of the computer. Also, these systems are typically said to couple the computers and the appliances through wired communication links. Such wired communication links are disadvantageous as they are difficult and costly to install.

Figures 1 and 2 present recent prior art systems that couple a computer to a television ("TV") or a video cassette recorder ("VCR") through a scan or television converter. These converters couple to the TV or VCR through a wired or wireless link. However, these systems differ in that system 100 only utilizes processor 115 to generate RGB data for display, while system 200 utilizes a dedicated graphics accelerator 215 to generate the display data.

As shown in these figures, these prior systems typically include a display device 140 and a computer 105, which includes a bus 110, a processor 115, and a storage 120. Bus 110 connects the various internal modules of the computer. For instance, bus 110 couples processor 115 and storage 120. The storage hardware stores data, such as (1) an application program 125 for performing certain tasks, (2) an operating system 130 for

controlling the allocation and usage of the computer's hardware and software resources, and (3) I/O drivers 135 for providing the instruction set necessary to control I/O devices, such as display device 140.

Through bus 110, processor 115 retrieves the data stored in storage 120. The processor then processes the data. At times, the results of this processing is displayed on display device 140, which also couples to bus 110. This display device is typically a PC monitor, such as a cathode ray tube (CRT), for displaying information to a computer user. Other prior art systems utilize a liquid crystal display (LCD) for their display device.

Both display devices 140 of **Figures 1 and 2** receive the display RGB data from Y-tap connectors or similar pass-through devices (not shown). Also, in both these systems, a digital-to-analog converter (a DAC, which is not shown) converts digital RGB signals to analog RGB signals for display on display devices 140. This DAC can be a part of computer 105, add-in card 210, display device 140, or converters 145.

The Y-tap connector also supplies the RGB data to converters 145, which convert the received signals to analog NTSC or PAL signals supplied to the television or the VCR. Depending on the location of the DACs, these converters can be either scan converters or TV converters. Specifically, if computer 105 or graphics engine 215 contain a DAC, and therefore supply analog RGB data to converter 145, then the converters are scan converters for converting analog RGB data to NTSC or PAL encoded signals. On the other hand, when display device 140 and converter 145 contain the DACs, the converters are TV converters for converting digital RGB data to digital YCrCb data, which are then encoded to NTSC or PAL encoded signals.

Some prior art systems utilize analog wireless links to connect a converter (such as converters 145) to a TV. These analog wireless links are typically radio frequency ("RF") links operating at the 900 MHz frequency range. Also, one prior art system establishes a bi-directional link between the converter and the television. The downstream link used by this prior art system (i.e., the link for forwarding communications from the computer to the television) is also an analog RF link.

There are a number of disadvantages associated with the use of analog RF links. For instance, a receiver receives a degraded signal through such a link because the received signal is composed of a number of signals that correspond to the same transmitted signal but reach the receiver through a variety of paths. In other words, such a link does not offer protection against signal degradation due to the multi-path phenomena.

In addition, such communication links are susceptible to intra-cell interference from noise generated in the communication cell formed around the periphery of the computer and the television. Intra-cell interfering noise can be generated by other appliances or by normal household activity. The intra-cell interfering noise, in turn, can deteriorate the quality of the transmitted data, and thereby deteriorate the quality of the TV presentation.

Analog communication links also are susceptible to inter-cell interference. Such interference can be noise interference from noise sources outside of the communication cell formed by the computer and the television. For instance, such interfering noise can be attributable to RF communications from communication cells (perhaps formed by other computers and televisions) adjacent to the cell formed by the computer and the television.

These inter-cell interfering noises can further deteriorate the quality of the transmitted data and the presentation.

Inter-cell interference also refers to eavesdropping on the communications from the computer to the television. The analog communication link between the computer and the television is typically not a secure communication link, because securing such a link is often difficult. Therefore, an eavesdropper outside of the communication cell can tap into the signals transmitted from the computer to the television.

Figure 3 presents the general operational flow 300 of the prior art systems 100 and 200. As shown in this figure, a graphics command is first generated by an application program 305. This command is then passed to the graphics engine 320 (i.e., processor 115 or graphics engine 215) via the operating system and the display driver. In turn, based on the received graphics command, the graphics engine 320 generates RGB data. This RGB data is then routed to PC monitor 140 for display. The converter 325 also receives the RGB data and converts it into analog NTSC or PAL signal supplied to the television or the VCR.

Thus, as set forth in **Figure 3**, these prior art systems (1) intercept the RGB signals prepared for display on monitor 140, and then (2) convert this RGB data to analog NTSC or PAL encoded data for a TV display. Because the signals forwarded to the television or the VCR are tapped at such an advanced operational stage, these systems have a number of disadvantages.

For instance, the quality of their TV presentation suffers, because the TV images are generated based on RGB data composed for the PC monitor. In other words, the

WO 98/34378

PCT/US98/01820

quality of the display deteriorates once it has to be remapped for analog NTSC after being composed for PC monitor. This remapping is also disadvantageous because it is inefficient and computationally expensive. Numerous calculations that are performed downstream from the drivers to compose the RGB data for the PC monitor have to be recalculated to obtain the graphical images for the television or the VCR.

Consequently, there is a need in the art for a method and apparatus for incorporating an appliance into a computer system. There is also a need for a wireless computer system which uses superior digital wireless communication links. In addition, a computer system is needed which composes output presentations based on the type of the output devices.

SUMMARY OF THE INVENTION

The present invention provides a method and apparatus for incorporating an appliance into a computer system. One embodiment of the invention includes a computer and an appliance unit communicatively coupled to the computer through a digital wireless link. The appliance unit includes an output device with a display screen for displaying presentations based on signals transmitted from the computer to the device through the link. In one embodiment of the invention, the output device is a television. One such embodiment communicatively couples the appliance unit and the computer through a spread spectrum link.

Still another embodiment of the invention has a computer with a first digital wireless transceiver, and an appliance unit with a second digital wireless transceiver for communicatively coupling to the first wireless transceiver. This appliance unit also has (1)

an output device, communicatively coupled to the second wireless transceiver, for presenting an output presentation based on signals received from the computer via the wireless transceivers, and (2) an input device, communicatively coupled to the second wireless transceiver, for receiving input signals from a operator of the appliance unit.

BRIEF DESCRIPTION OF THE DRAWINGS

The novel features of the invention are set forth in the appended claims. However, for purpose of explanation, several embodiments of the invention are set forth in the following figures.

Figure 1 presents one prior art system for coupling a computer to a television or a VCR.

Figure 2 presents another prior art system for coupling a computer to a television or a VCR.

Figure 3 presents the general operational flow of the prior art system of **Figures 1 and 2**.

Figure 4 presents one embodiment of the computer system of the invention.

Figure 5 presents another embodiment of the computer system of the invention.

Figure 6 presents yet another embodiment of the computer system of the invention.

Figure 7 presents one embodiment of an ASIC of the computer system of **Figure 6**.

Figure 8 presents one embodiment of the I/O control unit of one embodiment of the invention.

Figure 9 presents one embodiment of an ASIC of **Figure 8**.

Figure 10 presents one embodiment of a digital transceiver of the invention.

Figure 11 presents a flow chart of the software of one embodiment of the invention.

Figure 12 presents a general operational flow for one embodiment of the invention.

Figure 13 sets forth the software architecture of one embodiment of the invention.

DETAILED DESCRIPTION OF THE INVENTION

The invention provides a method and apparatus for incorporating an appliance into a computer system. In the following description, numerous details are set forth for purpose of explanation. However, one of ordinary skill in the art would realize that the invention may be practiced without the use of these specific details. In other instances, well-known structures and devices are shown in block diagram form in order not to obscure the description of the invention with unnecessary detail.

For purposes of this application, a computer is a general-purpose machine that processes data according to a set of instructions stored internally either temporarily or permanently. An important feature of a computer is its ability to store its own instructions, which allows it to perform many operations without the need for a person or another

WO 98/34378

PCT/US98/01820

device. In other words, it is a general purpose machine that can store a variety of instructions, and therefore can perform a variety of tasks. Typically, a computer is programmable to perform a number of tasks; such a computer takes its purpose from its programming. Examples of a computer include a network computer, a personal computer (such as an Intel® based computer), a workstation (such as a SPARC®, ULTRA-SPARC®, MIPS®, or HP® station), etc.

A peripheral device is a hardware device that performs one or more primary tasks and a number of ancillary tasks related to the primary tasks. This device connects to a computer to perform any of its primary tasks and typically any of its ancillary tasks. It cannot achieve its primary purpose or function without connecting to the computer. In other words, the device is not designed to have any utilitarian purpose when it is not used with computer, and therefore has to connect to a computer before it can perform any of its function. Examples of peripherals include terminals, tape or disk drives, printers, monitors, keyboards, plotters, graphics tablets, scanners, joy sticks, paddles, cursor controllers, modems, credit card readers, bar code readers, X-terminals, dumb terminals, headsets.

An appliance, on the other hand, is a fixed function device. It can perform a few (finite set) primary, independent tasks, and a number of ancillary tasks related to these independent unrelated tasks. Unlike a peripheral, it has been specifically designed to have a utilitarian purpose even when it does not connect to a computer. Thus, it can perform at least one of its primary tasks without the assistance of a computer. Unlike computer, it cannot perform an infinite number of unrelated tasks because it cannot be programmed with an infinite number of unrelated instruction sets for performing an infinite number of

unrelated tasks. Examples include audio-visual equipment (such as televisions, cameras, VCRs, telephones), utility appliances, kitchen appliances (such as refrigerators, microwaves), etc.

A number of embodiment of the invention include a computer and a remote appliance unit (i.e., a remote appliance node) communicatively coupled to the computer through a digital wireless link. The appliance unit includes an appliance. Also, in several embodiments of the invention, the appliance includes an output device for presenting an output presentation to a user, an input device for receiving commands from the user, and I/O control logic for communicatively coupling the output and input devices to a digital wireless transceiver.

In certain embodiments of the invention, an appliance serves as the output device and/or input device. One such embodiment includes a television as the output device, a wireless keyboard as the input device, and a settop box as the I/O control logic. One example of the settop box includes a digital wireless transceiver which communicates with a digital wireless transceiver of the computer, and thereby communicatively couples the appliance unit to the computer.

Figure 4 sets forth one embodiment of a computer system of the invention. Computer system 400 includes a computer 405, a local computer input/output ("I/O") node 410, and an appliance 415. Computer 405 can be a network computer, a personal computer (such as an Intel® based computer), a workstation (such as a SPARC®, ULTRA-SPARC®, MIPS®, or HP® station), etc.

One embodiment of this computer composes audio-visual data for presentation at the computer I/O node 410, which couples to the computer either through a hardwired connection or a wireless link. Also, in one embodiment of the invention, computer 405 composes the audio-visual data, and transmits this data via a digital wireless link to the for presentation.

In an alternative embodiment, computer 405 does not compose the audio-visual data for the , but rather transmits the audio-visual commands to the appliance unit, which composes the audio-visual data. For instance, in one such embodiment, computer 405 transmits ASCII code to the appliance unit, which then generates a displayed output text based on this transmitted code. In yet another embodiment of the invention, computer 405 transmits particular audio-visual commands (such as multi-media commands including graphics, video, and audio primitives) to the appliance unit, while also composing and transmitting audio-visual data based on other audio-visual commands.

As shown in **Figure 4**, computer 405 includes bus 420, general-purpose processor 425, dedicated processor 430, storage 435, and digital transceiver 440. Bus 420 collectively represents all of the communication lines that connect the numerous internal modules of the computer. Even though **Figure 4** does not show bus controller, one of ordinary skill in the art will appreciate one embodiment of computer 405 includes a variety of bus controllers for controlling the operation of the bus.

Bus 420 couples processors 425 and 430, which process digital data, and storage 435, which stores digital data. One embodiment of storage 435 stores application programs 445 (such as a word processing program, a multi-media game program, a computer aided design program, etc.) for performing certain types of tasks by manipulating

text, numbers, and/or graphics. Storage 435 also stores an operating system 450 (such as Windows 95® sold by Microsoft Corporation). An operating system ("OS") serves as the foundation on which application programs operate and controls the allocation and usage of hardware and software resources (such as memory, processor, storage space, peripheral devices, drivers, etc.).

Storage 435 further stores driver programs 455, which provide the instruction set necessary for operating (e.g., controlling) particular I/O devices (such as the devices at I/O node 410 or the devices of appliance unit 415). One example of the operation of the drivers, the operating system, and the application programs is described below by reference to **Figures 11-13**.

One embodiment of storage 435 includes a read and write memory (e.g., RAM). This memory stores data and program instructions for execution by processors 425 and 430, and stores temporary variables or other intermediate information during the operation of the processor. An embodiment of storage 435 also includes a read only memory (ROM) for storing static information and instructions for the processors. An embodiment of storage 435 further includes a mass data storage device, such as a magnetic or optical disk and its corresponding disk drive.

In one embodiment of the invention, the source code necessary for the operation of the invention is downloaded from mass data storage device (e.g., downloaded from a hard drive or a floppy disk) to the read/write memory during the operation of the computer. The computer then utilizes the software residing in the read/write memory to direct the operation of the processors. However, firmware instructions (i.e., the source code residing in the read-only memory) can also direct the operation of the processors.

In one embodiment of the invention, processor 425 plus instructions stored in storage 435 serve as the I/O engine for the computer I/O node 410, while dedicated processor 435 (which can be a dedicated multi-media processor) plus instructions stored in storage 435 serve as the I/O engine for appliance unit 415. In an alternative embodiment of the invention set forth in **Figure 5**, a second dedicated processor 510 is used, instead of processor 425, to form the I/O engine for the local I/O node.

In yet another embodiment of the invention, a single processor (such as dedicated processor 430 or general-purpose processor 425) serves as the I/O engine for both the I/O node and the appliance unit. Still another embodiment of the invention uses a dedicated ASIC I/O engine for some or all of the I/O functions (such as communication control, signal formatting, audio/graphics processing, compression, filtering, etc.) for either or both of the I/O node and the appliance unit. One such embodiment is described below by reference to **Figure 6**.

In different embodiments of the invention, the I/O engines of the computer perform a number of different tasks. For instance, in one embodiment, the computer's I/O engine for the appliance unit just controls the communication between the computer and the appliance unit (e.g., the I/O engine simply controls the transmission of audio-visual commands to the appliance unit, and/or the I/O engine formats the signals for transmission to the appliance unit). Another embodiment of the computer's appliance I/O engine transmits particular audio-visual commands (e.g., multi-media commands including audio primitives or graphics primitives, such as graphical, text, or video primitives) to the appliance unit, while also composing and transmitting audio-visual data based on other audio-visual commands to the appliance unit.

In another embodiment of the invention, the local node's I/O engine serves as an audio-visual processing engine and processes audio-visual instructions (from application 445, operating system 450, and/or drivers 455) for the computer I/O node 410, while the appliance unit's I/O engine serves as an audio-visual processing engine and processes audio-visual instructions (from application 445, operating system 450, and/or drivers 455) for appliance unit 415. Other embodiments of the computer's I/O engines include (1) a compression engine performing signal compression, (2) an encoding engine performing digital signal encoding, (3) a digital filtering engine performing digital filtering, and/or (4) and a frame synchronization engine performing audio-visual frame synchronization.

As shown in **Figure 4**, bus 420 also couples computer 405 to a network 460 through a network adapter (not shown). In this manner, the computer can be a part of a network of computers (such as a local area network ("LAN"), a wide area network ("WAN"), or an Intranet) or a network of networks (such as the Internet). Through this network connection, one embodiment of the computer is a network computer.

Computer 405 also communicatively couples to a local computer I/O node 410 through a hardwired connection or a wireless link. This node includes a display device 465, speakers 470, an alphanumeric input device 475, a cursor controller 480, and a hard copy device 485. The display device (such as a cathode ray tube (CRT) or a liquid crystal display (LCD)) couples to bus 420, and displays information to a computer user. Bus 420 also couples to speakers 470 which play the audio data outputted by computer 405.

Alphanumeric input device 475 (e.g., a keyboard) couples to bus 420 for allowing a user to forward information and commands to computer 405. Another user input device coupled to bus 420 is cursor controller 480. This device may take many different forms,

such as a mouse, a trackball, a stylus tablet, a touch-sensitive input device (e.g., a touchpad), etc. Another device which may be coupled to bus 420 is a hard copy device 485 for printing a hard copy on paper.

Computer 405 also communicatively couples to an appliance unit 415. As shown in **Figure 4**, the appliance unit includes I/O control unit 492, digital wireless transceiver 490, input device 496, and output device 494. An appliance unit includes an appliance, such as audio-visual equipment (such as televisions, cameras, VCRs), utility and kitchen appliances (such as refrigerators, microwaves), etc.

As mentioned above, an appliance performs a few primary, independent tasks, and a number of ancillary tasks related to these independent tasks, without connecting to the computer. Unlike a peripheral, it has been specifically designed to have a utilitarian purpose even when it does not connect to a computer. Thus, it can perform at least one of its primary tasks without the assistance of a computer.

These independent tasks of an appliance are performed by hardware which is not shown in **Figure 4** in order not to obscure the description of the invention with unnecessary detail. Hence, this figure only sets forth the circuitry necessary for incorporating an appliance into a computer system (i.e., only presents transceiver 490, control unit 492, and I/O devices 494 and 496).

This appliance unit's I/O interface couples to the software and hardware components of the computer via I/O control unit 492, digital wireless transceivers 490 and 440, and bus 420. The I/O interface of the appliance unit includes (1) input device 496 for receiving input commands from operators of the appliance unit, and (2) output device 494

WO 98/34378

PCT/US98/01820

for presenting an output presentation to viewers at this unit. Input device 496 allows a user of the appliance unit to enter input signals. Certain input signals are then forwarded to computer 405. Examples of such an input device include a keyboard, a cursor controller, a remote controller, a keypad, a joystick, or a game controller.

Output device 494, on the other hand, allows audio data and/or visual data to be presented (e.g., presented on a display screen or through speakers) to the user of the appliance unit. Particular output presentations are based on signals received from the computer via the digital wireless link. Examples of such an output device include a television, a PC monitor, an LCD screen, a speaker, etc.

Although **Figure 4** only shows one input device and one output device communicatively coupled to the computer, one of ordinary skill will realize that different embodiments of the appliance unit do not include any input or output devices, or include additional input and output devices. Also, different embodiments of the appliance unit do not communicatively couple the input device to the computer, or do not communicatively couple output device to the computer.

The input and output devices 496 and 494 couple to computer 405 via transceiver 490 and I/O control unit 492 of the appliance unit. Transceiver 490 is a digital wireless communication device for communicating on a wireless channel to the computer's digital transceiver 440. In one embodiment of the invention, transceivers 440 and 490 are spread spectrum transceivers.

Spread spectrum transceivers utilize spread spectrum modulation to modulate signals. Spread spectrum modulation spreads a relatively narrow band of transmitted

frequencies over a broad band (which, for example, can be ten times as wide as the narrow band) with lower energy content to minimize noise and interference.

More specifically, spread spectrum transceivers utilize a form of radio transmission in which the signal is distributed over a broad frequency range. This distribution pattern is based on either direct sequence coding or frequency hopping. In direct sequence coding, the information to be transmitted is modified by a multi-bit binary chipping code, which spreads the signal out over a broader frequency range. Only the receiver knows the code, and thus only it can decode the received signal. Alternatively, in frequency hopping, a transmitter transmits at a particular frequency for a short time interval, then switches to another frequency for another short interval, and so on. Only the receiver knows the random frequency selection sequencing.

Furthermore, one embodiment of transceivers 440 and 490 communicate through an isochronous (i.e., time sensitive) link. The operation of an isochronous communication link is dependent on constant time intervals. Such a connection assures that there always is an integral number of time intervals between any two transmission, whether synchronous or asynchronous. This type of transmission capability is beneficial for transmitting video and audio signals in real time. Thus, one embodiment of transceivers 440 and 490 are spread spectrum transceivers that communicate through an isochronous link.

The I/O control unit serves as an interface unit between the appliance unit's I/O devices and its transceiver. This control unit is either (1) a programmable computer or a control logic circuit of the appliance or the transceiver, or (2) an application specific integrated circuit coupled to the appliance.

I/O control unit 492 couples to transceiver 490 to receive information supplied from the computer via transceiver 440. The control unit transforms the received information to a format capable of presentation at the appliance unit, and then supplies this data to this unit's output device (e.g., to a television, a monitor, a speaker, etc.) for presentation to a user.

For instance, when computer 405 composes the audio-visual data and transmits an encoded (e.g., MPEG encoded) stream of audio-visual data to the appliance unit, one embodiment of the I/O control unit samples and decodes the received encoded data stream to extract the composed audio-visual data. For the embodiment having a computer that transmits audio-visual commands to appliance unit 415, I/O control unit 492 samples the received signal to extract the commands and composes audio-visual data based on the extracted commands. In yet other embodiments which have a computer that transmits particular audio-visual commands as well as audio-visual data based on other audio-visual commands, the I/O control unit extracts the commands and composes additional audio-visual data based on the extracted commands.

The control unit then supplies the composed audio-visual data to this unit's output device for presentation. Prior to supplying the data to the output device, one embodiment of the I/O control unit also encodes the extracted audio-visual data in a unique format for presentations at output device (e.g., an NTSC or PAL format for a television presentation).

I/O control unit 492 also couples to input device 496 to receive input data from the user of this unit's I/O unit. This coupling can be through a wireless channel (such as an infrared or radio-frequency, digital or analog channel) or a wired channel. The control unit then forwards this data to the computer via transceivers 490 and 440. The computer then

decodes the communication and extracts the data from the decoded communication. The computer then processes the data and, if needed, responds to the appliance unit. For instance, after extracting the input data, the computer might call up an application program, which then instructs the processor to process the input data, and, if needed, to respond to the appliance unit.

In this manner, computer system 400 allows a user to interact with a computer 405 from a remote appliance node. From this remote node, the user can access a program run on the computer, control the operation of the computer, and/or control the operation of a device coupled to the computer (such as another computer, a computer network, a peripheral, or an appliance). The user can also receive output presentations at the remote I/O unit from the computer. Some embodiments of the appliance unit are stationary, while others are not. One portable appliance unit includes a portable I/O control unit and a portable output device.

One of ordinary skill in the art would appreciate that any or all of the components of computer system 400 may be used in conjunction with the invention, and that alternative system configurations may be used in conjunction with the invention. For instance, alternative embodiments of the invention do not include a local I/O node, and/or do not connect to a network 460. Also, although **Figure 4** sets forth an appliance unit with a separate I/O control unit 492, transceiver 490, output device 494, and input device 496, one of ordinary skill in the art would appreciate that alternative embodiments of the invention have the I/O control unit and/or the transceiver as part of the circuitry of this unit's input and/or output devices.

Figure 6 sets forth a block diagram of another embodiment of the invention's computer system. This computer system uses a dedicated I/O processing engine for processing some or all of the I/O functions (such as audio/graphics processing, compression, filtering, etc.) for the appliance unit.

This dedicated engine is formed on an add-in card 615, which plugs into a PCI-connection socket of the computer and thereby couples to the computer's PCI bus to communicate to the computer's resources (e.g., its processor). This system includes a digital transceiver 635, an application specific integrated circuit (ASIC) 620, a random access memory 625, and a read-only memory 630.

Through an antenna, digital transceiver 635 transmits and receives data to and from the digital transceiver of the appliance unit. One embodiment of this digital transceiver is a spread spectrum radio transceiver and is provided in the Prism® chipset from Harris Corporation. Other vendors who provide digital spread spectrum transceivers are Hewlett-Packard, AMI, Motorola.

Other embodiments of this transceiver includes digital PCS or digital cellular transceivers. A number of embodiments of the invention use digital transceivers which encrypt their signals to protect against eavesdroppers. In addition, a number of embodiments of the invention perform error coding and decoding on the transmitted and received signals in order to guard against errors due to transmission noise.

Transceiver 635 couples to ASIC 620 through a bi-directional link for transmitting data, address, and control signals. Through this bi-directional coupling, ASIC 620

WO 98/34378

PCT/US98/01820

communicates with the processor of digital transceiver 635 to transmit and receive data to and from the appliance unit.

ASIC 620 serves as an interface between the I/O drivers and the appliance unit. Several embodiments of this ASIC compose audio-visual data from high-level audio and graphical commands, and forward (via transceiver 635) the composed digital data to their appliance units for presentation. In particular, a number of embodiments of ASIC 620 compose graphical data based on the type of output device of the appliance unit.

For instance, one such embodiment composes graphical data in a YCrCb display format, which is advantageous when the remote output device is a television. Other embodiments of ASIC 620 use other digital graphic formats, such as RGB, YUV, cmyk, etc., to represent the color space. A number of embodiments of ASIC 620 also compress and encode the audio-visual data prior to transmission to their appliance units.

ASIC 620 also couples to RAM 625, which it uses as a composition buffer for storing audio-visual information for presentation, and as a scratch memory for other functions of the ASIC. For instance, when the application program forwards instructions to the ASIC for display, one embodiment of the ASIC composes a frame, compresses it, and then stores it in the RAM.

In this manner, the ASIC uses the RAMs as an intermediate storage for storing compressed frames prior to transmission to the appliance unit. Once the ASIC is ready to transmit the compressed data, the ASIC retrieves the compressed data from the RAM and forwards it to the digital transceiver for transmission to the appliance unit. ASIC 620 also couples to ROM 630. This memory stores the firmware instructions necessary for the

operation of the ASIC. In addition, this memory can store look-up tables used by the ASIC in performing its compression and digital filtering functions.

Figure 7 sets forth one embodiment of ASIC 620 of **Figure 6**. As shown in this figure, ASIC 700 includes a peripheral component interconnect ("PCI") bridge 705, data and control buffers 710, a graphics engine 715, an audio engine 720, a compression engine 725, a frame preparation engine 730, a media access controller ("MAC") 735, and a memory controller 740.

The PCI bridge provides an interface between the ASIC and the PCI bus. For instance, the PCI bridge provides PCI-compatible signaling for the card. The PCI bridge couples to a number of internal buffers 710 which temporarily store data and commands. One of these buffers is wireless buffer 710c, which receives commands for controlling the MAC. The PCI bridge also couples to a control buffer 710d, which serves as a temporary storage location for control commands controlling the compression and frame preparation engines. These control commands include reset commands, as well as other control commands and configuration information (such as commands for setting compression ratio, the image size, and the frame rate).

PCI bridge 705 also couples to graphics buffer 710a. This buffer temporarily stores high level graphics data and commands (such as line draw commands), transmitted from the application driver. The graphics engine 715 retrieves the stored data and commands from buffer 710a to compose graphic frames.

One embodiment of graphics engine 715 composes graphical data in a YCrCb display format from graphical primitives. Such a display format is advantageous when the

WO 98/34378

PCT/US98/01820

appliance unit's output device is a television. Other embodiments of the graphics engine use other digital graphic formats, such as RGB, YUV, cmyk, etc., to represent the color space. After performing its operations, the graphics engine stores the composed frame in the RAM via memory controller 740, which serves as an arbiter controlling the access of different resources to the RAM.

Similarly, PCI bridge 705 couples to audio buffer 710b, which temporarily stores audio data and commands transmitted from the application driver. In turn, the audio engine 720 retrieves the stored data and commands from buffer 710b and, based on them, composes the audio data accompanying the generated graphical frames. Audio engine 720 also stores its generated audio data in RAM 625 (which can be a DRAM) via memory controller 740.

Memory controller 740 also couples RAM 625 to frame preparation engine 725 and compression engine 730. Through this coupling, frame preparation engine 725 retrieves graphical frames and performs digital filtering operations, such as audio-visual artifact correcting operations, image scaling operations, and flicker reduction operations. After the frame preparation engine completes its operations, it either (1) supplies the frame to the compression engine, if this engine is idle, or (2) stores the frame back in the RAM to be retrieved by the compression engine at a later time.

Compression engine compresses the graphical frames. In one embodiment of the invention, this engine uses a known compression technique (such as an MPEG compression technique) to compress the composed data frames for transmission. The compression engine then either (1) supplies the compressed frames to MAC 735 if the

WO 98/34378

PCT/US98/01820

MAC needs a graphical data frame, or (2) stores the compressed frames in the memory to be retrieved at a later time by the MAC.

The MAC sets a flag in the RAM in order to inform the compression engine that it is ready for a graphical data frame. Hence, if the MAC's flag is set (indicating that the MAC is ready for data) then the compression engine sends the compressed data (e.g., the first compressed byte) to the MAC, which will then feed it to the radio transceiver for transmission. If the flag is not set, the compression engine determines that the MAC is not ready for receiving graphical data, and thereby stores the data in the RAM.

The MAC also retrieves from the memory the stored audio data for transmission via the digital transceiver. This controller synchronizes the visual and audio data components, so that they are presented synchronously at the appliance unit. Specifically, the MAC links the audio and the visual data (merges the two generated graphic and audio frames), in order to allow the computer system to provide a multimedia presentation. Linking the two data types is an important function because otherwise the video and audio would not be displayed in a synchronous fashion (i.e., lead to synchronization errors such as lip synch errors).

MAC 735 also interfaces with the digital transceiver to supply data to, and receive data from, it. In one embodiment of the invention, MAC 735 implements an isochronous protocol and is called an isochronous media access controller ("IMAC"). An IMAC is a communication controller that can handle time dependent data, such as audio and visual data. Isochronous data is typically transmitted through a connection oriented network (such as a fixed point-to-point network or a circuit-switched network). This controller's protocol is in contrast to other media access controller protocols which process the

transmission of network data without guaranteeing delivery times or packet orders; non-isochronous protocols typically use a packet-switched network.

The MAC, like several other modules of the ASIC (such as the buffers 710, the graphic engine 715, the audio engine 720, the frame preparation engine 725, and the compression engine 730), couples to the interrupt (IRQ) line 745. The signal on this line is active whenever the MAC needs to inform the I/O driver of the computer that it has received an input command from the appliance unit. This signal is also active whenever the system needs to be notified that the PCI card needs service. An interrupt controller (not shown) would then respond to the interrupt signal.

The operation of the ASIC is as follows. Initially, the circuitry of the ASIC is reset by asserting an active signal on a reset line (not shown) coupled to all the ASIC circuitry. Upon reset, the RAM is cleared and the memory controller is set back to a reset state. Also, upon reset, the PCI plug-in-play software (stored in storage 435) ensures the proper IRQ mapping and proper PCI address space mapping for card 615.

An application program then transmits a high-level graphical command for presentations at the computer I/O node and/or the appliance unit. This command is intercepted by an output driver (such as virtual output driver VOFD described below by reference to **Figure 13**). If this intercepted command is also for a presentations at the appliance unit, this driver then forwards a copy of it to the PCI-mapped graphics buffer via the PCI bridge. The graphics engine then translates the display data command (such as a bit BLT command) to compose an image, which it then stores in the RAM.

WO 98/34378

PCT/US98/01820

Once the graphics engine stores a complete frame in the RAM (which serves as a frame buffer), a flag is set in the ASIC. After reset, the frame preparations engine periodically polls this flag to determine whether the RAM stores a composed frame. Once this flag is set, the frame preparation engine starts reading the frame line by line in order to perform digital filtering operations, such as audio-visual artifact correcting operations, image scaling operations, and flicker reduction operations.

After the frame preparation operations, the compression engine obtains the graphical frame in order to compress it. One embodiment of the compression engine, which uses an MPEG1 encoding scheme, maintains a non-compressed composed frame in the RAM. It then uses the non-compressed frame to compress subsequent frames. After the compression, the MAC obtains the compressed frame, prepares it for transmission, and supplies it to the digital transceiver for transmission to the appliance unit.

ASIC 700 processes audio data similarly. Specifically, in case where the application program (running on computer system 600) has audio components, drivers 435 receive audio commands and forward these commands to the audio buffer of the ASIC. In turn, the audio engine takes these audio commands, generates audio data from these commands, and then stores this data in the RAM. The audio data is then retrieved by the MAC, which synchronizes it with the graphical data, and supplies it to the transceiver.

Figure 8 presents one embodiment of the I/O control unit 492 of the appliance unit of **Figures 4-6**. This embodiment can couple to a television and speakers at the appliance unit. In one embodiment of the invention, I/O control unit 800 is part of a settop box which connects to a television. One such settop box is accompanied by wireless keyboard and cursor controller, which serve as the input devices for the appliance unit.

As shown in **Figure 8**, this control unit includes ASIC 805, RAM 805, NTSC/PAL encoder 815, input port 820. This control unit couples to digital transceiver 490, which in one embodiment of the invention is a spread-spectrum radio transceiver. This transceiver transmits signals to, and receives signals from, digital transceiver 635 of computer 605. In turn, this transceiver receives signals from, and supplies signals to, ASIC 805.

More specifically, the transceiver supplies received signals to ASIC 805. In one embodiment of the invention, the transceiver receives composed and compressed audio-visual data. In this embodiment, the ASIC decompresses the audio-visual data prior to presentation. As mentioned above, the compression engine of one embodiment of the invention uses an MPEG1 encoding scheme. Hence, for this embodiment of the invention, ASIC 805 obtains the audio-visual data by performing an MPEG1 decoding operation.

ASIC 805 also couples to RAM 810 and input port 820. It uses the RAM to store signals received from transceiver 490 and input port 820. Furthermore, through the input port, the ASIC receives information from a user of the appliance unit. In particular, this port receives signals from the appliance unit's input devices (such as a cursor controller, keyboard, etc.), converts these signals into digital data, and then supplies them to the ASIC. In one embodiment of the invention, this interface is either a wireless transceiver (such as an infrared or radio transceiver) or a wired port.

The ASIC then formats for transmission the information it received from the input port, and supplies the formatted data to transceiver 490 to transmit across the wireless channel to computer 605. This transmitted information causes the computer to perform certain operations, which in turn can affect the audio-visual presentation viewed by the user at the appliance unit.

ASIC 805 further couples to encoder 815. This encoder (1) receives the digital visual information previously decoded by ASIC 805, and (2) converts this digital information into an analog format. Specifically, in one embodiment of the invention, encoder performs a matrix encoding process by taking digital YCrCb representations and realizing the complex encoding of either NTSC standard or PAL standard.

This encoder couples to the ASIC via unidirectional signal link 825 and bi-directional control link 830. Through the unidirectional link, the ASIC provides data to encoder 815. The ASIC uses the control link to transmit and receive control signals (such as horizontal sync, vertical sync, even/odd frame, etc.) to and from the encoder. ASIC 805 also couples to audio data link 835, which provides the audio output of the ASIC. This audio link also connects to a digital-to-analog converter ("DAC") 845, which converts the received digital audio to an analog format and thereby provides an analog audio output.

Figure 9 presents one embodiment of ASIC 805 of **Figure 8**. As shown in **Figure 9**, ASIC 900 includes MAC 905, memory controller 910, decompression engine 915, digital filtering engine 920, audio processing engine 925, NTSC controller interface 930, command buffer 935, peripheral controller 940, and input port 945.

MAC 905 controls the flow of information to and from digital transceiver 940 through a bi-directional link. One embodiment of MAC 905 is an IMAC. The MAC deposits transmitted signals in, or pulls the received signals out of, RAM 810 through memory controller 910, which acts as an interface between RAM 810 and the circuitry of ASIC 900.

More specifically, in certain instances, the MAC retrieves information from RAM 810, and supplies the retrieved information to transceiver 490 for transmission back to computer 605. For instance, if a user of the appliance unit transmits a signal to I/O control unit, the MAC obtains the transmitted information stored in RAM 810 and forwards it to computer 605 via transceiver 490.

As mentioned above, input port 820 (which can be a wireless infrared transceiver) receives the signals transmitted by the appliance unit's user. This port then supplies the transmitted signal to input interface 945. In one embodiment, this interface is an infrared devices association ("IRDA") interface. This device uses a standard protocol for infrared devices to identify the appliance unit's input device that transmitted the signal, and to convert the transmitted infrared signal to digital data readable by ASIC 900.

The digital data then is supplied to peripheral controller 940, which may either be fixed function logic or microcontroller for interpreting the data and identifying the input signal (e.g., identifying the keystroke or mouse movement). The controller then stores the identified input signal in command buffer 935, which under the control of memory controller 910 eventually forwards the received input signal to RAM 810. The command buffer is provided just in case the received input signals cannot be stored immediately in the RAM (e.g., in case the RAM is being accessed by another unit, such as when a frame is being stored in the RAM). Once an input signal is stored in the RAM, a flag is set (by the peripheral controller) to alert the MAC that it needs to retrieve input commands from RAM 810 and forward them to transceiver 490.

MAC 905 also forwards all the information transmitted from digital transceiver 490 into memory 810 via memory controller 910. Once the MAC stores a complete frame in

WO 98/34378

PCT/US98/01820

the memory, it sets a flag in the memory to indicate that a complete frame has been received from the transceiver. The decompression engine then detects the setting of the flag and accesses the RAM via the memory controller to retrieve the received, compressed information. The decompression engine then decompresses this information, by performing the inverse function of the compression function (e.g., performing MPEG decompression) used at the computer 605.

The decompression engine then supplies the decompressed information to a digital filtering engine 920, which uses one or more digital filtering processes to correct any audio-visual artifacts introduced during the transmission. One version of the decompressed and digitally-filtered information is then stored back in the DRAM. The decompression engine uses this version to decompress subsequent frames. Another version of the decompressed and digitally-filtered frame is supplied to controller interface 930, which serves as a control interface with encoder 815. This output of digital filtering engine 920 is also placed on link 840, as discussed above.

The decompression engine also couples to audio processing engine 925. The audio processing engine extracts the audio sequence and corrects errors in the audio stream. The output of the audio processing engine is then supplied to the controller interface. The controller interface assures that the signals it supplies to encoder 815 comply with this encoder's specifications. This interface also maintains the synchronicity between the audio frame output of the audio engine and the video frame output of the digital filtering engine, by using the synch control signal 950 supplied by encoder 815. The synch control signal is a basic set of timing signals consistent with the specification of encoder 815 (e.g., with the NTSC specification).

WO 98/34378

PCT/US98/01820

The operation of ASIC 900 during reception of signals from computer 605 will now be described. When the I/O control unit resets, the storage locations in the RAM are resets to clear states. The controller interface would then begin receiving synchs simultaneous to the display device allowing audio sample clock to align for later first reception of audio (audio would remain muted until such time).

The synch signals start the operation of ASIC 900, by causing the decompression engine to start looking to the RAM to determine if a flag has been set by the MAC to indicate that a complete frame has been received and stored. Once a flag is set, the decompression engine would retrieve a frame to decompress it.

After a predetermined amount of information has been decompressed, the digital filtering process begins. The digital filter generates a first type of information for display by accessing the streaming information coming from the decompression engine and the stored parameters (from the memory) needed to reconstruct the frame for display.

Similarly, after a predetermined amount of information has been decompressed, the audio engine begins processing the decompressed audio information, which it supplies to the controller interface. This process would continue in a pipeline fashion throughout the reception of the frame, whereby the MAC stores the compressed information in memory, the decompression engine accesses this information and decompresses it, the filtering engine processes the visual-portion of the decompressed information with parameters it obtains from the memory, and the audio engine process the audio portion of the decompressed information.

Figure 10 presents one embodiment of digital transceivers used in the invention. As shown in this figure, one embodiment of digital transceiver 1000 includes power amplifier 1005, frequency converter 1010, modulator/demodulator 1015, and baseband processor 1020. The baseband processor couples to the MAC, which implements the wireless protocol of the transceiver. This controller transmits data to, and receives data from, the baseband processor, which prepares the data stream for transmission. For the embodiments of the transceiver 1000 which utilize spread-spectrum technology, processor 1020 performs pseudo-noise code spreading. It also provides scrambling for interference rejection, antenna diversity for better coverage, and received signal strength indication.

The output of the baseband processor is supplied to modulator 1015. This intermediate frequency ("IF") modulator then encode and modulates the baseband data to place the data in an intermediate frequency range (e.g., uses QPSK encoding to modulate the data between 200 MHz and 400 MHz). The encoded and modulated data is then pushed to a higher frequency range (e.g., 2.4 GHz, which is the allowed, unlicensed spread spectrum frequency band) by up-converter 1010. The high-frequency data is then amplified by power amplifier 1005 and transmitted via an antenna.

Transceiver 1000 operates in a complementary fashion when it receives a signal. Specifically, the antenna supplies the received signal to low noise amplifier 1005 to amplify the signal. The high-frequency, amplified signal is then converted to an intermediate frequency range by down-converter 1010. The IF modulator/demodulator 1015 demodulates and decodes the filtered, intermediate-frequency signal to obtain a baseband signal, which it supplies to baseband processor 1020. After processing this signal, this processor then notifies the MAC that it has received data.

Figure 11 presents a flowchart of the software for one embodiment of the invention. This process can be implemented as part of the application program, the operating system, and/or the I/O drivers. Process 1100 of **Figure 11** starts at step 1105 when the computer is turned on.

The process then transitions to step 1110, where a determination is made whether a new audio-visual instruction has been received. For instance, one embodiment of process 1100 makes this determination by checking the setting of a flag at a memory location. If no new instruction has been received, the process transitions back to step 1110 to check for a new instructions arrival in the next time interval.

However, if a new instruction has been received, the process then determines, at step 1115, whether a presentation is being presented at the local I/O node. If not, the process transitions to step 1125. If so, the process forwards the instruction to the local I/O node's processing engine, at step 1120. Based on the audio-visual instruction, the local I/O node's processing engine then composes an audio-visual data stream for presentation at the local node.

Next, the process transitions to step 1125. At this step, a determination is made whether the a presentation is being presented at the remote appliance unit. If not, the process transitions back to step 1110 to check for a new instructions arrival in the next time interval. On the other hand, if received audio-visual instruction is also for a presentation at the appliance unit 415, the process forwards the instruction to the appliance unit's processing engine, at step 1130. The appliance unit's processing engine then composes an audio-visual data stream (based on the audio-visual instruction) for presentation at the appliance unit. As discussed above, this processing engine either is a

part of the computer (e.g., is part of a processor or an ASIC) or it is a part of the logic at the appliance unit (e.g., is part of I/O control unit 492).

From step 1130, the process transitions step 1135 where it terminates this cycle. In the next cycle, process 1100 returns to step 1110 to check for a new instructions arrival in the next time interval. The process continues to cycle until the computer or remote node is turned off.

Figure 12 presents the general operational flow of one embodiment of the invention, in which the above-described process 1100 of **Figure 11** is performed by I/O drivers. In this embodiment, application program 1205 first generates high level audio-visual command, which it supplies to operating system 1210. The operating systems then converts the high level commands to audio-visual primitives, and forwards these primitives to I/O drivers 1215.

The I/O drivers then decide whether a presentation is being presented at the local I/O node. If the audio-visual instructions are directed to the local I/O node, drivers 1215 route this instruction to the local I/O processing engine. This engine, in turn, composes audio-visual data based on the instructions and forwards the data to the local node for presentation at the local output device. For instance, based on received high-level graphic commands, the local I/O engine can prepare digital RGB frames, which are then converted to analog RGB data to drive the electron gun of the cathode ray tube ("CRT") of a PC monitor at the local node.

If the instruction is not directed to a presentation at the local I/O node (i.e., if no presentation is being presented at the local I/O node) or if it is also directed to a

WO 98/34378

PCT/US98/01820

presentation at the appliance unit, drivers 1215 then route it to the appliance unit's processing engine. One of ordinary skill in the art would realize that, even though **Figure 12** pictorially presents two different I/O processing engines, in one embodiment of the invention these two processing engines share the same hardware engine while utilizing non-identical software (i.e., while utilizing different instruction sequence).

Based on the received audio-visual command, one embodiment of appliance unit's processing engine 415 composes audio-visual data for presentation at the appliance unit. For instance, based on received instructions, one embodiment of the appliance unit's I/O engine composes digital YCrCb data. The computer's digital transceiver then transmits the composed audio-visual data to the appliance unit.

The appliance unit's transceiver then receives the transmitted data, which it passes to the appliance unit's I/O control unit. This control unit decodes the received signal to extract the composed audio-visual data. One embodiment of the I/O control unit also encodes the extracted audio-visual data in a unique format for presentations at the remote output device. For example, in one embodiment of the invention, I/O control unit receives YCrCb signals, and converts these signals to NTSC or PAL encoded signals for display on the television.

An alternative embodiment of the appliance unit's I/O processing engine does not compose the audio-visual data for the appliance unit, but rather transmits the audio-visual commands to the appliance unit. In this embodiment, I/O control unit 492 first decodes the received signal, and then composes audio-visual data based on it.

WO 98/34378

PCT/US98/01820

In yet another embodiment of the invention, appliance unit I/O processing engine transmits particular audio-visual commands to the appliance unit's I/O control unit, while also composing and transmitting audio-visual data based on other audio-visual commands. In this embodiment, the I/O control unit extracts the received commands and data, and composes additional audio-visual data based on the extracted commands.

Thus, as shown in **Figure 12**, one embodiment of the invention taps out the information for the appliance unit at an earlier operational stage than the prior art systems of **Figures 1 and 2**. Hence, unlike the prior art systems, one embodiment of the invention does not generate the I/O data for presentation at the appliance unit by intercepting and converting the I/O data for presentation at the local node. Rather, one embodiment of the invention intercepts the audio-visual commands before they have been processed for the local node, and forwards them to the unique I/O processing engine of the appliance unit.

In this manner, the presentation presented at the appliance unit has superior quality, because it is composed in a output type sensitive fashion. Specifically, the presentation at the appliance unit has not been generated based on a presentation for the particular output devices at the local node, but rather has been specifically tailored for the output devices at the appliance unit.

For example, when the local node's output device is a PC monitor and the appliance unit's output device is television, the television's NTSC or PAL presentation is not based on analog RGB signals generated for the PC monitor. Rather, this display has been specifically composed from the audio-visual commands for the television. For instance, in one embodiment of the invention, the appliance unit's I/O engine composes YCrCb digital display data from graphical instructions, for a television presentation.

Figure 13 sets forth the software architecture of one embodiment of the invention. This embodiment leverages functionality found in existing operating systems (such as Windows 95®), by utilizing its native display, sound, keyboard, and mouse drivers. This embodiment includes an application program 1305, an operating system 1310, a number of I/O drivers, and a dynamic link library 1315.

The application program performs certain types of tasks by manipulating text, numbers, and/or graphics. Examples of such a program include word processing programs, such as Microsoft Word®, or a multi-media game program, such as Nascar Auto-Racing®. Application program 1305 interfaces with the components and modules of the computer through operating system 1310. Examples of such an operating system include Microsoft Windows 95® and Microsoft NT®. The operating system serves as the foundation on which application programs operate and controls the allocation and usage of hardware and software resources (such as memory, processor, storage space, peripheral devices, drivers, etc.). As shown in **Figure 13**, operating system 1310 serves as the interface between application program 1305 and I/O drivers. Thus, the application program transmits and receives instructions to and from the drivers via the operating system.

The software for performing I/O tasks is usually organized into device drivers. Drivers are control programs that enable a computer to work with output devices (i.e., provide the instructions necessary for controlling the I/O devices). They are called by the application program whenever I/O processing is required. Even though **Figure 13** presents the drivers as separate modules than the operating system, one of ordinary skill in the art would realize that, in one embodiment of the invention, some or all of these device drivers

WO 98/34378

PCT/US98/01820

are operating system subroutines. Also, one of ordinary skill in the art would realize that certain drivers accompany the application programs.

Drivers include an output set of drivers 1320 for regulating the operation of output devices, such as display devices and printers, and input set of drivers 1325 for regulating the operation of input devices, such as the keyboard and the cursor controllers.

Output Set of Drivers

For the embodiment shown in **Figure 13**, the output set of drivers include VOVD 1330, VDD 1335, and VSD 1340. VOVD stands for virtual output filter driver. This driver is responsible for passing a copy of the audio and graphics calls, which the operating system invokes for audio-visual presentations at the local node, to the appliance unit's I/O processing engine, if the received instruction is also for a presentation at the appliance unit.

VDD and VSD respectively stand for virtual display driver and virtual sound driver, and are device-specific control programs for respectively regulating the operation of the display device and the speakers. In one embodiment of the invention, VDD and VSD are standard device drivers accompanying the Windows 95® operating system.

The operation of the output drivers will now be described. Initially, the application program issues a high level audio-visual instruction (e.g., line draw) for a presentation at the local I/O node and/or the appliance unit. Depending on whether the instruction is an audio instruction or a video instruction, the operating system then issues an audio call or a graphics call to invoke either VSD or VDD to write to the audio engine or the graphics engine of the I/O processing engine.

In one embodiment of the invention, these calls, in turn, first cause the VOFD driver to be invoked. For this embodiment, the pseudo code relating to one embodiment of VOFD is recited below.

```

Pseudo Code for VOFD
if Graphics_Call then
begin
  If TextOut then
  begin
    Read Text_Attribute
    VxDcall Prez_TextRemap
  end
  Write Remote_Display_Reg
end
else if Audio_Event then
begin
  If MIDI then
    read MIDI_Interface
  else
    read Audio_Attribute
  Write Remote_Audio_Reg
end
end
clear_flags
RET

```

VOFD forwards the graphic call (e.g., the graphical device interface, GDI, call in Windows®) or the audio call to the graphics engine or audio engine of the local node. As apparent from the pseudo code recited above, this driver also forwards copies of the graphics and audio calls to the graphics and audio engines of the appliance unit. In addition, if this driver detects graphical text string calls (e.g., GDI text string calls), it invokes Prez.dll for post processing text in order to prepare it for display on the remote display terminal (e.g., post processing text for TV compliant display).

Specifically, VxDcall Prez_TextRemap command invokes Prez.dll for post processing text to be compliant with the display standards of the remote display terminal.

WO 98/34378

PCT/US98/01820

Thus, once the VOFD determines that the application's command is a graphics text string call, it invokes Prez.dll to perform the remapping that is necessary for displaying the text intended for the local display device on the remote display device. This remapping can include font color remapping, font type remapping, font rescaling, etc. Prez.dll then writes the remapped instructions in the graphics processing engine. VOFD then writes a copy of the graphics call to graphics engine of the appliance unit's I/O processing engine.

On the other hand, if VOFD determines that the OS call is an audio instruction, and if the driver determines that the audio instructions are in a MIDI (i.e., a musical instrument digital interface) format, it reads the MIDI_Interface to obtain the audio content. Otherwise, it reads the audio attribute contained in the Audio_Event instruction. In either case, VOFD then writes the audio content (obtained from the MIDI interface or the audio instruction) in the audio engine of the appliance unit's I/O processing engine. Finally, VOFD clears the flags (e.g., the flag that causes VOFD to be called) and resets to await for additional audio-visual instructions.

Input Drivers

For the embodiment shown in **Figure 13**, the input set of drivers includes VID 1345, VKD 1355, and VMD 1350. VID stands for virtual input driver. This driver services remote input devices, by passing the data from the appliance units to the application program via VKD, VMD, and the operating system. The data from the local I/O node is directly serviced by VKD and VMD.

VKD and VMD respectively stand for virtual keyboard driver and virtual mouse driver, and are device-specific control programs for respectively regulating the operation of

the keyboard and the mouse. In one embodiment of the invention, VKD and VMD are standard device drivers accompanying the Windows 95® operating system.

The operation of the input drivers will now be described by reference to the pseudo code for one embodiment of VID driver recited below.

Pseudo Code for VID

```

if PCCARD_IRQ then
begin
  Read Remote_IQ_reg
  if Keyboard_Activity then
  begin
    Read ScanCode
    Read RepeatCount
    Read ShiftState
    VxDcall VKD_API_Force_Key
  end
else if Mouse_Activity then
begin
  Read AbsoluteX
  Read AbsoluteY
  Read ButtonStatus
  VxDcall VMD_Post_Absolute_Pointer_Message
end
end
clear_flags
RET

```

As set forth in the pseudo code recited above, one embodiment of VID starts once PCCARD_IRQ signal is active. The VID then reads the data in the I/O register of the remote processing engine. If this data pertains to a keyboard activity at the appliance unit (e.g., a flag has been set to indicate that the data relates to a keyboard activity), the driver then extracts the scan code, repeat count, and shift state from the keyboard data. It then forwards this extracted information to the application program via VKD and the operating system. In other words, VID invokes VKD in order to use the standard application

WO 98/34378

PCT/US98/01820

programming interfaces (APIs) exported by the VKD to forward the extracted data to the application program.

On the other hand, if the data in the I/O register of the remote processing engine pertains to a mouse activity, VID extracts the cursor positional data (absolute X and absolute Y) and the button value data from the I/O register data. This driver then invokes VMD to use its standard APIs to forward the extracted data to the application program. Finally, VID clears the flags (e.g., the flag that causes VID to be called) and resets to await for additional input commands.

As apparent from the discussion above, the invention is advantageous because it provides a method and apparatus for incorporating an appliance into a computer system through a wireless link. It uses superior digital wireless communication link. Several embodiments of the invention utilize direct sequence coding, spread spectrum link. Such a link is immune from interference noise (such as intra-cell interference noise generated in the communication cell formed around the periphery of the computer and the appliance unit, or inter-cell interference noise generated by noise sources outside of the communication cell formed by the computer and the appliance unit).

A direct sequence coding spread spectrum link also provides protection against the multipath phenomena, because the multipath signals appear as uncorrelated noise to the spread spectrum receiver. Thus, when such a link is used, the quality of the transmitted I/O data and the output presentation is not deteriorated. The embodiments of the invention that utilize other digital transceivers, guard against signal degradation due to noise by performing error coding and decoding.

Many embodiments of the invention also provide a secure digital communication link. For example, the embodiments of the invention that utilize direct sequence coding spread spectrum links, utilize encoding codes to spread the signals over the available bandwidth, and transmits data in this encoded fashion. Only the receiver has the encoding code, and thus only the receiver can decode the transmitted data. Thus, eavesdroppers cannot tap into the communications between the computer and the appliance unit. Protection against eavesdroppers is also an advantage of the embodiments of the invention that utilize other digital transceivers which transmit and receive encrypted data.

Also, one embodiment of the invention taps out the information for the appliance unit at the command level and not the data level of the prior art. Hence, unlike the prior art systems, one embodiment of the invention does not generate the I/O data for presentation at the appliance unit (e.g., does not generate analog NTSC or PAL encoded signals for a television) by intercepting and converting the I/O data for presentation at the local node (e.g., intercepting and converting the analog RGB signals for a PC monitor). Rather, for the appliance unit, one embodiment of the invention intercepts the audio-visual commands before they have been processed for the local node, and forwards them to the unique I/O processing engine of the appliance unit.

In this manner, the presentation presented at the appliance unit has superior quality, because it is composed in a output type sensitive fashion. Specifically, the presentation at the appliance unit has not been generated based on a presentation for the particular output devices at the local node, but rather has been specifically tailored for the output devices at the appliance unit. For example, when the local node's output device is a PC monitor and the appliance unit's output device is television, the television display is not based on

WO 98/34378

PCT/US98/01820

analog RGB signals generated for the PC monitor. Rather, this display has been specifically composed from the graphics commands for the television. For instance, in one embodiment of the invention, the appliance unit's I/O engine composes YCrCb digital display data from graphical instructions.

While the invention has been described with reference to numerous specific details, one of ordinary skill in the art would recognize that the invention can be embodied in other specific forms without departing from the spirit of the invention. For example, even though some of the above-discussed embodiments (e.g., the embodiment set forth in **Figure 4**) have been described as processing audio-visual data and commands, one of ordinary skill in the art would appreciate that alternative embodiments of the invention process other types of multi-media data and commands (such as tactile data and commands).

Moreover, while **Figure 7** presents a specific example of the ASIC of **Figure 6**, other embodiments of the ASIC of **Figure 6** perform different tasks than the ones performed by ASIC 700. For instance, the compression operation can be performed outside of ASIC 620. Thus, one of ordinary skill in the art would understand that the invention is not to be limited by the foregoing illustrative details, but rather is to be defined by the appended claims.

CLAIMS

We claim:

1. A method for incorporating an appliance unit into a computer system, the method comprising the steps of:
 - (a) establishing a digital wireless communication link between an appliance unit and a computer;
 - (b) providing an output display presentation on a display screen of the appliance unit based on the signals transmitted from the computer via said link.
2. The method of claim 1, wherein said link establishing step comprises the step of establishing a spread spectrum wireless link.
3. The method of claim 1, wherein said link establishing step comprises the step of establishing a spread spectrum wireless link between the computer and an audio-visual equipment.
4. The method of claim 1, wherein said link establishing step comprises the step of establishing a spread spectrum wireless link between the computer and a television.
5. A method of incorporating an appliance unit into a computer system, the method comprising the steps of:
 - (a) establishing a digital wireless communication link between the appliance unit and the computer;

WO 98/34378

PCT/US98/01820

- (b) receiving input commands from an input device of the appliance unit;
 - (c) forwarding the received input signals to the computer via the digital wireless link.
6. The method of claim 5 further comprising the steps of:
- (a) processing the input signals at the computer;
 - (b) in response to the processing of the input signals, transmitting signals from the computer to the appliance unit through the digital wireless link;
 - (c) providing an output presentation at an output device of the appliance unit based on the signals transmitted from the computer.
7. The method of claim 5 further comprising the steps of:
- (a) processing the input signals at the computer;
 - (b) in response to the processing of the input signals, modifying an operation performed on the computer.
8. The method of claim 7 wherein the modifying steps comprises the step of modifying the operation of a device coupled to the computer.
9. The method of claim 7 wherein the modifying steps comprises the step of modifying the operation of a peripheral device coupled to the computer.

WO 98/34378

PCT/US98/01820

10. The method of claim 7 wherein the modifying steps comprises the step of modifying the operation of another appliance unit coupled to the computer.
11. The method of claim 7 wherein the modifying steps comprises the step of modifying the operation of a second computer.
12. The method of claim 5 further comprising the steps of:
 - (a) transmitting signals from the computer to the appliance through said link;
 - (b) presenting an output presentation at an output device of the appliance based on the signals transmitted from the computer.
13. The method of claim 12, wherein said presentation step comprises the step of presenting an output display presentation on an output display screen of the appliance.
14. The method of claim 13, wherein said presentation step further comprises the step of presenting an output audio presentation at an output audio device of the appliance.
15. The method of claim 12, wherein said presentation step comprises the step of presenting an output audio presentation at an output audio device of the appliance.
16. The method of claim 12 further comprising the step of composing graphics data prior to said transmitting step, wherein said transmitting step includes the step of transmitting graphics data.

17. The method of claim 12 further comprising the step of composing audio data prior to said transmitting step, wherein said transmitting step includes the step of transmitting audio data.

18. The method of claim 12 further comprising the step of composing audio-visual data prior to said transmitting step, wherein said transmitting step includes the step of transmitting audio-visual data.

19. The method of claim 12 further comprising the step of compressing signals for transmission prior to the transmitting step, wherein said transmitting step includes the step of transmitting compressed signals.

20. The method of claim 12 further comprising the step of digitally encoding signals prior to said transmitting step, wherein said transmitting step includes the step of transmitting digitally encoded signals.

21. The method of claim 5, wherein said link establishing step includes the step of establishing a digital radio frequency ("RF") link.

22. The method of claim 5, wherein said link establishing step includes the step of establishing a spread spectrum link.

23. The method of claim 5, wherein said link establishing step includes the step of establishing an isochronous link.

24. The method of claim 5, wherein said link establishing step includes the step of establishing a real-time link.

WO 98/34378

PCT/US98/01820

25. The method of claim 5, wherein said link establishing step includes the step of establishing a multi-media link.

26. An apparatus for incorporating an appliance unit into a computer system, said appliance unit having a display screen, said apparatus comprising:

(a) a first digital transceiver for communicatively coupling to the computer;

(b) a second digital transceiver for communicatively coupling to the appliance unit, said transceivers for establishing a digital wireless link between the appliance and the computer;

(c) wherein, when a digital communication link is established, the computer transmits signals to the appliance unit and the appliance unit provides a presentation on the display screen based on the transmitted signals.

27. The apparatus of claim 26, wherein said transceivers are spread spectrum transceivers.

28. The apparatus of claim 26, wherein said appliance unit is an audio-visual equipment.

29. The apparatus of claim 26, wherein said appliance unit is a television.

30. An apparatus for incorporating an appliance unit into a computer system, said appliance unit having an input device, said apparatus comprising:

WO 98/34378

PCT/US98/01820

- (a) a first digital transceiver for communicatively coupling to the computer;
- (b) a second digital transceiver for communicatively coupling to the appliance unit, said transceivers for establishing a digital wireless link between the computer and the appliance;
- (c) wherein, when a digital communication link is established, the appliance unit forwards input signals received at the input device to the computer via the link.

31. The apparatus of claim 30 further comprising a control unit for communicatively coupling to the second transceiver and the input device, said control unit for controlling the communications between the input device and the second transceiver.

32. The apparatus of claim 31, wherein, when the control unit receives signals from the input device, it formats them for transmission.

33. The apparatus of claim 30, wherein said computer processes the input signals, and in response to this processing, modifies an operation.

34. The apparatus of claim 33, wherein said computer modifies an operation of a device coupled to it.

35. The apparatus of claim 33, wherein said computer modifies an operation of a peripheral device coupled to it.

36. The apparatus of claim 33, wherein said computer modifies an operation of another appliance coupled to it.

WO 98/34378

PCT/US98/01820

37. The apparatus of claim 33, wherein said computer modifies an operation of a second computer.

38. The apparatus of claim 30, wherein said appliance unit further has an output device, wherein said computer process the input signals, and in response to this processing, transmits signals to the appliance unit, the appliance unit providing an output presentation at its output device based on the signals transmitted from the computer.

39. The apparatus of claim 30, wherein said appliance unit further has an output device, wherein said computer transmits signals to the appliance unit via the link, and the appliance unit provides an output presentation at its output device based on the transmitted signals.

40. The apparatus of claim 39 further comprising an input/output control unit for communicatively coupling to the second transceiver, the input device, and the output device, said control unit for controlling the communications between the devices and the second transceiver.

41. The apparatus of claim 40, wherein,
when the control unit receives signals from the second transceiver, it formats them for presentation at the output device, and

when the control unit receives signals from the input device, it formats them for transmission.

42. The apparatus of claim 40, wherein the control unit has a decoding engine for digitally decoding the signals it receives from the second transceiver.

43. The apparatus of claim 40, wherein the control unit has a decompression engine for decompressing the signals it receives from the second transceiver.

44. The apparatus of claim 40, wherein the control unit has a digital filtering engine for filtering the signals it receives from the second transceiver.

45. The apparatus of claim 40, wherein the appliance is a television, the control unit has an encoder for encoding the signals it receives from the second transceiver into a television display format.

46. The apparatus of claim 39 further comprising a digital encoding engine communicatively coupled to the first transceiver, the digital encoding engine for digitally encoding signals prior to transmission to the appliance unit via the link.

47. The apparatus of claim 39 further comprising a compression engine communicatively coupled to the first transceiver, the compression engine for compressing signals prior to transmission to the appliance unit via the link.

48. The apparatus of claim 39 further comprising a digital filtering engine communicatively coupled to the first transceiver, the digital filtering engine for filtering signals prior to transmission to the appliance unit via the link.

49. The apparatus of claim 39 further comprising a graphics engine communicatively coupled to the first transceiver, the graphics engine for composing graphics data for transmission to the appliance unit via the link.

50. The apparatus of claim 39 further comprising audio engine communicatively coupled to the first transceiver, the audio engine for composing audio data prior for transmission to the appliance unit via the link.
51. The apparatus of claim 39 further comprising a frame synchronization engine communicatively coupled to the first transceiver, the frame synchronization engine synchronizing audio and visual data prior to transmission to the appliance unit via the link.
52. The apparatus of claim 39 further comprising a media access controller communicatively coupled to the first transceiver.
53. The apparatus of claim 52, wherein the media access controller uses an isochronous link protocol.
54. The apparatus of claim 39, wherein the transceivers are spread spectrum transceivers.
55. A computer system comprising:
- (a) a computer having a first digital wireless transceiver; and
 - (b) an appliance unit comprising:
 - (1) a second digital wireless transceiver for communicatively coupling to the first wireless transceiver,
 - (2) an output device communicatively coupled to the second transceiver, the output device for presenting an output presentation based on signals

received from the computer via the transceivers,

(3) an input device communicatively coupled to the second transceiver, the input device for receiving input signals from a user interfacing with the appliance unit, the input signals forwarded to the computer via the transceivers, and

(4) an input/output control unit communicatively coupling the second transceiver to the input and output devices.

56. For a computer system having (i) a computer with a first digital transceiver, and (ii) an appliance unit with an input device and an output device, an apparatus for wirelessly coupling the unit to the computer, the apparatus comprising:

(a) an input/output control unit for communicatively coupling to the input and output devices; and

(b) a second digital transceiver communicatively coupled to the input/output control unit, the second transceiver (i) for receiving signals from the first transceiver and passing the signals to the output device via the control unit, and (ii) for receiving signals from the input device via the control unit and transmitting the signals to the first transceiver,

wherein the output device provides an output presentation based on the signals received from the computer.

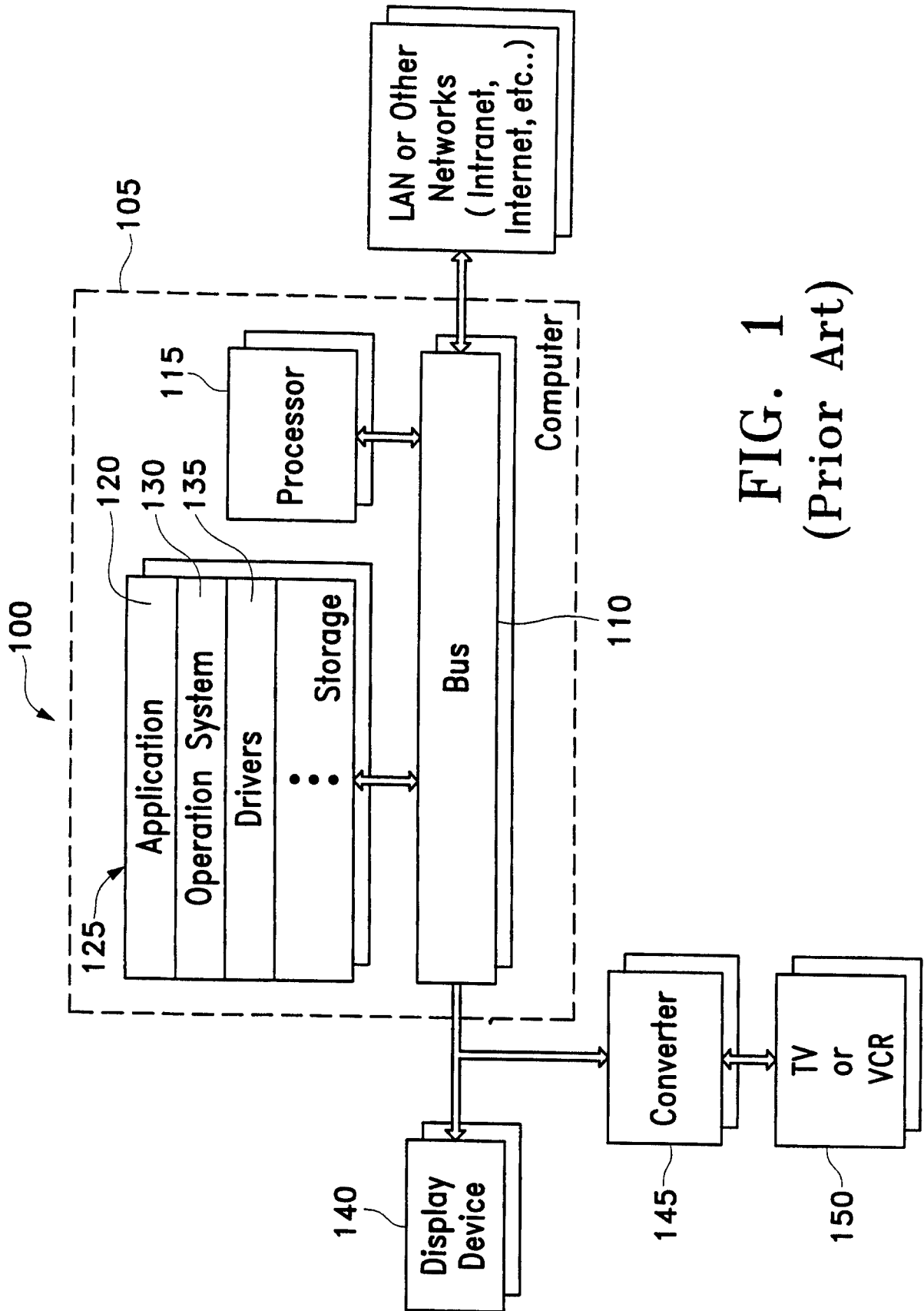

FIG. 1
(Prior Art)

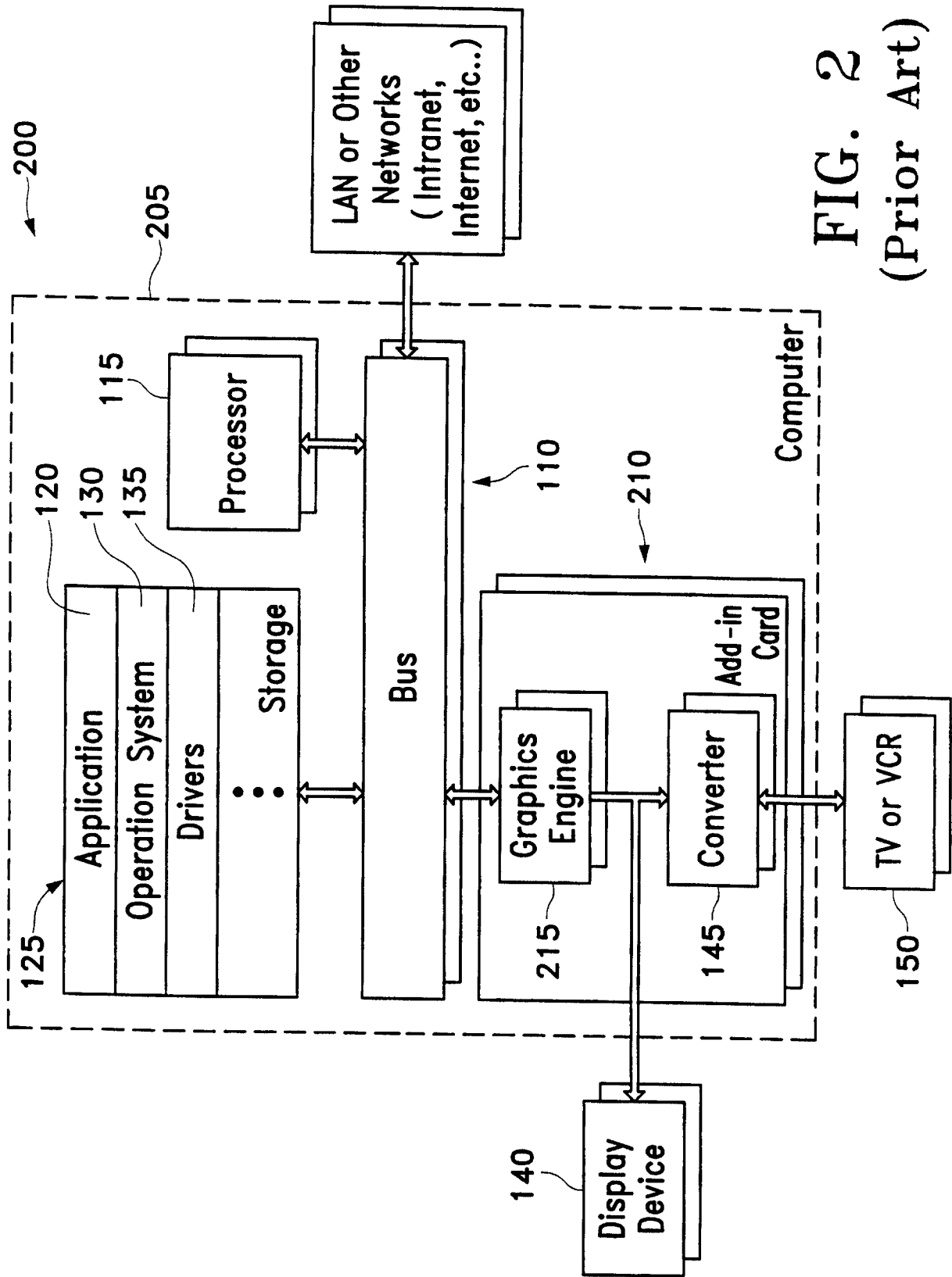

FIG. 2
(Prior Art)

3/13

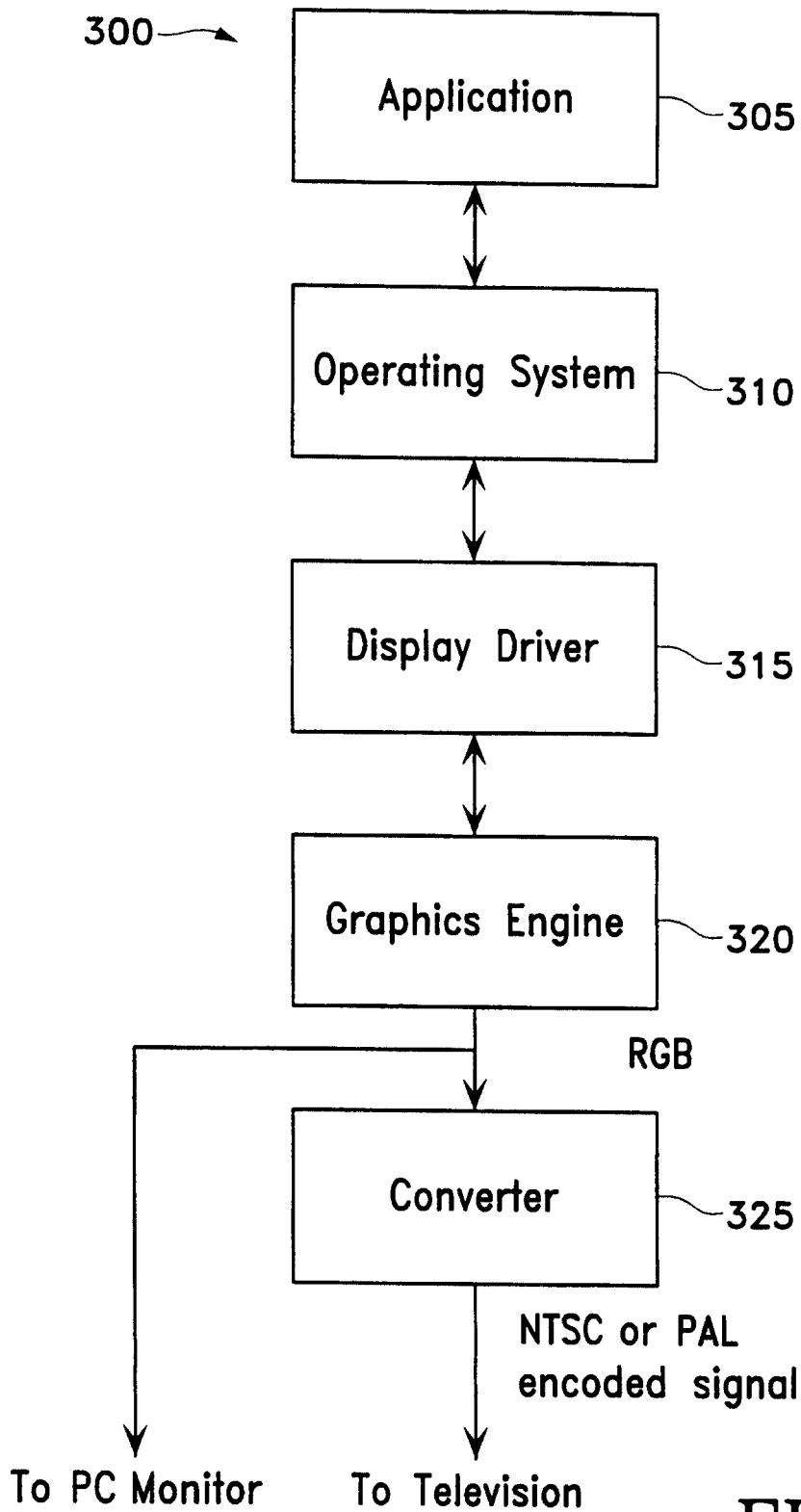

FIG. 3
(Prior Art)

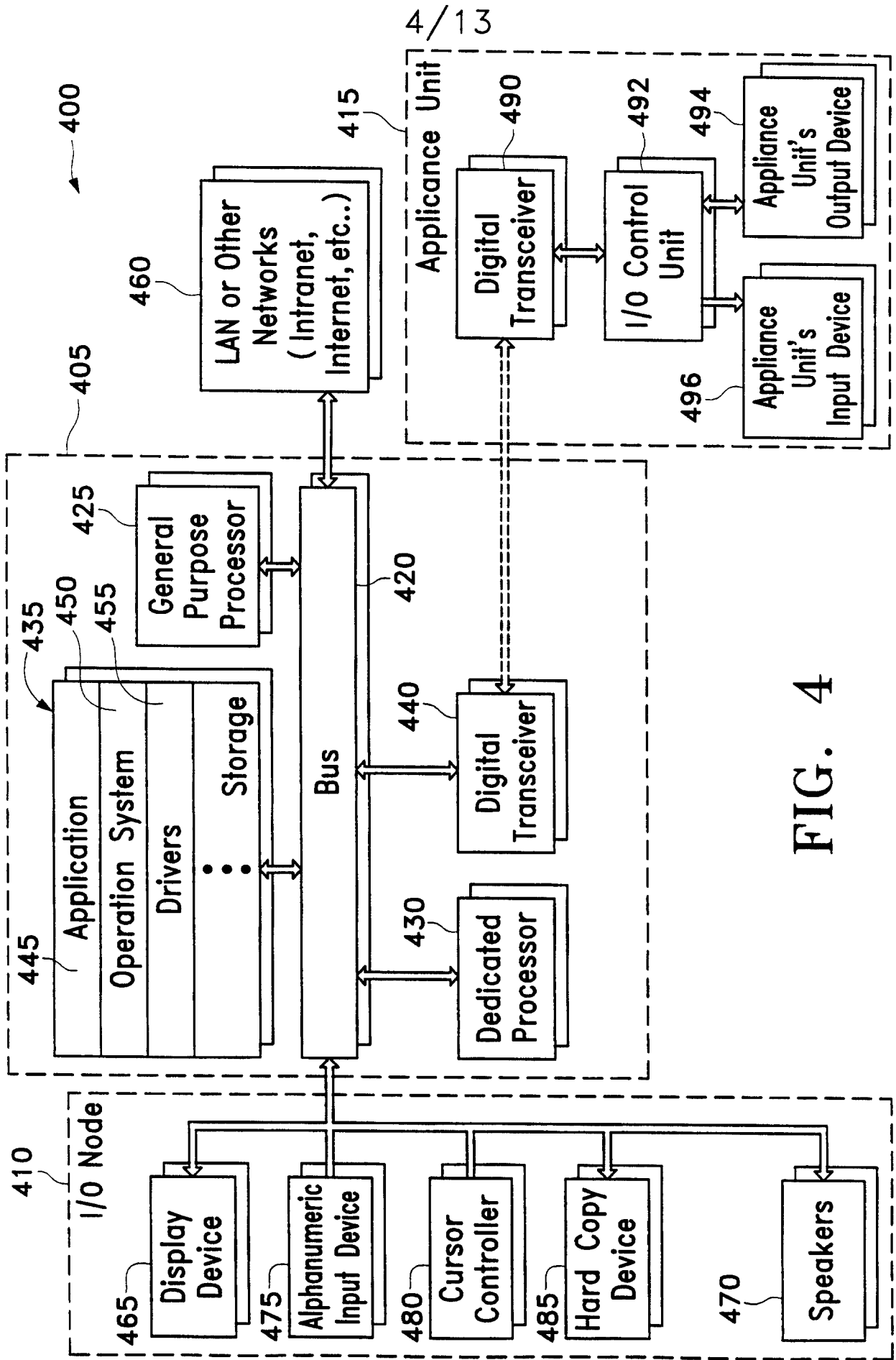

FIG. 4

5/13

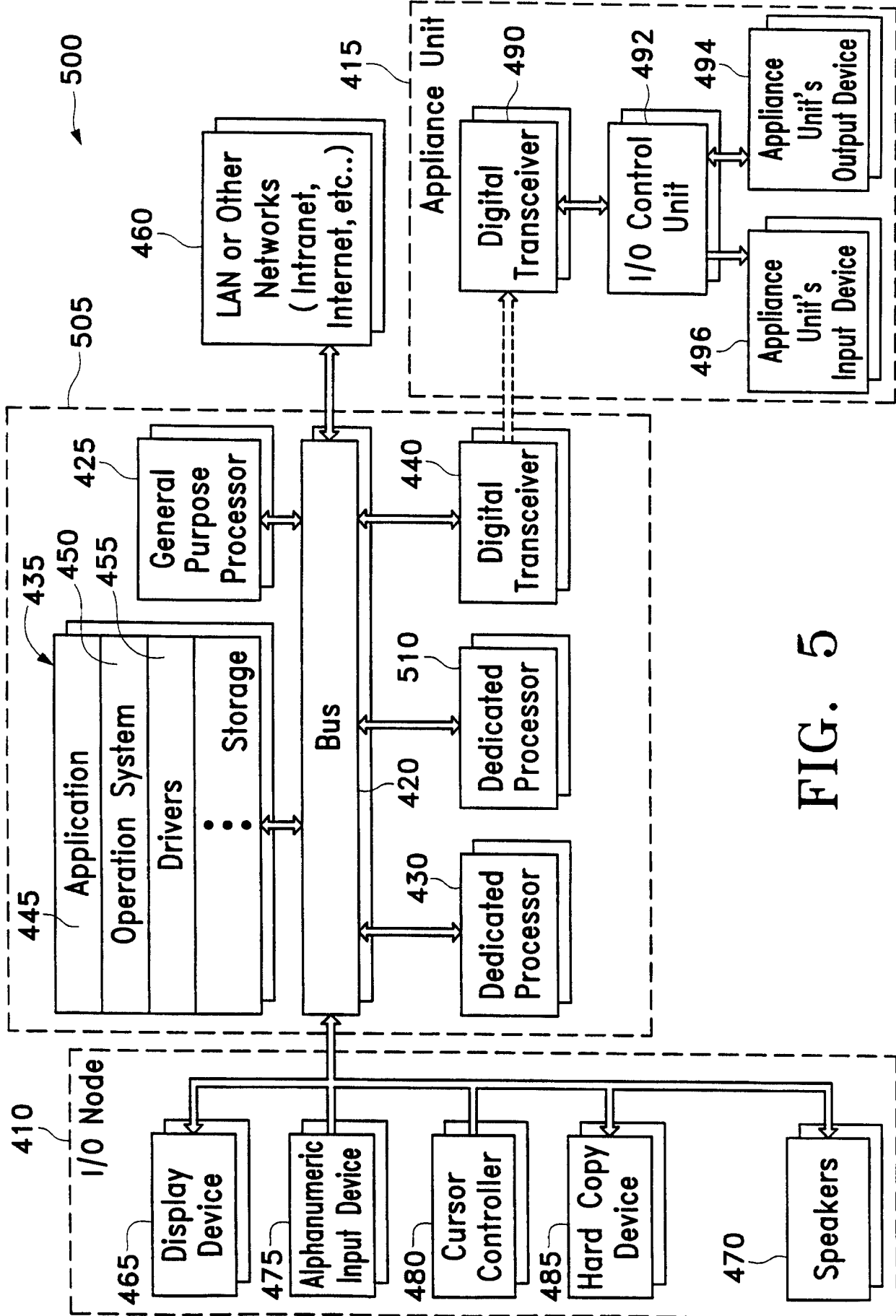

FIG. 5

6/13

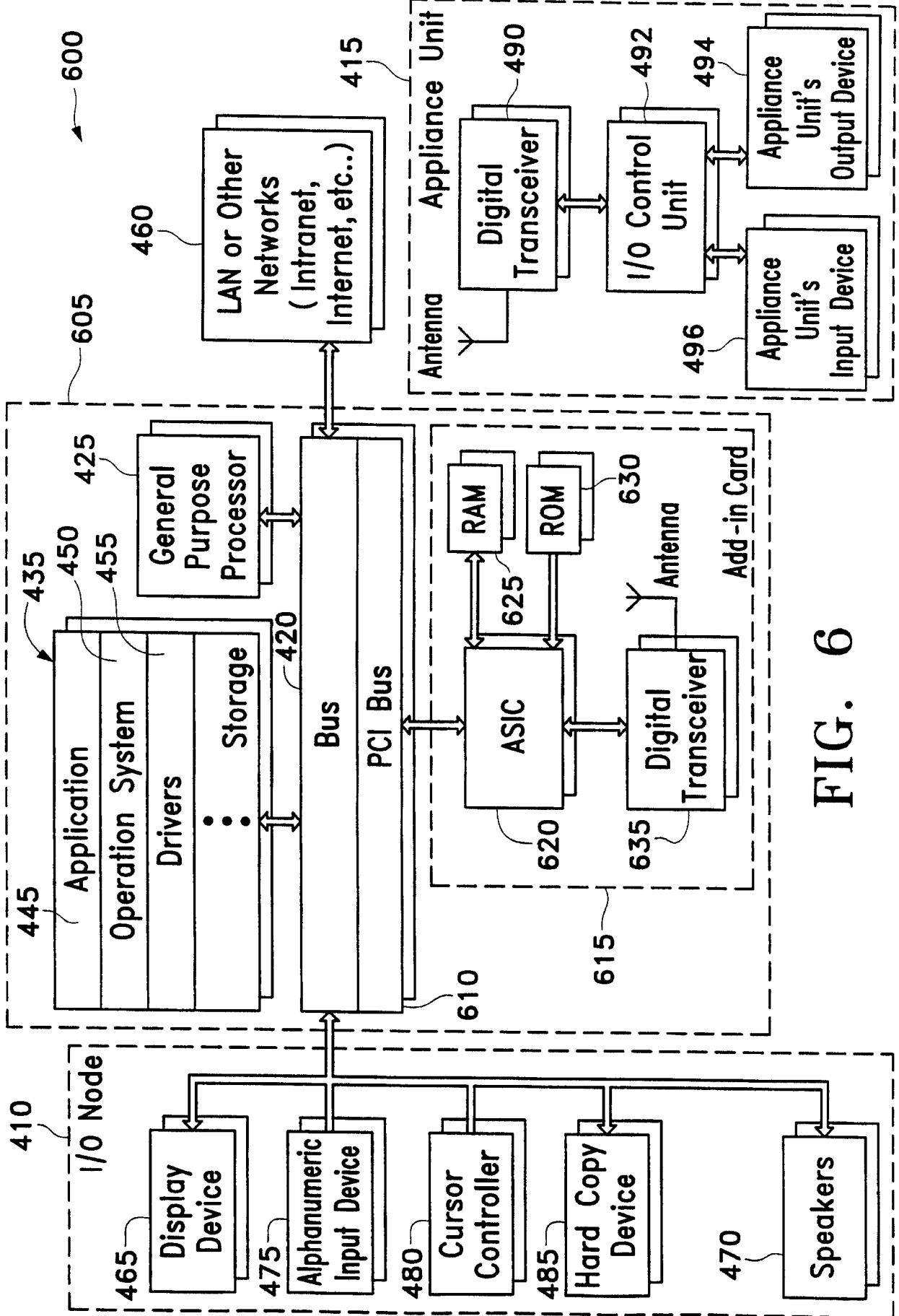

FIG. 6

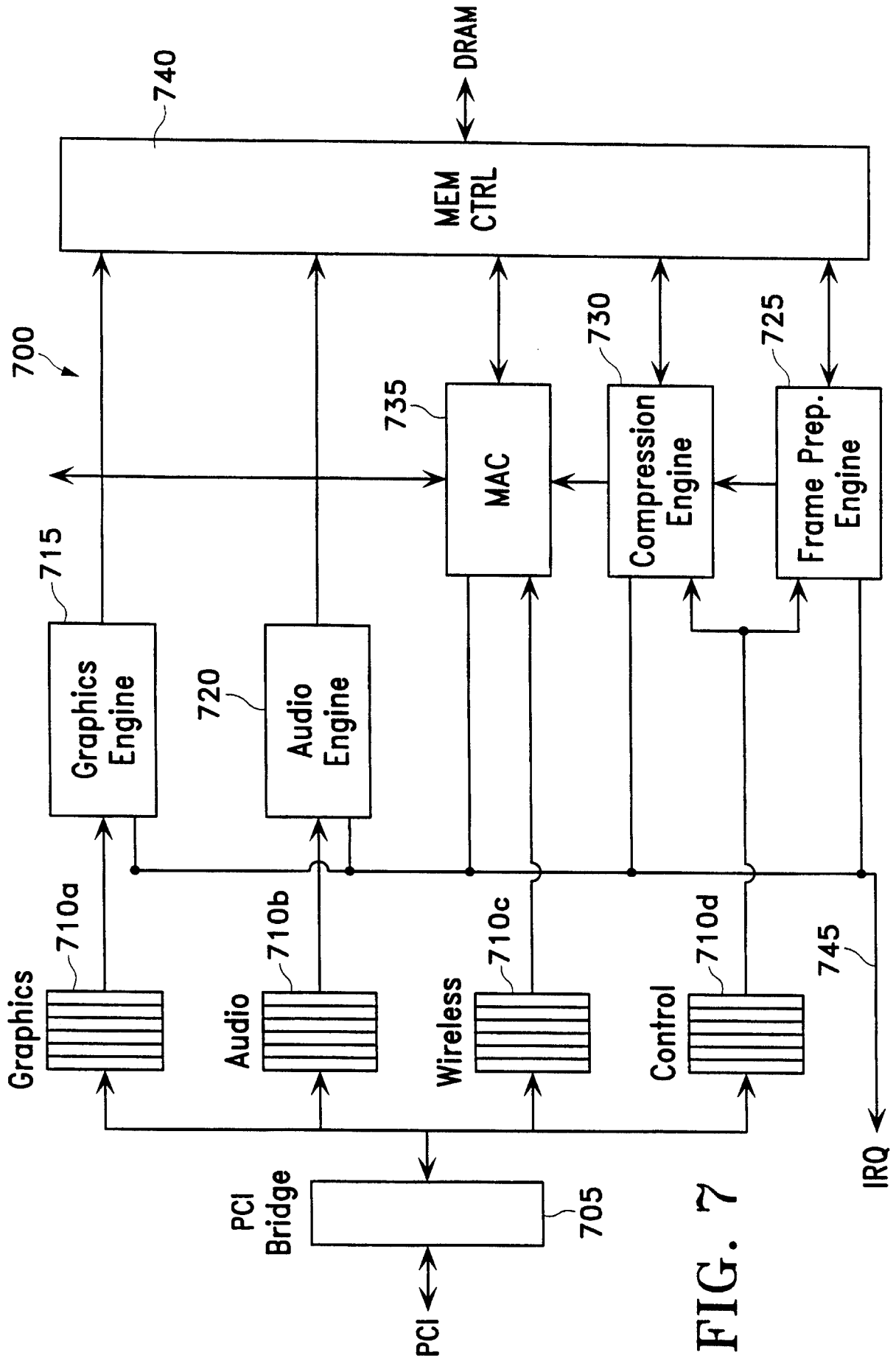

FIG. 7

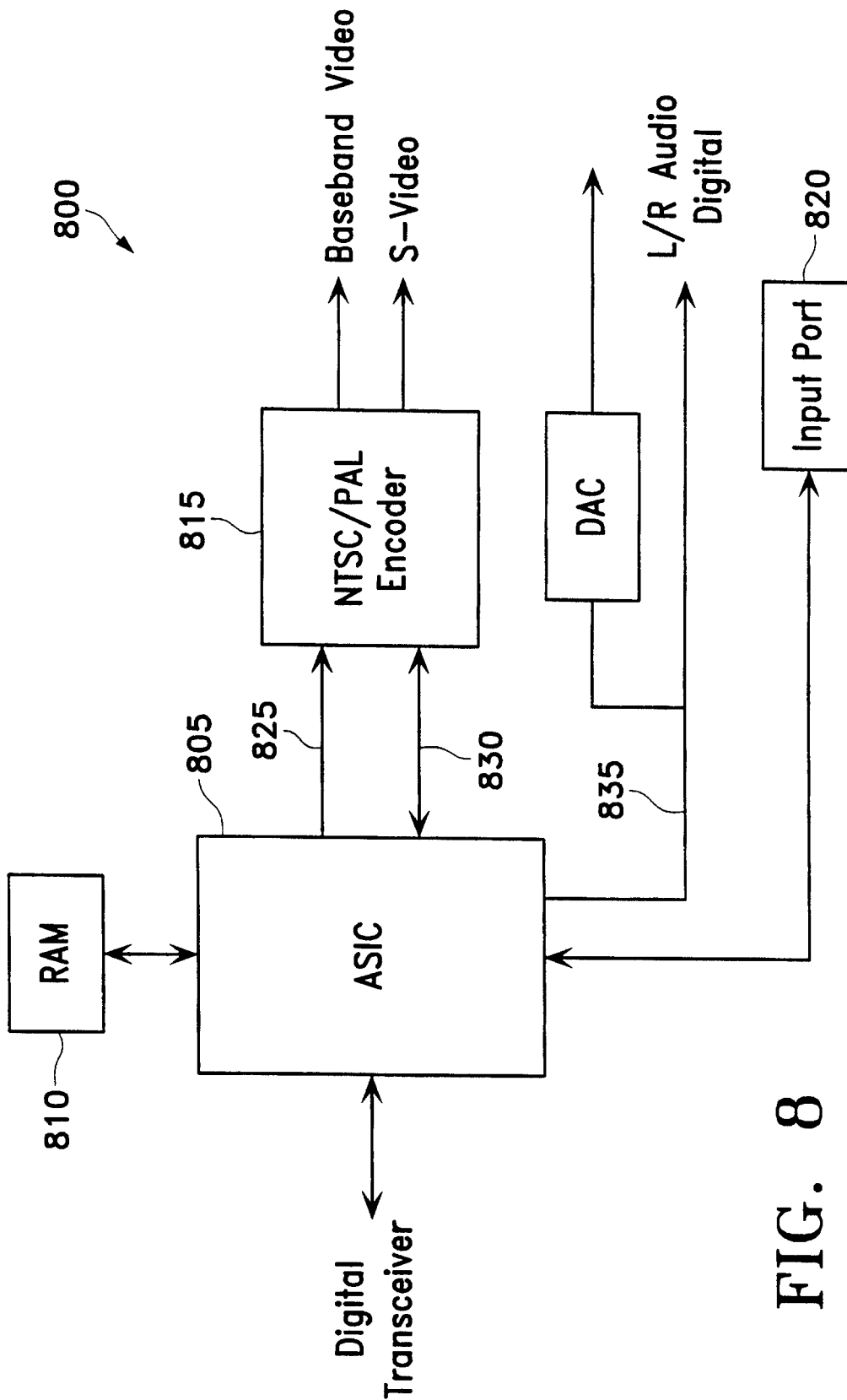

FIG. 8

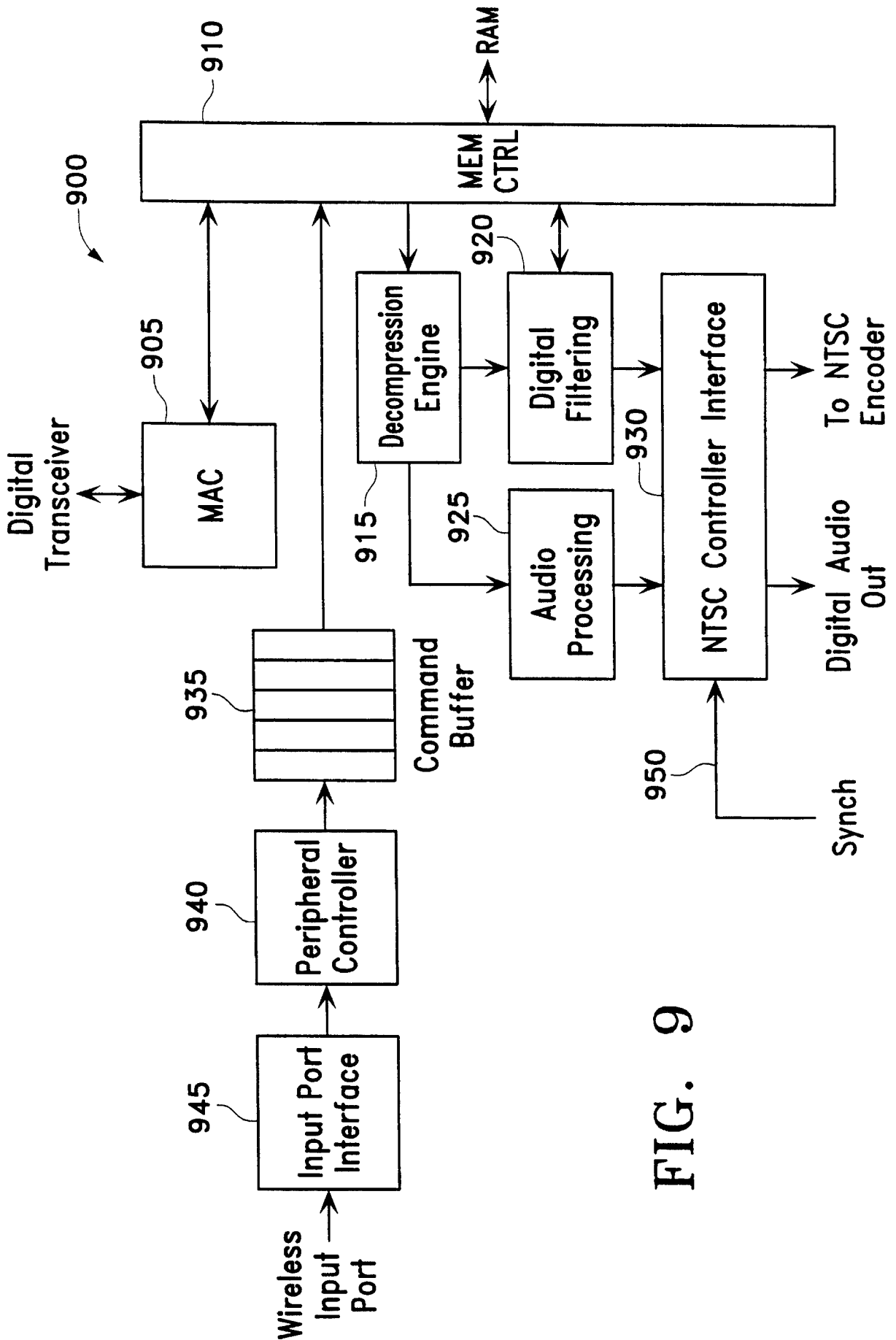

FIG. 9

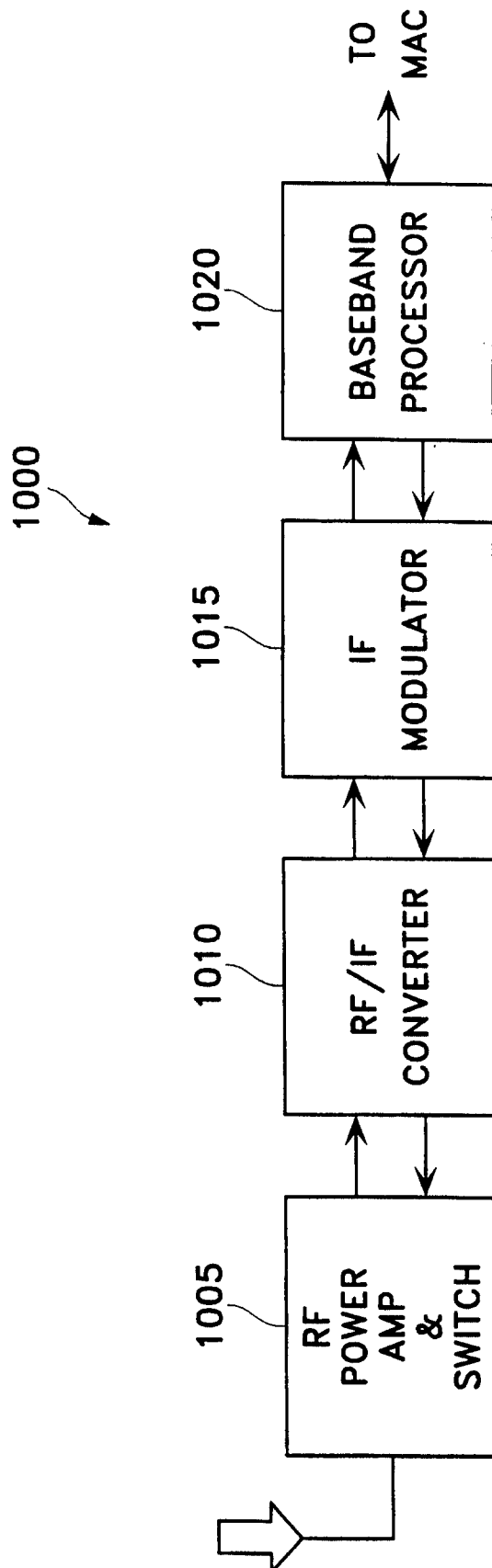

FIG. 10

11/13

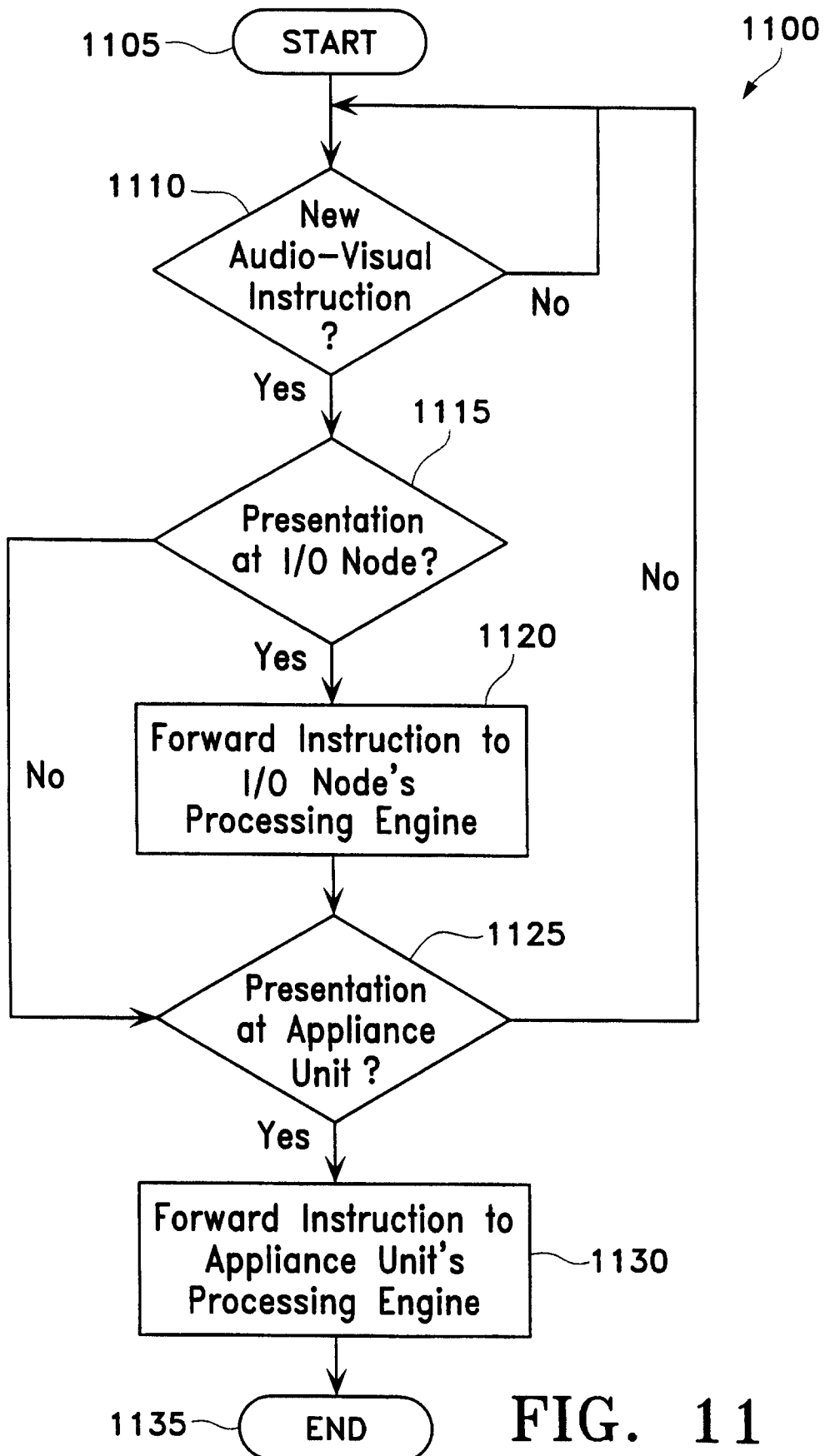

FIG. 11

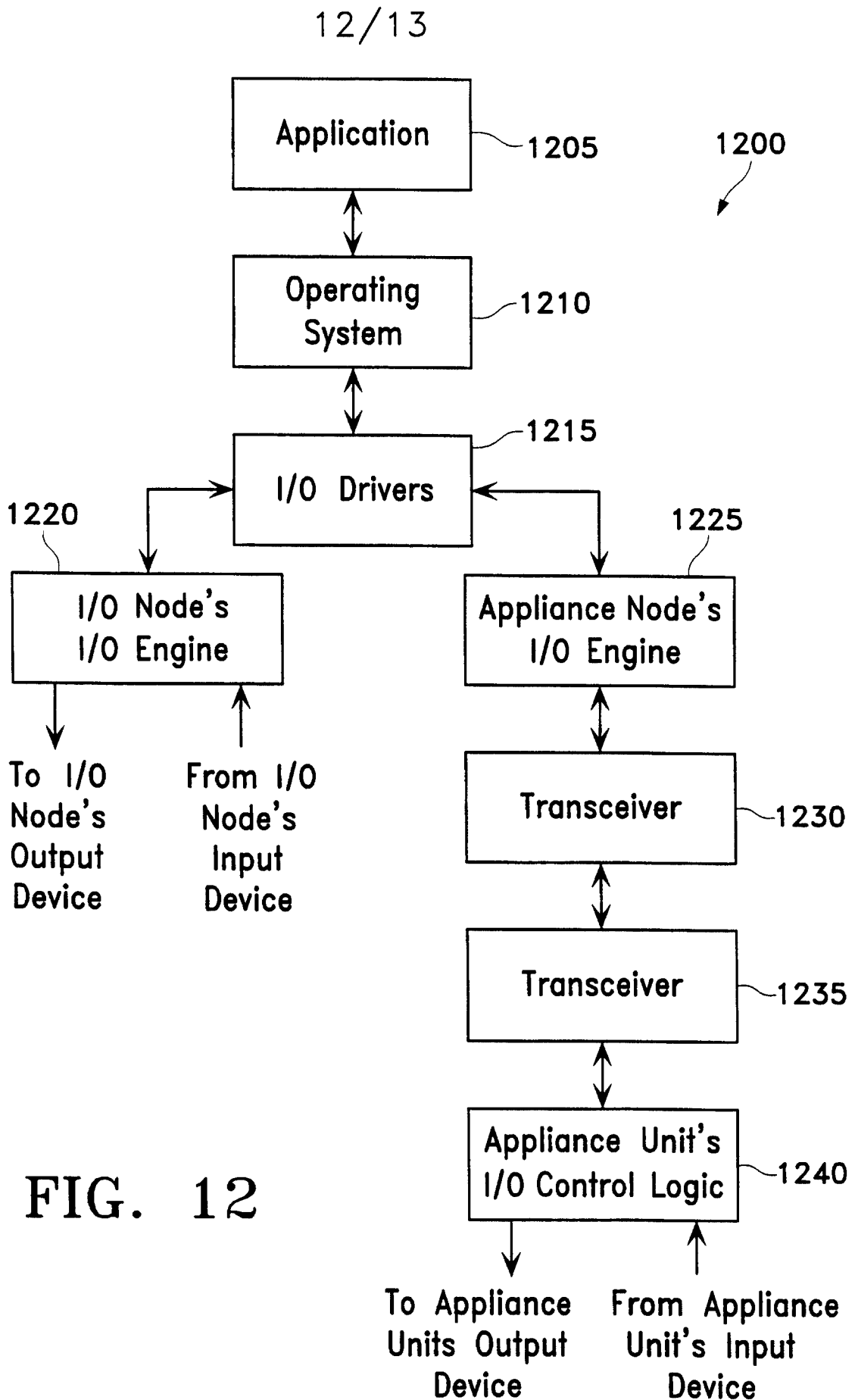

FIG. 12

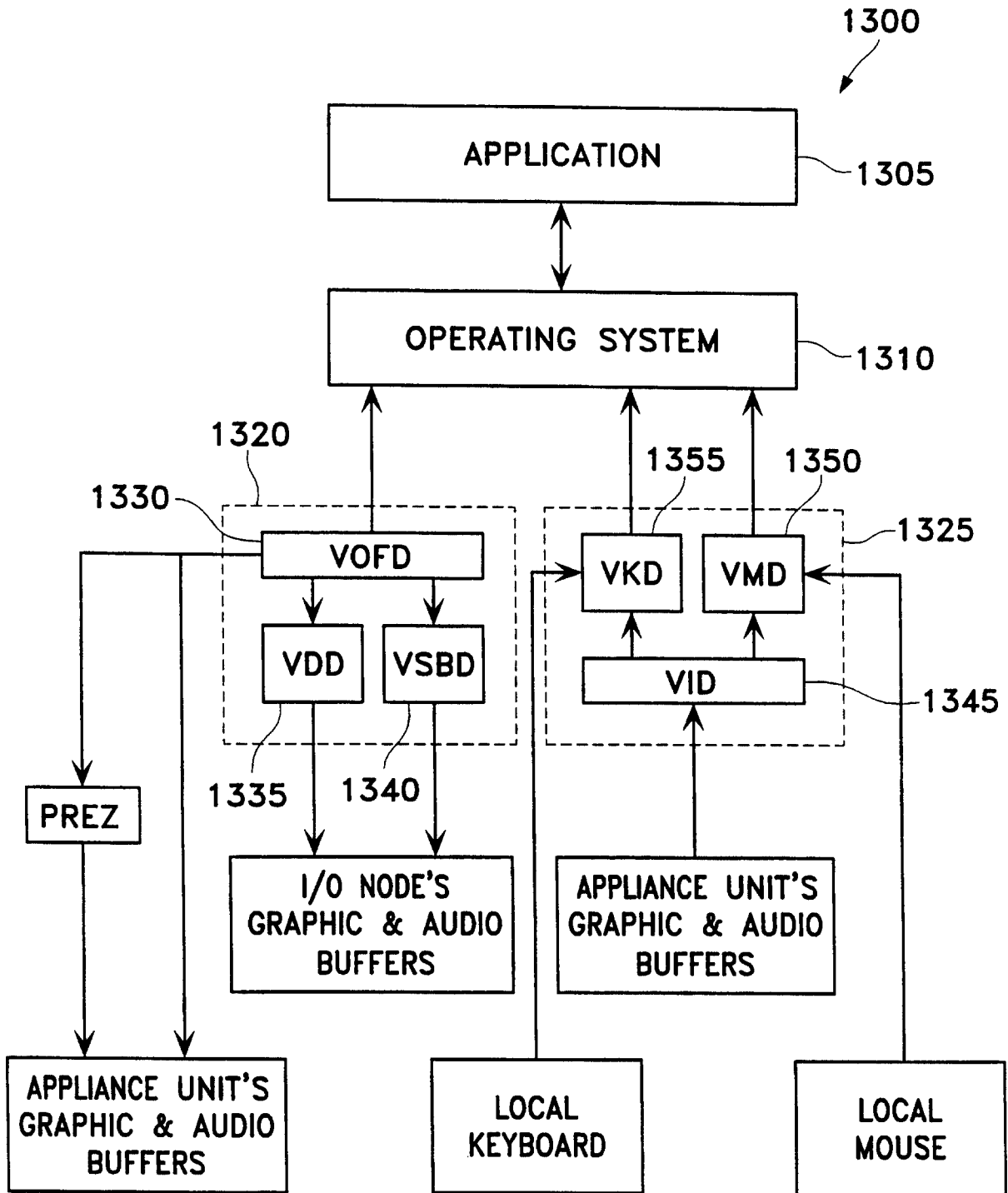

FIG. 13

