

N. S. O'NEALL. CYLINDRICAL TRUNK.

No. 546,429.

Patented Sept. 17, 1895.

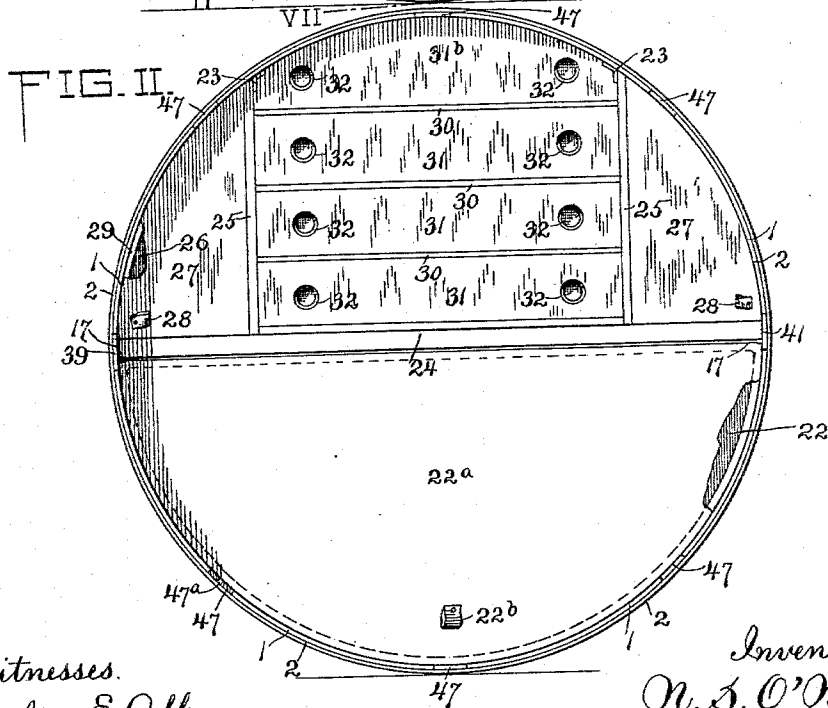
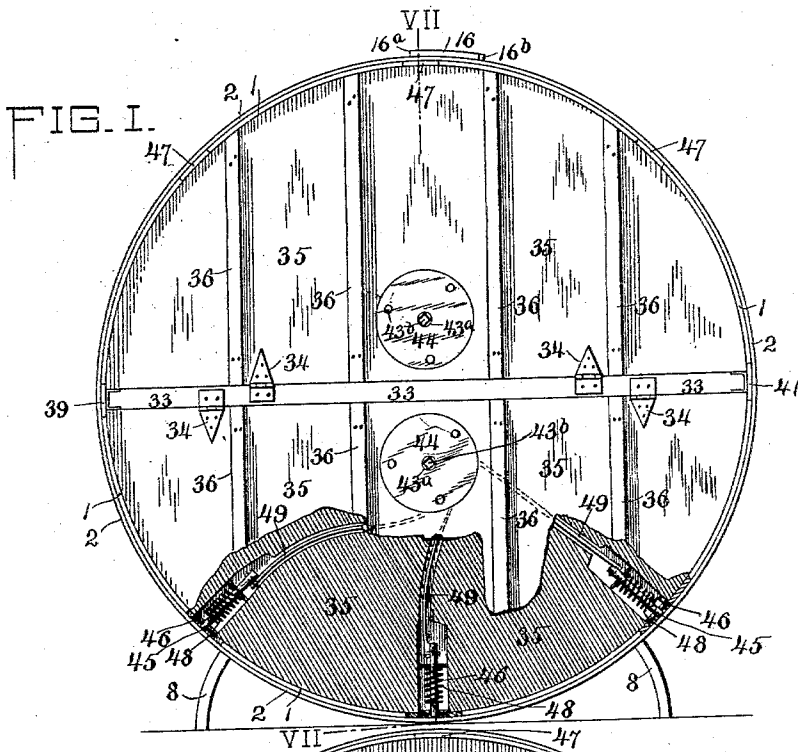

Witnesses.
 Walter E. Allen.
 Walter Allen

Inventor.
 N. S. O'Neill.
 By Knight & Co.
 Attys.

N. S. O'NEALL.
CYLINDRICAL TRUNK.

No. 546,429.

Patented Sept. 17, 1895.

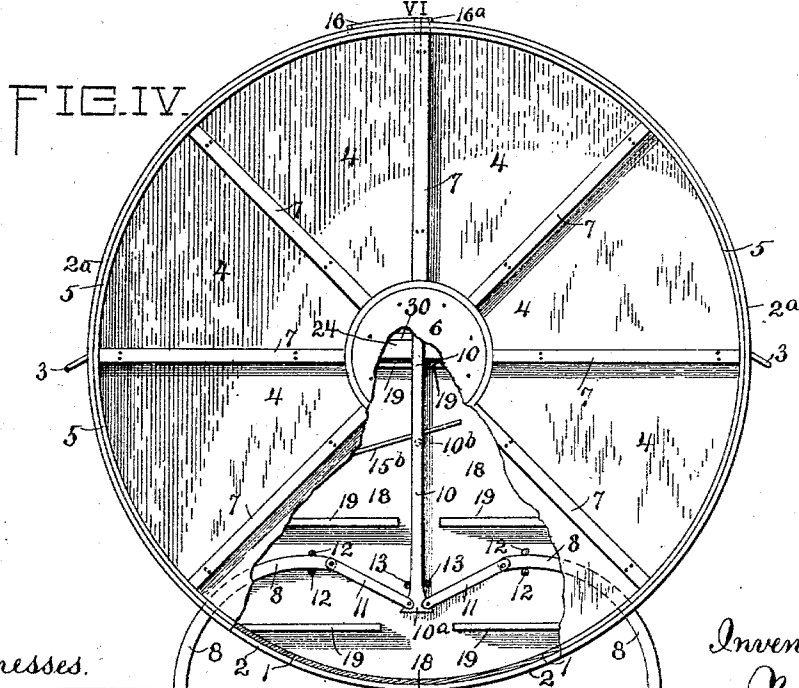
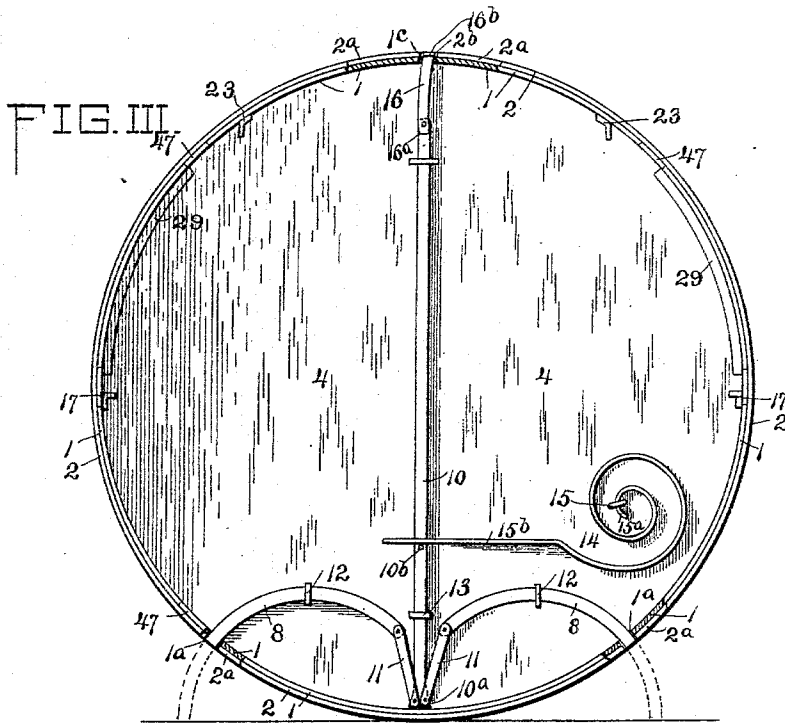

Witnesses:
 Walter E. Allen.
 Walter Allen

Inventor:
 N. S. O'Neill.
 By Knight Bros
 Atty.

N. S. O'NEALL. CYLINDRICAL TRUNK.

No. 546,429.

Patented Sept. 17, 1895.

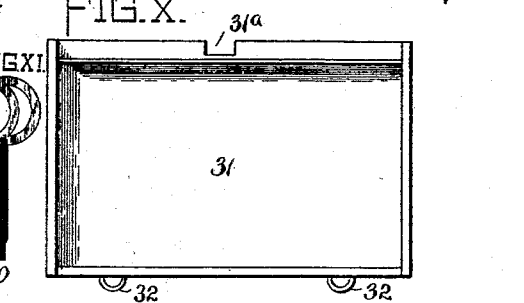
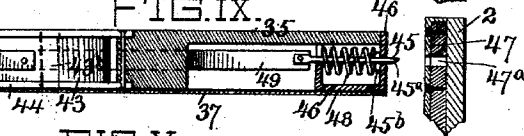
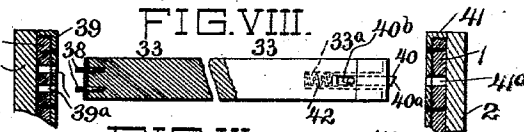
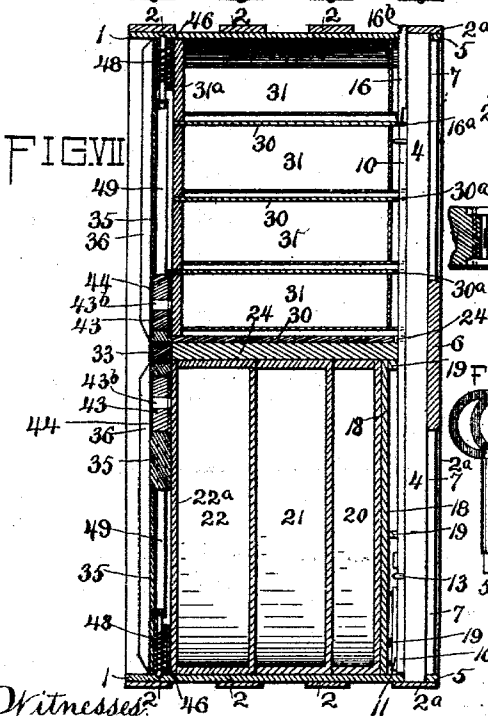
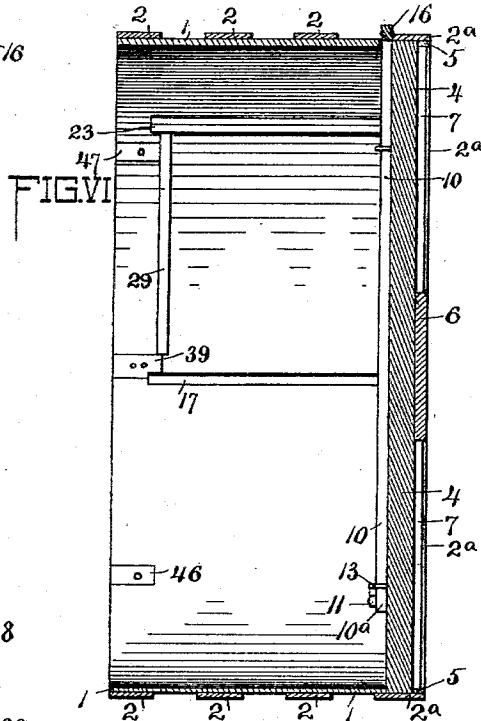
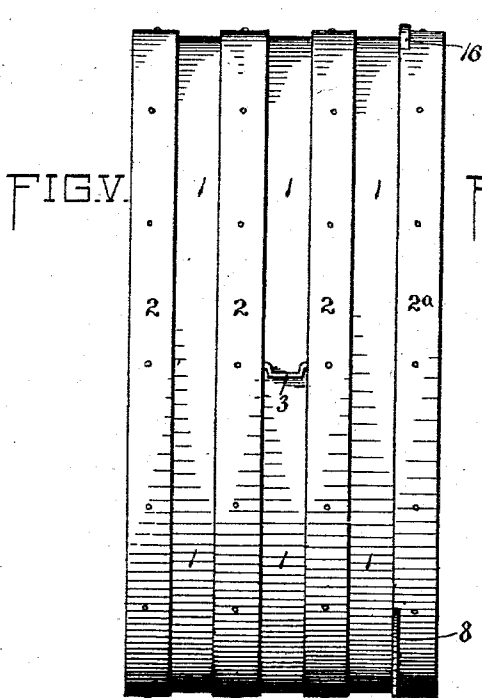

Witnessed
 Walter E. Allen.
 Walter Allen.

Inventor.
 N. S. O'Neall.
 By Knight Bros.
 Attys

UNITED STATES PATENT OFFICE.

NATHANIEL STRONG O'NEALL, OF CUMBERLAND, MARYLAND.

CYLINDRICAL TRUNK.

SPECIFICATION forming part of Letters Patent No. 546,429, dated September 17, 1895.

Application filed January 7, 1895. Serial No. 834,068. (No model.)

To all whom it may concern:

Be it known that I, NATHANIEL STRONG O'NEALL, a citizen of the United States, and a resident of Cumberland, in the county of Allegany and State of Maryland, have invented certain new and useful Improvements in Cylindrical Trunks, of which the following is a specification.

My invention relates to improvements in cylindrical or rolling trunks; and it consists in novel features of construction hereinafter described and claimed.

In order that my invention may be fully understood, I will proceed to describe it with reference to the accompanying drawings, in which—

Figure I is a front elevation of my improved cylindrical trunk in rolling position having a portion of the head or cover broken away to show the spring locking-bolts and keepers for fastening the head or cover to the body of the trunk. Fig. II is a front view of the trunk, the head or cover being removed and a portion of one of the compartment-lids being broken away to show the strip whereby the lid is supported at its outer edge. Fig. III is a front elevation of the casing of the trunk in rolling position, the head or cover being omitted. Fig. IV is a rear elevation of the trunk in rolling position, a portion of the bottom being omitted to show the sliding legs or stays and false bottom. Fig. V is a side elevation of the trunk in rolling position. Fig. VI is an axial section of the casing of the trunk in rolling position on the line VI VI, Fig. IV. Fig. VII is an axial section of the trunk in rolling position on the line VII VII, Fig. I. Fig. VIII is a detail view of the diametrically-arranged strip of the head or cover, partly in side view, and also showing parts of the casing. Fig. IX is a detail view showing a diametric section of the head or cover in line with the locking device, and also showing part of the casing. Fig. X is a plan view of a drawer. Fig. XI is a front elevation of the key for unlocking the lids.

1 is a cylindrical casing of wood, leather, metal, or other suitable material, having circumferential bands 2, of similar material, on which the trunk is rolled from place to place and by which it is braced.

3 represents pivoted handles on opposite

sides of the casing, by which the trunk can be lifted and hoisted. The casing is provided with a bottom 4, held within the inner band 2^a against the inner edge of the casing by means of a circular strip 5, properly secured. The bottom is strengthened and supported by a center piece 6 and radial battens 7, extending from the center piece to the circular strip and properly fastened to the bottom. As means for preventing the rolling of the trunk when in place, I provide the same with a pair of curved sliding legs or stays 8, projected through openings 1^a in the casing by means of a sliding diametrically-arranged pull bar or rod 10, having its head 10^a connected with the inner ends of the legs or stays by means of pivoted links 11. The legs are guided and held against the bottom by staples or straps 12, and the bar or rod is guided and held against the bottom by staples or straps 13. For holding the legs or stays and the pull bar or rod in their normal position within the casing I employ a helical spring 14, secured to the bottom by a staple or strap 15 at its inner end 15^a and having its outer free end 15^b bearing on a pin 10^b, located on the pull bar or rod for pressing the latter inward. To throw out or project the legs or stays I employ a draw-bar 16, pivoted to the outer end of the pull bar or rod extending through the opening 1^a in the casing and seating in a recess 2^b in the band 2^a and folded down against the casing when drawn out. The draw-bar is provided with an inner shoulder 16^a, which catches against one side of the opening when folded down, so as to hold the pull bar or rod against the action of the spring when the legs or stays are thrown out. The draw-bar is also provided with a handle 16^b, by which it is grasped and lifted, and which normally bears on the casing. 17 are a pair of right-angled plates secured by one side at diametrically-opposite points to the inside of the casing. Between the inner side of these angle-plates and the casing is a removable semi-circular false bottom 18, having distance cleats 19 and providing a floor to protect the legs or stay-links and the spring, together with the inner end of the pull bar or rod. Located on and over the false bottom are a series of semi-circular independently removable trays 20, 21, and 22, having their corners recessed to fit into the right-angled strips, and of varying

depths, the top tray being provided with a lid 22^a, having hand-loops 22^b for lifting it. These drawers form receptacles in one half of the casing parallel with the bottom. The other half of the casing is arranged as now described.

23 represents a pair of obtuse-angled plates secured by one side to the casing at points intermediate of the draw-bar opening and the right-angled plates. Secured between the obtuse-angled plates on the one side and the right-angled plates on the other side is a removable closely-fitting semicircular frame consisting of a diametrically-arranged division-board 24, having a recess 24^a for the pull bar or rod, and transverse division-boards 25, forming segmental compartments 26 between the frame and the casing guarded by lids 27, having hand-loops 28 and hinged to the transverse division-boards. These lids are supported at their free edges against curved strips 29, secured to the casing. Between the transverse division-boards are a series of shelves 30, having recesses 30^a for the pull bar or rod. 31 are series of drawers located on the shelves provided with pivoted folding handles 32 and having recesses 31^a for the pull bar or rod. The upper drawer has a segmental top 31^b and has its sides recessed to fit the obtuse-angled plates. The whole is closed by a removable head or cover constructed as will now be described.

33 is a diametrically-arranged strip having suitable locking devices and forming the central piece for securing the frame in place, and to which are secured by means of hinges 34 a pair of semicircular lids 35, having strengthening transverse battens 36, suitable locking devices, and lining 37, concealing the locking devices. The devices for locking the strip of the head or cover consist of superposed spurs 38, projecting from one end of the strip which enters superposed orifices 39^a, formed in a keeper-plate 39 at one side of the casing, and a bolt 40, located in a cavity 33^a at the other end of the strip formed with a beveled end 40^a, adapted to engage an orifice 41^a in a keeper-plate 41, secured to the other side of the casing. The bolt is provided with a cross-pin 40^b, by which it is retracted and limited in its movement. A spring 42 is located in the cavity in rear of the bolt for the purpose of pressing it outward to cause the bolt to enter its orifice when the strip is placed in position and the studs entering their orifices and the bolt end of the strip forced down on the keeper-plate when the spring will yield sufficiently to permit the beveled end of the bolt to slide down its keeper-plate into its orifice. The devices for locking the lids of the head or cover when the strip is secured consist of a pair of wheels or drums 43, located at the inner edges of the lids adjacent to the strip, having hubs 43^a, provided with keyholes 43^b and journaled in bearing-plates 44, securely fixed in the lids by suitable fastenings.

45 represents bolts sliding in boxes 46, located in the outer edges of the lids and having bevel ends 45^a, which enter orifices 47^a of keeper-plates 47, secured to the casing when the lids are closed. These bolts are forced outward by springs 48, located in the boxes and bearing against the inner ends of the boxes and against cross-pins 45^b, projecting from the sides of the bolts. The bolts are retracted by means of the wheels or drums connected to the bolts by curved flexible rods 49, lapping around the wheels or drums.

50 is the key for engaging the keyholes in the hubs of the wheels or drums for rotating the latter to withdraw or retract the bolts.

Having thus described my invention, the following is what I claim as new and desire to secure by Letters Patent:

1. A cylindrical trunk constructed with a casing 1, a bottom 4, a pair of curved sliding legs 8, the diametrically arranged pull-bar 10, and means for operating the pull-bar for projecting and retracting the legs; substantially as described.

2. A cylindrical trunk comprising a casing 1, a bottom 4, a pair of curved sliding legs 8, the pull-bar 10, the pivoted links 11, connecting the legs with the pull-bar, a spring for holding the latter in normal position, a draw-bar 16, secured to the outer end of the pull-bar, and means for holding the pull-bar against the action of the spring; substantially as described.

3. The combination of the cylindrical casing 1, a bottom 4, a pair of sliding legs 8, the pull-bar 10, the pivoted links 11, the spring connected with the pull-bar, the angle plates 17 secured to the inside of the casing at diametrically opposite points, and the semi-circular false bottom 18 having distance cleats 19 and providing a floor to protect the legs, links, and the spring, together with the inner end of the pull-bar; substantially as described.

4. The combination of the cylindrical casing 1, a bottom 4, the angle plates 17 secured to the inside of the casing at diametrically opposite points, the semi-circular false bottom 19, the series of semi-circular independently removable trays 20, 21, 22, located on and over the false bottom and fitting between the angle plates and the casing, and the head having a diametrically arranged strip 33, semi-circular lids 35 and suitable locking devices; substantially as described.

5. The combination of the cylindrical casing 1, a bottom 4, the right angle plates 17 secured by one of their sides to the inside of the casing, at diametrically opposite points, the obtuse angle plates 23 secured by one of their sides to the inside of the casing at points at right angles to the right angle plates, the removable closely fitting frame consisting of the diametrically arranged division board 24 and the division boards 25 transverse thereto, forming segmental compartments 26, and the head having a diametrically arranged strip

33, semi-circular lids 35 and suitable locking devices; the frame being secured between the obtuse angle plates on the one side and the right angle plates on the other side, substantially as described.

6. The combination of the cylindrical casing 1, a bottom 4, the removable frame occupying one-half of the casing and consisting of the diametrically arranged division board 24, the transverse division boards 25, forming the segmental compartments 26 having lids 27, and the series of shelves 30 between the transverse division boards, the series of drawers 31; the upper drawer having a segmental top 31^b fitting the casing, and the head having a diametrically arranged strip 33, semi-circular lids 35, and suitable locking devices; substantially as described.

7. The combination of the cylindrical casing 1, a bottom 4, the right angle plates 17, the obtuse angle plates 23, the removable semi-circular false bottom 19, the independently removable semi-circular trays 20, 21, 22 located on and over the false bottom, the removable frame occupying one-half of the casing consisting of the division board 24, the division boards 25, transverse thereto, forming segmental compartments 26, and the series of shelves 30; substantially as described.

8. The combination of the cylindrical casing 1, a bottom 4, the removable head comprising the diametrically arranged strip 33 having suitable locking devices at its ends and forming a central piece, and the semi-cir-

cular lids 35 hinged to the strip, and having suitable locking devices, and the semi-circular frame and the independently removable semi-circular trays, on which the head rests; substantially as described.

9. The combination of the cylindrical casing 1, a bottom 4, the removable head comprising the diametrically arranged strip 33, having the spurs 38 projecting from one end thereof and engaging orifices in the casing and the sliding bolt 40 located at the other end of the strip, and engaging an orifice in the casing, and the semi-circular lids 35 hinged to the strip and having suitable locking devices, and the semi-circular frame and independently removable semi-circular trays on which the head rests; substantially as described.

10. The combination of the cylindrical casing 1, a bottom 4, and the removable head comprising the diametrically arranged strip 33, having suitable locking devices, and the semi-circular lids 35, hinged to the strip and each having locking devices comprising wheels 43 located at the inner edge of the lid, having a hub 43^a provided with a key-hole 43^b sliding spring bolts 45 engaging orifices in the casing and the curved flexible rods 49 lapping around and connecting the wheel with the bolts; substantially as described.

NATHANIEL STRONG O'NEALL.

Witnesses:

F. M. OFFUTT,
J. WILSON HUMBUD.