

(19) World Intellectual Property Organization
International Bureau



(43) International Publication Date
21 June 2007 (21.06.2007)

PCT

(10) International Publication Number
WO 2007/070738 A2

(51) International Patent Classification:
A63F 9/24 (2006.01)

(21) International Application Number:
PCT/US2006/061056

(22) International Filing Date:
17 November 2006 (17.11.2006)

(25) Filing Language: English

(26) Publication Language: English

(30) Priority Data:
11/302,511 12 December 2005 (12.12.2005) US

(71) Applicant (for all designated States except US): SONY
COMPUTER ENTERTAINMENT INC. [JP/JP]; 2-6-21
Minami-Aoyama, Minato-ku, Tokyo 107-0062 (JP).

(72) Inventors; and

(75) Inventors/Applicants (for US only): MARKS, Richard,
L. [US/US]; 919 East Hillsdale Blvd., 2nd Floor, Foster
City, CA 94404 (US). DESHPANDE, Hrishikesh, R.
[IN/US]; 919 East Hillsdale Blvd., 2nd Floor, Foster City,
CA 94404 (US).

(74) Agent: ISENBERG, Joshua, D.; JDI Patent, 809 Corporate
Way, Fremont, CA 94539 (US).

(81) Designated States (unless otherwise indicated, for every
kind of national protection available): AE, AG, AL, AM,
AT, AU, AZ, BA, BB, BG, BR, BW, BY, BZ, CA, CH, CN,
CO, CR, CU, CZ, DE, DK, DM, DZ, EC, EE, EG, ES, FI,
GB, GD, GE, GH, GM, GT, HN, HR, HU, ID, IL, IN, IS,
JP, KE, KG, KM, KN, KP, KR, KZ, LA, LC, LK, LR, LS,
LT, LU, LV, LY, MA, MD, MG, MK, MN, MW, MX, MY,
MZ, NA, NG, NI, NO, NZ, OM, PG, PH, PL, PT, RO, RS,
RU, SC, SD, SE, SG, SK, SL, SM, SV, SY, TJ, TM, TN,
TR, TT, TZ, UA, UG, US, UZ, VC, VN, ZA, ZM, ZW.

(84) Designated States (unless otherwise indicated, for every
kind of regional protection available): ARIPO (BW, GH,
GM, KE, LS, MW, MZ, NA, SD, SL, SZ, TZ, UG, ZM,
ZW), Eurasian (AM, AZ, BY, KG, KZ, MD, RU, TJ, TM),
European (AT, BE, BG, CH, CY, CZ, DE, DK, EE, ES, FI,
FR, GB, GR, HU, IE, IS, IT, LT, LU, LV, MC, NL, PL, PT,
RO, SE, SI, SK, TR), OAPI (BF, BJ, CF, CG, CI, CM, GA,
GN, GQ, GW, ML, MR, NE, SN, TD, TG).

Published:

— without international search report and to be republished
upon receipt of that report

For two-letter codes and other abbreviations, refer to the "Guidance
Notes on Codes and Abbreviations" appearing at the beginning
of each regular issue of the PCT Gazette.

(54) Title: METHODS AND SYSTEMS FOR ENABLING DEPTH AND DIRECTION DETECTION WHEN INTERFACING
WITH A COMPUTER PROGRAM

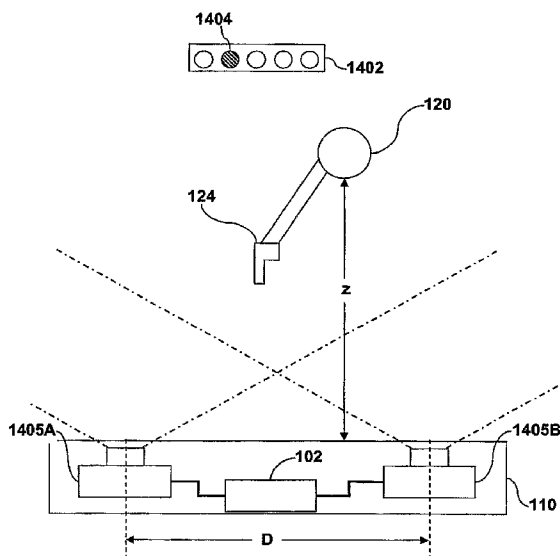

(57) Abstract: A method for detecting direction when interfacing with a computer program is provided. The method includes capturing an image presented in front of an image capture device. The image capture device has a capture location in a coordinate space. When a person is captured in the image, the method includes identifying a human head in the image and assigning the human head a head location in the coordinate space. The method also includes identifying an object held by the person in the image and assigning the object an object location in coordinate space. The method further includes identifying a relative position in coordinate space between the head location and the object location when viewed from the capture location. The relative position includes a dimension of depth. The method may be practiced on a computer system, such as one used in the gaming field.

WO 2007/070738 A2

**METHODS AND SYSTEMS FOR ENABLING DEPTH AND
DIRECTION DETECTION WHEN INTERFACING WITH A
COMPUTER PROGRAM**

5

CLAIM OF PRIORITY

This application is a continuation in part of US Patent Application No. 10/663,236, entitled "METHOD AND APPARATUS FOR ADJUSTING A VIEW OF A SCENE
10 BEING DISPLAYED ACCORDING TO TRACKED HEAD MOTION", filed on September 15, 2003, is hereby incorporated by reference. This application is also a continuation in part of US Patent Application No. 10/759,782, entitled "METHOD AND APPARATUS FOR LIGHT INPUT DEVICE", filed on January 16, 2004, and is hereby incorporated by reference. This application is also related to US Patent Application No.
15 11/301,673 , entitled "METHODS AND SYSTEMS FOR ENABLING DIRECTION DETECTION WHEN INTERFACING WITH A COMPUTER PROGRAM" to inventors Richard L. Marks and Hrishikesh R. Deshpande (Attorney Docket SONYP051), which is filed concurrently herewith and is incorporated herein by reference.

BACKGROUND

20 **Description of the Related Art**

[0001] The video game industry has seen many changes over the years. As computing power has expanded, developers of video games have likewise created game software that takes advantage of these increases in computing power. To this end, video game developers have been coding games that incorporate sophisticated operations and mathematics to
5 produce a very realistic game experience.

[0002] Examples of gaming platforms include the Sony Playstation or Sony Playstation2 (PS2), each of which is sold in the form of a game console. As is well known, the game console is designed to connect to a monitor (usually a television) and enable user interaction through handheld controllers. The game console is designed with specialized processing
10 hardware, including a CPU, a graphics synthesizer for processing intensive graphics operations, a vector unit for performing geometry transformations, and other glue hardware, firmware, and software. The game console is further designed with an optical disc tray for receiving game compact discs for local play through the game console. Online gaming is also possible, where a user can interactively play against or with other users over the
15 Internet.

[0003] As game complexity continues to intrigue players, game and hardware manufacturers have continued to innovate to enable additional interactivity. In reality, however, the way in which users interact with a game has not changed dramatically over the years. Commonly, users still play computer games using hand held controllers or interact
20 with programs using mouse pointing devices.

[0004] In view of the foregoing, there is a need for methods and systems that enable more advanced user interactivity with game play.

SUMMARY OF THE INVENTION

[0005] Broadly speaking, the present invention fills these needs by providing an apparatus and method that facilitates interactivity with a computer program. In one embodiment, the computer program is a game program, but without limitation, the apparatus and method can find applicability in any consumer electronic device that will require a user to interact therewith. The present invention simplifies user interaction experience through machine recognizable gestures based on pointing to the interface and discriminating commands based on factors including trigger cues and position determination of a hand or object under user control.

[0006] In one embodiment, a method for detecting direction when interfacing with a computer program is described. The method includes capturing an image presented in front of an image capture device. The image capture device has a capture location in a coordinate space. When a person is captured in the image, the method includes identifying a human head in the image and assigning the human head a head location in the coordinate space. The method also includes identifying an object held by the person in the image and assigning the object an object location in coordinate space. The method further includes identifying a relative position in coordinate space between the head location and the object location when viewed from the capture location. The relative position includes a dimension of depth. This dimension of depth may be determined stereoscopically through use of two cameras or through the use of sound location techniques or by combination thereof.

[0007] In another embodiment, a method for detecting pointing direction of an object directed toward a display screen that can render graphics of a computer program is provided. The method includes capturing an image presented in front of an image capture device. The image capture device has a capture location in a coordinate space that is proximate to the display screen. When a person is captured in the image, the method includes identifying a first body part of the person in the image and assigning the first body part a first location in the coordinate space. Then the method includes identifying a second body part of the person in the image and assigning the second body part a second location in coordinate space. Once the first and second body parts are identified, the method moves to identifying a relative position in coordinate space between the first location and the second location when viewed from the capture location. The relative position includes a dimension of depth which may be determined, e.g., stereoscopically through use of two cameras, through the use of sound location techniques or through a combination thereof.

[0008] In one embodiment, an apparatus for capturing image and sound during interactivity with a computer program is provided. The apparatus includes an image capture unit that is configured to capture one or more image frames. These image frames are analyzed to identify a person's head and a person's hand. Based on the relative positioning of the hand and head, the apparatus can ascertain a pointing direction, which may be translated as the pointing location on a display screen.

[0009] Other aspects and advantages of the invention will become apparent from the following detailed description, taken in conjunction with the accompanying drawings, illustrating by way of example the principles of the invention.

BRIEF DESCRIPTION OF THE DRAWINGS

[0010] The invention, together with further advantages thereof, may best be understood by reference to the following description taken in conjunction with the accompanying drawings.

5 [0011] Figure 1A and 1B illustrate the environment of one embodiment of present invention, which takes advantage of the pointing direction determination described herein.

[0012] Figures 2-4 illustrate the analysis of the relative positions between a person's head and a person's hand (or object held by the person), when determining pointing direction.

[0013] Figures 5A-5C illustrate tracking and triggering embodiments, which can be
10 identified by the computer program by the analysis of the captured image data, in accordance with one embodiment of the present invention.

[0014] Figures 6A-6F illustrate alternate embodiments of detecting an object and detecting changes in the object based on relative orientation of the object itself, in accordance with one embodiment of the present invention.

15 [0015]]Figures 7 and 8A-8B illustrate examples of hand positions, when the hand positions and shapes are analyzed to determine a desired trigger or tracking response by the computer program, in accordance with one embodiment of the present invention.

[0016] Figures. 9 and 10 provide exemplary flow charts of the operations that can be executed in determining a pointing direction, in accordance with one embodiment of the
20 present invention.

[0017] Figures 11 and 12 provide exemplary embodiments of hardware that may be used in processing the computer code necessary to execute the claimed operations, in accordance with one embodiment of the present invention.

[0018] Figures 13A-13C illustrate embodiments for when depth information is considered
5 when identifying objects to track, when interfacing with a system that needs to ascertain pointing direction, in accordance with one embodiment of the present invention.

[0019] Figures 14A-14C illustrate an embodiment of the invention wherein stereoscopic techniques are used to determine an object's depth.

[0020] Figures 15A-15B illustrate an image capture device including adapted to determine
10 the depth of an object using sound location.

[0021] Figure 15C illustrates an interactive game setup that utilizes sound location to determine the depth of an object.

DETAILED DESCRIPTION

[0022] In the following description, numerous specific details are set forth in order to provide a thorough understanding of the present invention. It will be apparent, however, to one skilled in the art that the present invention may be practiced without some or all of these
5 specific details. In other instances, well known process steps have not been described in detail in order not to obscure the present invention.

[0023] Figure 1A illustrates an interactive game setup 100, in accordance with one embodiment of the present invention. The interactive game setup 100 includes a computer 102 that is coupled to a display screen 110. An image capture device 105 is placed on top of
10 the display screen 110 and is coupled to the computer 102. Computer 102 is, in one embodiment, a gaming system console which allows users to play video games and interface with the video games through controllers 108. The image capture device 105 is shown placed on top of the display screen 110, but it should be understood that the image capture device 105 can be placed in any other proximate location that will allow it to capture images
15 that are located about in front of the display screen 110. Techniques for capturing these movements and interactions can vary, but exemplary techniques are described in United Kingdom Applications GB 0304024.3 (PCT/GB2004/000693) and GB 0304022.7 (PCT/GB2004/000703), each filed on February 21, 2003, and each of which is hereby incorporated by reference.

20 [0024] In a specific example, but not limited to any brand, the game console can be a one manufactured by Sony Computer Entertainment Inc., Nintendo, Microsoft, or any other manufacturer. The image capture device 105 can be as simple as a standard web cam or can include more advanced technology. In one embodiment, the image capture device should be

capable of capturing images, digitizing the images, and communicating the image data back to the computer 102. In some embodiments, the image capture device will have logic integrated therein for performing the digitizing and another embodiment the image capture device 105 will simply transmit the captured data back to the computer 102 for digitizing.

5 In either case, the image capture device 105 is capable of capturing either color or black and white images of any object located in front of the image capture device 105.

[0025] Figure 1B illustrates an exemplary embodiment of the present invention in which the computer 102 processes image data provided by the image capture device 105 to ascertain a pointing direction of an object placed in front of the image capture device 105.

10 As shown, the computer 102 is connected to the image capture device 105. The image capture device 105 is designed to focus onto a capture region 105a. In this example, a person 112 is intending to interact with a computer program being executed by the computer 102. The computer program, in this example, is a video game which is rendered and displayed by the display screen 110.

15 [0026] For example purposes only, the video game is a target shooting game in which the person 112 wishes to aim at a target and earn points commensurate with his or her performance. As illustrated on the display screen 110, an image 112' of the person 112 may also be placed on the display screen 110 during game play. Alternatively, the person's image 112' may be omitted from the display screen, depending on the particular device
20 under control or game being played. In this example, the user experience may be enhanced by illustrating an image 112' of the person 112 during the target shooting exercise to present more reality during game play. A feature of the target shooting game is the ability for person 112 to point or direct an object 124 at particular interactive graphics on the display screen 110.

[0027] To achieve accurate pointing direction of the object 124, which in this case and for example purposes is a gun, the person 112 will hold the object 124 with his or her hand 122. The hand 122 will be directionally pointed toward the display screen 110. The image capture device 105 will at this point, analyze the digital image capture of the person 112 to

5 determine the location of the person's 112 head 120, and the location of the person's 112 hand 122. As shown, the person's 112 hand is extended in front of his body and the image capture device will identify the object 124 when examining the captured digital image. The captured digital image will also be examined by code executed at the computer 102 to ascertain the location of the person's 112 head 120. In one embodiment, head tracking is

10 completed with a combination of a template matching (for speed performance), coupled to a face detection code. The face detection code will essentially identify the location of the user's face by locating the user's eyes and other facial features. For additional information on head and face detection, reference may be made to co-pending US Patent Application No. 10/663,236, entitled "METHOD AND APPARATUS FOR ADJUSTING A VIEW OF A

15 SCENE BEING DISPLAYED ACCORDING TO TRACKED HEAD MOTION", filed on September 15, 2003.

[0028] The object 124 will, in one embodiment, have an identifier which may be color or lights (e.g., light emitting diodes "LEDs") coupled to the object so that the program analyzing the captured digital image will easily identify the location of the object 124. Once

20 the computer program has identified the location of the person's head 120 (H) and the location of the person's hand 122 (h), the computer program will perform computations to determine a relative angle from the image capture device position, and between the detected object 124, and the head 120.

[0029] As illustrated in Figure 1B, the relative position of the object 124 and the head 120 will be calculated relative to the image capture device 105. This will produce two angle parameters (theta θ and phi ϕ). The azimuth angle θ will define the horizontal positioning between the head 120 and the object 124 along an X axis. The phi angle ϕ will produce the altitude angle which is the relative angle between the height of the head 120 and the height of the hand 122. In one embodiment, an initial calibration operation may be performed before a gaming operation begins to calibrate the object's pointing location on the display screen 110. For instance, the user may be prompted to calibrate the pointing algorithm by having the user point the object 124 at a specific location on the display screen 110. Once the calibration has been completed, the computer 102 will be able to calculate the azimuth angle and the altitude angle (theta and phi) which define the relative positions of the person's head 120 and the person's hand 122, for each successive frame being captured by the image capture device 105. The relative positioning between the head and the hand may be calculated for each captured frame or may be captured every other frame, or after a number of frames are captured, depending on the accuracy required for the pointing operation. For example, if the game is a shooting gallery game, it would be important for the relative positioning of the head 120 and the hand 122 to be computed for each frame so that the person 112 will have accurate aiming and triggering capabilities when attempting to secure a good performing score in the video game contest.

[0030] Figure 2 illustrates a top view of the person 112 who is positioned in front of the display screen 110, in accordance with one embodiment of the present invention. In this example, an initial azimuth angle (theta₁) is shown being determined as the relative angle between the position of the hand 122 (which is holding object 124), and the head 120. The person 112, during interactive play with the computer program, will be facing the display

screen 110 and most likely, will maintain his body substantially parallel to the display screen 110. When the person 112 maintains his body substantially parallel to the display screen 110, movement of the hand 122 in direction 123 will cause the azimuth angle to be recomputed and produce a new azimuth angle θ_2 .

5 [0031] In this example, the person 112 is holding the object 124 out in front of his body at about arm's length. This distance is shown to be the approximate arm's length detect (ALD) that defines the location of the approximate place where the image capture device 105 will attempt to capture the position of the hand 122 and associated object 124. The approximate arm's length detect (ALD) can vary, depending upon the user's arm length, but generally
10 should be provided to allow a distance relationship between the location of the head 120 and the hand 122. For instance, there should be at least a minor projection of the hand 122 in front of the person's body to point to different locations of the display screen 110.

[0032] Figure 3 illustrates a front view of the person 112 where the head 120 is identified and the hand 122 is identified, from the captured digital image. In this example, a dashed
15 line represents the display screen 110 and the image capture device 105 that is directionally pointed at the person 112. In this example, the image capture device 105 will be illustrated to be at a coordinate space of $(0, 0, 0)$, representing the reference point of the image capture device 105, and its position in coordinate space. The approximate location of the head 120 will also have an associated coordinate space (x_H, y_H, z_H) . Likewise, the hand 122 and
20 the associated object 124 that is held by the hand 122 will have a coordinate space (x_h, y_h, z_h) that is relative to the image capture device 105.

[0033] Figure 4 illustrates the person 112 pointing the object 124 at the display screen 110. In this example, the coordinate space of the head 120 is identified in the digital image

captured by the capture device 105. The location in coordinate space of the hand 122 is also captured in the digital image captured by the image capture device 105 when the person 112 is pointing at the display screen 110. The image capture device 105 is the reference point, which is at the coordinate space (0, 0, 0). The altitude angle phi is therefore calculated
5 between the position of the head 120 relative to the position of the hand 122. In one example, the angle is calculated as:

$$\text{Altitude angle} = \arctan ((y_h - y_H) / (z_h - z_H))$$

[0034] In a similar manner, the azimuth angle theta of Figure 2 is calculated as:

$$\text{Azimuth angle} = \arctan ((x_h - x_H) / (z_h - z_H))$$

10 [0035] When the user moves his hand down (e.g., as captured in a later frame) as illustrated in Figure 4, a new angle ϕ_2 will be produced to define the new relative position between the hand 122 and the head 120 of the person 112. Based on this new relative positioning of the head and the hand, the computer 102 will re-position the pointing direction on the display screen.

15 [0036] Figure 5A illustrates an embodiment where the object 124 is a gun. The gun may be a simplified gun object that is configured to be pointed in the direction of the display screen 110 to hit particular objects or interact with objects on the display screen 110. In this example, the gun 124 will include a detection region 124a. Detection region 124a is the region which is directionally pointed toward the display screen 110. The detection region
20 124a is also the region that is captured by the image capture device 105 for analysis of the digital image by the computer 102. In one embodiment, the detection region 124a is configured to include a pair of lighting objects that will assist in the interactivity with the

computer program being executed by the computer 102 and displayed on the display screen 110. In this example, a tracking indicator 130 is provided as a light or color object that is present on the detection region 124a. Based on the tracking indicator 130, the image capture device 105 will produce a digital image that will be analyzed by the computer 102 to

5 identify the position in coordinate space of the object 124. In this example, by providing the tracking indicator 130, the computer program being executed on the computer 102 is able to quickly identify the location of the object 124 and in relation to the head 120 of the person interacting with the computer program.

[0037] The tracking indicator 130 may be provided by way of a number of

10 implementations. One implementation might be a light indicator that can be tracked by the computer program that analyzes the captured digital images, or may be in the form of a color indicator that the computer can identify quickly from the captured digital images. The hand itself may be the tracking indicator 130. In still another embodiment, the tracing indicator 130 may be provided as a reflective tape that will have different coloring or

15 intensity depending on the angle that it might be displayed when shown to the image capture device 105. In this example, the object 104 is tracked as the user moves his hand 122 to different regions pointed to on the display screen 110.

[0038] In one embodiment, while the user moves his hand 122 relative to the head 120, the tracking indicator 130 will allow the computer program to provide a visual indicator on the

20 display screen 110. This visual indicator on the display screen 110 will allow the user to understand where the object is currently pointing to on the display screen 110.

[0039] In another embodiment, the detection region 124a will also include a trigger indicator 132. The trigger indicator 132 may be in the form of a light that is triggered ON

and OFF when the user pulls the trigger of the object 124. For instance, the detection region 124a is shown in Figure 5B after the trigger has been pulled and the trigger indicator 132 is lit. When the trigger indicator 132 is lit as shown in Figure 5B, the computer program executing on the computer 102 will provide an indicator on the display screen 110 so that the user can identify whether his or her pointing has accurately hit an object of the computer game. In Figure 5C, the trigger indicator 132 is shown to be in the OFF position to signify that the object 124 will still remain actively tracked, but the shooting which can be continuous or intermittent, can be discontinued when the user removes his finger from the trigger of the object 124. The trigger indicator 132 may be in any frequency range, including audio, ultrasonic, visible lightwave, infrared and radio. Passive trigger indication may be achieved with the trigger indicator 132. For example a mechanical sound may be generated upon actuating a trigger and the sound may be received and decoded at an audio input to the computer 102 to determine whether the trigger was actuated.

[0040] Figure 6A illustrates another embodiment of the present invention where tracking and trigger indicators 130a and 132a are provided. In this example, the track/trigger indicators 130a and 132a are provided so that determinations can be made of the relative distances between the two indicators as shown by distance (d_1). In one example, the object, when pointed at the image capture device 105 may respond by having the computer program that is executed on the computer 102 to ascertain the distance d_1 and perform an interactive action on the display screen. When the object 124b is tilted relative to the starting position of Figure 6A, a second distance (d_2) is computed. This distance is the new distance between the track/trigger indicators 130a and 132a. As the user continues to tilt the object 124b as shown in Figure 6C, the distance continues to shrink as shown by distance (d_3). Once the object 124b has been placed in the horizontal position relative to the vertical position of

Figure 6A, the distance between the track and trigger indicators 130a and 132a is brought to approximately zero. At this point, the program may read that the user intends for a trigger action to occur, or any other action that can be triggered when the detected distance from d_1 to d_4 has been detected.

5 [0041] In another embodiment, the response by the computer program may be gradually changed, depending on the angle at which the detection region 124b is tilted. For instance, the user may immediately begin to shoot the gun (or trigger the shooting of the gun) when the tilting begins and is executed between the tilt of Figure 6B to the tilt of Figure 6D. When the user tilts the gun back to the original position, the gun may discontinue the
10 shooting activity. Consequently, the trigger activity caused by analyzing the patterns or colors of the tracking and trigger indicators of 130a and 132b can cause the computer program to react in different interactive ways.

[0042] An example of this interactivity may be to trigger a reloading operation to occur for a gun that is being used in a video game, or a change of gun type being used on the video
15 game program. Once these changes are processed, the video display screen 110 will produce a different graphical animation for the user, depending upon the control being provided and detected by the image capture device.

[0043] Commands and trigger states are not limited to an ON and OFF parameters, but can be incrementally changed depending on the position of the relative state and angles of the
20 trigger and track indicators. For example, the state of the trigger may be determined in a linear or variable state as opposed to ON or OFF. Any known technique can be used to determine the relative trigger position including a resistive types used to control acceleration in remote control race tracks. The device, or gun in this example, can communicate the state

of its trigger by encoding and transmitting its value in any of a multitude of ways known in the art. A variety of commands and gestures may be formulated based on the state of the trigger and the position of the device., including those based on all known machine recognizable gestures, which are now hereunder embodied in the present invention with a
5 variable state indicator to establish an additional index of user control to the device under control.

[0044] Figures 6E and 6F provide yet another embodiment where different colors may be used to track tilt or relative tilt between positions of the detection regions 124c. In this example, the track and trigger indicators 130b and 132b are square or rectangular in
10 dimension and can be defined by colored tapes, bar codes, light indicators, LEDs, or the like. As a user flips or tilts the detection region 124c from the position of Figure 6E to Figure 6F, for example, the reaction by the computer game as displayed on the computer display screen will change.

[0045] Figure 7 illustrates another embodiment of the present invention in which a hand
15 122 is used to control the interactivity on the display screen. The user may place the hand 122 in front of the image capture device 105 and it is tracked relative to the head of the person 112. In this example, the user's hand is extended having of an index finger 140 pointing at the display screen 110. The user's thumb 142 may be pointing upright to indicate to the computer program executing on the computer 102 that the trigger device has
20 not been activated. When the user's thumb 142 is moved down toward the index finger 140 in the direction 122a, the computer program executing on a computer 102 may detect from the captured digital image that the user intends to shoot or trigger or interactively point to a specific region on the display screen 110. Thus, the user's hand being placed in a different position can trigger an event or cause the interactivity of a command with a computer

program being executed and shown on the display screen 110. For example, the user may be able to shoot by different hand gestures, may be able to reload the gun with different gestures, and the different positions or orientations of the user's hand may cause different graphical renderings of the user or gun on the display screen when the user is interacting

5 with a particular game program. In this embodiment, the state of the trigger may be determined ON or OFF as described above, or, the trigger may be determined in a variable state. In the latter, the relative position of the user's thumb may range from, for example, the position in which the thumb is substantially perpendicular to the pointing finger and the position where the thumb is substantially parallel to the pointing finger and where the

10 system performs image analysis of the hand to yield a relative state of the thumb. This state may be mapped to various control schemes, including those relating to a scroll-wheel on mouse.

[0046] Figures 8A and 8B illustrate another example where the user's hand 122 may be used to identify or trigger different activity on the display screen. In this example, Figure

15 8A shows the user pointing directly at the display screen 110 and the computer program being executed to identify this hand orientation on the digital image that was captured by the capture device. When a subsequent capture period occurs at a different point in time, the image of Figure 8B might be captured and analyzed by the computer program. In this example, the user's hand is shown tilted from where the thumb 142 is pointing upright to

20 where the thumb 142 is pointing sideways. In this orientation, the user may be able to trigger the shooting of a gun on the display screen, or the selection of an icon on a graphical display.

[0047] Consequently, the detection of the user's hand and the orientation of the user's hand can be used to provide the interactivity necessary when analyzing the position of the

user's hand relative to the user's head, and the pointing activity on a display screen. The pointing activity will allow the user to control the device under operation, select icons, shoot at graphical objects, select or scroll graphical objects, de-select graphical objects, turn ON and OFF graphical objects, disperse graphical objects, or simply interface with the graphics icons and features of a computer program being displayed on a display screen 110.

However, in certain configurations, it may be desirable, that the system employing the present invention may operate with minimal or no icons on a display screen. Instead, the system may simply just recognize the gestures of the user and provide a control input to the device under operation. For example, a television or related peripheral configured or integrated with the present invention may be controlled by the present invention. Changing a channel, for example, may not necessarily involve interacting with an icon as opposed to recognizing a gesture command according to the scheme presented in the present invention.

[0048] Figure 9 illustrates a flowchart diagram 200 where a process for identifying a pointing direction is described, in accordance with one embodiment of the present invention. In operation 202, the method begins by providing a capture device for capturing image frames. The frame capture rate will depend on the particular implementation, and will not limit the invention described herein. The capture device will, in one embodiment, include a capture location in coordinate space. As shown in Figure 4, the coordinate space of the image capture device is (0, 0, 0). In operation 204, a display screen is provided for rendering and displaying the interactive graphics of a computer program.

[0049] The interactive graphics of the computer program may be associate with a computer game, but may also be associated with any other program or interface that may require interactivity by a user. For instance, the interactivity may include the selection or de-selection of objects, opening files, changing channels, recording TV shows, closing files,

accessing files over a network, or interactively communicating with users by way of the internet, electronic mail or by electronic video mail, selecting a consumer electronic device, turning a device ON or OFF. Next, the operation 206 will include the capturing of an image that is presented in substantially in front of the image capture device. In one embodiment, 5 the image will include a person that is part of the captured space, and who is in front of the display screen and the capture device.

[0050] Once the image has been captured in operation 206, operation 208 will include the identification of a human head of the person that is found in the captured image. The identified human head will therefore be analyzed to ascertain the head location in the 10 coordinate space relative to the capture location. The method then moves to operation 210 where an object held by the person in the image is identified. The object's location is identified such that the coordinate space of the object is identified relative to the coordinate space of the capture location. Having the identified head location and the identified object location in memory, at operation 212 the computer program can identify a relative position 15 in coordinate space between the head location and the object location when viewed from the capture location reference point (e.g., coordinate (0,0,0)). As mentioned above, an azimuth angle and an altitude angle can be computed for the relative locations of the head and the hand relative to the image capture device. This relative position in coordinate space is calculated for the captured frame. As will be discussed below, the relative position in 20 coordinate space may include a dimension of depth relative to the capture location reference point. Such dimension of depth may be determined using stereoscopic imaging or sound location techniques as discussed in detail below or a combination of such techniques.

[0051] In operation 214, a pointing direction is established for the object using the relative position identified between the object location and the head location. The pointing direction

is displayed on the display screen to enable interaction with the interactive graphics provided by the computer program and displayed on the display screen.

[0052] Figure 10 illustrates a more detailed process diagram 250 that can be implemented when determining the pointing direction of an object that is directionally pointed at a display
5 screen during an interactivity with a computer program. The method begins at operation 252 where the capture device for capturing image frames is provided. The capture device will have a capture location in coordinate space. The coordinate space of the capture location will be the reference point for performing operations to determine relative locations in the process of identifying directionality pointing.

10 [0053] The method moves to operation 254 where a display screen is provided for rendering interactive graphics of the computer program. The interactive graphics may be a computer game or may be any other program as defined above. In operation 256, an image is captured in front of the image capture device and a person is captured in the image. The captured image may be that of a digital frame of video. In one embodiment, the digital
15 frame of video may be a JPEG frame or may be part of a compressed video frame (e.g., MPEG or the like).

[0054] Next, the operation moves to the identification of a human head of the person in the captured image in operation 258. The human head is analyzed on the captured image to determine a head location and the coordinate space relative to the image capture device. In
20 operation 260, the method moves to the identification of an object held by the person in the image and determining an object location in the coordinate space. In operation 262, a relative position is identified in the coordinate space between the head location and the object location when viewed from the capture location of the capture device. The relative

position will include a calculation of an azimuth angle and an altitude angle relative to the image capture device. As will be discussed below, the object location in coordinate space may include a dimension of depth relative to the capture location reference point. Such dimension of depth may be determined using stereoscopic imaging or sound location

5 techniques as discussed in detail below or a combination of such techniques.

[0055] In operation 264, during execution of the computer program, the operations identified as A, B, C and D corresponding to operations 256, 258, 260, and 262 will be performed iteratively and continuously, depending on a rate desired for the performance of a computer program. For instance, the execution of operations A through D will occur at the

10 rate of one time for each frame that is captured or only after a certain number of frames are captured. The rate at which operations A through D are performed will therefore depend on the specific environment and the need for accurate detection of the pointer location and the select ability of interactive objects on the display screen. If the display screen is processing a video game that has objects that are moving at rapid rates, the tracking operation may

15 require that operations A through D be performed for each frame that is displayed on the video display screen.

[0056] In operation 266, the method indicates a continual update of the point and direction of the object using the relative position. The pointing direction is displayed on the display screen to enable interaction with the interactive graphics of the computer program. It should

20 again be understood that the pointing direction can be to enable a user to select icons, de-select icons, move icons, open objects, open files, save files, move files, and interact with files that may be part of a file database, or part of a graphical user interface on a computer desktop or the like.

[0057] Figure 11 is a block diagram of an exemplary user input system for interaction with an object on a graphical display that can be used to implement embodiments of the present invention. As shown in Figure 11, the user input system is comprised of a video capture device 300, an input image processor 302, an output image processor 304, and a video display device 306. Video capture device 300 may be any device capable of capturing sequences of video images, and, in one embodiment, is a digital video camera (such as a “web-cam”), or similar image capturing device. As mentioned above, the video capture device may be configured to provide depth image. Input image processor 302 translates the captured video images of the control object into signals that are delivered to an output image processor. In one embodiment, input image processor 302 is programmed to isolate the control object from the background in the captured video image through the depth information and generate an output signal responsive to the position and/or movement of the control object. The output image processor 304 is programmed to effect translational and/or rotational movement of an object on the video display device 306 in response to signals received from the input image processor 302.

[0058] These and additional aspects of the present invention may be implemented by one or more processors which execute software instructions. According to one embodiment of the present invention, a single processor executes both input image processing and output image processing. However, as shown in the figures and for ease of description, the processing operations are shown as being divided between an input image processor 302 and an output image processor 304. It should be noted that the invention is in no way to be interpreted as limited to any special processor configuration, such as more than one processor. The multiple processing blocks shown in Figure 11 are shown only for convenience of description.

[0059] Figure 12 is a simplified block diagram of a computer processing system configured to implement the embodiments of the invention described herein. The processing system may represent a computer-based entertainment system embodiment that includes central processing unit (“CPU”) 424 coupled to main memory 420 and graphical processing unit (“GPU”) 426. CPU 424 is also coupled to Input/Output Processor (“IOP”) Bus 428. In one embodiment, GPU 426 includes an internal buffer for fast processing of pixel based graphical data. Additionally, GPU 426 can include an output processing portion or functionality to convert the image data processed into standard television signals, for example NTSC or PAL, for transmission to display device 427 connected external to the entertainment system or elements thereof. Alternatively, data output signals can be provided to a display device other than a television monitor, such as a computer monitor, LCD (Liquid Crystal Display) device, or other type of display device.

[0060] IOP bus 428 couples CPU 424 to various input/output devices and other busses or device. IOP bus 428 is connected to input/output processor memory 430, controller 432, memory card 434, Universal Serial Bus (USB) port 436, IEEE1394 (also known as a Firewire interface) port 438, and bus 450. Bus 450 couples several other system components to CPU 424, including operating system (“OS”) ROM 440, flash memory 442, sound processing unit (“SPU”) 444, optical disc controlling 4, and hard disk drive (“HDD”) 448. In one aspect of this embodiment, the video capture device can be directly connected to IOP bus 428 for transmission therethrough to CPU 424; where, data from the video capture device can be used to change or update the values used to generate the graphics images in GPU 426. Moreover, embodiments of the present invention can use a variety of image processing configurations and techniques, such as those described in U.S. Patent Application Serial No. 10/365,120 filed February 11, 2003, and entitled METHOD AND

APPARATUS FOR REAL TIME MOTION CAPTURE, which is hereby incorporated by reference in its entirety. The computer processing system may run on a CELL™ processor.

[0061] Programs or computer instructions embodying aspects of the present invention can be provided by several different methods. For example, the user input method for
5 interaction with graphical images can be provided in the form of a program stored in HDD 448, flash memory 442, OS ROM 240, or on memory card 432. Alternatively, the program can be downloaded to the processing unit through one or more input ports coupled to CPU 424. The program modules defining the input method can be provided with the game or application program that is executed by CPU 424 and displayed on display device 427 or
10 they may be provided separately from the application program, such as for execution from local main memory 420.

[0062] In still another embodiment, the program may be executed partially on a server connected to the internet and partially on the local computer (e.g., game console, desktop, laptop, or wireless hand held device). Still further, the execution can be entirely on a remote
15 server or processing machine, which provides the execution results to the local display screen. In this case, the local display or system should have minimal processing capabilities to receive the data over the network (e.g., like the Internet) and render the graphical data on the screen. The user's input, by way of the capture device can be communicated back to the server and then the response represented on the screen.

20 [0063] Figures 13A-13C illustrate embodiments where depth data is taken into consideration in order to better identify the object used to perform the directional pointing. The object can be something the person is holding or can also be the person's hand. In this description, the terms "depth camera" and "three-dimensional camera" refer to any camera that is capable of obtaining distance or depth information as well as two-dimensional pixel

information. For example, a depth camera can utilize controlled infrared lighting to obtain distance information. Another exemplary depth camera can be a stereo camera pair, which triangulates distance information using two standard cameras. Similarly, the term “depth sensing device” refers to any type of device that is capable of obtaining distance information
5 as well as two-dimensional pixel information.

[0064] Recent advances in three-dimensional imagery have opened the door for increased possibilities in real-time interactive computer animation. In particular, new “depth cameras” provide the ability to capture and map the third-dimension in addition to normal two-dimensional video imagery. With the new depth data, embodiments of the present invention
10 allow the placement of computer-generated objects in various positions within a video scene in real-time, including behind other objects.

[0065] Moreover, embodiments of the present invention provide real-time interactive gaming experiences for users. For example, users can interact with various computer-generated objects in real-time. Furthermore, video scenes can be altered in real-time to
15 enhance the user’s game experience. For example, computer generated costumes can be inserted over the user’s clothing, and computer generated light sources can be utilized to project virtual shadows within a video scene. Hence, using the embodiments of the present invention and a depth camera, users can experience an interactive game environment within their own living room.

20 [0066] Figure 13A is a block diagram of an exemplary system 500 for providing a real-time three-dimensional interactive environment, in accordance with an embodiment of the present invention. As shown in Figure 13A, the system 500 includes a depth camera 502, an input image processor 504, an output image processor 506, and a video display device 508.

[0067] As mentioned above, the depth camera 502 provides the ability to capture and map the third-dimension in addition to normal two-dimensional video imagery. Figures 13B and 13C illustrated the images generated by a typical depth camera 502. In particular, Figure 13B is an illustration showing two-dimensional data 520 captured using a typical depth camera. Similar to normal cameras, a depth camera captures two-dimensional data for a plurality of pixels that comprise the video image. These values are color values for the pixels, generally red, green, and blue (RGB) values for each pixel. In this manner, objects captured by the camera appear as two-dimension objects on a monitor. For example, in Figure 13B, the exemplary scene includes a cylinder object 522 and a sphere object 524 disposed on a table 526, which may be situated among hills 528.

[0068] However, unlike a conventional camera, a depth camera also captures depth values for the scene. Figure 13C is an illustration showing depth data 550 captured using a typical depth camera. As illustrated in Figure 13B, the depth camera captures the x and y components of a scene using RGB values for each pixel in the scene. However, as shown in Figure 13C, the depth camera also captures the z-components of the scene, which represent the depth values for the scene. Since the depth values correspond to the z-axis, the depth values are often referred to as z-values.

[0069] In operation, a z-value is captured for each pixel of the scene. Each z-value represents a distance from the camera to a particular object in the scene corresponding to the related pixel. For example, in Figure 13C, z-values are illustrated for the cylinder object 552, the sphere object 554, and part of the table 556. In addition, a maximum detection range is defined beyond which depth values will not be detected. For example, in Figure 13C the maximum depth range 558 appears as vertical plane wherein all pixels are given the same depth value. As will be described in greater detail below, this maximum range plane

can be utilized by the embodiments of the present invention to provide user defined object tracking. Thus, using a depth camera, each object can be tracked in three dimensions. As a result, a computer system of the embodiments of the present invention can utilize the z-values, along with the two-dimensional pixel data, to create an enhanced three-dimensional interactive environment for the user. For more information on depth analysis, reference may be made to US Patent Application No. 10/448,614, entitled System and Method for Providing a Real-time three dimensional interactive environment, having a filing date of May 29, 2003, which is incorporated herein by reference.

[0070] According to an embodiment of the invention, the depth camera 502 may also be a stereo eye camera as depicted in FIGs. 14A-14C. For example, an interactive game setup 1400 may include a first camera 1405A and a second camera 1405B separated from each other by a known distance D. The cameras may be mounted to the top of the display screen 110 and operably connected to the computer 102, e.g., by cables or wireless media. Each camera 105A, 105B has a field of view, the boundaries of which are indicated by the dashed lines in FIG. 14A. The optical axes of the two cameras may be oriented parallel to each other. Since the field of view for each camera is slightly different, they will produce slightly different images of the object 124 and/or the head 120. These differing views may be used to determine the depth z of objects relative to a plane containing the two cameras 1405A, 1405B.

[0071] The addition of an ability to measure depth allows the interactive game setup 100 to determine relative distances, e.g., between the head 120 and object 124. Such capability is also useful, e.g., in situations where the relative positions of the head 120 and object 124 are significant to the game. For example, where the object 124 is a gun, the angle of the gun

may be determined from the motion of the head 120 and the gun. Alternatively, moving the gun back toward the head 120 may act as a trigger to the game program to reload the gun.

[0072] By way of example, as shown in FIG. 14B, when the first camera 1405A produces an image of the head 120 and object 124, the object 124 may appear at a distance d_1 from an edge of the field of view of the first camera 1405A. Similarly, when the second camera 1405B produces an image of the head 120 and object 124, the object 124 may appear at a distance d_2 from an edge of the field of view of the second camera 1405B. The two distances d_1 , d_2 may be used to determine a depth z , e.g., using triangulation.

[0073] By way of example, and without limitation of the invention, the first and second cameras 1405A, 1405B may be as simple as a standard web cam or can include more advanced technology. In one embodiment, the cameras 1405A, 1405B are capable of capturing images, digitizing the images, and communicating the image data back to the computer 102. Each camera 1405A, 1405B may be capable of capturing images at a frame rate of about 120 frames per second. Each camera may have a field of view of about 75 degrees, and an f-stop of about 1.5.

[0074] By way of example and without limitation, the 1405A, 1405B may be color digital cameras that use computer vision to process images taken by the camera. Such cameras allow players to interact with games using motion, color detection and also, through built-in microphone, sound. In a particular embodiment, the cameras 1405A, 1405B are a pair of EyeToy Cameras available for Logitech of Fremont, California. The cameras 1405A, 1405B may have logic integrated therein for performing the digitizing. Alternatively, the cameras 1405A, 1405B may simply transmit the captured data back to the computer 102 for digitizing. In either case, the cameras 1405A, 1405B may be capable of capturing either color or black and white images of any object located in front of them.

[0075] It is often desirable to synchronize the timing of images from the two cameras 1405A, 1405B. There are a number of different schemes for doing so. For example, the cameras may be run using a common oscillator to synchronize their respective electronics. Alternatively, a strobe tower, 1402 may be used to synchronize two cameras having
5 independent oscillators. The strobe tower 1402 is placed in the field of view of both cameras 1405A, 1405B. The strobe tower includes an array of strobe signal generators, e.g., light emitting diodes (LEDs) 1404 that flash in a known sequence. For example each LED beginning with the LED on the left may flash a short period of time Δt after the previous LED has flashed. By way of example, the Δt may be set equal to twice the time step
10 between video image frames for the system 1400. Since each camera 1405A, 1405B can “see” the strobe tower 1402, images may be synchronized between the two cameras based on which LED 1404 is lit in the image.

[0076] In other embodiments, the strobe tower 1402 may include one or more LEDs that emit a light signal having a frequency that varies with respect to time. In such a case,
15 synchronization of images may be obtained from the frequency (or color) of the signal from the strobe tower 1402.

[0077] Use of a strobe tower 1402 also allows interpolation between images taken at different known times. For example, given two different positions of the object 124 determined at two different known times, it is possible to determine a velocity of the object
20 124 from the change in position and the time between images.

[0078] Certain embodiments of the invention may use sound to determine the positions of objects. For example, FIGs. 15A-15B depict an image capture device 1500 that may be used with an interactive game setup of the type described above. The device 1500 includes an optical image capture device 1505, e.g., a digital camera of any of the types described

above and an array of microphones 1502 that are spaced apart from each other at known distances. For example, the microphones 1502 may be spaced in a linear array with adjacent microphones spaced about 2 centimeters apart center-to-center. Each microphone may have a resonant frequency of about 48 kilohertz.

5 [0079] In certain embodiments of the invention it is desirable for the microphones 1502 to move with the image capture device 1505. For example, the microphones 1502 may be mounted to a frame 1504 that keeps the microphones in a fixed positional relationship with respect to the image capture device, e.g., with respect to a lens 1506. Although the microphones are depicted as being arrayed in a horizontal linear arrangement, they may
10 alternatively be oriented vertically or diagonally or arrayed in a two-dimensional arrangement.

[0080] The microphones 1502 may be coupled to the computer 102 or the device 1500 may include logic for interpreting audio signals received by the microphones 1502. The object 124 used in the video game (e.g., a gun) may include a sound emitter 1503. When
15 the sound emitter 1503 produces a sound the resulting sound waves arrive at the microphones at different times depending on the location of the object 124. The different arrival times may be used to determine a position of the object. The sound emitter may also serve as an audio trigger signal to the computer 102.

[0081] Each image capture device may be a digital camera as described above. Such a
20 camera may have a field of view of about 75 degrees, and an f-stop of about 1.5 and be capable of capturing images at a frame rate of up to about 120 frames per second.

[0082] In some embodiments, the device 1500 may include a visible LED 1508 and an infrared LED 1510. These may be used to illuminate objects in a field of view of the image capture device 1505. To facilitate capture of infrared images, the lens 1506 may include a

so-called “day-night” coating that transmits visible light and selected frequencies of the infrared (e.g., frequencies at around 940 nm).

[0083] In certain embodiments, two image capture devices 1500A, 1500B of the type shown in FIGs. 15A-15B may be used in stereo as shown in FIG. 15C in an interactive game
5 setup 1550, which may include a strobe tower 1402 as described above. Although two image capture devices 1500A, 1500B are depicted, a single device may alternatively be used and depth information may be determined using the microphones 1502 in conjunction with visual information from the single device.

[0084] Embodiments of the present invention also contemplate distributed image
10 processing configurations. For example, the invention is not limited to the captured image and display image processing taking place in one or even two locations, such as in the CPU or in the CPU and one other element. For example, the input image processing can just as readily take place in an associated CPU, processor or device that can perform processing; essentially all of image processing can be distributed throughout the interconnected system.
15 Thus, the present invention is not limited to any specific image processing hardware circuitry and/or software. The embodiments described herein are also not limited to any specific combination of general hardware circuitry and/or software, nor to any particular source for the instructions executed by processing components.

[0085] With the above embodiments in mind, it should be understood that the invention
20 may employ various computer-implemented operations involving data stored in computer systems. These operations include operations requiring physical manipulation of physical quantities. Usually, though not necessarily, these quantities take the form of electrical or magnetic signals capable of being stored, transferred, combined, compared, and otherwise

manipulated. Further, the manipulations performed are often referred to in terms, such as producing, identifying, determining, or comparing.

[0086] The above described invention may be practiced with other computer system configurations including hand-held devices, microprocessor systems, microprocessor-based
5 or programmable consumer electronics, minicomputers, mainframe computers and the like. The invention may also be practiced in distributing computing environments where tasks are performed by remote processing devices that are linked through a communications network.

[0087] The invention can also be embodied as computer readable code on a computer readable medium. The computer readable medium is any data storage device that can store
10 data which can be thereafter read by a computer system, including an electromagnetic wave carrier. Examples of the computer readable medium include hard drives, network attached storage (NAS), read-only memory, random-access memory, CD-ROMs, CD-Rs, CD-RWs, magnetic tapes, and other optical and non-optical data storage devices. The computer readable medium can also be distributed over a network coupled computer system so that
15 the computer readable code is stored and executed in a distributed fashion.

[0088] Although the foregoing invention has been described in some detail for purposes of clarity of understanding, it will be apparent that certain changes and modifications may be practiced within the scope of the appended claims. Accordingly, the present embodiments are to be considered as illustrative and not restrictive, and the invention is not to be limited
20 to the details given herein, but may be modified within the scope and equivalents of the appended claims.

What is claimed is:

CLAIMS

1. A method for detecting depth and direction when interfacing with a computer program, comprising:

- 5 (a) capturing stereo images presented in front of one or more image capture devices, wherein each image capture device has a capture location in a coordinate space; when a person is captured in the image,
- (b) identifying a human head in the image and assigning the human head a head location in the coordinate space;
- 10 (c) identifying an object held by the person in the image and assigning the object an object location in coordinate space; and
- (d) identifying a relative position in coordinate space between the head location and the object location when viewed from the capture location, wherein the relative position includes a dimension of depth with respect to the coordinate
- 15 space.

2. The method of claim 1 wherein the relative position defines a pointing direction of the object when viewed by the image capture device.

20 3 The method of claim 1, wherein the relative position is identified by computing an azimuth angle and an altitude angle between the head location and the object location in relation to the capture location.

4. The method of claim 1 wherein the dimension of depth is determined by taking first and second images with first and second image capture devices located at spaced-apart positions and measuring distances of an object in each image relative to a reference in each image.

5

5. A method for detecting direction when interfacing with a computer program as recited in claim 1, wherein the capture location is at a proximate location of a display screen and the display screen is capable of rendering interactive graphics.

10

6. The method of claim 5, wherein the pointing direction is toward the display screen.

15

7. The method of claim 5, further comprising:
repeating (a) - (d) continually to update the pointing direction; and
displaying the continually updated pointing direction on the display screen.

20

8. The method of claim 7, further comprising:
enabling selection of particular interactive graphics using the displayed
pointing direction.

9. The method of claim 8, wherein the selection is in response to a detected trigger event.

10. The method of claim 9, wherein the detected trigger event is identified in the image, the identification comprising,

identifying a first characteristic of the object held by the person at a first point in time; and

identifying a second characteristic of the object held by the person at a second point in time,

wherein the trigger event is activated when a degree of difference is determined to have existed between first characteristic and the second characteristic when examined between the first point in time and the second point in time.

11. The method of claim 10, wherein the trigger even being activated is indicative of interactivity with the interactive graphics.

12. The method of claim 11, wherein the interactivity can include one or more of selection of a graphic, shooting of a graphic, touching a graphic, moving of a graphic, activation of a graphic, triggering of a graphic and acting upon or with a graphic.

13. The method of claim 1, wherein identifying the human head is processed using template matching in combination with face detection code.

5 14. The method of claim 1, wherein identifying the object held by the person is facilitated by color tracking of a portion of the object.

15. The method of claim 14, wherein color tracking includes one or a combination of identifying differences in colors and identifying on/off states of colors.

10

16. The method of claim 6, wherein identifying the object held by the person is facilitated by identification of changes in positions of the object when repeating (a) - (d).

15 17. The method of claim 1, wherein the computer program is a video game.

18. The method of claim 1, further comprising synchronizing the image capture devices.

20

19. The method of claim 18 wherein synchronizing the image capture devices includes providing a strobe signal that is visible to each image capture device.

5 20. A method for detecting depth and direction when interfacing with a computer program, comprising:

(a) capturing an image presented in front of one or more image capture devices, wherein the image capture device has a capture location in a coordinate space;

when a person is captured in the image,

10 (b) identifying a human head in the image and assigning the human head a head location in the coordinate space;

(c) identifying an object held by the person in the image and assigning the object an object location in coordinate space;

15 (d) receiving at a plurality of microphones at known positions relative to the image capture device a sound signal originating from the object;

(e) identifying a relative position in coordinate space between the head location and the object location when viewed from the capture location, and the relative times of arrival of the sound signal at the microphones, wherein the relative position includes a dimension of depth with respect to the coordinate space.

20

21. A method for detecting pointing direction of an object directed toward a display screen that can render graphics of a computer program, comprising:

(a) capturing two or more stereo images presented in front of two or more image capture devices, each image capture device having a capture location in a coordinate space that is proximate to the display screen;

when a person is captured in the image,

5 (b) identifying a first body part of the person in the image and assigning the first body part a first location in the coordinate space;

(c) identifying a second body part of the person in the image and assigning the second body part a second location in coordinate space; and

10 (d) identifying a relative position in coordinate space between the first location and the second location when viewed from the capture location, wherein the relative position includes a dimension of depth.

22. The method of claim 21 wherein the relative position defines a pointing direction of the second body part when viewed by the image capture
15 device at the capture location that is proximate to the display screen.

23. The method of claim 21, wherein the first body part is a human head and the second body part is a human hand.

20 24. The method of 21, wherein (a) - (d) is repeated continually during execution of the computer program, and

examining a shape of the human hand during the repeating of (a) - (d) to determine particular shape changes.

5 25. The method of claim 21, wherein particular shape changes trigger interactivity with interactive graphics of the computer program.

10 26. The method of claim 25, wherein the interactivity can include one or more of selection of a graphic, shooting of a graphic, touching a graphic, moving of a graphic, activation of a graphic, triggering of a graphic and acting upon or with a graphic.

 27. The method of claim 21, wherein the second body part is identified by way of an object held by the human hand.

15 28. The method of claim 21, wherein the object includes color.

 29. The method of claim 28, wherein the color is capable of switching between states to trigger interactivity with interactive graphics of the computer program.

20

30. The method of claim 29, wherein additional colors are present on the object, the colors capable of being switched to trigger interactivity with interactive graphics of the computer program.

5 31. The method of claim 28, wherein the color can switch from on/off states to trigger interactivity with interactive graphics of the computer program

32. The method of claim 21, wherein the computer program is a video game.

10

33. The method of claim 21, wherein the relative position is identified by computing an azimuth angle and an altitude angle between the head location and the object location in relation to the capture location.

34. A method for detecting pointing direction of an object directed toward a display screen that can render graphics of a computer program, comprising:

(a) capturing an image presented in front an image capture device, the image capture device having a capture location in a coordinate space that is proximate to the display screen;

when a person is captured in the image,

20 (b) identifying a first body part of the person in the image and assigning the first body part a first location in the coordinate space;

(c) identifying a second body part of the person in the image and assigning the second body part a second location in coordinate space;

(d) receiving at a plurality of microphones at known positions relative to the image capture device a sound signal originating from the object; and

5 (e) identifying a relative position in coordinate space between the first location and the second location when viewed from the capture location, wherein the relative position includes a dimension of depth.

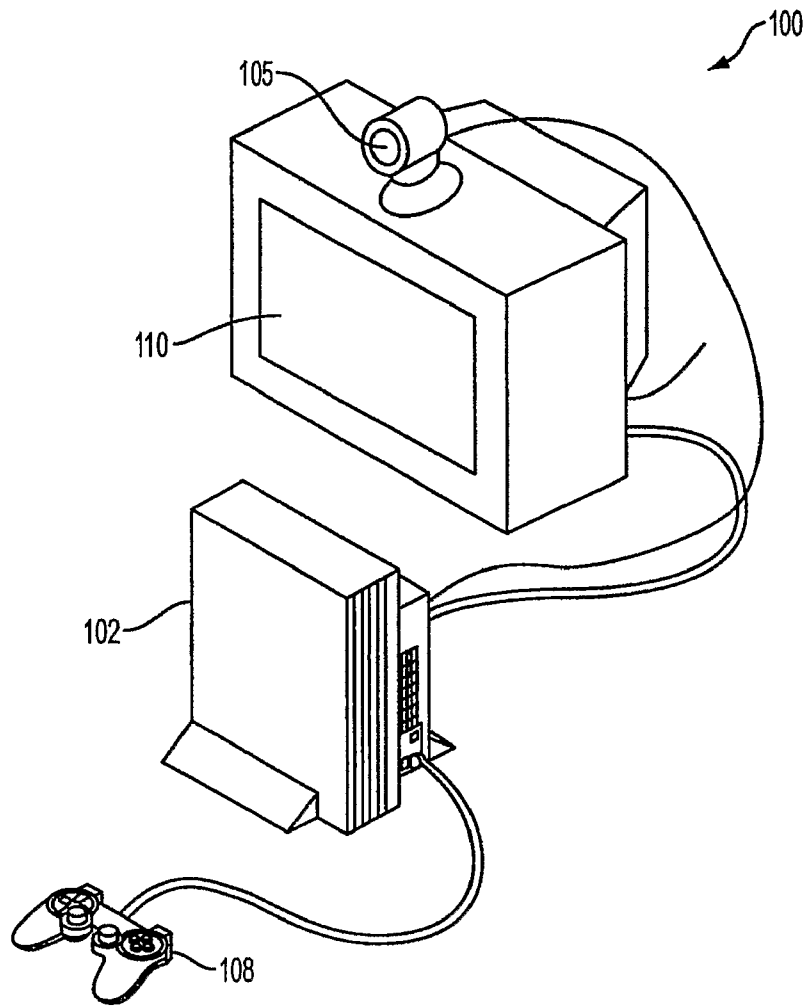

FIG. 1A

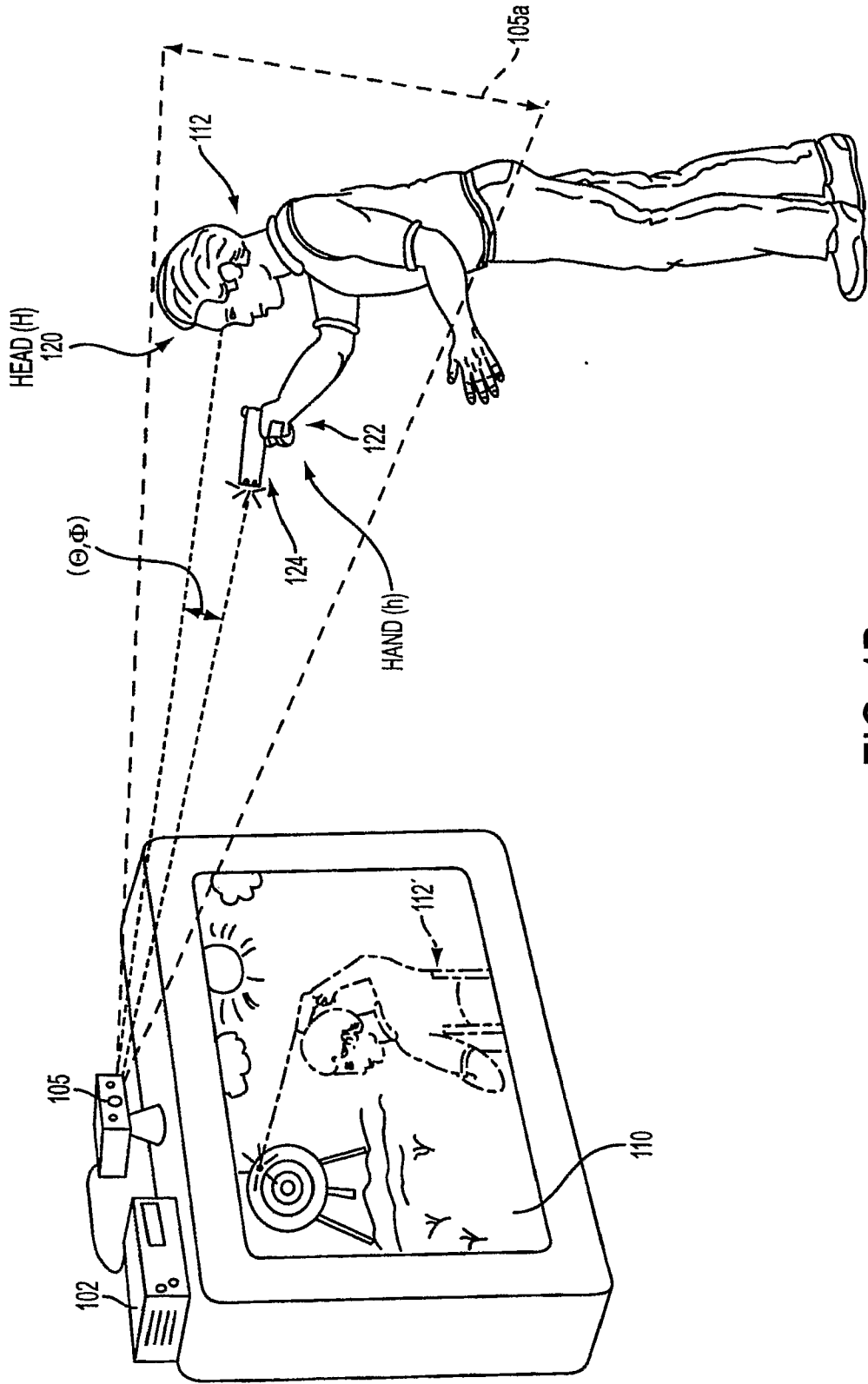

FIG. 1B

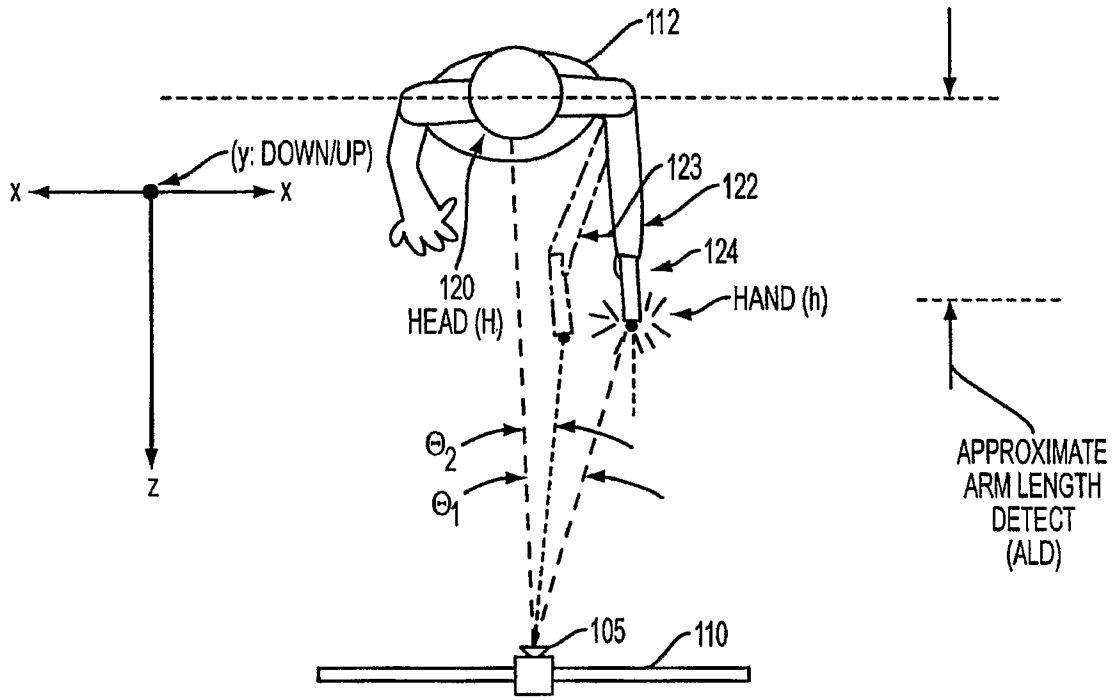

FIG. 2

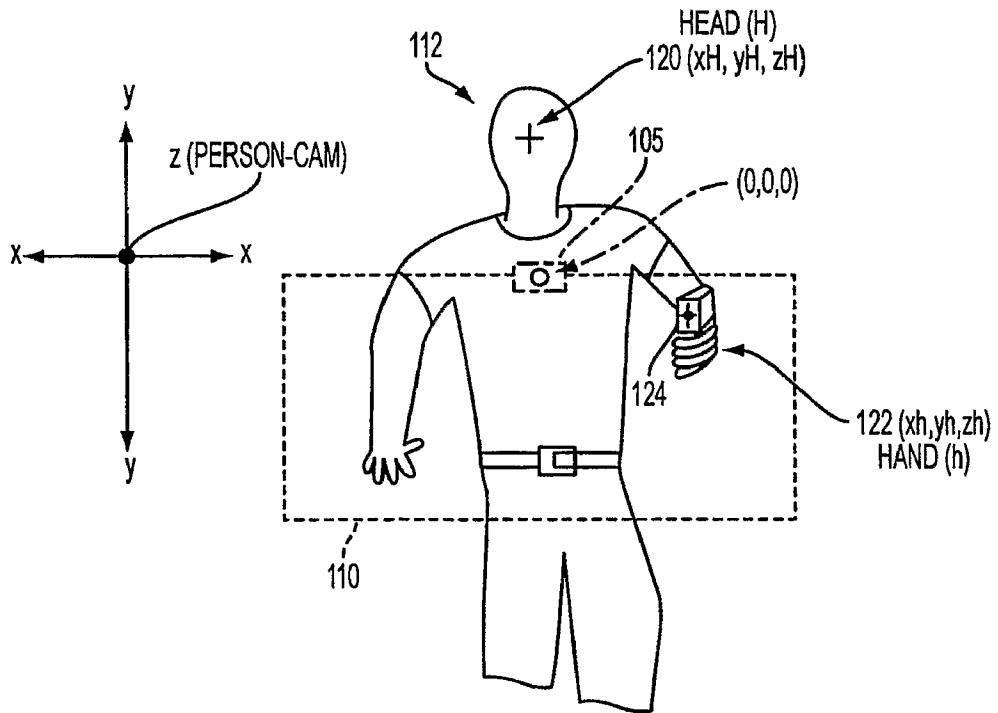

FIG. 3

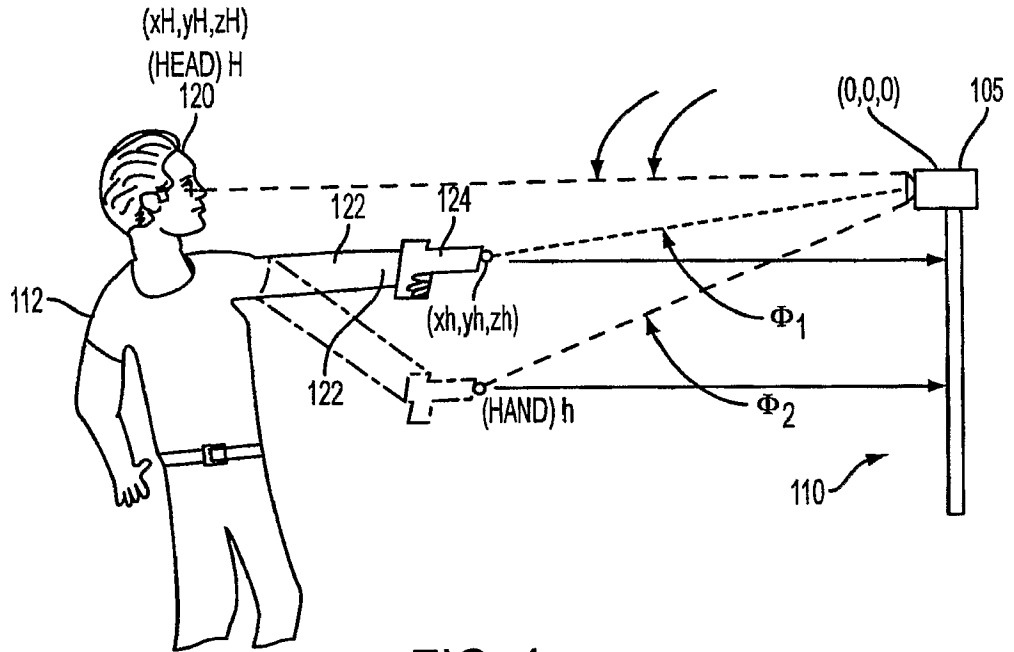

FIG. 4

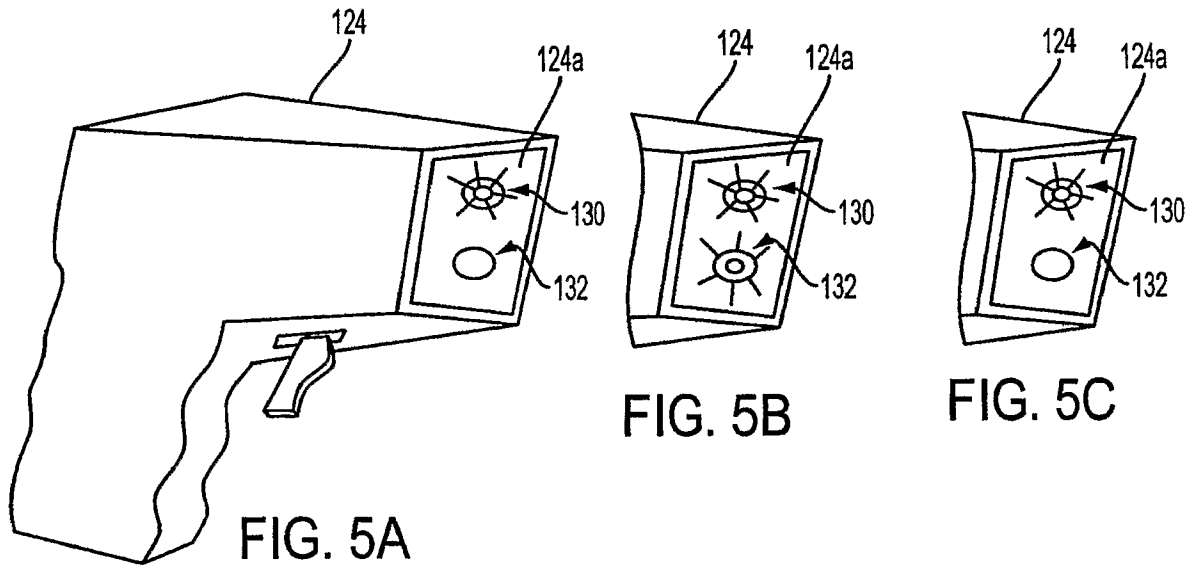
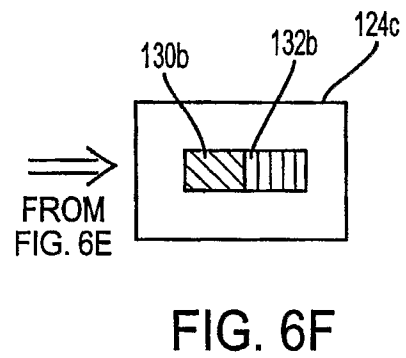
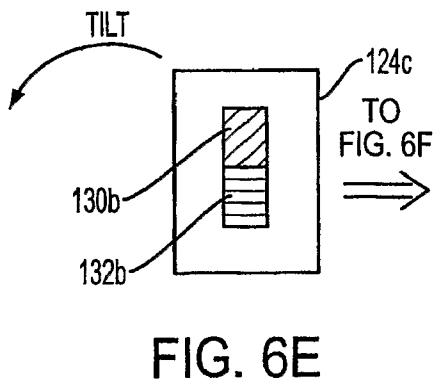
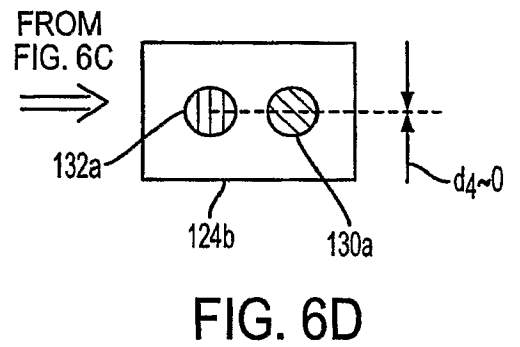
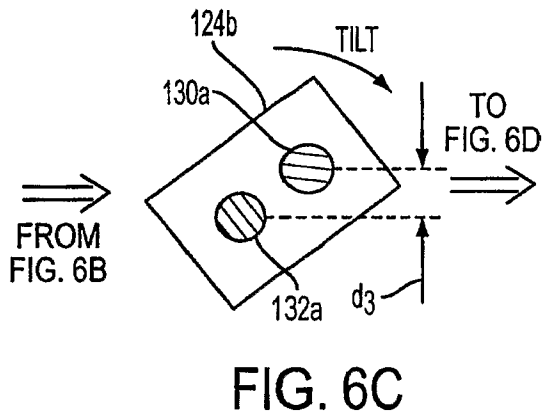
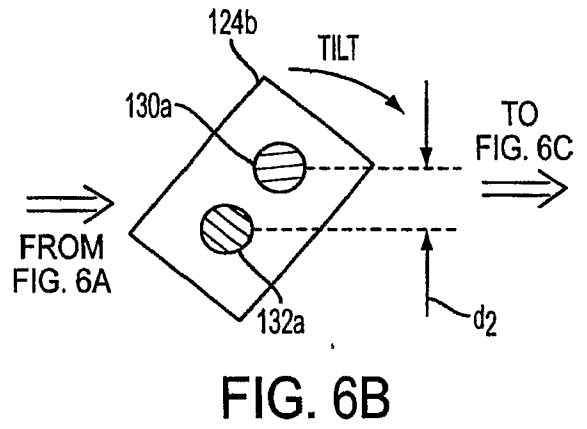
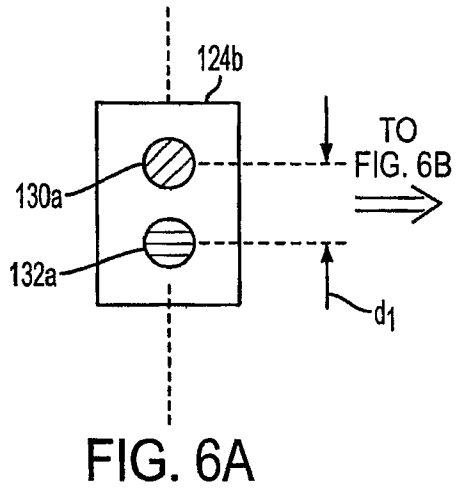
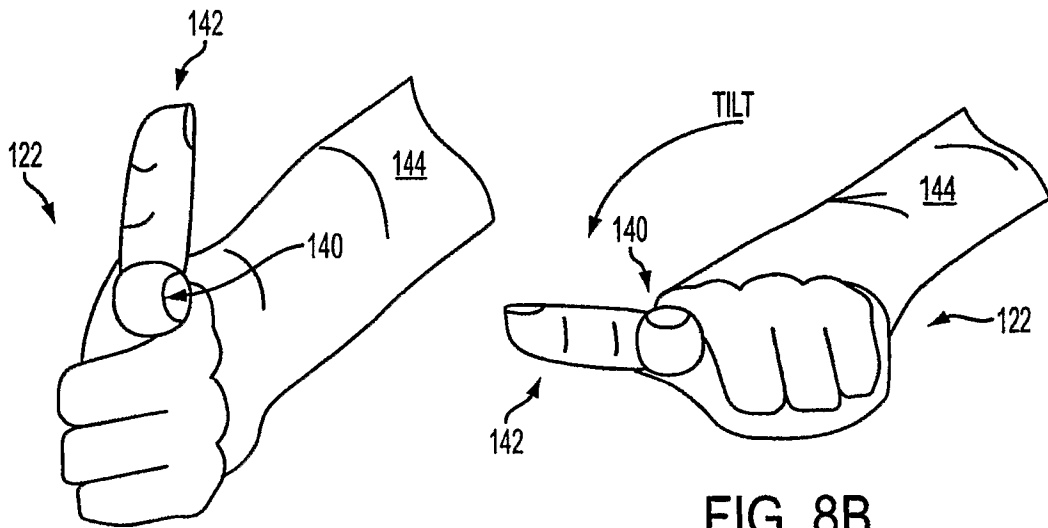
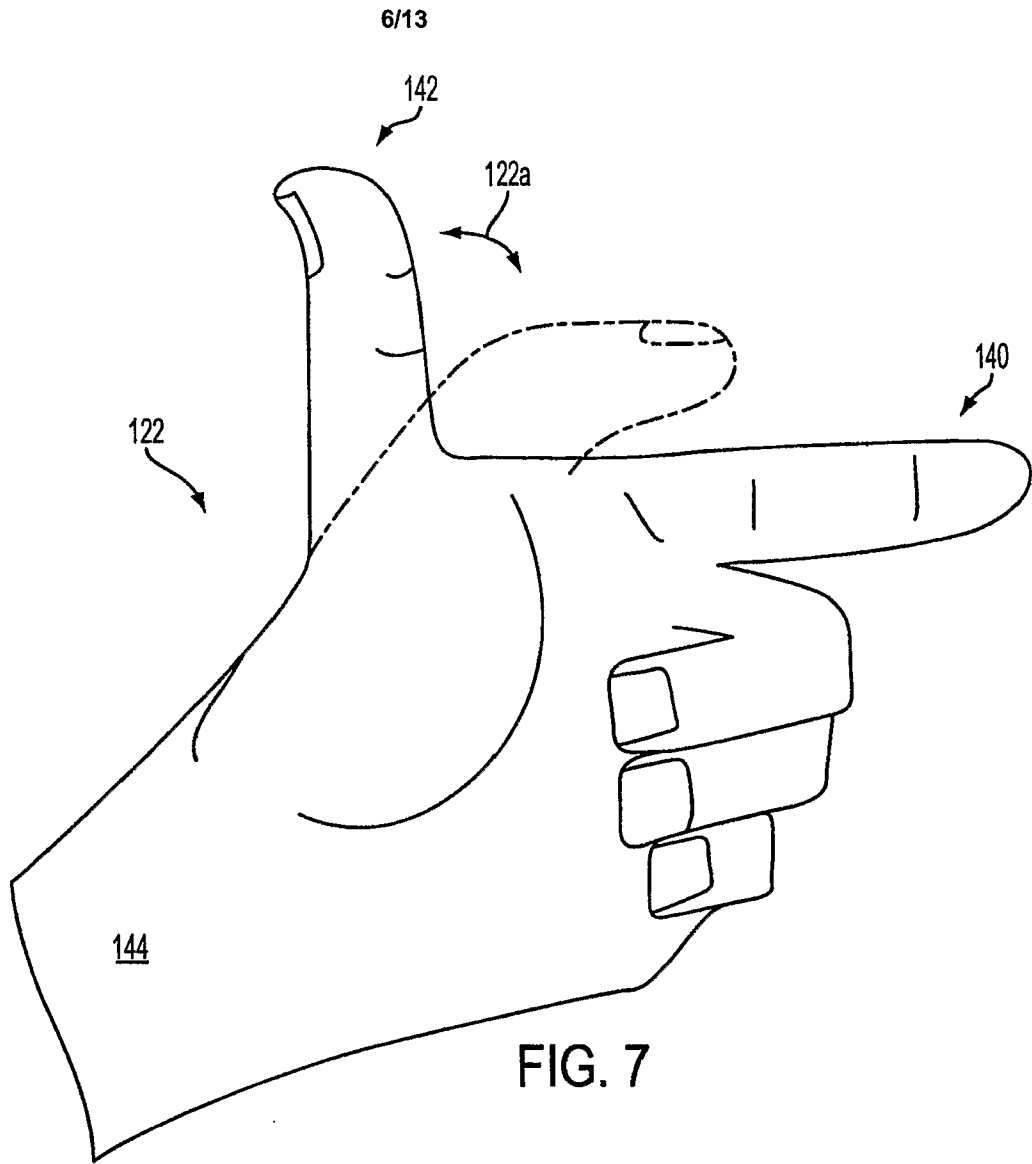

FIG. 5A

FIG. 5B

FIG. 5C





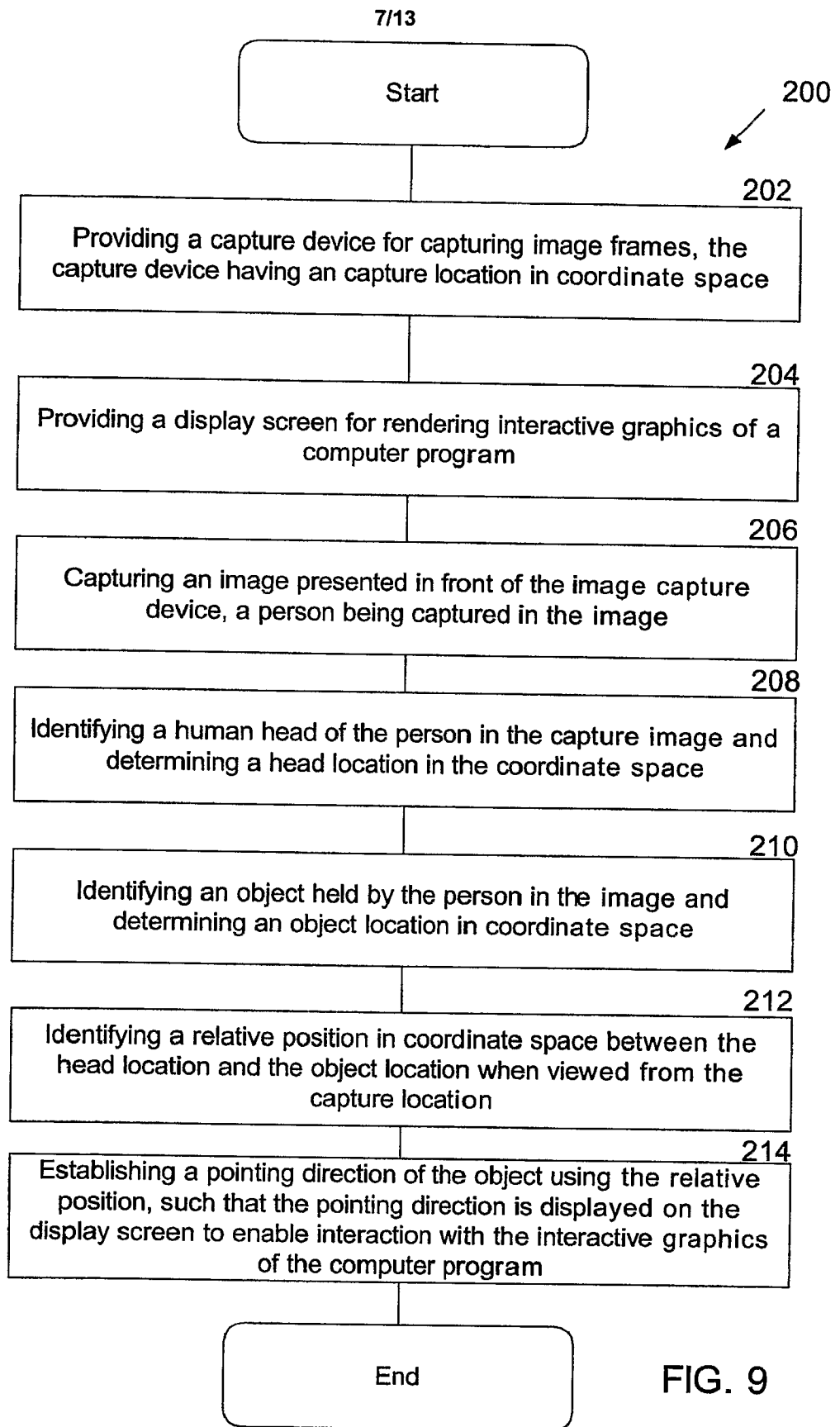

FIG. 9

8/13

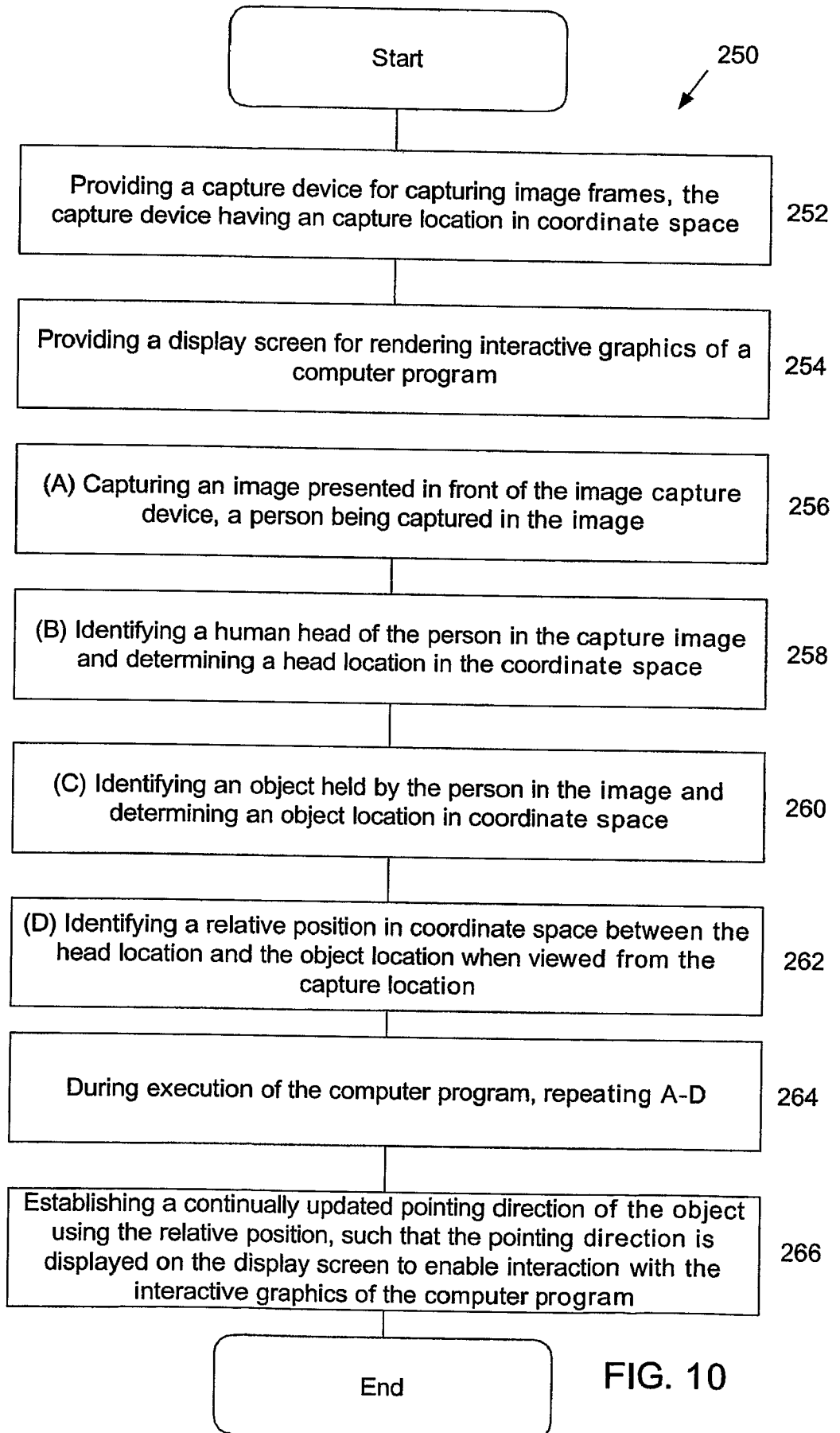

FIG. 10

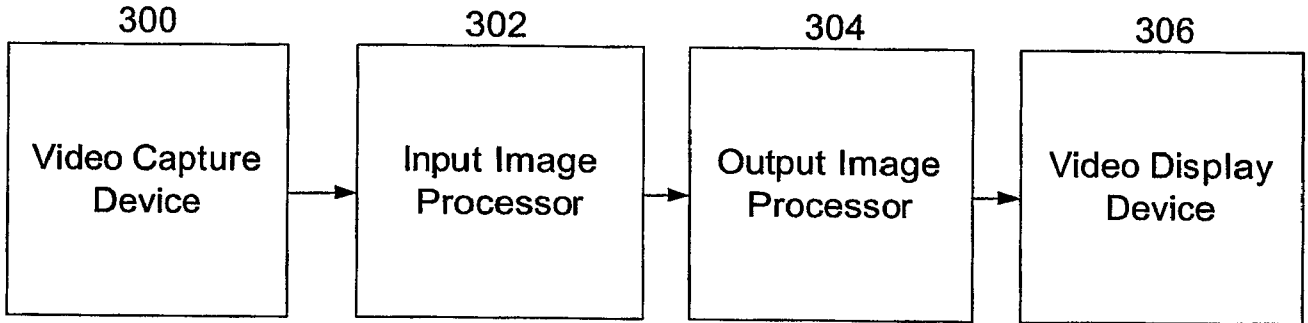

FIG. 11

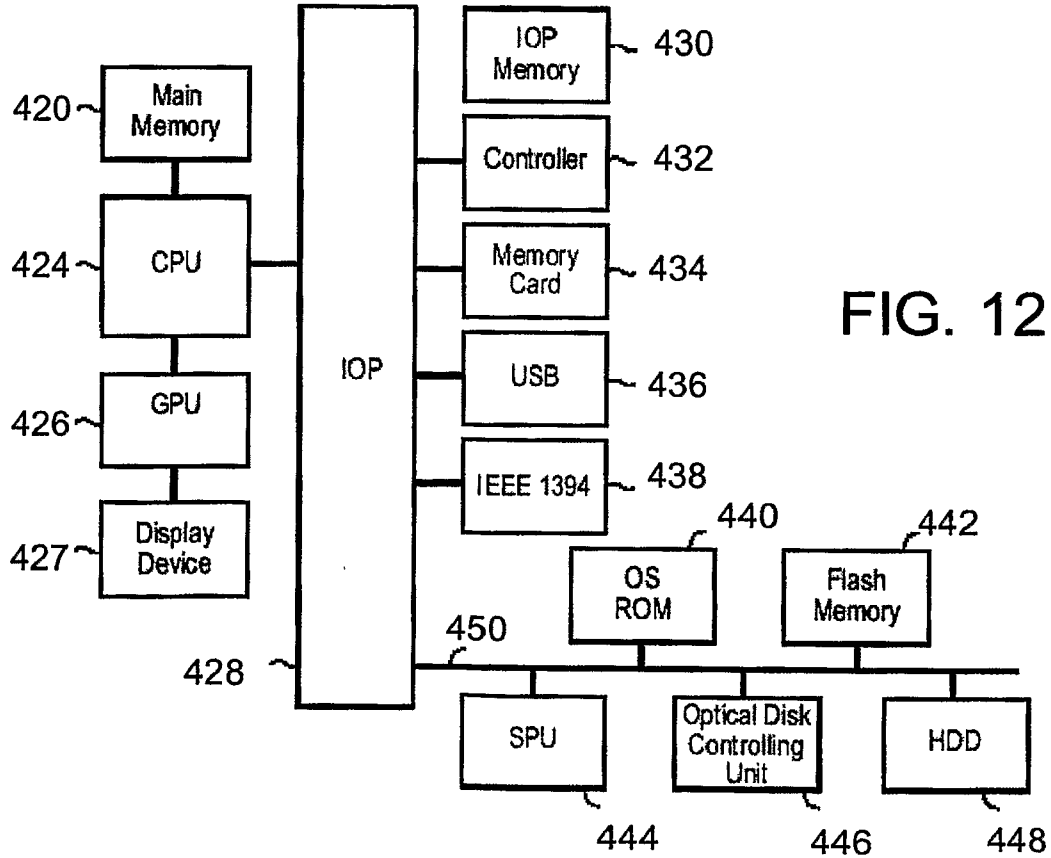

FIG. 12

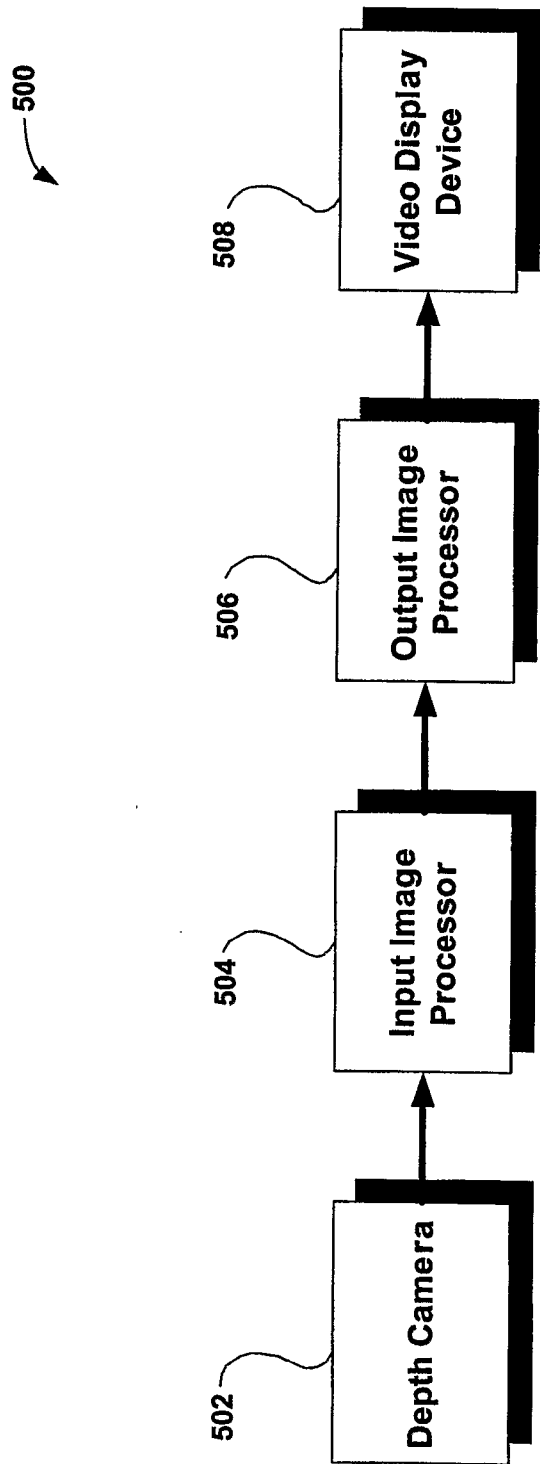
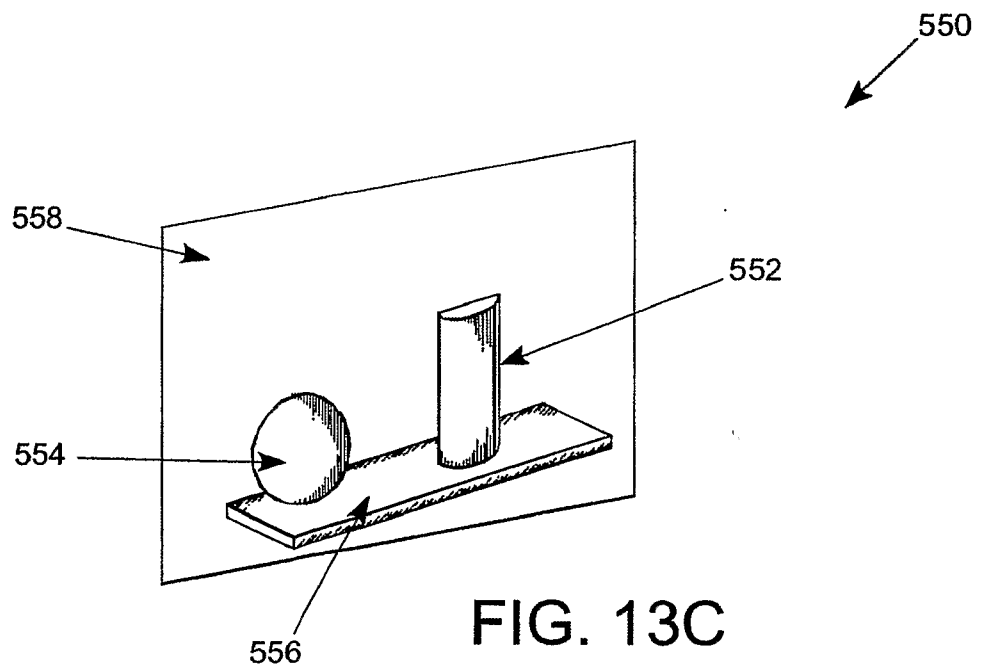
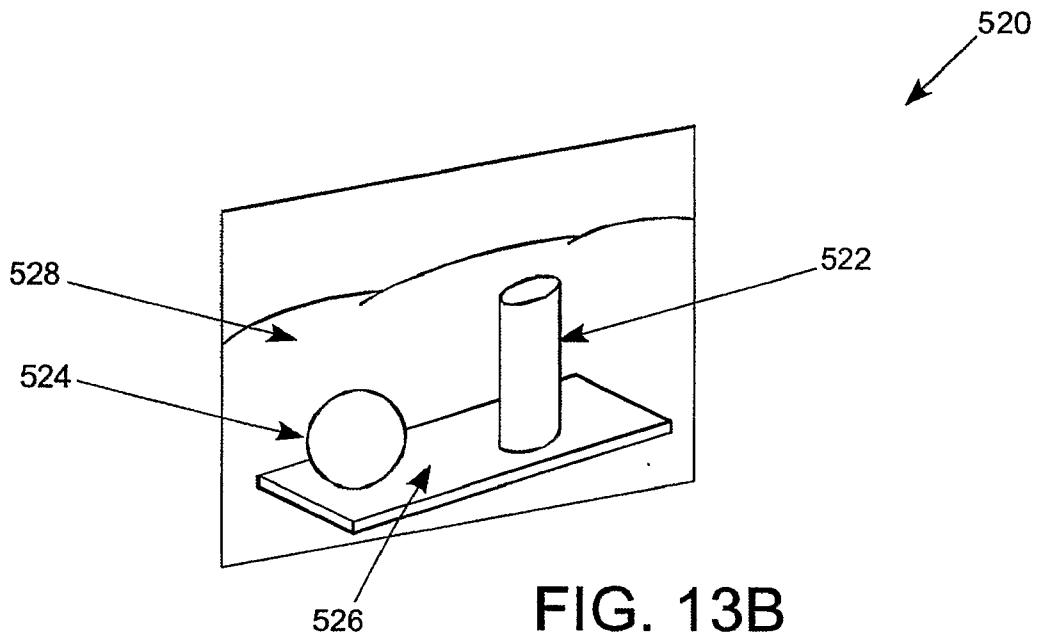

FIG. 13A



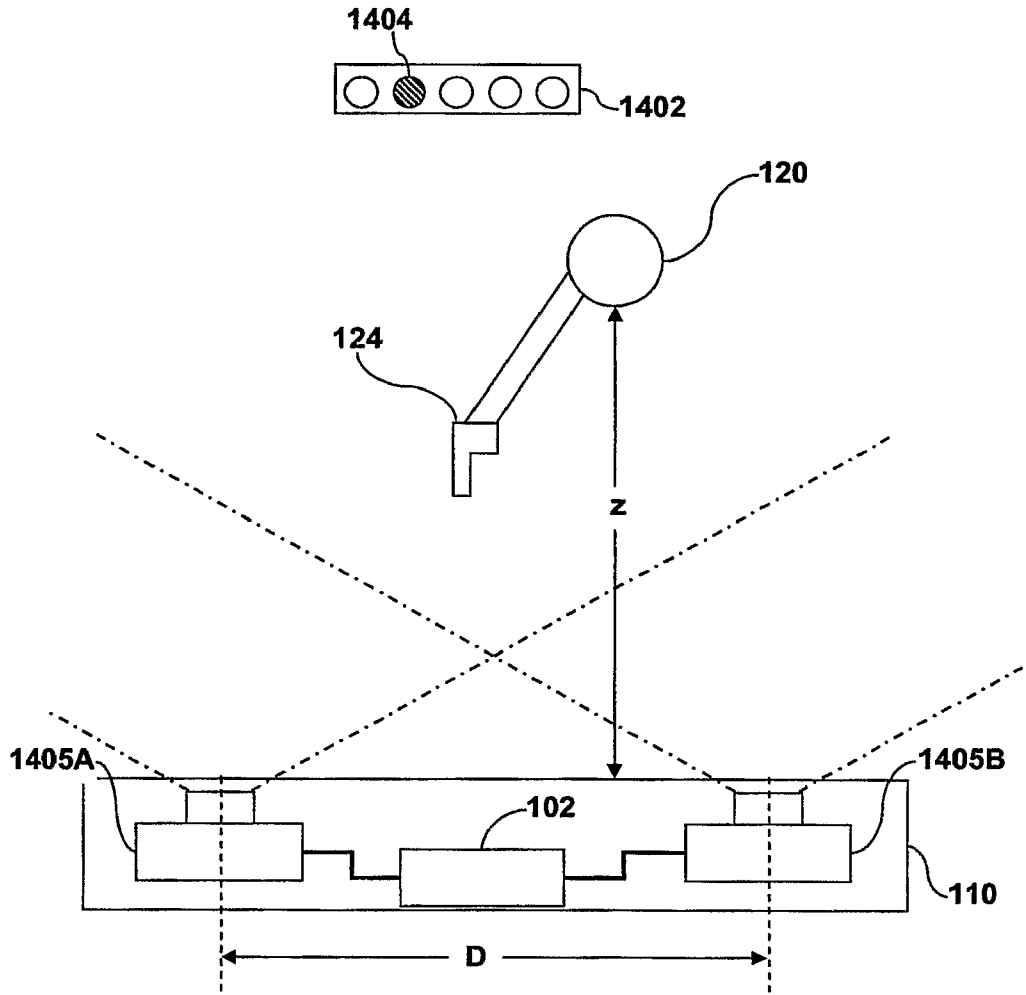

FIG. 14A

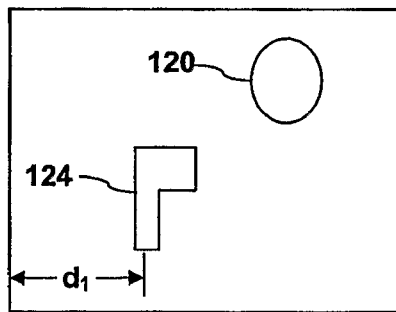

FIG. 14B

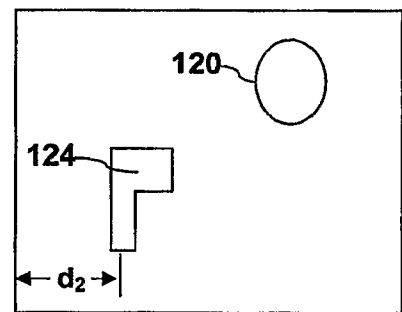

FIG. 14C

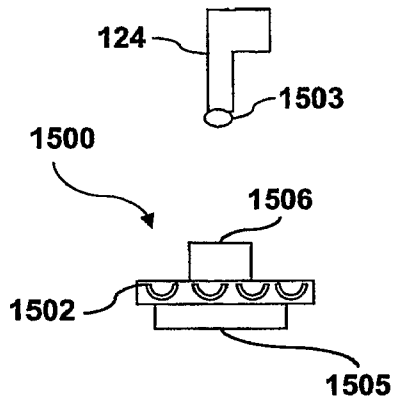

FIG. 15A

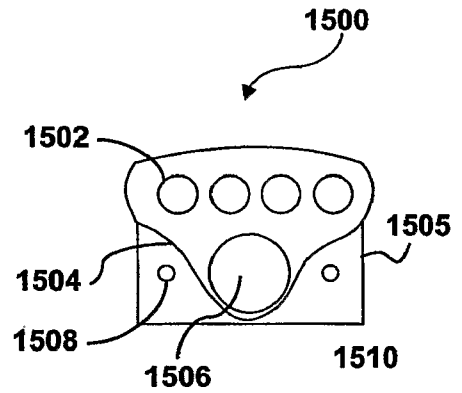

FIG. 15B

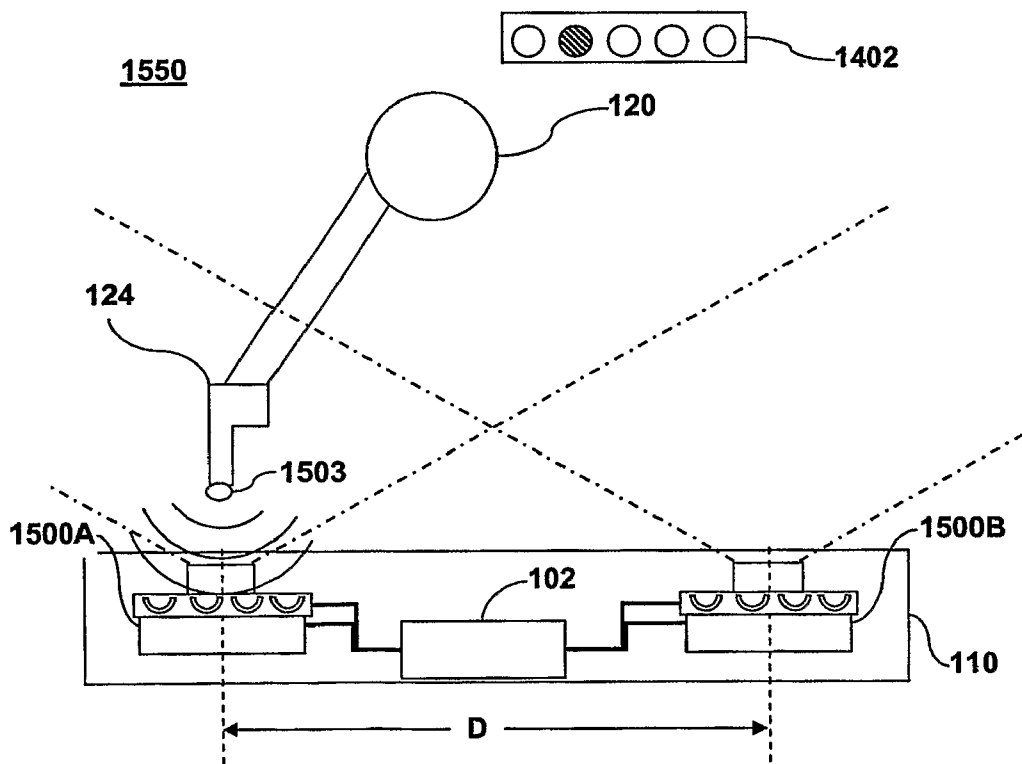

FIG. 15C