

(19) World Intellectual Property Organization  
International Bureau



(43) International Publication Date  
24 April 2003 (24.04.2003)

PCT

(10) International Publication Number  
**WO 03/032863 A2**

- (51) International Patent Classification<sup>7</sup>: **A61F**
- (21) International Application Number: PCT/US02/31569
- (22) International Filing Date: 15 October 2002 (15.10.2002)
- (25) Filing Language: English
- (26) Publication Language: English
- (30) Priority Data:
 

09/978,490	15 October 2001 (15.10.2001)	US
09/978,449	15 October 2001 (15.10.2001)	US
10/010,629	7 November 2001 (07.11.2001)	US
10/099,400	15 March 2002 (15.03.2002)	US
- (71) Applicant and
- (72) Inventor: **REED, Gary, J.** [US/US]; 1015 South Soderquist Road, Turlock, CA 95380 (US).
- (74) Agent: **KRETEN, Bernhard**; Bernhard Kreten, Esq. & Associates, 300 Capitol Mall, Suite 1100, Sacramento, CA 95814 (US).
- (81) Designated States (*national*): AE, AG, AL, AM, AT, AU, AZ, BA, BB, BG, BR, BY, BZ, CA, CH, CN, CO, CR, CU, CZ, DE, DK, DM, DZ, EC, EE, ES, FI, GB, GD, GE, GH, GM, HR, HU, ID, IL, IN, IS, JP, KE, KG, KP, KR, KZ, LC, LK, LR, LS, LT, LU, LV, MA, MD, MG, MK, MN, MW, MX, MZ, NO, NZ, OM, PH, PL, PT, RO, RU, SD, SE, SG, SI, SK, SL, TJ, TM, TN, TR, TT, TZ, UA, UG, UZ, VN, YU, ZA, ZM, ZW.
- (84) Designated States (*regional*): ARIPO patent (GH, GM, KE, LS, MW, MZ, SD, SL, SZ, TZ, UG, ZM, ZW), Eurasian patent (AM, AZ, BY, KG, KZ, MD, RU, TJ, TM), European patent (AT, BE, BG, CH, CY, CZ, DE, DK, EE, ES, FI, FR, GB, GR, IE, IT, LU, MC, NL, PT, SE, SK,

[Continued on next page]

(54) Title: ORTHOPEDIC STABILIZATION DEVICE AND METHOD

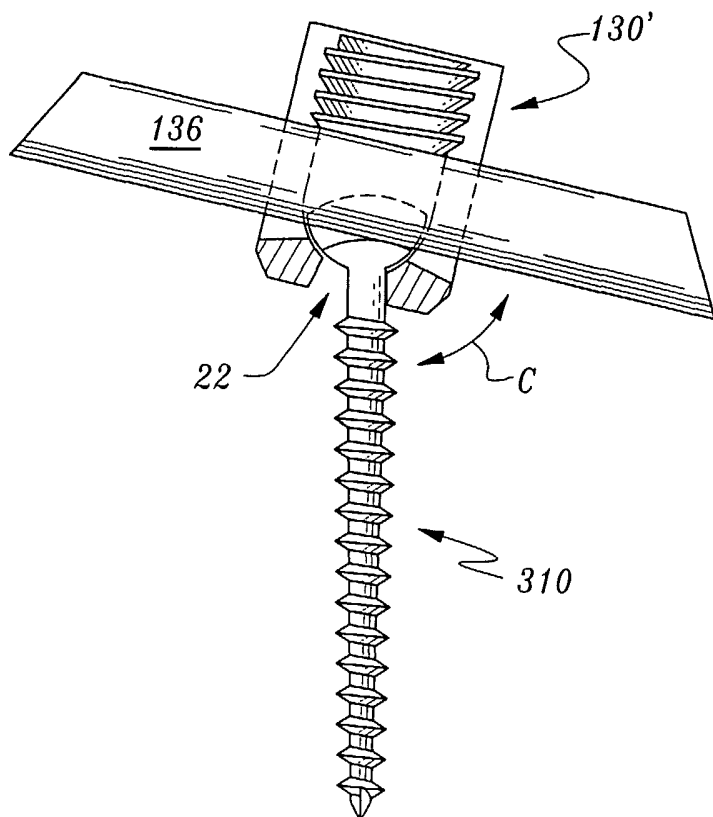

(57) Abstract: An orthopedic stabilization structure including a threaded fastener capable to articulation to accommodate various skeletal geometries, a rod, and a cup supporting said threaded fastener and said rod to be subsequently held in fixed position with respect to the skeletal structure.



WO 03/032863 A2



TR), OAPI patent (BF, BJ, CF, CG, CI, CM, GA, GN, GQ, GW, ML, MR, NE, SN, TD, TG).

*For two-letter codes and other abbreviations, refer to the "Guidance Notes on Codes and Abbreviations" appearing at the beginning of each regular issue of the PCT Gazette.*

**Published:**

— *without international search report and to be republished upon receipt of that report*

## Title

# Orthopedic Stabilization Device and Method

## Technical Field

The instant invention is directed generally to devices used by orthopedic surgeons to stabilize and align skeletal structures. More specifically, the instant invention includes a fastener capable of rotation about an axis within a supporting cup, the cup contoured to receive a rod therein and a means to fix the rod and rotationally oriented fastener in a fixed position. In addition, the instant invention includes a fastener that utilizes radial and axial forces to fix it in position without use of a rod or of rotationally capable fasteners.

## Background Art

Orthopedic procedures involving stabilization of skeletal structure presently suffer from two common frailties: the first is the inability to orient the stabilizing structure for a multiplicity of common angulations and the second is the failure to provide a reliable thread portion which engages bone of the patient.

## Disclosure of Invention

The instant invention provides the ability to address various skeletal components in a relational way by allowing articulation of the device in a multiplicity of angulations and to fasten to the skeletal structure to provide greater stabilization with an improved thread pattern which provides both axially compressive forces along the length of the fastener and radially inward drawing forces.

## Industrial Applicability

The industrial Applicability of this invention shall be demonstrated through discussion of the following objects of the invention.

Accordingly, it is a primary object of the present invention to provide an orthopedic stabilization structure.

A further object of the present invention is to provide an improved threaded portion therefore.

A further object of the present invention is to accommodate a plurality of angulations when addressing a skeletal structure.

Viewed from a first vantage point, it is an object of the present invention to provide an orthopedic device, comprising, in combination: a threaded shaft, the shaft having one terminus with rotational means, a cup having a rotational means receiving area dimensioned to allow rotation of the threaded shaft about the one terminus, the cup having a transverse slot, a rod passing through the slot, and means to fix the rod and the threaded shaft into a fixed position relative to the cup.

Viewed from a second vantage point, it is an object of the present invention to provide a method for supporting a skeletal structure, the steps including: deploying fasteners with support cups; deploying a support rod; orienting the cups so the rod abuts the fasteners; and fixing the rod and fasteners together.

Viewed from a third vantage point, it is an object of the present invention to provide an orthopedic device, comprising, in combination: a fastener having a threaded body and a top portion provided with a saddle; the saddle having an upper face and a lower face; the upper face contoured to receive a rod thereon; and the lower face including a seating area for reception within a cup whereby the fastener can articulate within the cup.

Viewed from a fourth vantage point, it is an object of the present invention to provide an orthopedic fastener, comprising in combination: a shaft having a first thread pattern at one end and a second thread pattern at another end, one thread pattern having means to draw radially inward bone within which it is embedded.

Viewed from a fifth vantage point, it is an object of the present invention to provide a method for deploying an orthopedic fastener, the steps including inserting the fastener to induce axial compressive forces and radially inwardly directed forces with respect to the fastener.

Viewed from a sixth vantage point, it is an object of the present invention to provide an orthopedic device, comprising, in combination: a support rod; a plurality of fastener supports attached to the support rod; and a plurality of fasteners coupled with the plurality of fastener supports, wherein the fasteners include a threaded body and means to mate with the fastener supports in a fixed orientation, wherein subsequent movement of the fasteners is prevented by the interaction of the fastener supports and the means to mate with the fastener supports.

Viewed from a seventh vantage point, it is an object of the present invention to provide an orthopedic device, comprising, in combination: a clamp having means to receive and secure a support member and means to mate with and secure a fastener, the fastener having a threaded body and complementary means to mate with and be

secured by the clamp, and wherein the fastener includes means to mate with the clamp in a finite number of orientations.

Viewed from a eighth vantage point, it is an object of the present invention to provide an orthopedic device, comprising, in combination: a clamp having means to receive and secure a first support member and means to receive a second support member, wherein the second support member includes a support cup containing a fastener and means to allow rotational movement of the fastener in the support cup.

Viewed from a ninth vantage point, it is an object of the present invention to provide an orthopedic device, comprising, in combination: a clamp having means to receive a support member and means to mate with a fastener, wherein the means to mate with the fastener includes a split shaft, wherein the split shaft is an extension of the means to receive a support member, the fastener having a threaded body and complementary means to mate with the clamp, and wherein the fastener includes means to mate with the clamp in a finite number of orientations; and securing means, the securing means mating with the fastener to secure the support member in the clamp and to secure the fastener to the clamp by means of compression of the split shaft.

These and other objects will be made manifest when considering the following detailed specification when taken in conjunction with the appended drawing figures.

### **Brief Description Of The Drawings**

Figure 1 is a top view of the fastener.

Figure 2 is a side view of the fastener.

Figure 3 is a sectional view of the fastener geometry.

Figure 3A shows Figure 3 with a taper.

Figure 4 shows the fastener and stabilization structure.

Figure 5 is another view of Figure 4.

Figure 6 displays angulation of the Figure 4 structure.

Figure 7 details a bolt used in the structure.

Figure 8 details the bolt receiving area.

Figure 9 shows one side of the cup.

Figure 10 shows an adjacent side (90 degrees) relative to Figure 9, showing a diametrical slot.

Figure 11 is a top view of figures 9 and 10.

Figure 12 is a bottom view of Figures 9 through 11.

Figure 13 is a sectional view of Figure 9 along lines 13-13.

Figure 14 is a sectional view similar to Figure 4.

Figure 15 adds a fastener and rod to Figure 14.

Figure 16 adds a fixing bolt to Figure 15.

Figure 17 shows the device deployed by way of example.

Figure 18 shows an alternative thread pattern.

Figure 19A and B show the bolt of the earlier drawings modified to include a stem.

Figure 20 is a perspective of a clamp to be used with the Figure 19 stem.

Figure 21 shows the clamp mounted on the stem.

Figure 22 shows two clamps on the stem from one side.

Figure 23 shows two clamps on the stem from another side.

Figure 24 shows a deployment of Figures 18 through 23.

Figure 25 illustrates angulation of Figures 22 and 23.

Figure 26 is an alternative fastener to that which is shown in Figure 1.

Figure 27 is a perspective of Figure 26.

Figure 28 is a side section of a cup for use with Figures 26 and 27.

Figure 29 is another side section of Figure 28.

Figure 30 shows the Figure 26 fastener deployed in the Figure 28 cup with a fixing rod.

Figure 31 is a second view of Figure 30.

Figure 32 is a side view of Figure 26.

Figure 33 is a view of Figure 30 with a threaded bolt deployed.

Figure 34 shows Figure 33 from the side.

Figure 35 shows Figure 34 angulated.

Figure 36 is a view of one fastener with a drive head.

Figure 36A is a top view of another fastener drive.

Figure 36B is a top view of a third fastener drive.

Figure 37 is a view of a longer fastener having an unthreaded medial shaft portion.

Figure 38 is one example of a deployment of the Figure 36 fastener.

Figure 39 is an alternative to Figure 36.

Figure 40 is an alternative to Figure 37.

Figure 41 shows one example of the Figure 39 and 40 fasteners deployed.

Figures 42A and 42B are side views of an alternate embodiment of a fastener having a hollow top portion.

Figure 43A is a side view of a rod holder that mates with the Figure 42 fastener.

Figure 43B is an end view of a rod holder that mates with the Figure 42 fastener.

Figure 44 shows the Figure 42 fastener mated with the Figure 43 holder.

Figures 45A and 45B are side views of another embodiment of a fastener having a hollow top portion.

Figure 46A is a side view of a rod holder that mates with the Figure 45 fastener.

Figure 46B is an end view of a rod holder that mates with the Figure 45 fastener.

Figure 47 shows the Figure 45 fastener mated with the Figure 46 holder.

Figure 48 is a view of a fastener embodiment having an extended hexagonal top mated with a corresponding holder.

Figure 49A is a top view of the Figure 48 assembly attached to a threaded rod having micro-adjustment stabilization means.

Figure 49B is a side view of another fastener embodiment attached to a threaded rod having micro-adjustment stabilization means.

Figure 50 is another embodiment of the threaded fastener.

Figure 51 is a rod holder that mates with the Figure 50 fastener.

Figure 52 shows the Figure 50 fastener mated with the Figure 51 holder.

Figures 53A and 53B show a deployment of figures 50 through 52 with a rod.

### **Best Mode(s) for Carrying Out the Invention**

Considering the drawings, wherein like reference numerals denote like parts throughout the various drawing figures, reference numeral 100 is directed to the orthopedic stabilization device according to the present invention.

The device 100 allows a threaded fastener 10 to move about the arrow C as shown in Figure 4 such that although the long axis of the threaded shaft is depicted as presently aligned, it can be rotated and skewed from a vertical long axis of a cup 130 as in Figure 6. A rotational means 120 embodied as a disc has a cylindrical outer face 122 and planar top and bottom faces 124, 126. Thus, rotation about the arrow C occurs about a geometrical center 128. The disc 120 is integrally fixed to fastener 10. The rotational means 120 is constrained within a cup 130 having a central bore 132, an upper portion of which is provided with threads 111. In addition, a transverse slot 134 is cut along a diameter of the cup which allows slideable insertion therein of both the fastener 10 and integral disc 120 as well as a rod 136 transverse to a long axis of the cup 130. Please see Figures 9 through 16. The rod may have any of various cross-sectional profiles (e.g., square, circular, elliptical, etc.). The cup 130 is dimensioned such that the

rotational means 120 is in tangential registry along one cylindrical face 122 with the rod 136. The threaded bore 132 receives a threaded fixing bolt 110 therewithin to press the rod 136 against the rotational means 120 to fix their relative relationship once appropriate orientation has occurred.

In its essence, the fastener 10 includes a threaded shaft 32 having a first thread pattern 12 at one end and a second thread pattern 14 at an opposite end. As shown in Figures 1 and 2, the first end thread pattern 12 terminates in a point 16 and the threads increase in diameter to form a thread pattern with its spiral increasing as it extends away from the point 16.

The second thread pattern 14 has a larger diameter but a similar thread contour which shall be discussed in detail infra. Preferably, the shaft 32 is of variable length and tapers and narrows from end 18 to point 16. Please see Figures 1 and 2.

A further nuance of the first and second thread patterns is that the first thread pattern 12 has a coarser thread than the second thread pattern 14 which is a finer thread. The point 16 is the point of initiation for insertion into a bone during an orthopedic procedure. To facilitate same, a pilot hole may be drilled in the bone but thereafter, because of the tapering nature of the first thread 12, this portion is thereafter self-threading. Notice that the crest 70 for both first and second thread patterns is sharp. This allows cutting into the bone which typically has a harder exterior than the interior. By providing a coarser thread pattern for the first thread 12, this thread will insert into the bone faster than the second thread pattern 14. As a consequence, when the bone begins to be engaged by the second thread pattern, an axial compression of the bone occurs along the direction of the two arrows A. In addition, because of the thread geometry, the threads will exert a radially inwardly directed force along the direction of the double-ended arrows B. Whereas in the prior art, conventional fasteners induced radially outwardly spreading (the opposite direction from arrow B), the instant invention provides radially inwardly or a drawing force B as well as the compressive force A.

The threads 60 of fastener 10 for threads 12 and 14 are actually one continuous helically wound thread which begins at the ends and spirals towards the medial portion of shaft 32 as it migrates from the ends. Please see Figure 3.

The threads 60 include a sharpened crest 70 defining a major diameter 62 of the threads and a root 80 defining a minor diameter 64 of the threads 60. As shown in detail in figure 3, the threads 60 have an upper surface 66 which extends from a bottom edge 84 of the root 80 to the sharpened crest 70. The threads 60 also include a lower



surface 68 which extends from a top edge 82 of the root 80 to the sharpened crest 70. Both the upper surface 66 and lower surface 68 angle toward the medial portion of the fastener as the surfaces 66, 68 extend from the root 80 to the crest 70.

In section, the surfaces 66, 68 extend linearly from the root 80 to the sharpened crest 70. However, as this contour is rotated helically about the threaded shaft 32 along with the threads 60, the upper surface 66 and lower surface 68 take on a curved surface appearance. This appearance is similar to that which would be formed by a linear section of the surface of a cone with a tip of the cone oriented downward and the cone rotated and translated upward along a central axis thereof. The upper surface 66 and lower surface 68 thus have a curved surface in three dimensions similar to that of a cone, but a linear character when viewed in section.

The upper surface 66 extends from the root 80 to the sharpened crest 70 at an upper surface angle  $\alpha$  diverging from a reference plane orthogonal to the central long axis 2 of the fastener. The upper surface angle  $\alpha$  is preferably  $20^\circ$  but could be any angle between  $0^\circ$  and  $90^\circ$ . The lower surface 68 extends from the root 80 to the sharpened crest 70 at a lower surface angle  $\beta$  with respect to the reference plane. The lower surface angle  $\beta$  is preferably  $40^\circ$  but could vary between  $0^\circ$  and  $90^\circ$ .

The upper surface angle  $\alpha$  is preferably less than the lower surface angle  $\beta$ . In this way, the threads 60 are provided with greater thickness and hence greater strength adjacent the minor diameter 64 than at the major diameter 62 and are thus more capable of bearing the loads experienced within the bone.

It is the angulation of the surfaces, especially upper surface 66 which encourages the radially inward force. When the upper and lower thread patterns are combined, axial compressive forces can be seen. Note the flat wall 54 of Figure 3. This could replace point 16 and require a deeper pilot hole.

The second thread portion 14 has the same figure 3 geometry except that the threads 60a are inverted, and as mentioned earlier are a finer thread (greater threads per inch axially) than the first thread portion 12. In other words Figure 3 would be viewed upside down for threads 14.

Figure 3A shows a section of thread with a pronounced taper. For thread pattern 14, Figure 3A would be viewed upside down and with a reverse taper to that shown.

A bottom 129 of cup 130 (Fig. 4) has clearance 22 which extends within an included arc preferably approaching 90 degrees to allow a wide range of fastener 10 rotation about arrow C. Rotation beyond this clearance 22 is prevented by cup wall

structure 24 that survives both the clearance aperture 22 and the slot 134 that runs diametrically down two sides of the substantially cylindrical cup 100. Free ends 138 of the cup 100 need the support a bolt 110 (Fig. 16) to: (first) press the rod 136 in place by (second) applying pressure to the disc 120 and retaining it by (third) uniting the free ends 138.

The threads 60 of the threaded bolt 110 (Figs. 7 and 16) are actually one continuous helically wound thread which begins at the bottom 54 and spirals up to the top 52. While this single thread design is preferred, other arrangements including compound series of threads which wind helically together from the bottom 54 to the top 52 could also be utilized.

The threads 60 include a crest 170 defining a major diameter 62 of the threads and root 80 defining a minor diameter 64 of the threads 60. As shown in detail in Figure 7, the threads 60 have an upper surface 66 which extends from a bottom edge 84 of the root 80 to the upper edge 72 of crest 170. The threads 60 also include a lower surface 68 which extends from a top edge 82 of the root 80 to a lower edge 74 of the crest 170. Both the upper surface 66 and lower surface 68 angle upwards as the surfaces 66, 68 extend from the root 80 to the crest 170. Both the crest 170 and root 80 exhibit a constant distance from the central axis 2 between the top edge 82 and the bottom edge 84. Compared to Figure 3, crest 170 is blunt, while crest 70 is sharpened. Also, bolt 110 and thread 111 could have sharp contours like crest 70 (replacing crest 170) and vice versa.

In section, the surfaces 66, 68 extend linearly from the root 80 to the crest 170. However, as this contour is rotated helically about the threaded bolt 110 along with the threads 60, the upper surface 66 and lower surface 68 take on a curved surface appearance. This appearance is similar to that which would be formed by a linear section of the surface of a cone with a tip of the cone oriented downward and the cone rotated and translated upward along a central axis thereof. The upper surface 66 and lower surface 68 thus have a curved surface in three dimensions similar to that of a cone, but a linear character when viewed in section.

The upper surface 66 extends from the root 80 to the crest 170 at an upper surface angle  $\alpha$  diverging from a reference plane 4 orthogonal to the central axis 2. The upper surface angle  $\alpha$  is preferably 20 degrees but could be any angle between 0 degrees and 90 degrees. The lower surface 68 extends from the root 80 to the crest 170 at a lower surface angle  $\beta$  with respect to the reference plane 4. The lower surface angle  $\beta$  is preferably 40 degrees but could vary between 0 degrees and 90 degrees.

The upper surface angle  $\alpha$  is preferably less than the lower surface angle  $\beta$  such that a thickness of the threads 60 at the crest 170 is less than a thickness of the threads 60 between adjacent roots 80. In this way, the threads are provided with greater thickness and hence greater strength adjacent the minor diameter 64 than at the major diameter 62 and are thus more capable of bearing the loads experienced within the threaded bore 132.

Referring now to Figure 8, details of the threaded bore 132 on free ends 138 bore are shown. The bore is preferably substantially complementary in form to the threaded shaft of the bolt 110. The bore includes threads T. The thread geometry of the bolt 110 and threads T draw free ends 136 of cup 130 together along arrow D.

Figure 17 shows a fractured bone and the device 100 being applied. The fasteners 10 with discs 120 and the cups 130 are located such that the fasteners 10 are located in the bone, but the disc can rotate within clearance 22 as described. Recall the threads 12, 14 axially compress and radially inwardly drawing in the bone. Next the rod 138 is placed within the slots 134 of the cups 130.

The rod is shown as having a bend 165 to demonstrate the system's versatility. Next the bolts 110 are threaded into threads 111 in the free ends 138 of the cups 130. As the bolts 110 bear on rod 136, the rod 136, disc 120 and fastener 10 become rigid. The free ends 138 also draw together tightly.

Figure 18 is a view similar to Figure 4 showing an embodiment where the first and second thread patterns have conventional geometry but the second thread pattern has a greater thread pitch density, defining finer threads than the first thread pattern.

Figures 19A and B are similar to Figure 16 except that the bolt 110 includes an elongate stem 112 projecting from a top of the bolt 110 and projects from the cup 130. The stem 112 may include a necked down area 113 adjacent bolt 110. Stem is preferably cylindrical while the necked down area 113 can be faceted to rotate stem 112 with a tool.

Figure 20 is a perspective view of a stem clamp 210 which fixes to stem 112. Clamp 210 includes a cylindrical bore 212 dimensioned to receive stem 112 and includes a slit 214 on an outer wall and is diametrically aligned with a groove 216 extending into the clamp body. Slit and groove collectively cooperate with a bore 218 passing through clamp 210 perpendicular to groove 216. When slit 214 and groove 216 are drawn together along arrow D, the stem 112 is fixed in position. Clamp 210 is substantially box shaped and includes a top surface 222 which is planar except for two outboard raised edgewalls 224 oriented parallel to the stem bore 212. The edgewalls 224 in conjunction with top surface 222 define a receiving slot dimensioned to receive a

projection 226 similar to the rectangular projection 226 shown in Figure 20 on the bottom surface. The projection 226 thus includes projection walls leading to the body of the clamp 210 such that the span between the edgewalls 224 equals the span of the projection between the projection walls 228. Note the projection 226 is offset from the top surface 222 (and its recess defined by edgewalls 224) by 90 degrees. This allows plural clamping blocks 210 to be stacked as shown in Figures 22 and 23 in a stable manner. A bolt 230, passing through plural bores 218 holds the clamps in place via a nut 232. Corners 203 of clamp 210 may be chamfered.

Figure 24 shows how this alternative embodiment uses the stem as an extension to accommodate the rod 136 discussed in Figure 17. Instead of rod 136 being interposed between disc 120 and bolt 110, the rod is received through one bore 218 of one clamp 210 mated as shown in Figure 23, while a second bore receives the stem 112. This embodiment favors external deployment of rod 136 external the body of a patient. To use the Figure 24 device, the fasteners 10 (with discs 120 and cups 130) are threaded along the bore. The stem 112 having the bolt 110 integral therewith is next threaded into the cup 130. The stems 112 are not yet tightened, allowing the cups to angulate (e.g. Figure 25) to follow the bone contour. The clamps 210 are next positioned on the stems 112 in pairs along with rod 136. The stems 112 are next tightened against disc 120 to fix the cups 130 by pressing the bolt 110 against the cylindrical outer face 122 of disc 120. Note that the geometry of the disc 120 and its placement in slot 134 prevents the fastener from working loose in the bone, particularly with the thread geometry 12, 14 discussed above. Next the rod 136, the clamps 210 and stems 112 are fixed in position by bolts 230 and nuts 232. At this point, the fracture (or other orthopedic anomaly) has been stabilized. While the necked down portion 113 may be faceted, the end 114 of stem 112 may have a drive head in lieu of or in addition to facets on stem 112.

Figures 26, 27 and 32 show front, perspective and side views, respectively, of an alternative fastener 310 compared to Figure 1. Similarities with earlier embodiments will not be belabored. Most notably, the rotational means 120 of Figure 1 has been replaced with a saddle 320. The saddle 320 has a radiused top surface 336 dimensioned to receive rod 136 (Figures 30 and 33) in tangential registry about approximately half the circumference of the rod 136. Thus, the radius of curvature of the saddle's top surface 336 matches the radius of curvature of rod 136. Compared to the Figure 4 arrangement, the saddle 320 enjoys greater surface contact with the rod 136. This results in less work being needed to hold the rod 136 and fastener 310 in a fixed position because of the greater contact area. Also, the overall length of the fastener is reduced

resulting in a shorter, more compact overall height of the device as shown for example in Figure 33 (compared to Figure 6) because a major portion of disc 120 has been substituted by the lower profile saddle 320 which in effect is an outer arc of a circle of the Figure 6 disk. As a consequence, cup 130' can also be made correspondingly shorter. Figures 27 and 32 show outer shoulders 338 of the saddle which have a curvature complimentary to its seat 340 (Figure 33) in the cup 130'. As before, clearance 22 allows relative rotation between the fastener 310 and the rod 136 and cup 130' about arrow C.

The threaded fastener 10 may be presented in various embodiments. The rotational means 120 of the threaded fastener 10 shown in Figures 1,2 may be replaced such that a remote end 18, proximate the second thread pattern 14 includes a driving head 18 which in the drawings is shown as hexagonal, but can be formed as an allen wrench recess 21 (Figure 36B), an oval drive head 20 which is also recessed (Figure 36A), or any other configuration to reliably drive the fastener. Thus, the threaded fastener 10 of Figures 36,37 has no rotational means. This threaded fastener 10 may be inserted directly into bone (Figure 38), either in lieu of or in conjunction with other threaded fasteners 10.

Figure 39 through 41 show a variation where the tapered shaft 32 uses the specialized threads 12 of the Figure 1 embodiment but conventional threads 114 on the second thread portion. The drive head 18 can be that of Figures 36, 36A, 36B or otherwise.

The conventional threads 114 mate with threaded bores 116 on a member 118 which may have a contour which follows the anatomy of the bone to be supported. Thus member 118 may have a compound contour as exemplified by the angulation 119. As shown, the thread 12 is embedded in the patient's bone. In the embodiment, the threads 12 coact with the threads 114 to provide the axial compression A and the threads 12 also provide the radically inward force B described in the earlier figures.

Alternatively, the rotational means 120 embodied as a solid disc in Figures 1,2 may be replaced by a hollow disc, as shown in Figures 42A-B,45A-B. The hollow may have a faceted profile, such as an octagonal profile 402A, another profile, such as a circular profile 404A circumscribed by teeth 406A, or any other profile allowing fixation of the threaded fastener 10. The fastener 10 of Figures 42A-B,45A-B slides onto a rod holder having a complementary profile 402B,404B to the hollow 402A,404A. The fastener 10 of Figures 45A-B additionally engages teeth 406B located on the end 420 of the rod holder. A rod 422 is held adjacent to the fastener 10 in a slot 424 on the rod holder. A

threaded portion 426 of the slot 424 mates with an external threaded shaft 428 that secures the assembly.

The fastener 10 of Figure 48 has an extended hexagonal bar portion 408A that mates with a hexagonal throughway 408B in a corresponding, complementally formed rod holder. The rod holder includes a slot 424 for a threaded rod 430 and threads 426 to engage a shaft 428. The assembly pictured in Figure 48 may be arranged such that one of the vertices 410 of the hexagonal bar 408A engage the threaded rod 430 and allow positional adjustment along the threaded bar 430.

Referring to Figures 49A-B, adjustment and stabilization means 432A,432B appear in pairs, one adjacent each side of the fastener 10 and holder assembly. Any of the fastener and holder assemblies pictured in Figures 4,21-23,33,44,47,48 may be used with the threaded bar 430 and adjustment and stabilization means 432A,432B.

Figure 50 is an embodiment of a threaded fastener 10 having a valley 450 that exhibits a multi-faceted profile 452 and terminates in threads 466. The corresponding socket (Figure 51) has a void 456 to contain a rod 462, the void 456 extending from the rod end 458 to the socket end 460. Thus, the socket end is not solid, but defines a split shaft 464. The socket end 460 connects to the rod end 456 by means of a clamping portion 454 that has a profile matching that of the multi-faceted profile 452 of the threaded fastener 10. The socket rests in the valley 450 of the fastener 10 (Figure 52). A threaded bolt 110 mates with the threads 466 atop the fastener 10. The pressure from the bolt 110 on clamping portion 454 and split shaft 464 secures the rod end 458 to the rod 462 in addition to securing the fastener 10 to the clamping portion 454. Figures 53A and 53B show the embodiment of Figures 50 through 52 deployed on a rod 462. Figure 53B shows the angulations relative to the rod 462 that are possible using the combination of the multi-faceted profile 452 of the fastener 10 and the clamping portion 454.

Moreover, having thus described the invention, it should be apparent that numerous structural modifications and adaptations may be resorted to without departing from the scope and fair meaning of the instant invention as set forth hereinabove and as described hereinbelow by the claims.

Claims

I Claim:

Claim 1 – An orthopedic device, comprising, in combination:

a threaded shaft, said shaft having one terminus with rotational means,  
a cup having a rotational means receiving area dimensioned to allow rotation of said threaded shaft about said one terminus,  
said cup having a transverse slot,  
a rod passing through said slot,  
and means to fix said rod and said threaded shaft into a fixed position relative to said cup.

Claim 2 - The device of claim 1 wherein said threaded shaft has first and second thread patterns thereon.

Claim 3 - A method for supporting a skeletal structure, the steps including:

deploying fasteners with support cups;  
deploying a support rod;  
orienting the cups so the rod abuts the fasteners;  
and fixing the rod and fasteners together.

Claim 4 - The device of claim 2 wherein said threaded shaft first and second thread patterns have differing thread pitch, such that said second thread pattern has finer threads than said first thread pattern.

Claim 5 - The device of claim 4 wherein said thread patterns have crests which are axially offset from their respective roots, inducing a radially inward directed force.

Claim 6 - The device of claim 5 wherein said first and second thread crests face each other inducing axial compressive forces.

Claim 7 - An orthopedic device, comprising, in combination:

a fastener having a threaded body and a top portion provided with a saddle;  
said saddle having an upper face and a lower face;  
said upper face contoured to receive a rod thereon; and  
said lower face including a seating area for reception within a cup whereby said fastener can articulate within said cup.

Claim 8 – An orthopedic fastener, comprising in combination:

a shaft having a first thread pattern at one end and a second thread pattern at another end,

one said thread pattern having means to draw radially inward bone within which it is embedded.

Claim 9 - A method for deploying an orthopedic fastener, the steps including inserting the fastener to induce axial compressive forces and radially inwardly directed forces with respect to the fastener.

Claim 10 - An orthopedic device, comprising, in combination:

a support rod;

a plurality of fastener supports attached to said support rod; and

a plurality of fasteners coupled with said plurality of fastener supports, wherein said fasteners include a threaded body and means to mate with said fastener supports in a fixed orientation, wherein subsequent movement of said fasteners is prevented by the interaction of said fastener supports and said means to mate with said fastener supports.

Claim 11 - An orthopedic device, comprising, in combination:

a clamp having means to receive and secure a support member and means to mate with and secure a fastener, said fastener having a threaded body and complementary means to mate with and be secured by said clamp, and wherein said fastener includes means to mate with said clamp in a finite number of orientations.

Claim 12 - An orthopedic device, comprising, in combination:

a clamp having means to receive and secure a first support member and means to receive a second support member, wherein said second support member includes a support cup containing a fastener and means to allow rotational movement of said fastener in said support cup.

Claim 13 - An orthopedic device, comprising, in combination:

a clamp having means to receive a support member and means to mate with a fastener, wherein said means to mate with said fastener includes a split shaft, wherein said split shaft is an extension of said means to receive a support member, said fastener having a threaded body and complementary means to mate with said clamp, and wherein said fastener includes means to mate with said clamp in a finite number of orientations; and

securing means, said securing means mating with said fastener to secure said support member in said clamp and to secure said fastener to said clamp by means of compression of said split shaft.



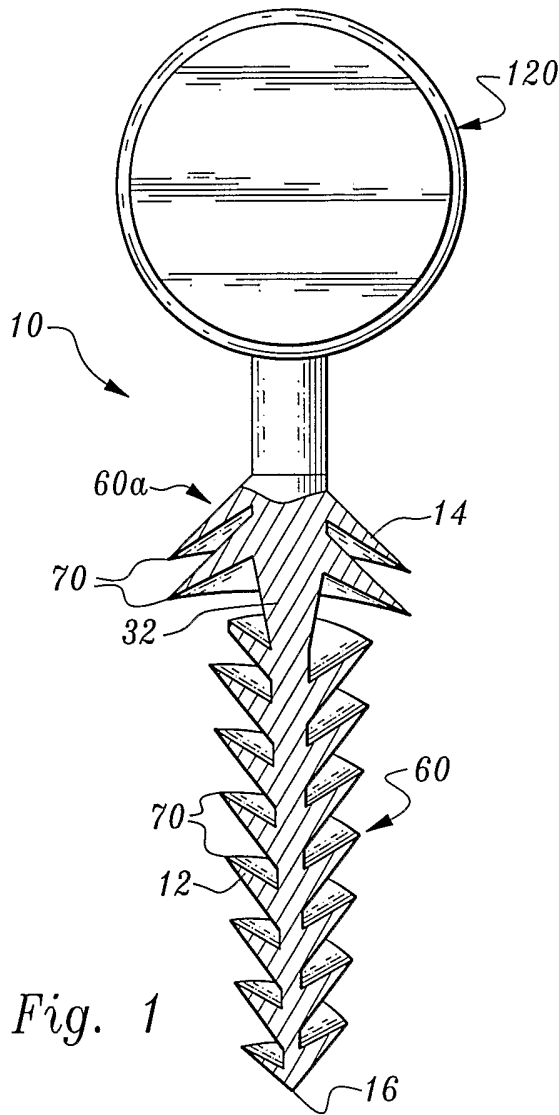

Fig. 1

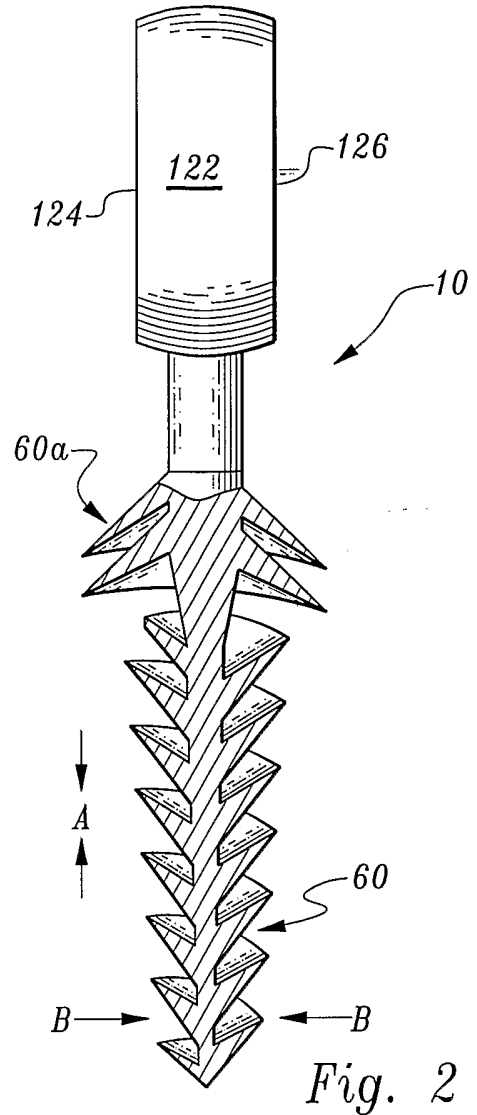

Fig. 2

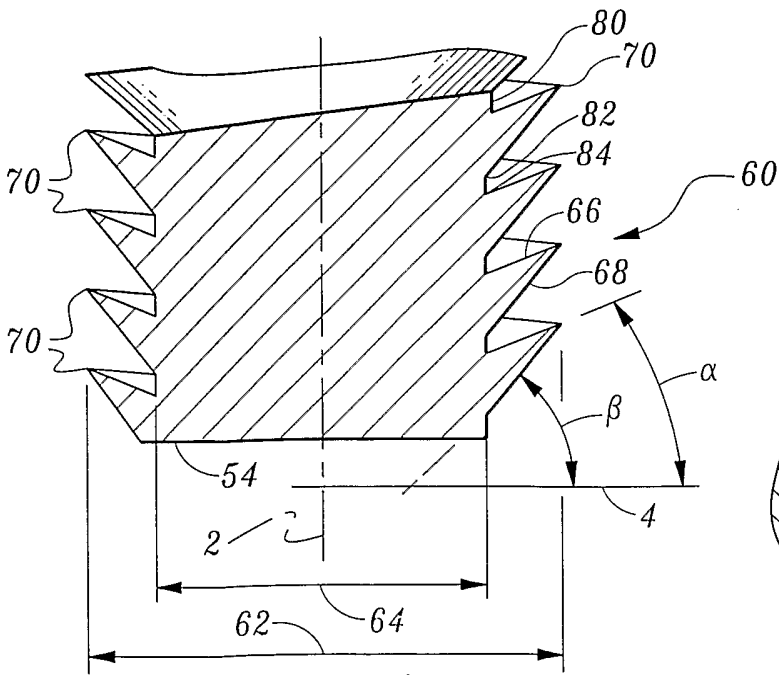

Fig. 3

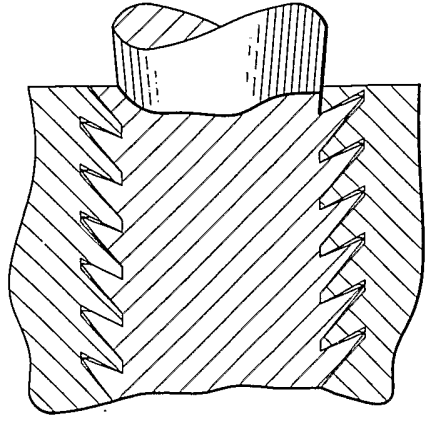

Fig. 3A

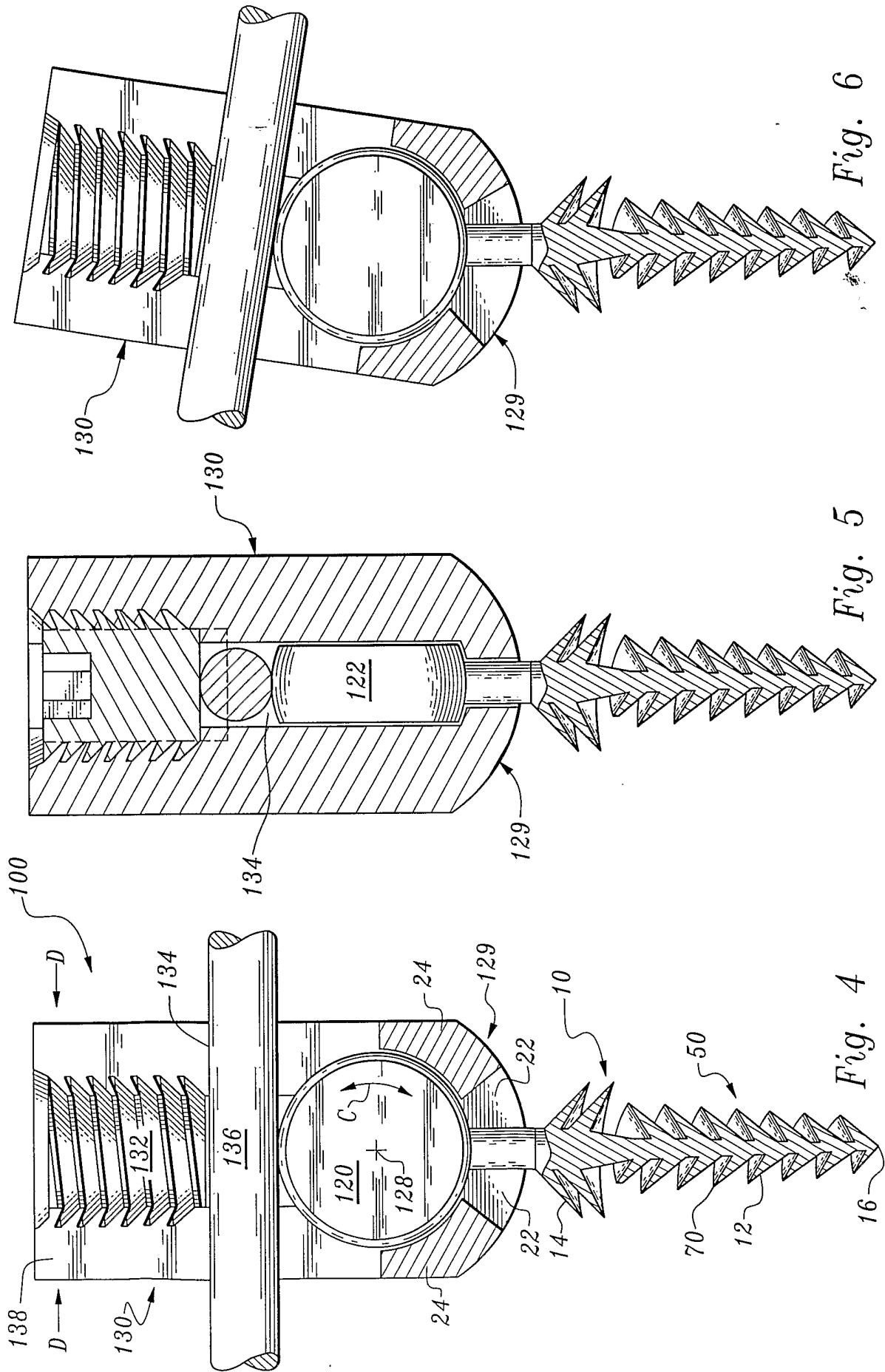

Fig. 6

Fig. 5

Fig. 4

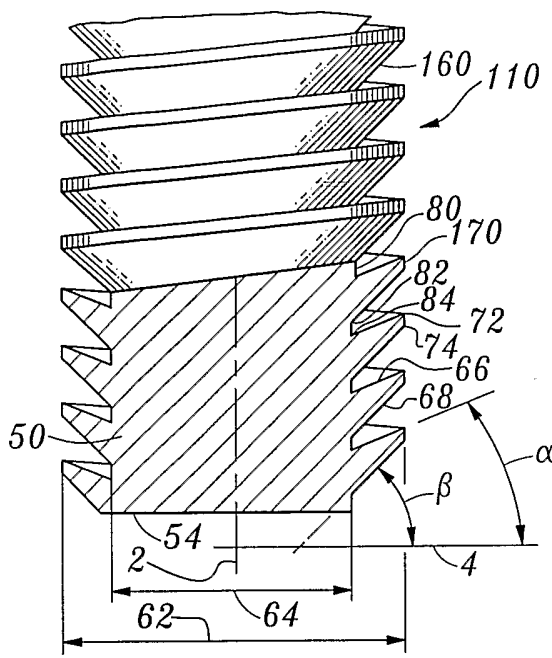

Fig. 7

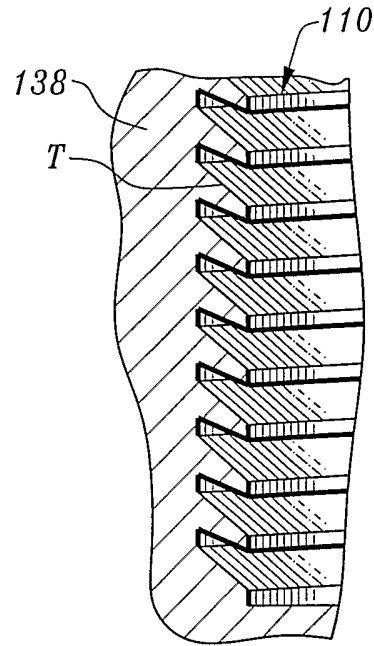

Fig. 8

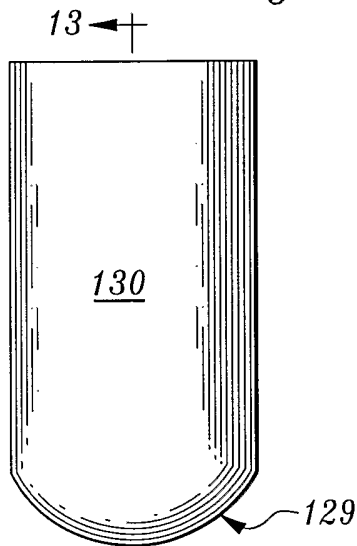

Fig. 9

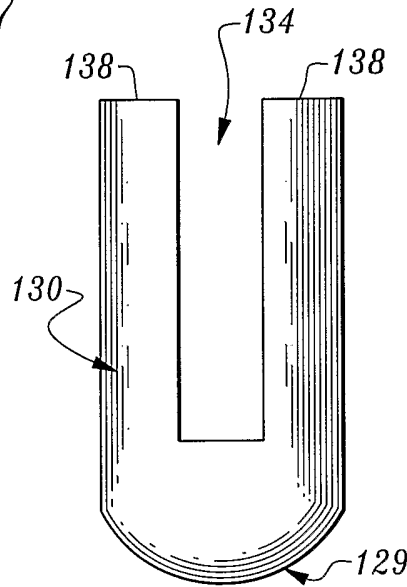

Fig. 10

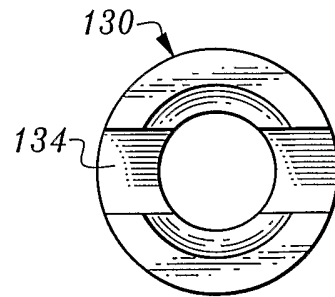

Fig. 11

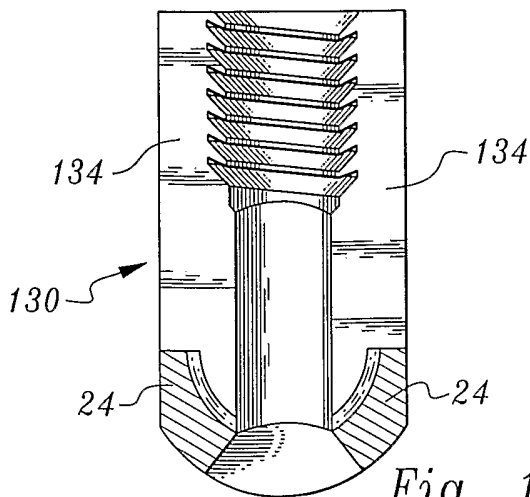

Fig. 13

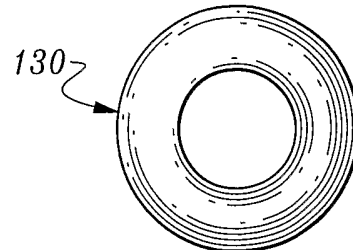

Fig. 12

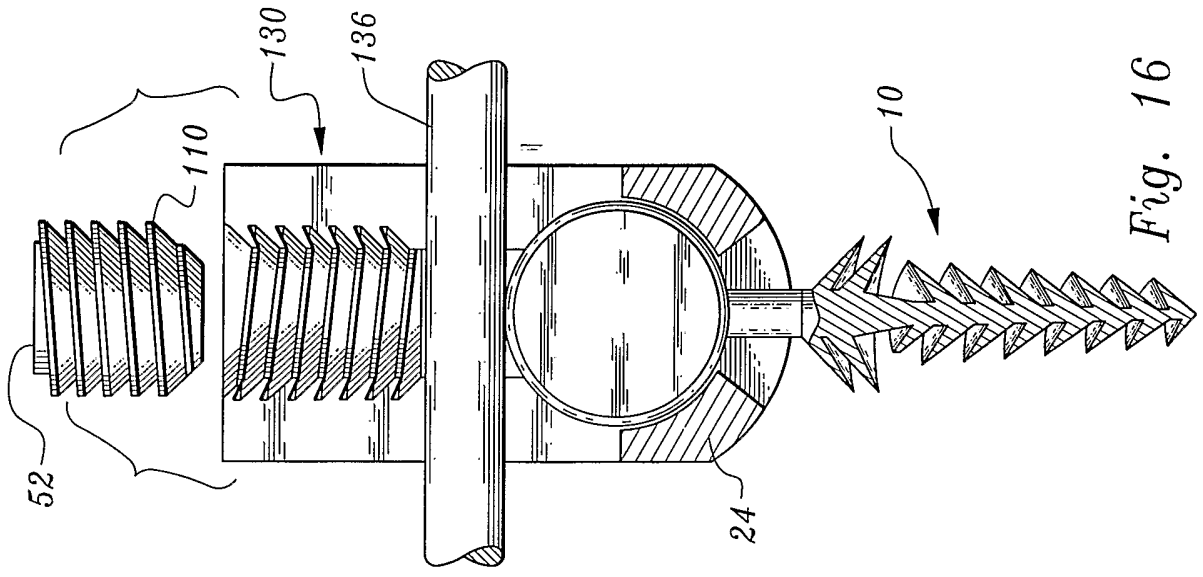

Fig. 16

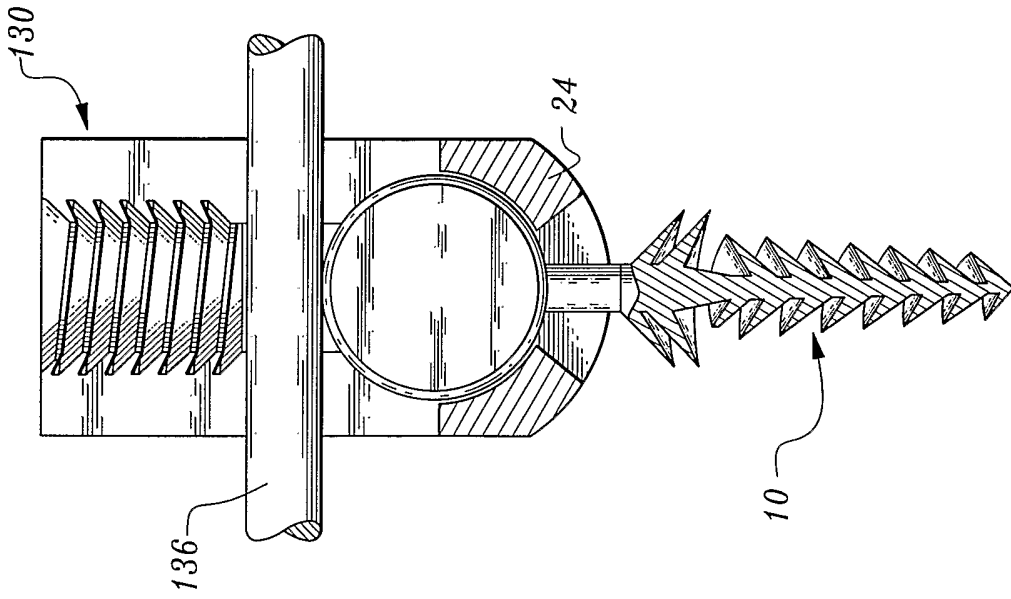

Fig. 15

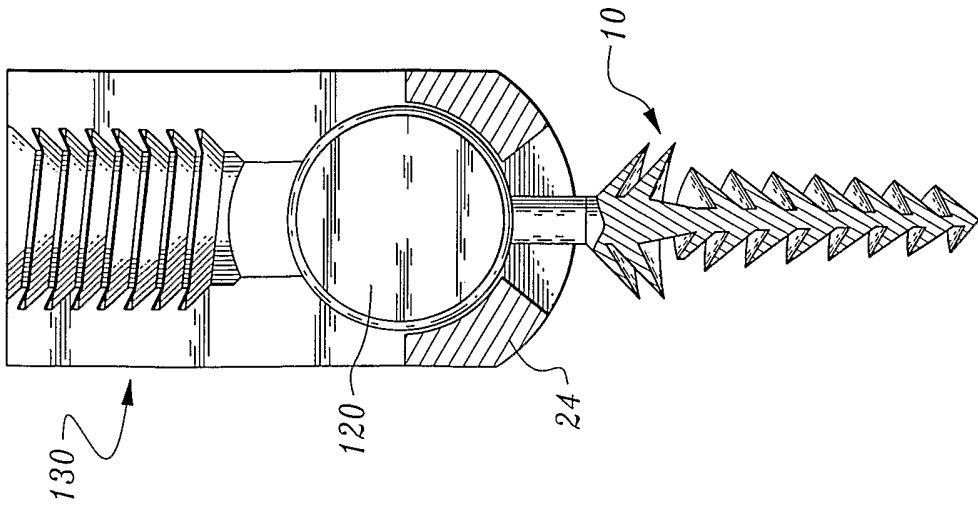

Fig. 14

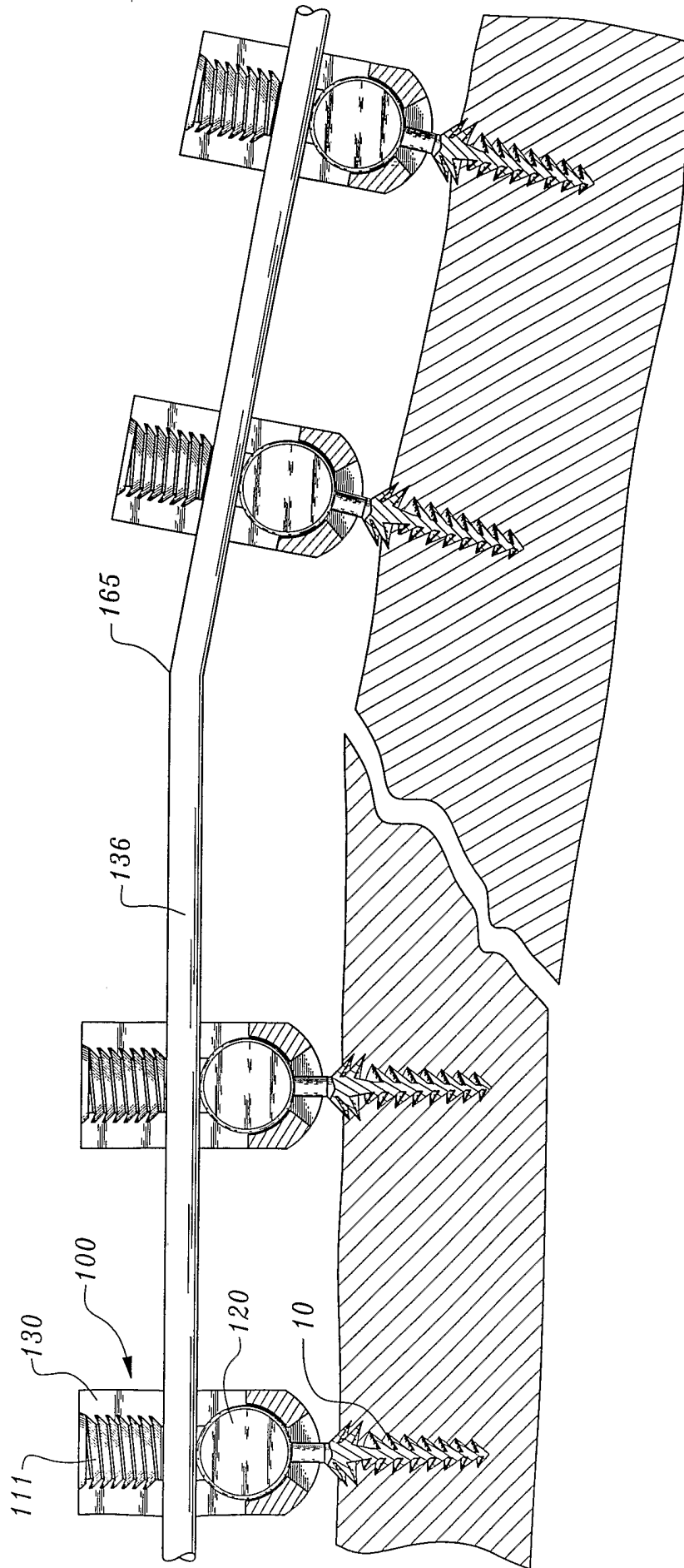

Fig. 17

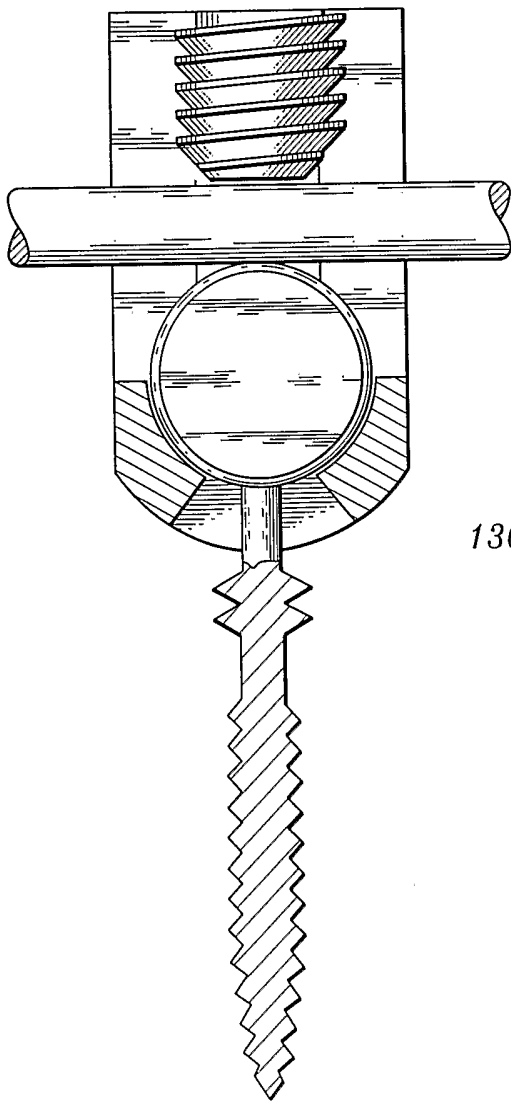
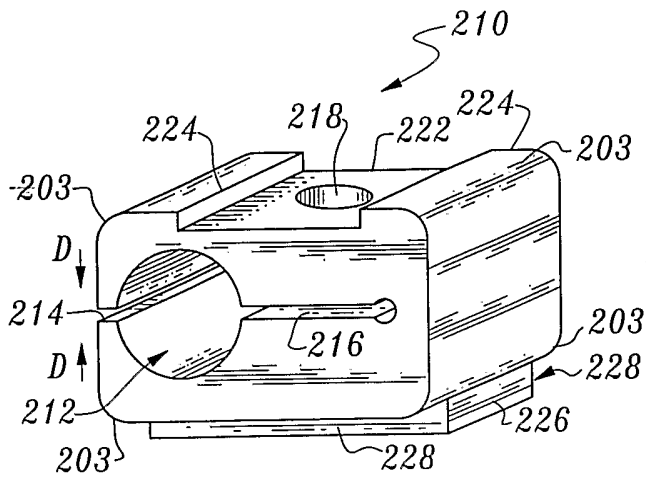
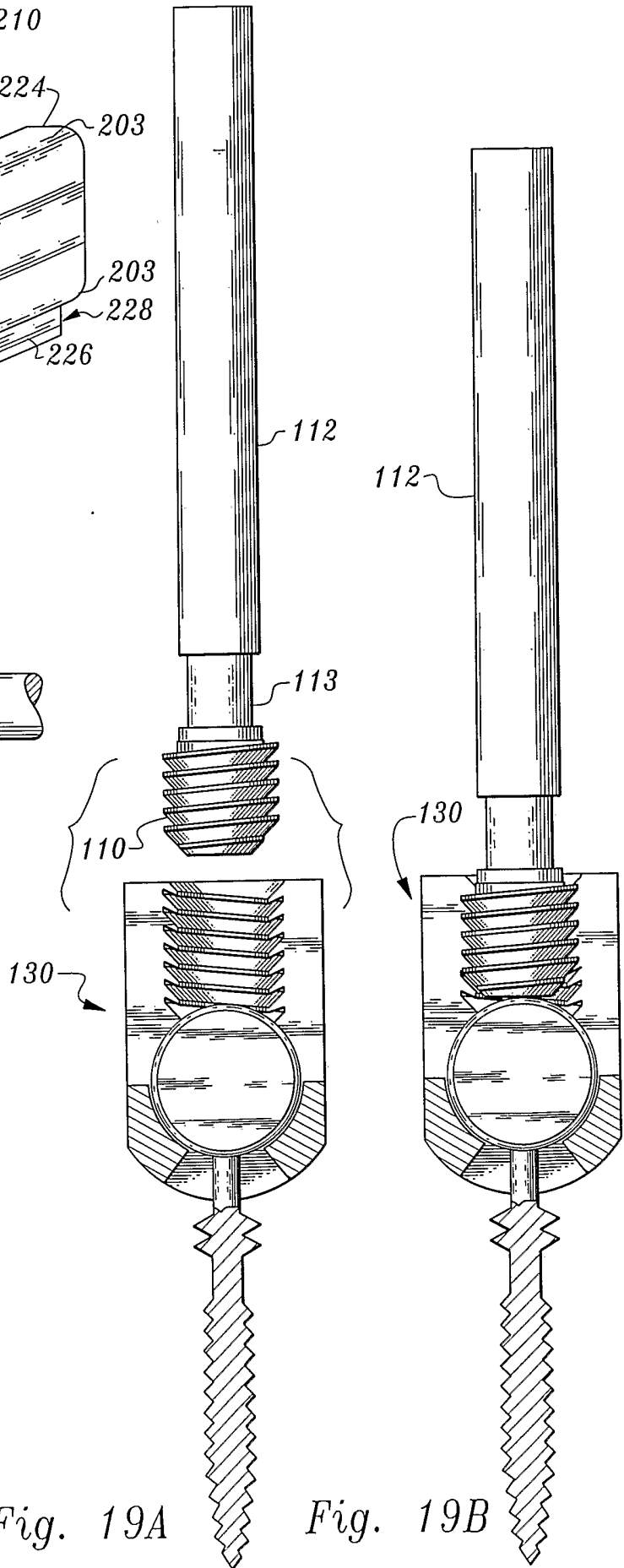

Fig. 18



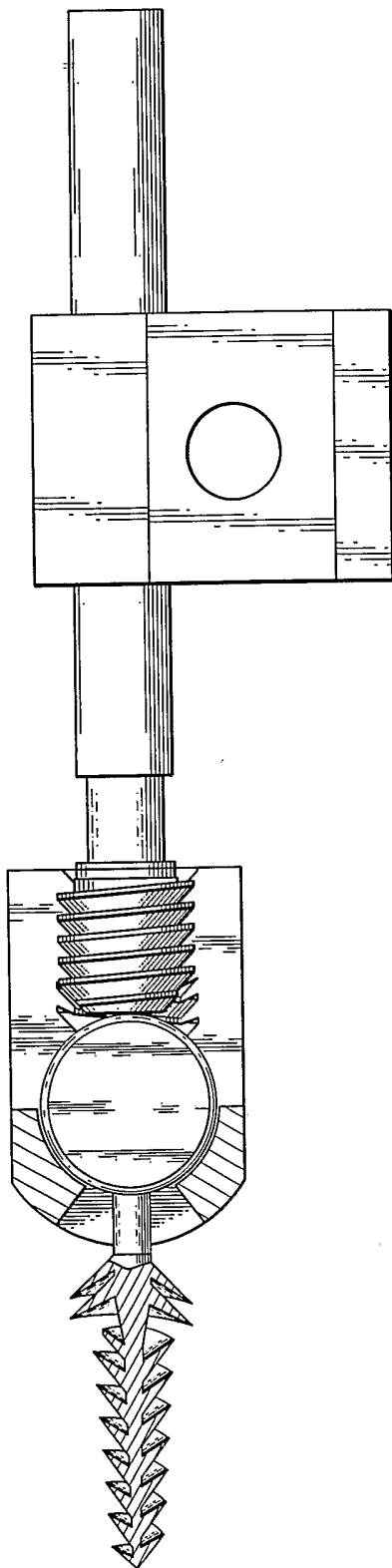

Fig. 21

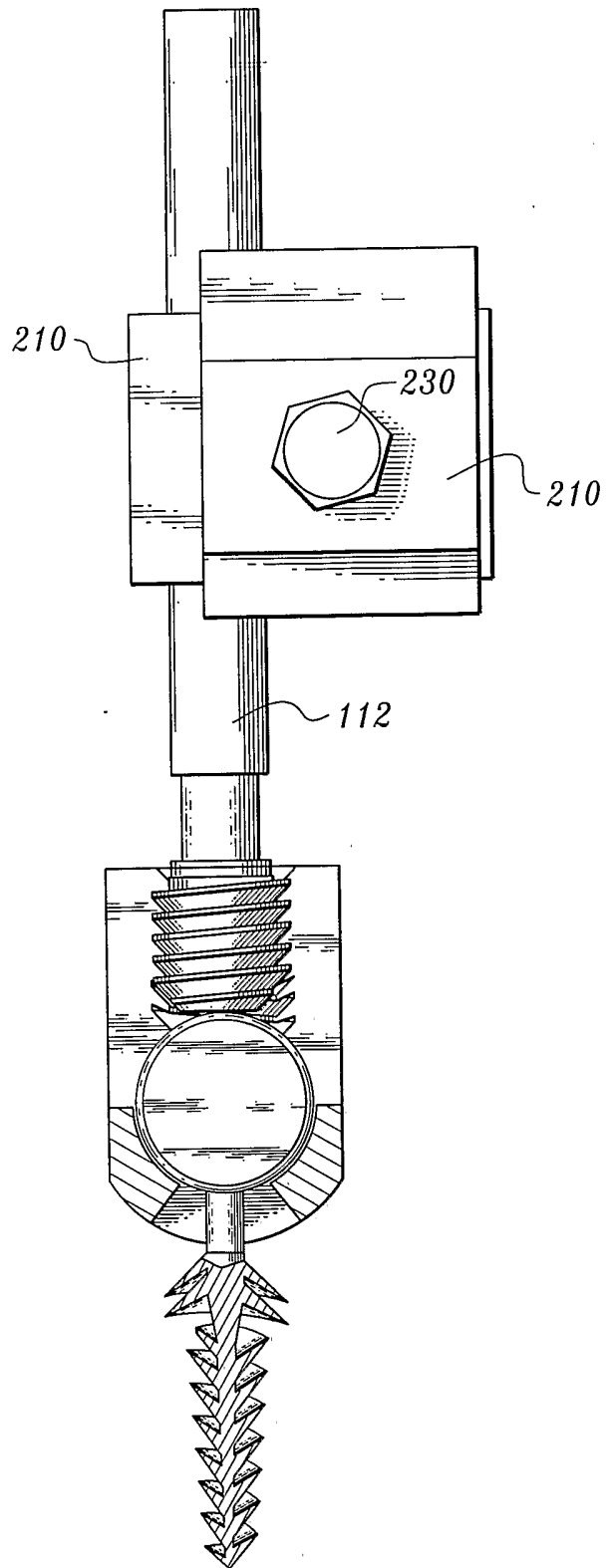

Fig. 22

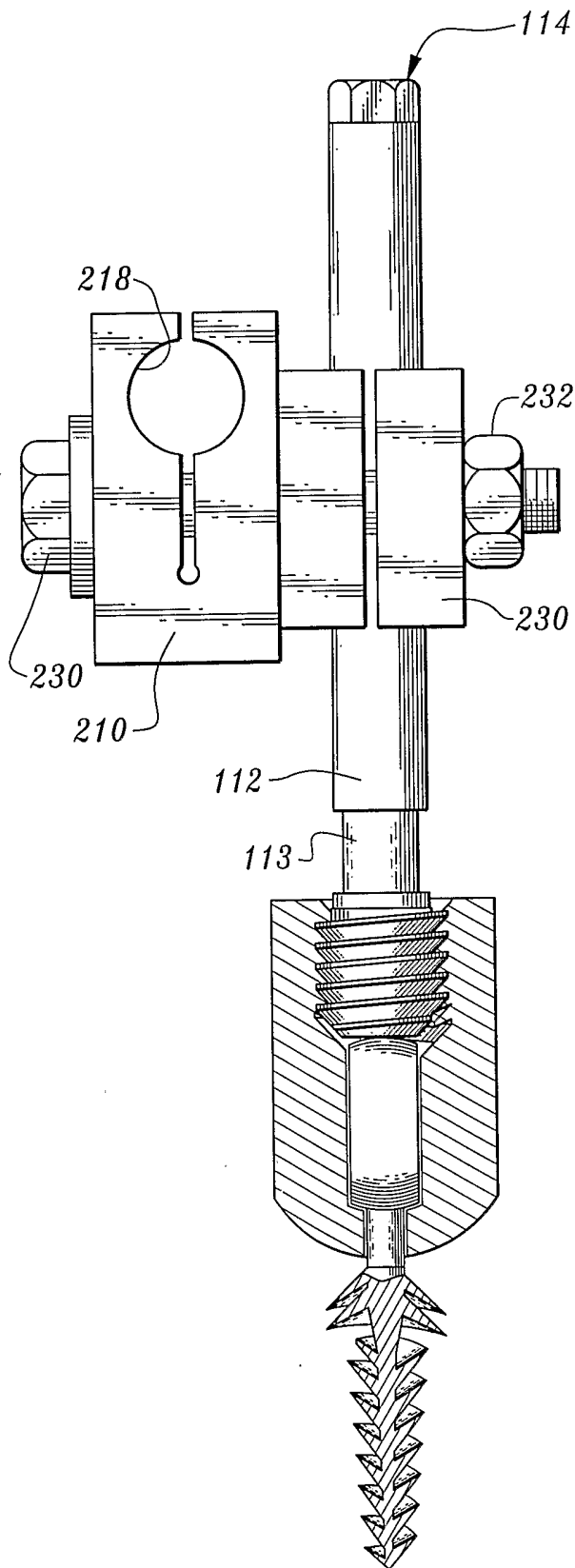

Fig. 23

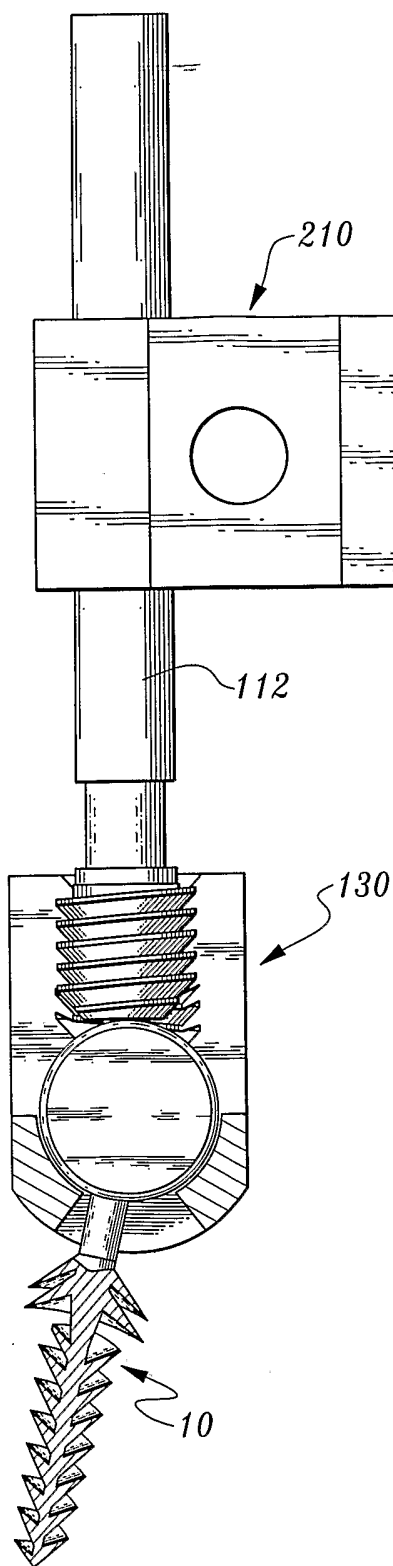

Fig. 25



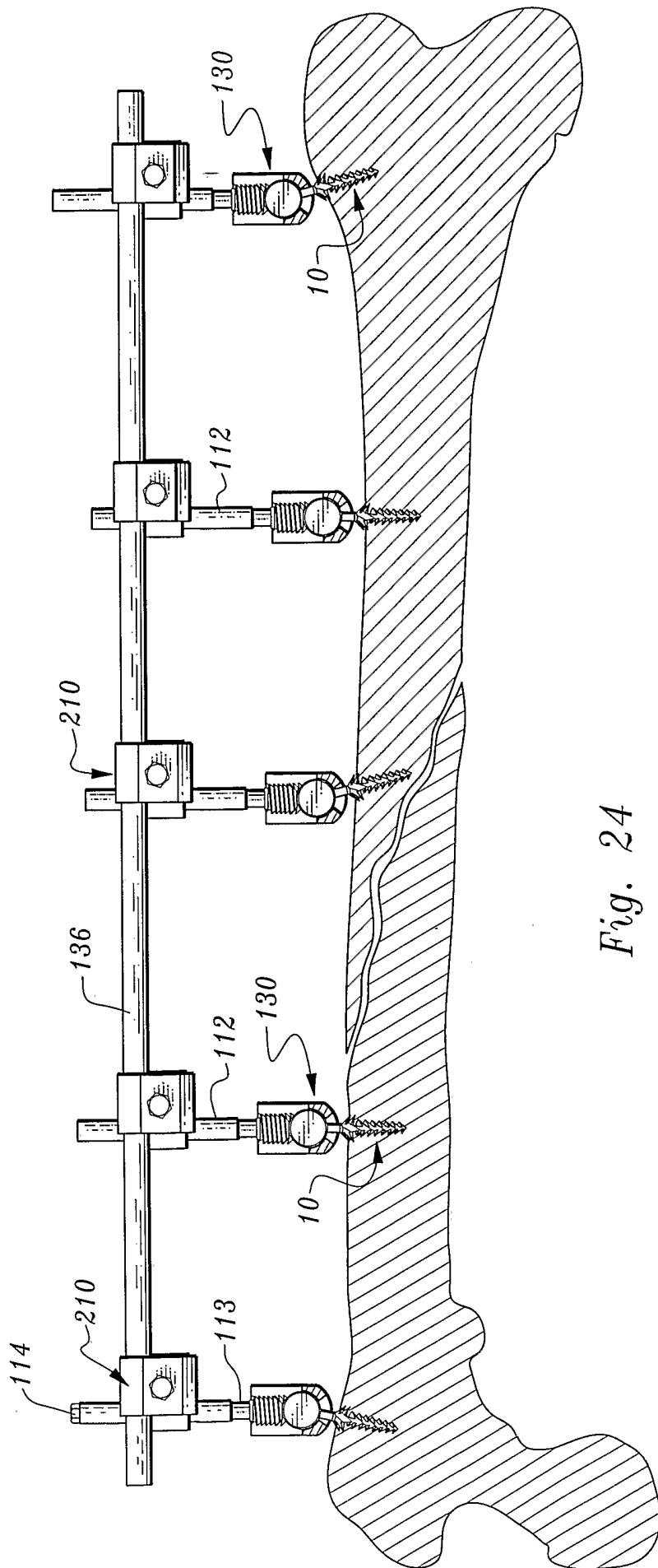

Fig. 24

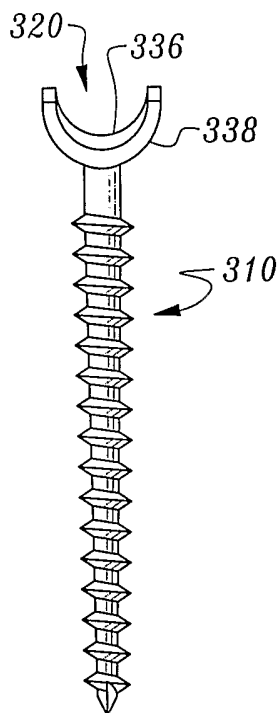

Fig. 26

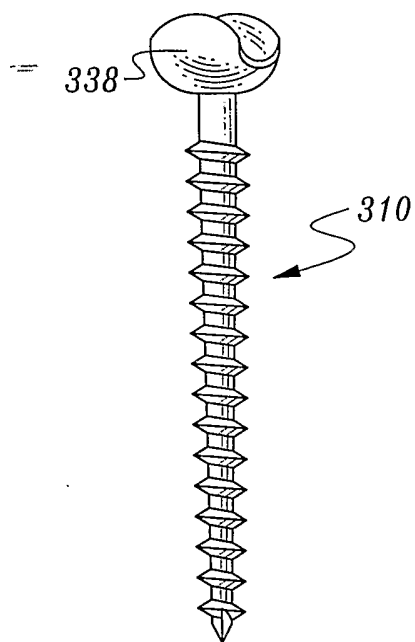

Fig. 27

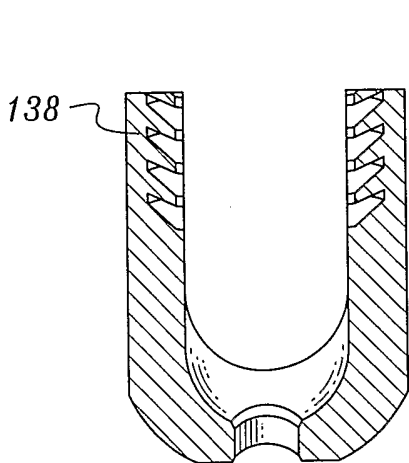

Fig. 28

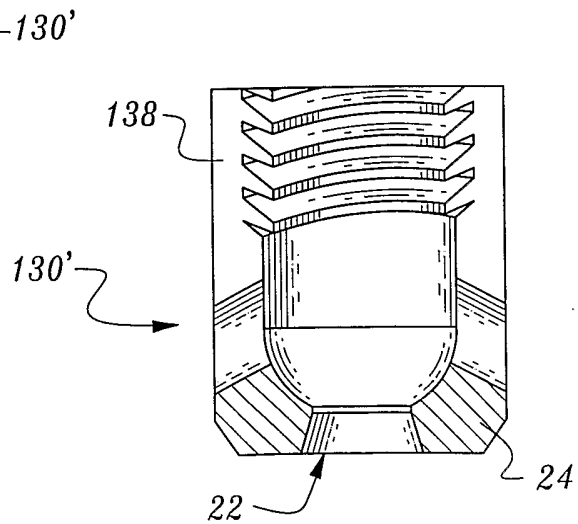

Fig. 29

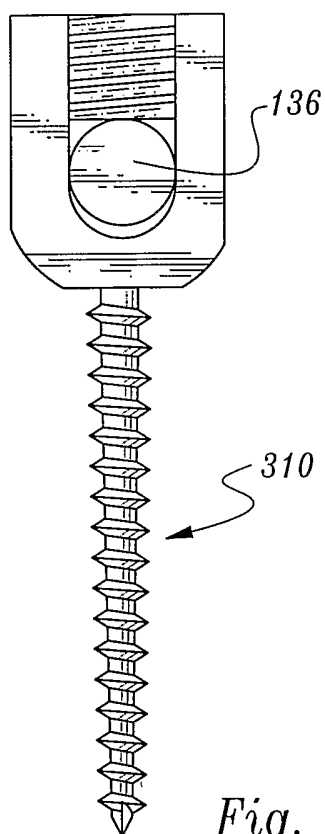

Fig. 30

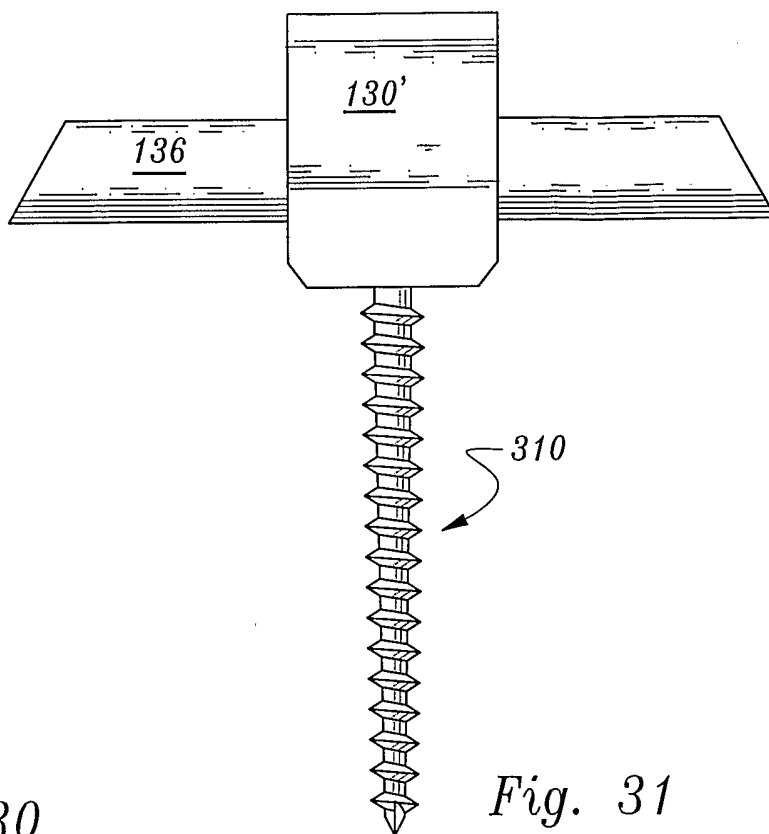

Fig. 31

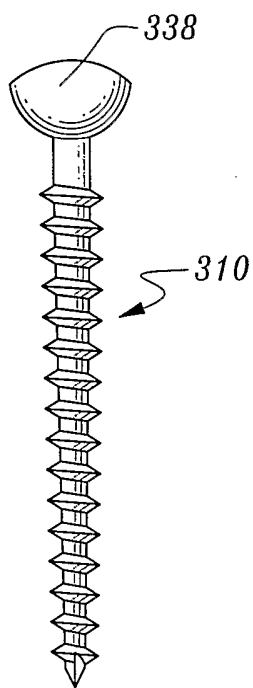

Fig. 32

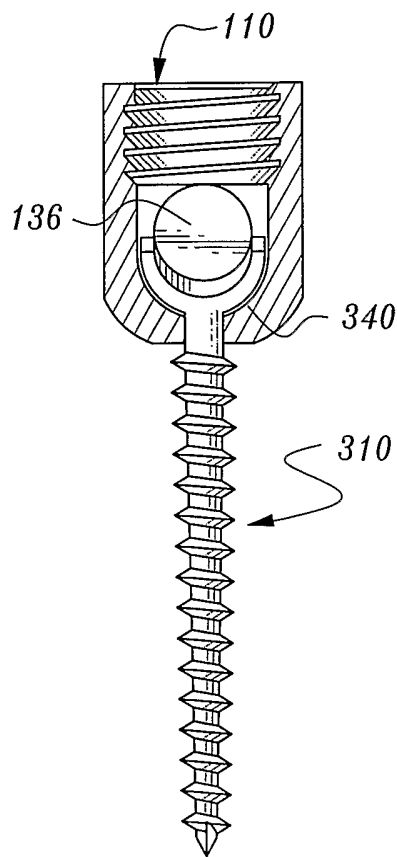

Fig. 33

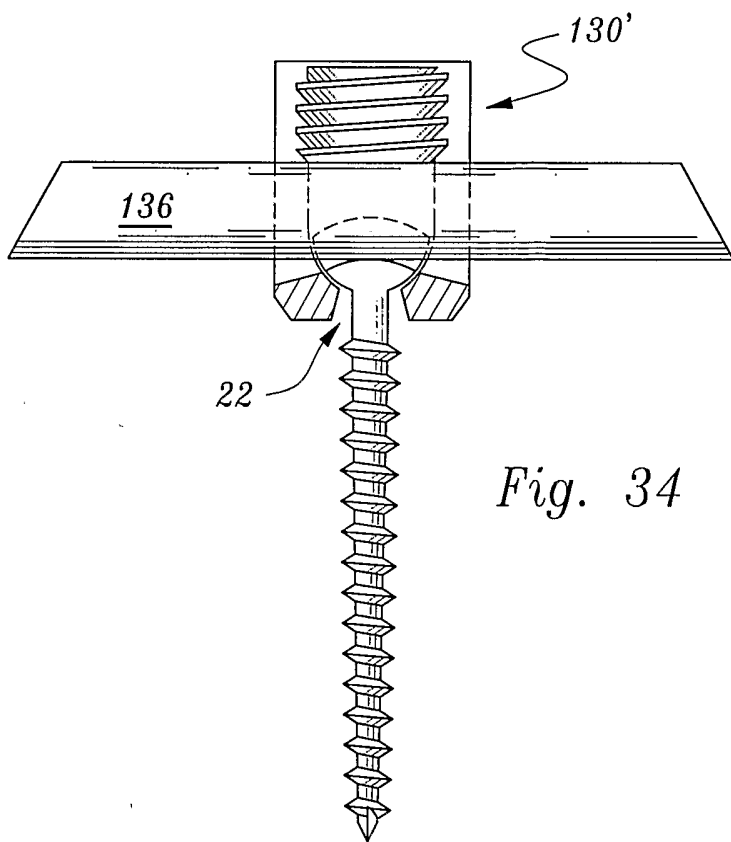

Fig. 34

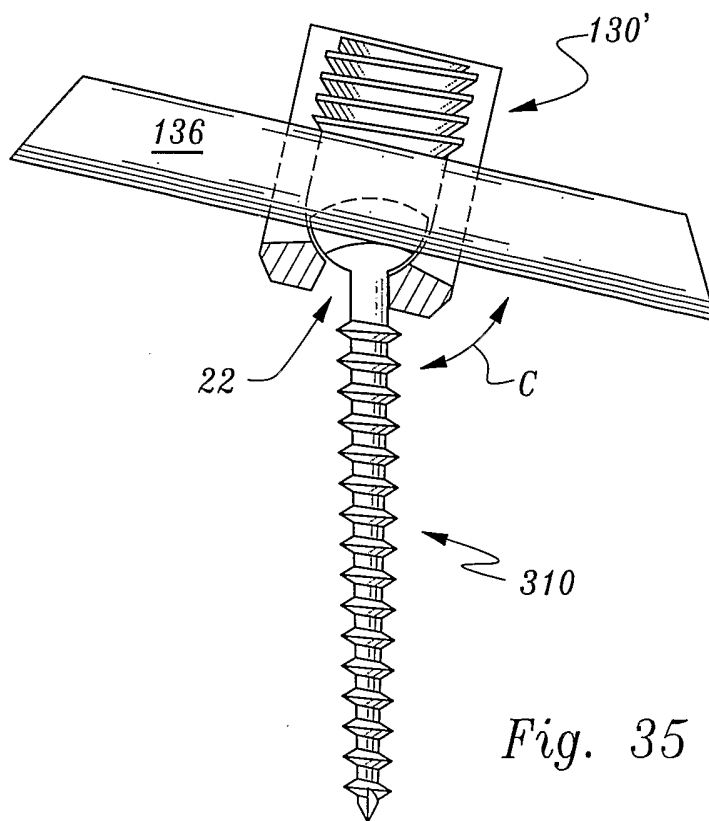

Fig. 35

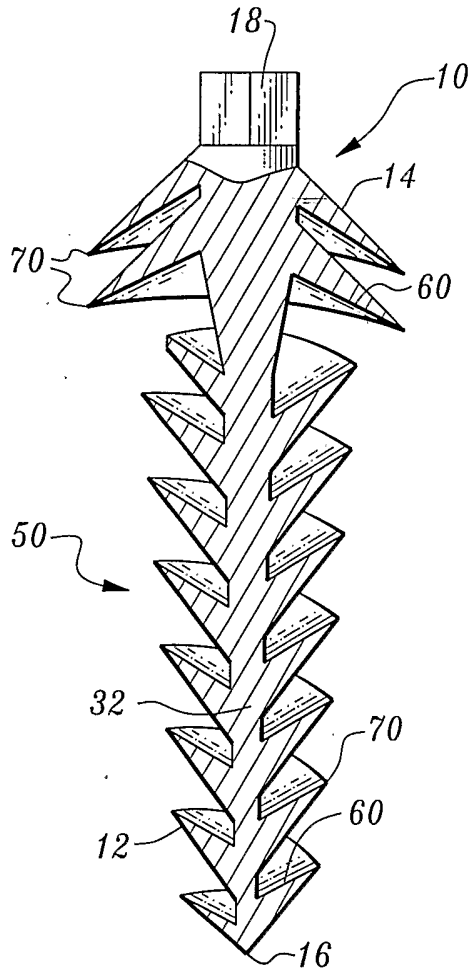

Fig. 36

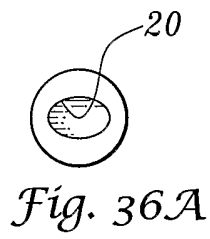

Fig. 36A

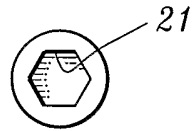

Fig. 36B

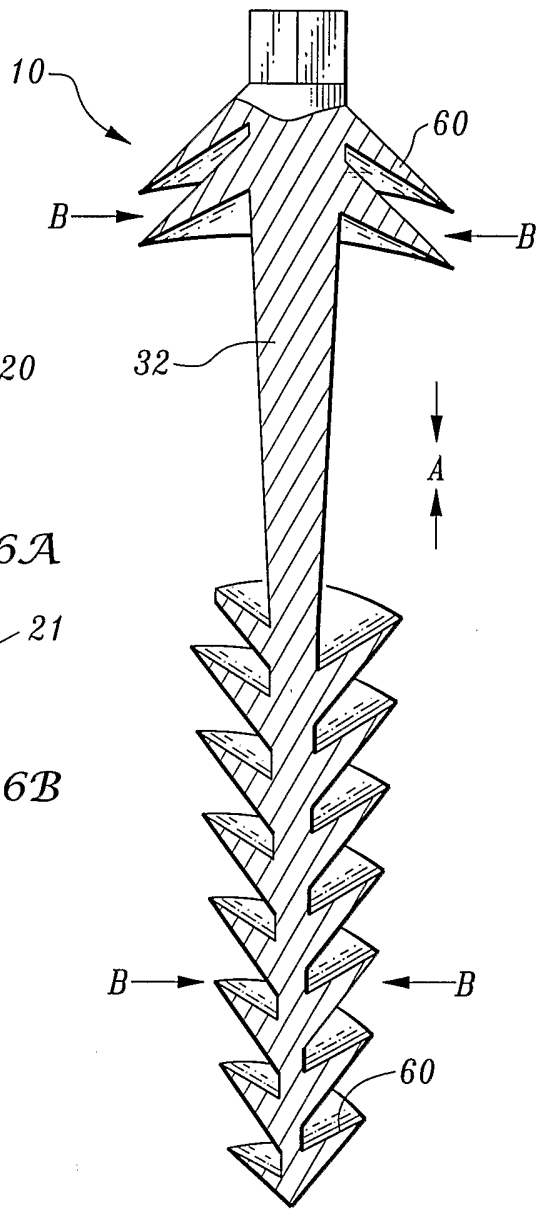
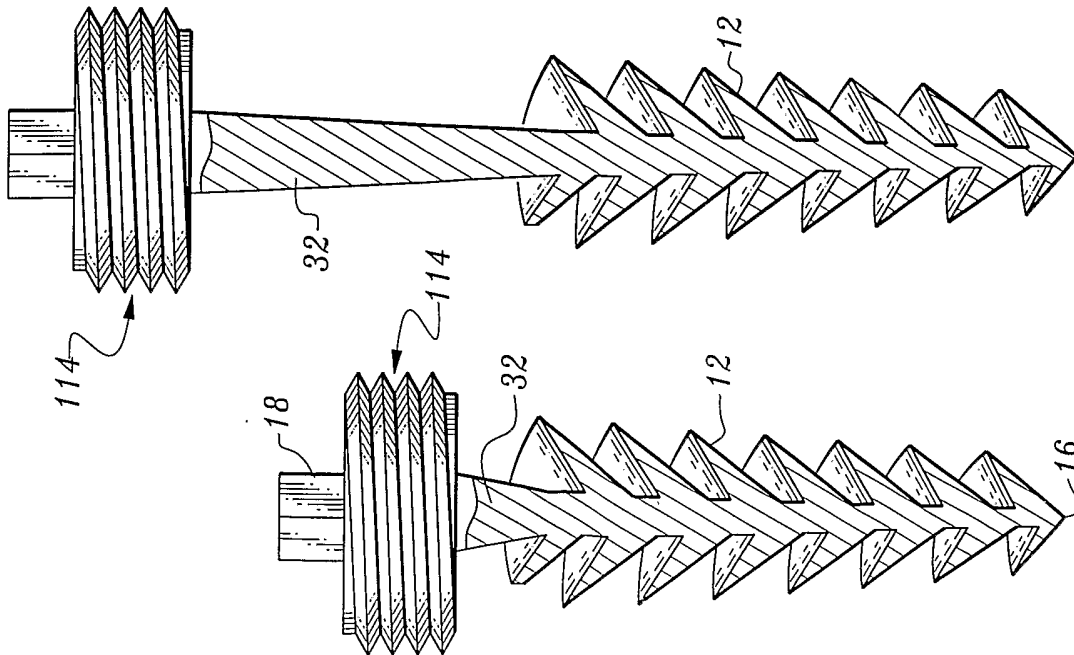
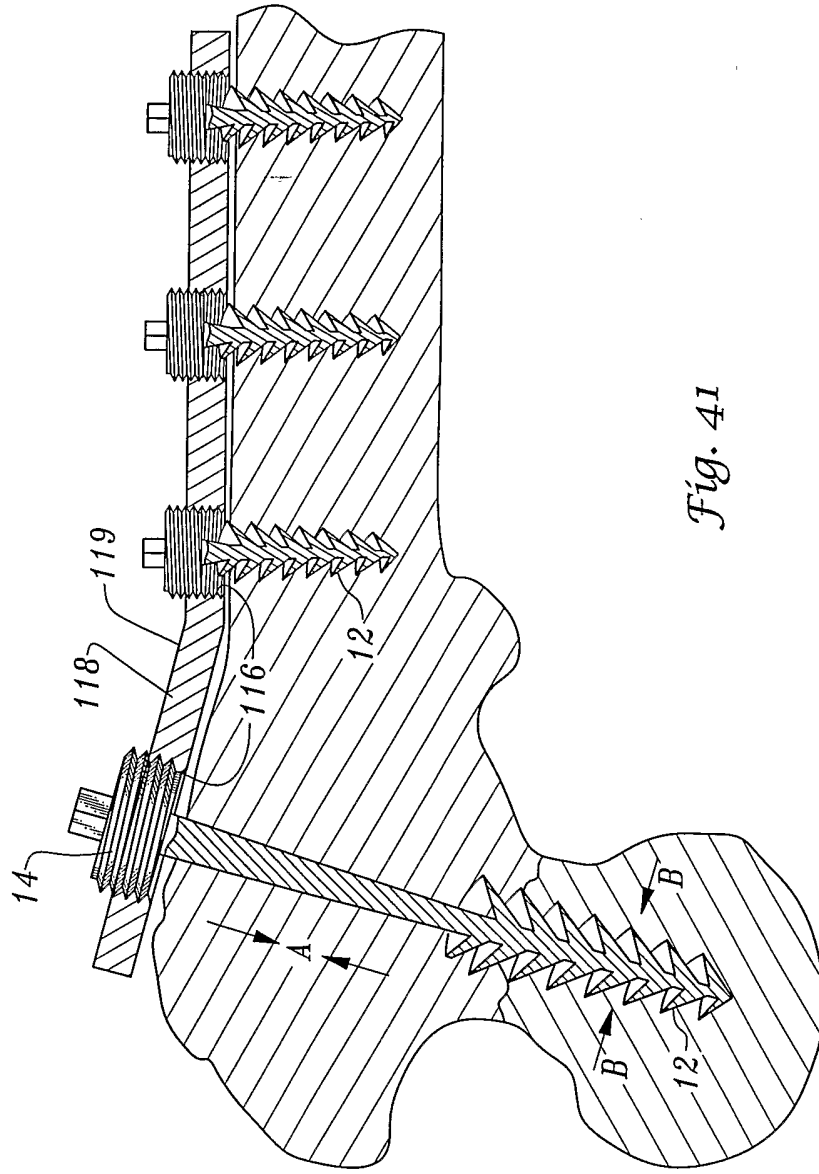

Fig. 37



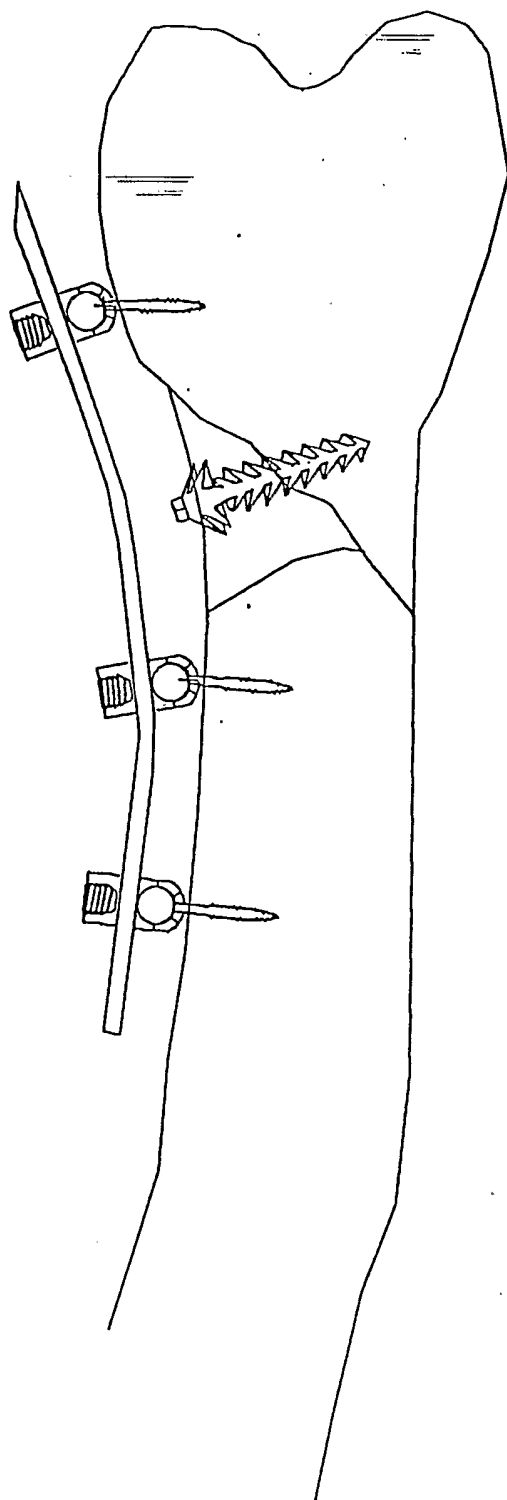
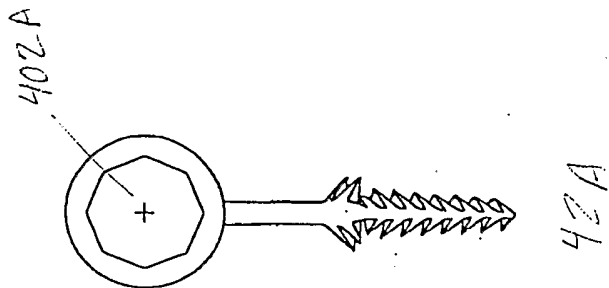
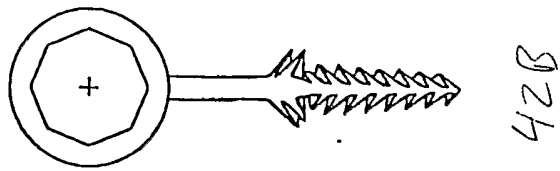
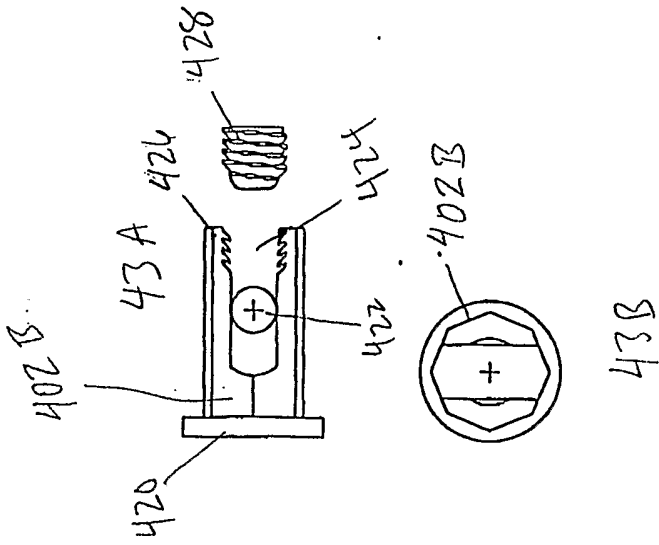
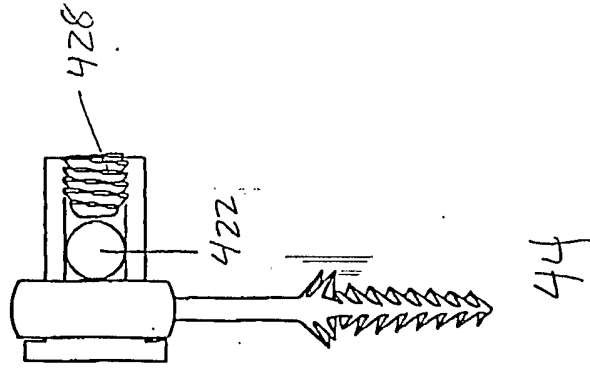
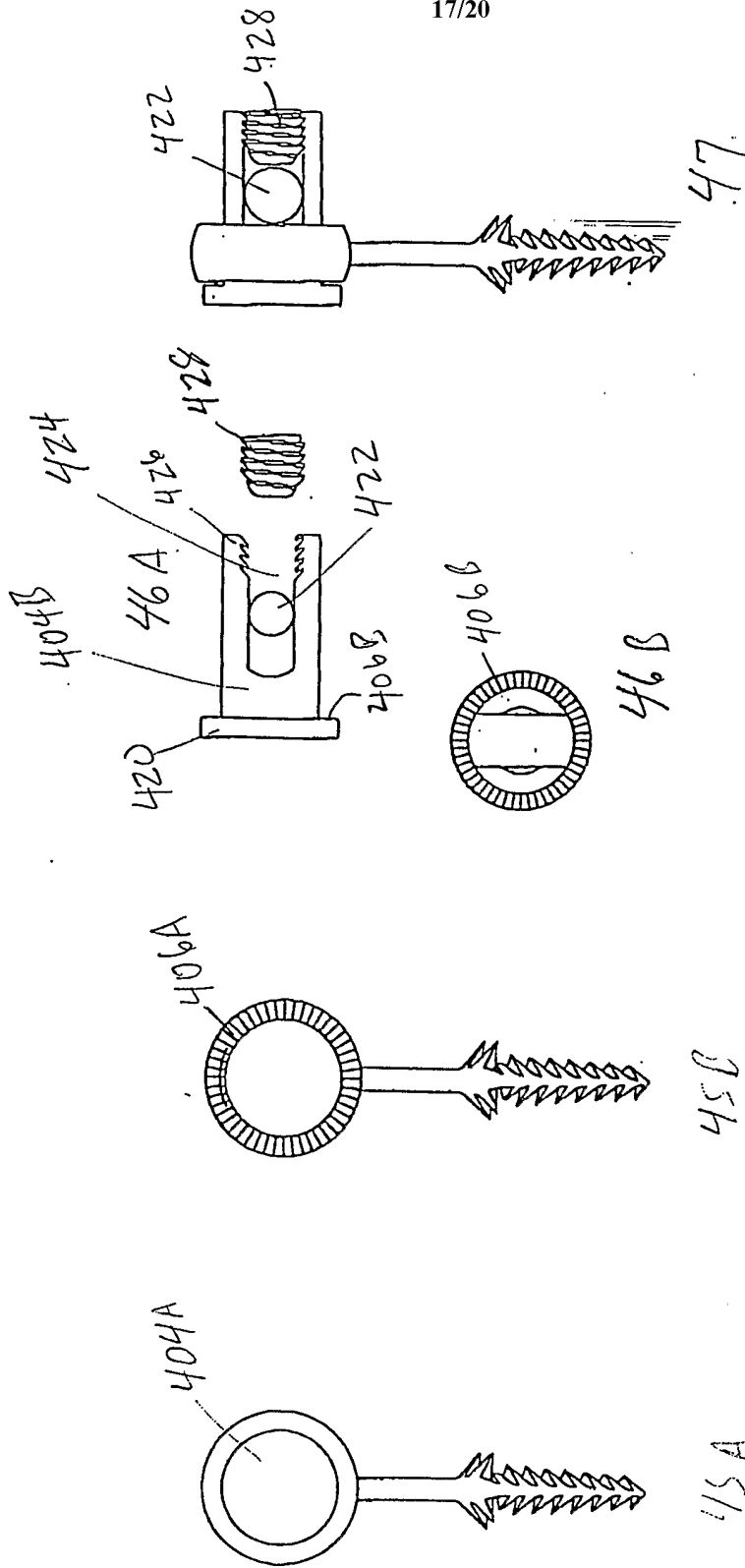
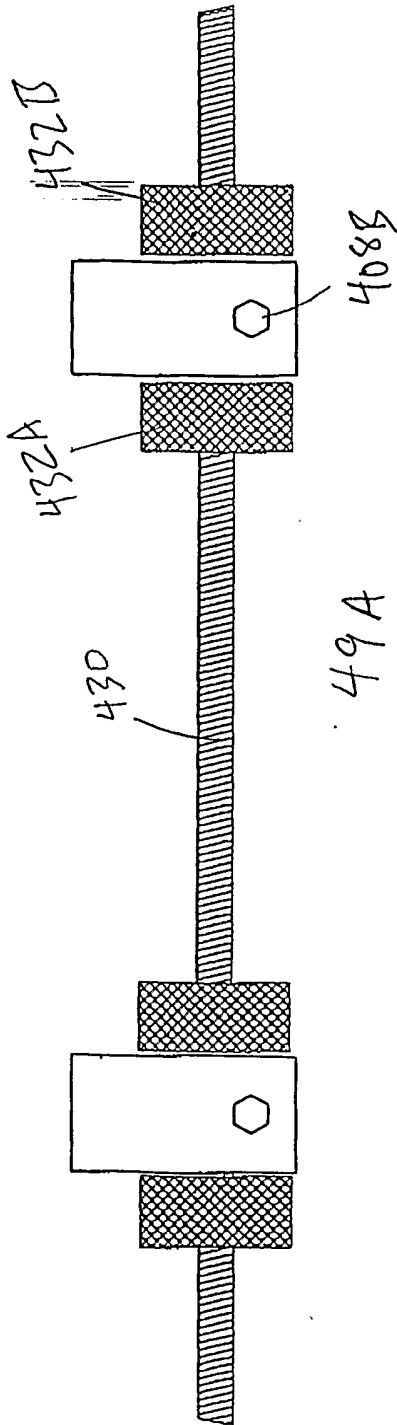

FIG. 38









49A

Threaded square rod

Threaded Rod

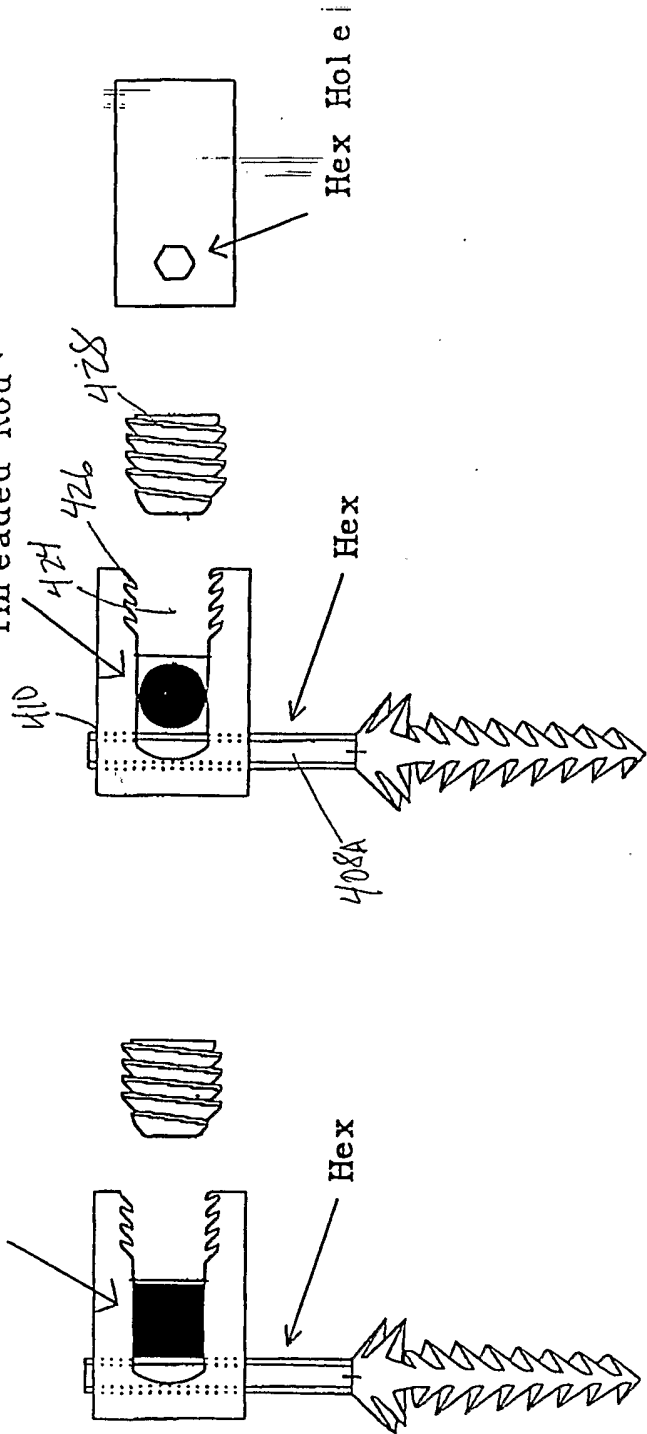

48

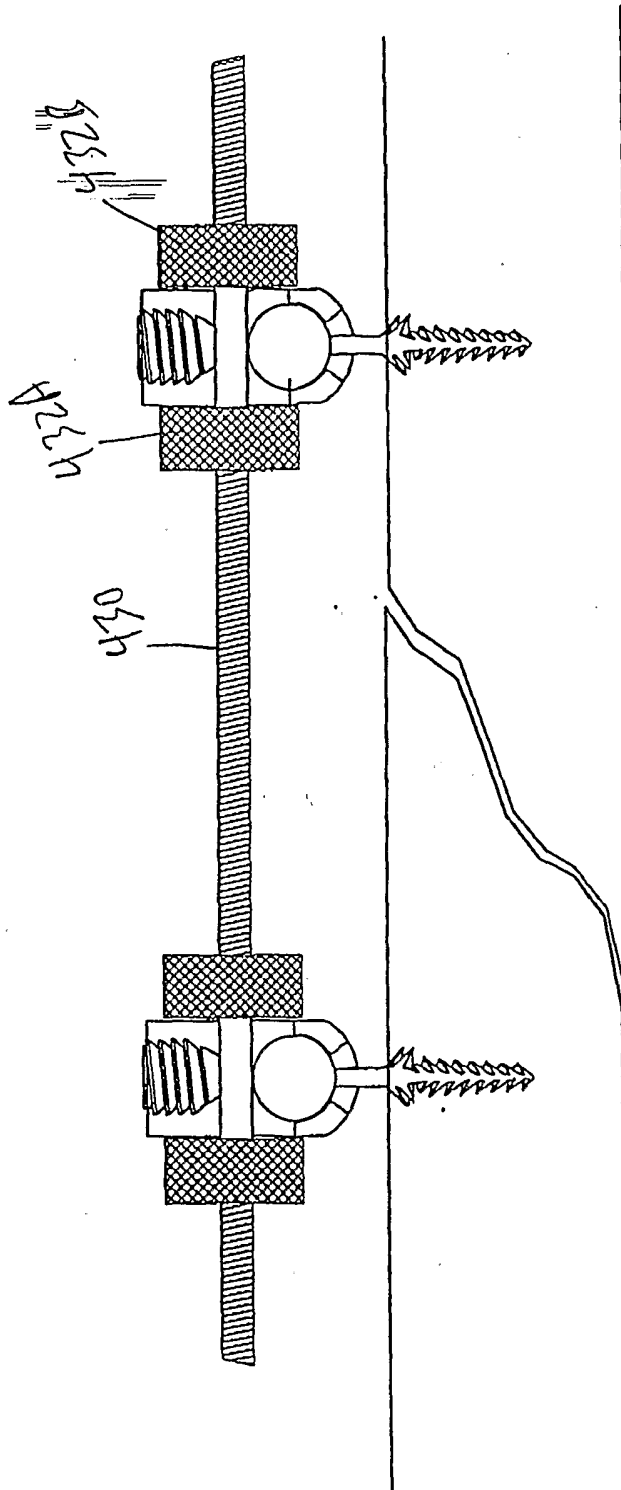

49B

