

Dec. 6, 1938.

H. G. BOLKCOM  
FLOW POINT ATTACHMENT

2,139,486

Filed Dec. 31, 1936

*Fig. 1*

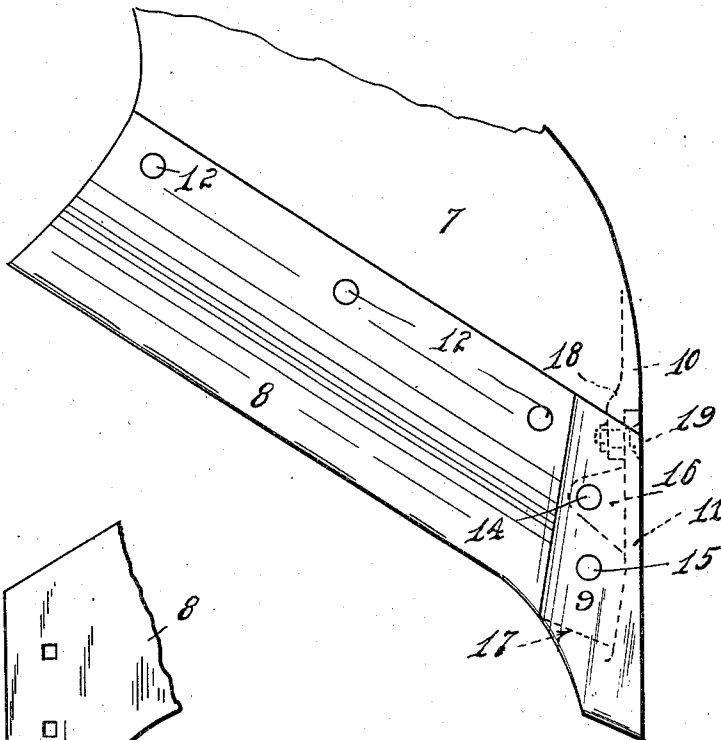

*Fig. 3*

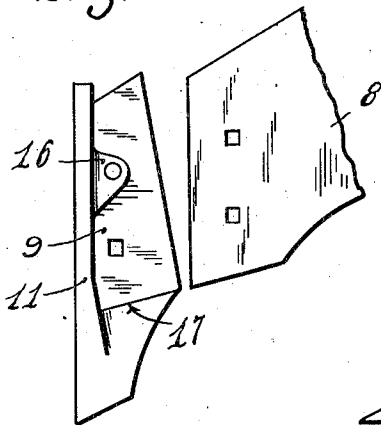

*Fig. 2*

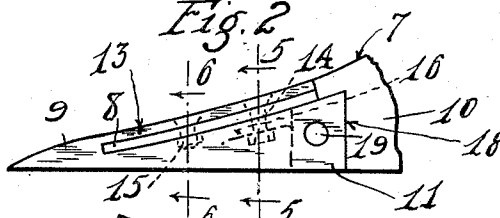

*Fig. 4*



*Fig. 5*

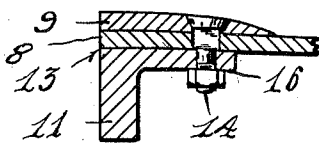

*Fig. 6*

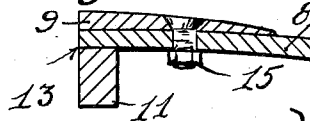

INVENTOR  
Harry G. Bolkcom  
By His Attorneys  
Merchant & Kilgore

# UNITED STATES PATENT OFFICE

2,139,486

## PLOW POINT ATTACHMENT

Harry G. Bolkcom, Minneapolis, Minn.

Application December 31, 1936, Serial No. 118,519

8 Claims. (Cl. 97—125)

My present invention relates to plows and has for its object the provision of a plow point that may be separably and detachably connected to a plow, whereby the point may be readily removed for the purpose of sharpening or repairing the same. In case the point is beyond repair, the same may be quickly removed and a new point substituted therefor. When the improved point is removed from the plow, the share may also be removed from the mold board, to which it is detachably connected, and said share sharpened and repaired. It is obvious that when the point and the share are removed from the plow and separated, the one from the other, the handling thereof, while sharpening or repairing either thereof, is much easier than when they are on the plow.

It is now necessary, when a plow point is worn out, to cut the same from the plow and weld a new one in place thereof. This process requires the selection of a metal that can be readily welded, instead of a metal that has the proper wearing qualities. By making the point separable from the plow, which eliminates the welding process, the share and point may be made of metal selected for their wearing qualities.

To the above end, generally stated, the invention consists of the novel devices and combinations of devices hereinafter described and defined in the claims.

In the accompanying drawing, which illustrates the invention, like characters indicate like parts throughout the several views.

Referring to the drawing:

Fig. 1 is a fragmentary plan view of a plow having the invention embodied therein;

Fig. 2 is a view of the land side of the plow shown in Fig. 1;

Fig. 3 is a fragmentary bottom plan view, showing the point and the share separated, the one from the other;

Fig. 4 is an inside elevation of the point removed from the plow; and

Figs. 5 and 6 are fragmentary detail views in section taken on the lines 5—5 and 6—6, respectively, on Fig. 2, on an enlarged scale.

Of the parts of the plow shown, the numerals 7, 8 and 9 indicate, respectively, the mold board, the share and the point, the latter of which is the subject matter of this invention. The land side of the mold board 7 and the land side of the point 9 are indicated by the numerals 10 and 11, respectively. The share 8 is detachably and removably secured to the mold board 7 by bolts or rivets 12. Formed in the land side 11 of the

point 9 is a slot-like seat 13 in which the respective end of the share is mounted, as best shown in Figs. 5 and 6.

The point 9 overlaps the respective end portion of the share 8, and said point is transversely beveled so that its free longitudinal edge is sharp and closely engages the upper face of the share 8 to afford a relatively smooth surface between said point and share. The point 9 is detachably secured to the share 8 by two nut-equipped bolts 14 and 15, the former of which extends through aligned holes in the point 9, the share 8 and a lug 16 integral with the land side of the point 9. By reference to Figs. 4 and 5 it will be noted that the upper face of the lug 16 is flush with the lower surface of the seat 13, so that the share 8 rests directly thereon.

The bolt 15 extends through aligned holes in the point 9 and the share 8. The uppermost end of the seat 13 is open, see Figs. 2 and 4, so that the share 8 may be freely inserted into said seat, but when the bolts 14 and 15 are tightened, the share 8 is sprung toward the land side 11, thereby frictionally clamping the share 8 between the point 9 and the land side 11. To assist the bolts 14 and 15 in holding the point 9 against angular movement to the share 8 in the plane thereof, there is formed on the under side of the point 9 a transverse shoulder 17 with which the lower longitudinal edge of the share engages throughout the width of the point 9, see Figs. 3 and 4.

To further detachably secure the point 9 to the plow, the forward end portion of the land side 10 is inwardly offset at 18 and overlaps the rear end portion of the land side 11, see Fig. 1, and the overlapped portions of said land sides are detachably connected by a nut-equipped bolt 19.

From the above description, it is evident that the point 9 may be removed from the plow simply by taking out the bolts 14, 15 and 19. In case the share 8 needs to be sharpened or repaired, the same may be removed by taking out the fastening devices 12.

What I claim is:

1. A plow having a removable point, said point and the share having overlapping engagement, the one with the other, said point having a lug on its under side which projects under the share, a fastening device extending through aligned holes in the point, the share and the lug, a second fastening device extending through aligned holes in the point and the share, and a third fastening device releasably connecting the land side of the point to the land side of the mold board.

2. A plow having a removable point, said point

and the share having overlapping engagement, the one with the other, said point having in its land side a slot-like seat in which the respective end portion of the share is mounted, said point  
 5 having on its under side a stop shoulder with which the share engages at its lower longitudinal edge, said point having a lug on its under side which projects under the share, and a fastening device extending through aligned holes in the  
 10 point, the share and the lug.

3. A plow having a removable point, said point and the share having overlapping engagement, the one with the other, said point having in its  
 15 land side a slot-like seat in which the respective end portion of the share is mounted, said point also having on its under side a stop shoulder with which the share engages at its lower longitudinal edge, said point having a lug on its  
 20 under side which projects under the share, a fastening device extending through aligned holes in the point, the share and the lug, a second fastening device extending through aligned holes in the  
 25 point and the share, and a third fastening device detachably connecting the land side of the point to the land side of the mold board.

4. The structure defined in claim 2 in which the slot-like seat is open at its uppermost end, whereby the share may be frictionally clamped

between the point and its land side by said fastening device.

5. A plow having a removable point, said point having in its land side a long slot in which the  
 5 respective end of the share is removably fitted with said point overlapping the share from its land side edge, said point having on its land side a lug underlapping the share, and a fastening device extending through said lug and detachably connecting the overlapping portions of the  
 10 share and point.

6. The structure defined in claim 5 in which the land side of the mold board and the point have vertical overlapping engagement, and a  
 15 second fastening device detachably connecting said mold board and point at the overlapping land side portions thereof.

7. The structure defined in claim 5 in which the point has on its under side a stop shoulder with which the front edge portion of the share  
 20 abuts and is held thereby against relative angular movement.

8. A removable point for a plow having in its land side a long slot of substantially a constant  
 25 width for receiving substantially the entire land side end of a plow share, and means whereby the point may be detachably secured to a plow.

HARRY G. BOLKCOM.