



(51) International Patent Classification:

G01N 27/06 (2006.01) B81B 5/00 (2006.01)
G01N 33/48 (2006.01) B81B 1/00 (2006.01)

(21) International Application Number:

PCT/US2015/013636

(22) International Filing Date:

30 January 2015 (30.01.2015)

(25) Filing Language:

English

(26) Publication Language:

English

(71) Applicant: **HEWLETT-PACKARD DEVELOPMENT COMPANY, L.P.** [US/US]; 11445 Compaq Center Drive W., Houston, Texas 77070 (US).

(72) Inventors: **SELLS, Jeremy**; 1070 NE Circle Blvd., Corvallis, Oregon 97330-4239 (US). **MCGUINNESS, Nicholas Matthew Cooper**; 16399 W Bernardo Dr., San Diego, California 92127-1899 (US). **DOMINGUE, Chantelle Elizabeth**; 1070 NE Circle Blvd., Corvallis, Oregon 97330-4239 (US). **GIRI, Manish**; 1070 NE Circle Blvd., Corvallis, Oregon 97330-4239 (US).

(74) Agents: **KHAN, Saif M.** et al.; Hewlett-Packard Company, Intellectual Property Administration, 3404 E. Hammoy Road, Mail Stop 35, Fort Collins, Colorado 80528-9599 (US).

(81) Designated States (unless otherwise indicated, for every kind of national protection available): AE, AG, AL, AM,

AO, AT, AU, AZ, BA, BB, BG, BH, BN, BR, BW, BY, BZ, CA, CH, CL, CN, CO, CR, CU, CZ, DE, DK, DM, DO, DZ, EC, EE, EG, ES, FI, GB, GD, GE, GH, GM, GT, HN, HR, HU, ID, IL, IN, IR, IS, JP, KE, KG, KN, KP, KR, KZ, LA, LC, LK, LR, LS, LU, LY, MA, MD, ME, MG, MK, MN, MW, MX, MY, MZ, NA, NG, NI, NO, NZ, OM, PA, PE, PG, PH, PL, PT, QA, RO, RS, RU, RW, SA, SC, SD, SE, SG, SK, SL, SM, ST, SV, SY, TH, TJ, TM, TN, TR, TT, TZ, UA, UG, US, UZ, VC, VN, ZA, ZM, ZW.

(84) Designated States (unless otherwise indicated, for every kind of regional protection available): ARIPO (BW, GH, GM, KE, LR, LS, MW, MZ, NA, RW, SD, SL, ST, SZ, TZ, UG, ZM, ZW), Eurasian (AM, AZ, BY, KG, KZ, RU, TJ, TM), European (AL, AT, BE, BG, CH, CY, CZ, DE, DK, EE, ES, FI, FR, GB, GR, HR, HU, IE, IS, IT, LT, LU, LV, MC, MK, MT, NL, NO, PL, PT, RO, RS, SE, SI, SK, SM, TR), OAPI (BF, BJ, CF, CG, CI, CM, GA, GN, GQ, GW, KM, ML, MR, NE, SN, TD, TG).

Declarations under Rule 4.17:

- as to the identity of the inventor (Rule 4.17(i))
- as to applicant's entitlement to apply for and be granted a patent (Rule 4.17(ii))

Published:

- with international search report (Art. 21(3))

(54) Title: MICROFLUIDIC SENSING

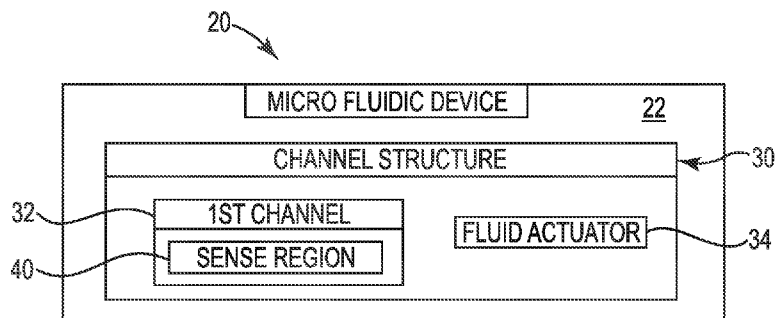

FIG. 1

(57) Abstract: A device including a microfluidic channel structure formed on a substrate and including a first channel and a fluid actuator within the microfluidic channel structure. A sense region within the first channel is to receive a fluid flow of target biologic particles for counting in a single file pattern, with the sense region having a volume on a same order of magnitude as a volume of a single one of the target biologic particles.

WO 2016/122552 A1

MICROFLUIDIC SENSING

Background

[0001] Microfluidics applies across a variety of disciplines and involves the study of small volumes of fluid and how to manipulate, control and use such small volumes of fluid in various systems and devices, such as microfluidic chips. For example, in some instances a microfluidic chip may be used as a "lab-on-chip", such as for use in the medical and biological fields to evaluate fluids and their components.

Brief Description of the Drawings

[0002] FIG. 1 is block diagram schematically illustrating a microfluidic device, according to an example of the present disclosure.

[0003] FIG. 2 is a block diagram schematically illustrating a relationship between a sense region volume and biologic particle volume, according to an example of the present disclosure.

[0004] FIG. 3 is a block diagram schematically illustrating a cassette housing a microfluidic device, according to an example of the present disclosure.

[0005] FIG. 4 is a block diagram schematically illustrating a microfluidic device, according to an example of the present disclosure.

[0006] FIG. 5 is a block diagram schematically illustrating components of a microfluidic device, according to an example of the present disclosure.

[0007] FIG. 6 is a block diagram schematically illustrating a component of a microfluidic device, according to an example of the present disclosure.

[0008] FIG. 7 is a block diagram schematically illustrating a microfluidic test system, according to an example of the present disclosure.

[0009] FIG. 8 is a block diagram schematically illustrating a host device of the system of FIG. 7, according to an example of the present disclosure.

[0010] FIG. 9 is a block diagram schematically illustrating a control interface of the system of FIG. 7, according to an example of the present disclosure.

[0011] FIG. 10 is a plan view schematically illustrating a portion of a microfluidic device including a channel structure and associated components, according to an example of the present disclosure.

[0012] FIG. 11 is an enlarged partial plan view schematically illustrating a sensing portion within a microfluidic channel structure, according to an example of the present disclosure.

[0013] FIG. 12 is a diagram schematically illustrating a sense region volume and a biologic particle volume, according to an example of the present disclosure.

[0014] FIG. 13 is an enlarged partial plan view schematically illustrating a sensing portion within a microfluidic channel structure, according to an example of the present disclosure.

[0015] FIG. 14 is a sectional view taken along lines 14—14 of FIG. 13 to schematically illustrate a constriction associated with a sense region, according to an example of the present disclosure.

[0016] FIG. 15 is an enlarged partial plan view schematically illustrating a sense region within a microfluidic channel structure, according to an example of the present disclosure.

[0017] FIG. 16 is a diagram including a side plan view schematically illustrating a series of sensing portions within a microfluidic channel structure, according to an example of the present disclosure.

[0018] FIG. 17 is a side plan view schematically illustrating several sensing portions arranged in parallel within a microfluidic channel structure, according to an example of the present disclosure.

Detailed Description

[0019] In the following detailed description, reference is made to the accompanying drawings which form a part hereof, and in which is shown by way of illustration specific examples in which the disclosure may be practiced. It is to be understood that other examples may be utilized and structural or logical

changes may be made without departing from the scope of the present disclosure. The following detailed description, therefore, is not to be taken in a limiting sense.

[0020] At least some examples of the present disclosure are directed to microfluidic devices to evaluate biologic fluids. In some examples, such microfluidic devices may be employed in cytology, such as cell counting and analysis. For instance, one common medical procedure includes evaluating a blood sample to determine a white blood cell count or a red blood cell count, which may be indicative of a particular medical condition, health of an organ, etc.

[0021] At least some examples of the present disclosure provide for high throughput and increased accuracy in cytology on a microfluidic chip via high signal-to-noise ratios achievable by employment of single file sensing and a low fluid dilution factor, among other features and attributes. In some examples, this arrangement is at least partially enabled via providing a sense region within a channel structure of the microfluidic chip, in which the sense region has a volume (e.g. a sense volume) of the same order of magnitude as a volume of the biologic particle of interest.

[0022] By causing the biologic particles of interest to pass through the sensing region in a single file pattern, the arrangement provides for sensing or counting biologic particles on a one-at-a-time basis.

[0023] In some examples, this arrangement is at least partially enabled via providing a non-uniform flow field within the channel structure prior to and/or within the sense region. In some examples, the non-uniform flow field is at least partially enabled via an exclusion structure located upstream from the sense region to exclude biologic particles larger than the target biologic particle of interest. In some examples, the non-uniform flow field is at least partially enabled via a reduction in the cross-sectional area of the channel structure just prior to the sense region.

[0024] Moreover, when the above-described features are combined with other operational aspects of the microfluidic device, in some examples, a throughput rate of sensing (e.g. counting) up to 1 million biologic particles per second are

achievable. In some examples, such operational aspects of the microfluidic device include the use of on-board pumps, on-board heaters, on-board mixing, and/or on-board sensors, all present on a small footprint substrate.

[0025] Rapid counting via these high throughput rates, in turn, significantly reduces a total time of testing involving a particular biologic particle to thereby make point-of-care diagnostic testing practical for real world, clinical settings and while doing so with relatively low cost test chips.

[0026] Cytology procedures utilizing at least some examples of the present disclosure are not restricted to blood, but extend to other biologic fluids or biologic fluid preparations to detect bacteria and/or viruses in saliva, urine, spinal fluid, etc. Other applicable examples include counting yeast cells in a brewery environment, or obtaining sperm cell counts or egg counts. As further described below, at least some examples of the present disclosure achieve high accuracy and throughput for these many different types and sizes of biologic particles via providing sensing structures sized and/or shaped to enhance sensing (e.g. counting) the particular biologic particle of interest.

[0027] These examples, and additional examples, are described and illustrated in association with at least FIGS. 1-17.

[0028] FIG. 1 is a block diagram schematically illustrating a microfluidic device 20, according to an example of the present disclosure. As shown in FIG. 1, the microfluidic device 20 is formed on a substrate 22, and includes a channel structure 30, which in turn includes a first channel 32 and a fluid actuator 34 to cause movement of fluid through at least the first channel 32. The first channel 32 includes a sense region 40 to facilitate sensing a biologic particle of interest, i.e. a target biologic particle.

[0029] In some examples, the target biologic particle forms part of a biologic fluid, such as whole or partial blood. Some example biologic particles include red blood cells, white blood cells, viruses, etc. found within whole or partial blood. In some examples, the biologic particle forms part of other natural biologic fluids or other biologic fluid preparations, as noted above.

[0030] In some instances, the microfluidic device 20 is referred to as a microfluidic chip or a biologic test chip.

[0031] As further illustrated in FIG. 2, in some examples the sense region has a volume 50 that is commensurate with a volume 52 of the target biologic particle within the fluid flowing in the first channel 32. In particular, in some examples, the sense region volume 50 is on the same order of magnitude as the biologic particle volume 52. In some instances, the sense region volume 50 is referred to herein as the sense volume.

[0032] The dimensions and volumes of some examples of different types of biologic particles are further described later.

[0033] FIG. 3 is a block diagram schematically illustrating a module 60 including a microfluidic device 20 (FIGS. 1-2), according to an example of the present disclosure. In some instances, the module is referred to as a cassette or container. As shown in FIG. 3, module 60 includes a housing 61 that at least partially contains and/or supports the microfluidic device 20.

[0034] In some examples, as shown in FIG. 3 fluid reservoir 64 is defined within housing 61 in close proximity to microfluidic device 20 to enable fluid communication therebetween. As shown via FIG. 3, the fluid sample 67 is deposited (via inlet 62) to enter fluid reservoir 64 and mix with reagent(s) 66 before flowing into microfluidic device 20. In some instances, microfluidic device 20 includes its own reservoir to initially receive the fluid sample (mixed with reagents 66) from reservoir 64 before the fluid flows into channels of the microfluidic device 20.

[0035] If the fluid sample 67 is blood, then in some examples the reagent(s) 66 includes an anti-coagulant, such as ethylenediamine tetraacetic acid (EDTA), and/or buffer solution such as phosphate buffered saline (PBS). In some examples, a suitable blood sample has volume of about 2 microliters while the reagent has a volume of about 8 microliters, leading to a volume of 10 microliters to be processed via the microfluidic device 20. Accordingly, in this arrangement, a dilution factor of about 5 is applied to the fluid sample of whole blood. In some examples, dilution factors of more than or less than 5 are applied to whole blood. In some examples, such low dilution factors ensure a high signal-to-noise ratio when a sense volume of the fluid (to be tested) passed through the sensing region at which target biological particles are counted. In

addition, lower dilution factors involve a smaller total volume of fluid to be processed by the microfluidic device, which in turn reduces the total test time for the particular fluid sample. In some examples, a dilution factor that is equal to or less than ten is employed.

[0036] In some examples, whether the fluid sample 67 is blood or another type of biological fluid, volumes greater or less than 2 microliters can be used. In addition, in some examples, whether the fluid sample 67 is blood or another type of biologic fluid, reagent volumes greater or less than 8 microliters can be used. In some examples, a fluid sample 67 is also diluted with other or additional fluids other than reagents 66.

[0037] In some examples, the dilution factor for blood or any fluid sample 67 can be implemented according to the order of tens, which includes dilution factors such as 10, 20, 30, 40, 50, 60, 70, 80, and 90, as well as quantities intervening between these stated values.

[0038] It will be understood that in some examples, the dilution factor (applied to fluid sample 67) can be implemented according to the order of ones, which includes dilution factors of one, two, three, four, five, six, seven, eight, and nine.

[0039] It will be further understood that when whole blood is the fluid sample 67, in some examples the reagent(s) 66 include other or additional reagents to prepare the blood for a diagnostic test of interest. In some examples, such reagent(s) 66 help sensors identify certain particles in the fluid sample in order to track them, count them, move them, etc. In some examples, such reagent(s) 66 bind with certain particles in the fluid sample 67 in order to facilitate excluding or filtering those certain particles from the fluid to better isolate or concentrate a particular biologic particle of interest. In some examples, the operation of the reagent(s) 66 works in cooperation with filters and/or other sorting and segregation mechanisms to exclude certain biologic particles from a sensing region of the microfluidic device 20.

[0040] In some examples, reagent(s) 66 include materials suitable to perform antibody-antigen binding for micro-particle tagging and/or materials suitable to implement nano-particle tagging techniques, magnetic particle sorting techniques, and/or high density particle tagging techniques.

[0041] In some examples, at least some reagent(s) 66 include lysing agents, such as (but not limited to) when it is desired to separate out red blood cells prior to implementing subsequent counting or analysis of white blood cells.

[0042] Of course, in the event that the fluid sample 67 is not blood but is a different biologic fluid, such as urine, spinal fluid, etc., then reagent(s) 66 would include an appropriate type and number of reagent(s) 66 suited to handling such fluids and to achieve the desired separation and sorting of the components of those fluids.

[0043] FIG. 4 is a block diagram schematically illustrating a microfluidic device 80, according to an example of the present disclosure. In some examples, microfluidic device 80 includes at least some of substantially the same features and attributes as microfluidic device 20 of FIGS. 1-3. In some examples, at least some components of microfluidic device 80 of FIG. 3 are incorporated within the microfluidic device 20 of FIGS. 1-3.

[0044] As shown in FIG. 3, microfluidic device 80 includes actuator(s) 82 and attribute sensor(s) 84, with actuators 82 functioning as a pump 85A and/or as a heater 85B. In some examples, actuator 82 comprises a resistive element, such as a thermal resistor. When activated at a high intensity, and sufficient pulse width, the actuator 82 may nucleate a vapor bubble that displaces fluid within the channel structure 30 to drive fluid along and through the channel structure 30. As a byproduct, a moderate amount of heat may be produced. In one aspect, such high intensity activation involves a relatively short pulse width, and higher power.

[0045] However, when activated at a low intensity and insufficient pulse width, the actuator 82 does not act as a pump because insufficient energy is present to cause a nucleation event, and thus significant fluid displacement. Instead, heat may be produced, such that actuator 82 functions as a heater 85B without displacing fluid. In one aspect, such low intensity activation involves a relatively longer pulse width, and lower power.

[0046] In some examples, microfluidic device 80 includes an attribute sensor(s) 84 to detect an attribute of the fluid or constituents of the fluid. In some examples, the attribute sensor 84 comprises an impedance sensor to count

biologic particles flowing through channel structure 30, as further described below in association with at least FIGS. 10-17.

[0047] A later described control interface 106 is couplable to an electrical interface of the microfluidic device for energizing and controlling operations of the actuator(s) 82 and sensor(s) 84. In some examples, the structures and components of the chip-based microfluidic device 20, 80 are fabricated using integrated circuit microfabrication techniques such as electroforming, laser ablation, anisotropic etching, sputtering, dry and wet etching, photolithography, casting, molding, stamping, machining, spin coating, laminating, and so on.

[0048] FIG. 5 is a block diagram schematically illustrating components 86, 87 of a microfluidic device, according to an example of the present disclosure. In some examples, a microfluidic device such as device 20, 80 (FIGS. 1-4) further includes inlet/outlet chambers 86 and/or filters 87. The inlet/outlet chambers enable fluid to enter and exit various portions of the channel structure 30 while filters 87 segregate different components of a fluid from each other, such as excluding larger particles from further passage through the channel structure 30, as further noted later. In some instances, such filters 87 are referred to as an exclusion structure.

[0049] FIG. 6 is a block diagram schematically illustrating a thermal sensor 88 of a microfluidic device, according to an example of the present disclosure. In some examples, a microfluidic device such as device 20, 80 (FIGS. 1-4) further includes a thermal sensor(s) 88. In some examples, thermal sensor 88 tracks a temperature of at least the channel structure 30 and the fluid therein to facilitate managing reaction processes associated with implementing a test of interest on a given biologic fluid present within the channel structure 30. In one example, the thermal sensor(s) 88 is a resistive element that changes resistance as a function of the temperature of the resistive element.

[0050] FIG. 7 is a block diagram schematically illustrating a microfluidic test system, according to an example of the present disclosure. As shown in FIG. 7, system 100 includes a cassette 60, a control interface 106 (with housing 107), and a host device 108. In some examples, cassette 60 includes at least some of substantially the same features and attributes as cassette 60, as

previously described in association with at least FIG. 3, and with microfluidic device 20 including at least some of substantially the same features and attributes as microfluidic device 20, 80, as previously described in association with at least FIGS. 1-6.

[0051] As shown in FIG. 7, in addition to at least microfluidic device 20, cassette 60 includes an input/output (I/O) module 102 to communicate power, data, and/or control signals, etc. between the microfluidic device 20 (within cassette 60) and the control interface 106, which is in turn in communication with the host device 108.

[0052] In some examples, as shown in FIG. 7, cassette 60 is removably couplable to the control interface 106 so that it can be coupled and uncoupled as desired. The control interface 106 is removably couplable to the host device 108 as further described below. In some instances, the control interface 106 is referred to as or embodied as a dongle or connector.

[0053] In general terms, a fluid sample 67 (FIG. 3) is processed through microfluidics and applied to a sensing region in the microfluidic device 20 under control of the control interface 106. The microfluidic device 20 provides an electrical output signal representing the sensor data (e.g. a count of biologic particles) to the control interface 20. With the control interface 20 under control of the host device 108, the host device 108 can send and receive data to and from the control interface 106, including command information for controlling the microfluidic device 20 and obtaining sensor data obtained from the microfluidic device 20.

[0054] FIG. 8 is a block diagram schematically illustrating the host device 108 (FIG. 7), according to an example of the present disclosure. As shown in FIG. 8, in some examples, the host device 108 generally includes a central processing unit (CPU) 110, various support circuits 112, memory 114, various input/output (IO) circuits 116, and an external interface 118. The CPU 110 includes a microprocessor. In some examples, the support circuits 112 include a cache, power supplies, clock circuits, data registers, and the like. In some examples, the memory 114 includes random access memory, read only memory, cache memory, magnetic read/write memory, or the like or any combination of such

memory devices. In some examples, the IO circuits 116 cooperate with the external interface 118 to facilitate communication with the control interface 106 over a communication medium 119 (shown in FIG. 7). The communication medium 119 can involve any type of wired and/or wireless communication protocol and can include electrical, optical, radio frequency (RF), or the like transfer paths.

[0055] In some examples, the external interface 118 includes a universal serial bus (USB) controller to send and receive data to the control interface 106, as well as providing power to the control interface 106, over a USB cable. It is to be understood that in some examples, other types of electrical, optical, or RF interfaces to the control interface 106 are used to send and receive data and/or provide power.

[0056] In some examples, as shown in FIG. 8, the memory 114 of host device 108 stores an operating system (OS) 109 and a driver 111. The OS 109 and the driver 111 include instructions executable by the CPU 110 for controlling the host device 108 and for controlling the control interface 106 through the external interface 118. The driver 111 provides an interface between the OS 109 and the control interface 106. In some examples, the host device 108 comprises a programmable device that includes machine-readable instructions stored on non-transitory processor/computer readable-media (e.g., the memory 114).

[0057] In some examples, as shown in FIG. 8, the host device 108 includes a display 120 through which the OS 109 can provide a graphical user interface (GUI) 122. A user can use the user interface 122 to interact with the OS 109 and the driver 111 to control the control interface 106, and to display data received from the control interface 106. It will be understood that the host device 108 can be any type of general or specific-purposed computing device. In an example, the host device 108 is a mobile computing device, such as a "smart phone," "tablet" or the like.

[0058] FIG. 9 is a block diagram schematically illustrating the control interface 106, according to an example of the present disclosure. In one example, the control interface 106 includes a controller 134, IO circuits 136, and a memory 138. The controller 134 comprises a microcontroller or microprocessor. In some

examples, control interface 106 receives power from the host device 108, while in some examples, the control interface 106 includes a power supply 142.

[0059] In some examples, memory 138 stores instructions 140 executable by the controller 134 for at least partially controlling the microfluidic device 20 and/or for communicating with the host device 108. As such, the control interface 106 comprises a programmable device that includes machine-readable instructions 140 stored on non-transitory processor/computer readable-media (e.g., the memory 138). In other examples, the control interface 106 may be implemented using hardware, a combination of hardware and instructions 140 stored in memory 138. For instance, in some examples all or a portion of the control interface 106 is implemented using a programmable logic device (PLD), application specific integrated circuit (ASIC), or the like.

[0060] FIG. 10 is a diagram schematically illustrating a microfluidic structure 200 of a portion of a microfluidic device 20, according to an example of the present disclosure. In some examples, the microfluidic structure 200 includes at least some of substantially the same features and attributes as microfluidic device 20, 80 as previously described in association with at least FIGS. 1-9.

[0061] As shown in FIG. 10, in some examples the microfluidic structure 200 includes a microfluidic channel 202, a fluid actuator 204, a sensor 206, a nozzle 205 (e.g., outlet), and an inlet 208. FIG. 10 also depicts a fluid reservoir 214, which is in communication with the fluid reservoir 64 of cassette 60 (FIG. 3). In some examples, a mesh filter 212 is provided in the fluid reservoir 214 for filtering particles in the applied fluid sample. While the shape of the fluid channel 202 in FIG. 10 is shown as being "U-shaped", this is not intended as a general limitation on the shape of the channel 202. Thus, the shape of the channel 202 can include other shapes, such as curved shapes, serpentine shapes, shapes with corners, combinations thereof, and so on. Moreover, the channel 202 is not shown to any particular scale or proportion. The width of the channel 202 as fabricated on a device can vary from any scale or proportion shown in the drawings of this disclosure. The arrows in the channel indicate an example direction of fluid flow through the channel.

[0062] The inlet 208 provides an opening for the channel 202 to receive the fluid. In some examples, the filter 210 is disposed in the inlet 208 and prevents particles in the fluid of a particular size (depending on the size of the filter 210) from entering the channel 202. In some examples, the inlet 208 can have a larger width and volume than the channel 202. For instance, the inlet 208 can define a progressively narrowing cross-sectional area in the downstream orientation. In one aspect, as further described below, these structures help to create a non-uniform flow field, which facilitates single file flow of biologic particles into channel 202.

[0063] However, it will be understood that in some examples, such filters 210 are not located in inlet 208, but are located upstream from inlet 208 and external to channel 202. In some examples, a filter is located in the cassette 60 upstream from the reservoir 214. As noted elsewhere, in some instances such a filter is referred to as an exclusion structure. In some examples, the sensor 206 is disposed in the channel 202 near the inlet 208 (e.g., closer to the inlet 208 than the pump actuator 204) as shown in FIG. 10. In some examples, the sensor 206 is disposed in the inlet 208. In some examples, the sensor 206 is an impedance sensor and detects impedance changes as biologic particles in the fluid pass over the sensor 206. In some examples, the sensor 206 produces a signal whose intensity is directly proportional to the size of the biologic particle passing over/through the sensor 206, and thereby provides a basis to count biologic particles.

[0064] Further details regarding such structures are described below in association with at least FIGS. 11-16.

[0065] As further shown in FIG. 10, in some examples the fluid actuator 204 (e.g. pump) is disposed near a closed end of the channel 202 downstream from the sensor 206. The fluid actuator 204 can be a fluidic inertial pump actuator, which can be implemented using a wide variety of structures. In some examples, the fluid actuator 204 is a thermal resistor that produces vapor bubbles to create fluid displacement within the channel 202. The displaced fluid is ejected from the nozzle 405, thereby enabling an inertial flow pattern within/through channel 202. In some examples, fluid actuator 204 is

implemented as piezo elements (e.g., PZT) whose electrically induced deflections generate fluid displacements within the channel 202. Other deflective membrane elements activated by electrical, magnetic, and other forces are also possible for use in implementing the fluid actuator 204.

[0066] In some examples, the fluid actuator 204 causes fluid displacements of less than ten picoliters and can be fired at a frequency ranging from 1 Hz to 100 kHz.

[0067] In general terms, the fluid actuator 204 is positioned in sufficiently close proximity to sensor 20 to ensure high fluid flow rates and therefore high particle count rates, such as up to 1 Million per second. Although not shown, in some examples, fluid actuator 204 is positioned to cause inertial pumping that pushes biologic particles through the region at sensor 206 while in some examples, fluid actuator 204 is positioned to cause inertial pumping that pulls biologic particles through the region at sensor 206, as shown in FIG. 10.

[0068] FIG. 11 is an enlarged partial side view schematically illustrating a sensing portion 221 of a microfluidic channel structure, according to an example of the present disclosure. In some examples, the sensing portion 221 forms part of a microfluidic device having at least some of substantially the same features and attributes as microfluidic device 20, 80 as previously described in association with at least FIGS. 1-10. As shown in FIG. 11, sensing portion 221 includes inlet 208 in communication with channel 202. In some examples, inlet 208 has a cone-shape that begins (at A) with a diameter substantially larger than a width (W1) of the channel 202 and then decreases to an end point (at B) at a junction 230 with the channel 202 to match the width of the channel 202. Among other features, the cone-shaped inlet 208 contributes to forming a non-uniform flow field to facilitate aligning biologic particles into a single file for one-at-a-time movement through the channel 202 at attribute sensor(s) 220. While omitted for illustrative clarity, in some examples a filter 210 is provided within inlet 208 to exclude biologic particles having a size larger than a size of the biologic particles of interest, i.e. target biologic particles to be counted. In some examples, such filter 210 comprises pillars spaced apart by a distance that enables fluid flow and passage of the target biologic particles but which

prevents passage of the larger biologic particles. This filter 210 further contributes to the non-uniform flow field which aligns the target biologic particles for single file entry and passage through channel 202 at the attribute sensor(s) 220. As previously mentioned, this filter 210 is sometimes referred to as an exclusion structure.

[0069] In some examples, the sensor 220 includes resistive elements that act as an impedance sensor to detect attributes of target biologic particles. For example, one attribute detected via the sensor 220 includes counting the biologic particles as they pass one-at-a-time through the sense region of channel 202.

[0070] In some examples, channel 202 is formed with a cross-sectional area to define a sense volume 240 of fluid (including a single target biologic particle) that moves through the channel 202 and over sensor 220. As shown at least partially in FIG. 11, the sense volume 240 has a width (W_1), a length (L_1), and a height (H_1), which is further depicted in FIG. 12. The sense volume 240, depicted in FIGS. 11-12 is not a physical structure but rather a representation of a volume of fluid that moves through the channel 202 over/through sensor 220 and which is just large enough to carry a single biologic particle 260. While FIG. 12 depicts a red blood cell (RBC), it will be understood that biologic particle 260 is not limited to biologic particles of the blood but can be any biologic particle of a biologic fluid (biologic fluid preparation) or other food-related biologic particle, such as yeast cells.

[0071] It will be understood that the sense volume 240 is not necessarily a cube but can form other shapes that generally correspond to a cross-sectional shape of the channel 202 through which the fluid moves in the region of sensor 220. For example, if the channel 202 in that region has a generally circular cross-sectional shape, the sense volume takes on a generally disc shape, cylindrical shape, or spherical shape. Accordingly, a sense volume represents a volume of fluid in which a particular biologic particle resides as the target biologic particle moves through channel 202 in region of sensor 220 at a time at which the biologic particle is being sensed for counting.

[0072] It will be further understood that any given type of target biologic particle will have its own unique geometry, and that the target biologic particles described herein are not limited to the shape and size of the biologic particle illustrated in FIG. 12. Accordingly, a volume of the target biologic particle will not necessarily have a uniform shape, topology, etc. Nevertheless, as one example, FIG. 12 depicts a red blood cell having diameter (D1) and a thickness (T1) and a generally disc-shaped appearance. Moreover, in some examples, for purposes of counting cells via sensor 220 and for aligning biologic particles into a single file in channel 202 at the region of sensor 220, the overall volume of the biologic particle 260 can be less significant than the value of the greatest dimension (e.g. height, width, length, diameter, etc.) of the biologic particle which may be the factor by which the biologic particles become sorted and aligned into a single file. Accordingly, depending on the target biologic particle of interest, the size/shape of the channel 202 is selected to form a sense volume of fluid that by definition will carry just one biologic particle.

[0073] In some examples, the sense volume has the same order of magnitude as a volume of the target biologic particle carried within the sense volume. Stated differently, a volume of a sense region has the same order of magnitude as a volume of the target biologic particle carried within the volume of fluid moving through or over sensor 220 at the time of sensing.

[0074] This arrangement enables a high signal-to-noise ratio (SNR) at the location of the sensor 220 to yield a highly efficient and effective counting mechanism. In particular, because a small volume of fluid is present in the vicinity of the sensor 220 for each biologic particle being counted, a relatively stronger signal is registered for each biologic particle that is present at a particular instance of sensing (i.e. at a particular snapshot or window of the sensing data signal).

[0075] In some examples, a volume fraction is defined by a ratio of the volume of a single biologic particle relative to the sense volume. In some examples, the volume fraction is on an order of tenths, such as 0.1 (i.e. 10%). For instance, if the fluid sample is whole blood and the target biologic particle is red blood cells, then the largest dimension (in this instance, a diameter) of the target biologic

particle is about 6 micrometers, and a volume of on the order of 0.1 picoLiters (e.g. 9×10^{-17} Liters in some instances). Assuming the first sense channel provides for a cross-sectional area of about 100 micrometers, and a length of 10 micrometers, then the first channel is sized to define a sense volume of about 1 picoLiters. In this scenario, the volume fraction would be about 0.1, as mentioned above. It will be understood that this example is not strictly limiting, as depending on the particular biologic particle and the particular size and shape of the channel at the sense region, in some examples the sense volume can range from 1 to 10 times the volume of the biologic particle.

[0076] Given that commercially available cytometers greatly dilute the fluid (e.g. up to 100 to 1000 times) in which the biologic particles reside in order to sufficiently separate the biologic particles to enable counting via the techniques available to them, they provide volume fractions such as 0.001 (0.1%), which is about two orders of magnitude greater than the volume fraction achieved via at least some examples of the present disclosure.

[0077] However, examples of the present disclosure are not strictly limited to operating according to volume fractions of 0.1, but rather can operate according to different volume fractions (e.g. 0.25, 0.4, 0.5, 0.6, 1.1, 1.5 etc.) depending on the particular type of biologic particle, which has its own unique shape and size.

[0078] In some examples, the size and shape of the channel in the sensing region account for behavioral characteristics of the particular biologic particle of interest. For example, red blood cells are readily conformable, and therefore the size and shape of the channel at the sensing region to receive red blood cells can be made to closely match the size of the red blood cells because it can be expected that the red blood cells will bend, compress, or conform enough to enable their entry into the sensing region. Conversely, other particles that have odd dimensions (elongate, triangular, etc.) or that are relatively less conformable may involve providing a size and shape of the sensing region of the channel that is more forgiving in view of the particular characteristics of that biologic particle of interest.

[0079] In some examples, a microfluidic device is employed to count biologic particles other than blood cells. For example, some viruses or bacteria present

within a fluid sample can be counted. Some viruses have a diameter on the order of 50-300 nanometers, while some bacteria have dimensions on the order of 3 x 0.6 micrometers. In some examples, sperm or eggs are counted with sperm having dimensions on the order of 5 micrometers and eggs having dimensions on the order of 130 micrometers. Some types of these biologic particles (e.g. some viruses) can be an order of magnitude or two orders of magnitude smaller than other biologic particles, such as red blood cells. Accordingly, in some of these examples, additional structures are employed within channel 202 to provide the desired sense volume, such as later further described in association with at least FIGS. 13-15.

[0080] It will be further understood that due to the significance resulting from how the shape and size of the channel 202 (at least in the region of sensor 220) is defined to correspond generally to the size and shape of the target biologic particle, in some examples a different microfluidic device or chip is provided to test each different target biologic particle. In some examples, a single microfluidic device counts different target biologic particles but does so by providing different channels 202 to do so, with each different channel being dedicated to testing for a particular target biologic particle while excluding differently sized/types of other biologic particles. In some examples, as further described later in association with at least FIG. 16, a single microfluidic device includes a series of channel portions, with each channel portion sized and shaped to provide a sense volume (at the region of sensor 220) corresponding to a target biologic particle such that the series of channel portions provide single file (one-at-a-time) counting of different target biologic particles in a sequence. In some examples, as further described later in association with at least FIG. 17, a single microfluidic device provides parallel channels in which each channel detects a different type/size of target biologic particles from a single fluid sample with at least some of the different channels utilizing a sense volume different than a sense volume defined by other respective channels.

[0081] FIG. 13 is an enlarged partial side view schematically illustrating a sensing portion 241 of a microfluidic channel structure, according to an example of the present disclosure. In some examples, the sensing portion 241

comprises a sensing portion having at least some of substantially the same features and attributes as sensing portion 221, as previously described in association with at least FIGS. 11-12.

[0082] As shown in FIG. 13, sensing portion 241 defines a channel 202 having a sensor region 243 at which protrusion(s) 242 formed in channel 202 are provided to define a constriction 244 in close proximity to the sensor 220. At that point along channel 202, the constriction 244 defines a width (W_2) that is less than a general width (W_1) of channel 202. In some examples, this arrangement is employed when it is desirable to retain a general width (W_1) of channel 202 yet still provide structures (e.g. constriction 244) to achieve single file alignment and counting of target biologic particles that have a volume (or largest dimension) that is significantly smaller than a cross-sectional area of the channel 202.

[0083] Figure 14 is a sectional view as taken along lines 14—14 of FIG. 13 that schematically illustrates the available slot 248 (having width W_2) through which fluid and particles can flow at the point of constriction 244.

[0084] FIG. 15 is an enlarged partial side view of a constriction 244 in a channel near a sensor region, according to an example of the present disclosure. As shown in FIG. 15, the constriction 244 is formed via two protrusions 242 on opposite side walls of channel 202.

[0085] In some examples, as shown in FIGS. 13, 15, the constriction 244 is located coextensively with at least a portion of sensor 220. In other words, the constriction occupies at least some of generally the same space as a portion of the sensor 220. In the particular non-limiting example shown in FIG. 15, resistive elements 255 of sensor 220 straddle the constriction 244 defined by protrusions 266. In this way, a sense volume 270 is defined in close proximity to sensor 220 such that at the time (or close to) of sensing a target biologic particle 272, the sense volume 270 in which the target biologic particle 272 resides has a volume on the same order of magnitude of the volume of the target biologic particle 272 to thereby ensure that a single target biologic particle 272 passes through the sensor region (e.g. single file) to provide one-at-a-time sensing of biologic particles. In some examples, the constriction 244 is located

just prior to (e.g. upstream) and immediately adjacent to the resistive elements of sensor 220.

[0086] In some examples, as further shown in FIG. 15, channel 202 further defines a filter 280 (including elements 282) just prior to the constriction 244 to further exclude biologic particles (not shown) larger than the target biologic particles 272 for which the constriction 244 is sized and shaped. In addition to providing a size/shape limitation to enable passage of target biologic particles 272 (while excluding other larger particles), the presence of the protrusions 242 in combination with filter 280 produces a non-uniform fluid flow to cause alignment of the target biologic particles 272 into a single file for passage through constriction 244 and through sensor 220.

[0087] FIG. 16 is a side view schematically illustrating a sensing portion 300 of a microfluidic channel structure, according to an example of the present disclosure. In some examples, the sensing portion 300 forms part of a microfluidic device having at least some of substantially the same features and attributes as microfluidic device 20, 80 as previously described in association with at least FIGS. 1-10 and with sensing portion 300 including at least some of substantially the same features and attributes as previously described in association with FIGS. 11-15.

[0088] With reference to at least FIG. 16, it will be understood that the elements of the sensing portion 300 are not necessarily drawn to scale but, at least, provide a demonstration of relative sizes and shapes.

[0089] As shown in FIG. 16, sensing portion 300 includes a series of sensing zones 301A (1st Zone), 301B (2nd Zone), 301C (3rd Zone) shown separated by dashed lines. Each different zone 301A, 301B, 301C is provided to detect or count a different size biologic particle. For example, as depicted in FIG. 16, first zone 301A counts biologic particles having a diameter (or largest dimension) less than a dimension D3, whereas second zone 301B counts biologic particles having a diameter (or largest dimension) less than dimension D4, which is also less than dimension D3. Third zone 301C counts biologic particles having a diameter (or largest dimension) less than dimension D5, which is also less than dimension D4. In each zone, a channel portion 302A, 302B, 302C has a cross-

sectional area sized and shaped to cause single file flow of the target biologic particle for that particular channel portion 302A, 302B, 302C to ensure that counting by sensors involves just the target biologic particle for that particular zone. Accordingly, channel portion 302A has a different cross-sectional area than channel portion 302B, and channel portion 302B has a different cross-sectional area than channel portion 302D, and so on.

[0090] In some examples, each zone 301A, 301B, 301C includes an inlet 308A, 308B, 308C (respectively) and a filter 310A, 310B, 310C (respectively) to create a non-uniform flow field to facilitate the single file flow of target biologic particles for each respective zone. Moreover, in doing so, each respective filter 310A, 310B, 310C excludes biologic particles larger than the target biologic particle for the particular zone.

[0091] Each zone 301A, 301B, 301C includes a sensing region defining a respective sense volume 340A, 340B, 340C (as the biologic particle passes through) that is sized on the same order of magnitude as the particular target biologic particle to be sensed in the corresponding respective zone 301A, 301B, 301C. Zone 301A includes an attribute sensor 322A including elements 323A while zone 301B includes an attribute sensor 322B including elements 323B, and zone 301C includes an attribute sensor 322C including elements 323C.

[0092] While not depicted in FIG. 16 for illustrative simplicity, it will be understood that in some examples, the different zones 301A, 301B, 301C do not immediately follow on another but can have other channel portions or components (e.g. pumps, heaters, other attribute sensors, flow rate sensors, etc.) between adjacent or successive zones 301A, 301B, 301C.

[0093] Moreover, it will be understood that in some examples, multiple different sensing portions can be arranged in series along a single channel as in FIG. 16, but with each sensing portion having substantially the same sized sense volume as the other sensing portions to count/sense one size of a target biologic particle. In some examples, such an arrangement facilitates validating measurement accuracy or by providing internal controls (i.e. integrity factor).

[0094]

FIG. 17 is a diagram schematically illustrating a sensing portion 400 of a microfluidic channel structure, according to an example of the present disclosure. In some examples, the sensing portion 400 has at least some of substantially the same features and attributes as sensing portion 300, except instead of arranging the different zones 301A, 301B, 301C (with each including their respective features and attributes) in series, the sensing portion 400 provides similar zones 401A, 401B, 401C in parallel, each having a corresponding channel portion 402A, 402B, 402C. Accordingly, rather than counting the biologic particles in sequence, the sensing portion 400 does so in parallel. In some examples, the different zones 401A, 401B, 401C have the same size sense volumes to enable calibration or to facilitate faster processing of a given fluid sample.

[0095] In some examples, all three channel portions 402A, 402B, 402C are in fluid communication with a common reservoir, such as reservoir 214 (FIG. 10). However, in some examples, each channel portion 402A, 402B, 402C receives a fluid (including biologic particles to be processed and counted) from independent fluid reservoir portions and not from a single common reservoir. As such, in some examples, each independent reservoir can include a different composition of fluids. In some examples, the independent reservoir is formed via separation barriers formed in reservoir 214.

[0096] At least some examples of the present disclosure provide for high throughput and increased accuracy in cytology with high signal-to-noise ratios achievable via employment of single file sensing and a low fluid dilution factor, among other features and attributes. Accordingly, this arrangement is well suited for deployment in point-of-care (POC) settings to achieve rapid diagnostic and evaluative information.

Although specific examples have been illustrated and described herein, a variety of alternate and/or equivalent implementations may be substituted for the specific examples shown and described without departing from the scope of the present disclosure. This application is intended to cover any adaptations or variations of the specific examples discussed herein.

CLAIMS

1. A biologic test chip comprising:
 - a substrate;
 - a microfluidic channel structure formed on the substrate and including a first channel;
 - a fluid actuator within the microfluidic channel structure.
 - a sense region within the first channel to receive a fluid flow of biologic particles on a one-at-a-time basis via operation of the fluid actuator, the sense region having a volume on a same order of magnitude as a volume of a single respective one of the biologic particles.
2. The chip of claim 1, wherein the sense region operates according to a volume fraction in which a ratio of the volume of each single biologic particle relative to the volume of the sense region is on an order of tenths.
3. The chip of claim 2, comprising:
 - at least one impedance sensor generally coextensive within the sense region to count biologic particles passing through the sense region.
4. The chip of claim 3, wherein the biologic particles are subject to a dilution factor on the order of tens.
5. The chip of claim 4, wherein the channel structure provides a non-uniform flow portion to align the biological particles into a single file flow pattern through the sense region, the non-uniform flow portion including at least one of:
 - an exclusion structure upstream from the sense region to exclude biologic particles larger than the volume of the sense region; and
 - an inlet including a progressively narrowing cross-sectional area in the downstream orientation.

6. The chip of claim 5, wherein the first channel generally defines a first cross-sectional area and the first channel includes a constriction generally coextensive with the sense region in which the constriction has a second cross-sectional area substantially less than the first cross-sectional area.

7. The chip of claim 1, wherein at least some of the biologic particles are blood cells.

8. A biologic test chip comprising:

a substrate;

a microfluidic channel structure formed on the substrate and including:

a first sensing portion including a first channel to receive a fluid including a first size biologic particles, the first channel including a first sense region having a first volume on a same order of magnitude as a volume of a single one of the first size biologic particles to cause single file counting at the first sense region; and

a second sensing portion including a second channel to receive a fluid including a second size biologic particles, the second channel including a second sense region having a second volume on a same order of magnitude than a volume of a single one of the second size biologic particles to cause single file counting at the second sense region.

9. The chip of claim 8, wherein the first and second biologic particles are subject to a dilution factor on the order of tens.

10. The chip of claim 8, wherein each respective first and second channel provides a non-uniform flow portion to align the biological particles into a single file flow pattern through the respective first and second sense regions, the non-uniform flow portion including at least one of:

an exclusion structure upstream from the first and second sense regions to exclude biologic particles larger than the volume of the respective first and second sense regions; and

an inlet including a progressively narrowing cross-sectional area in the downstream orientation.

11. The chip of claim 8, wherein the respective first and second sensing portions are arranged in series, with the second sensing portion located downstream from the first sensing portion.

12. The chip of claim 8, wherein the respective first and second sensing portions are arranged in parallel.

13. A kit comprising:

a plurality of different biologic test chips with each chip corresponding to a differently-sized biologic particle, wherein each chip includes:

a substrate;

a microfluidic channel structure formed on the substrate and including a first channel;

a fluid actuator within the microfluidic channel structure; and

a sense region within the first channel to receive a single file fluid flow of biologic particles via operation of the fluid actuator, the sense region having a volume on a same order of magnitude as a volume of a single respective one of the biologic particles,

wherein the sense volume of the sense region of a respective different chip corresponds a size of the biologic particle for that respective different chip.

14. The kit of claim 13, wherein the sense region includes at least one impedance sensor for counting the biologic particles.

15. The kit of claim 13, wherein the biologic particles are subject to a dilution factor on the order of tens, and wherein the channel structure provides a non-uniform flow portion to align the biological particles into a single file flow pattern through the sense region, the non-uniform flow portion including at least one of:

an exclusion structure upstream from the sense region to exclude biologic particles larger than the volume of the sense region; and

an inlet including a progressively narrowing cross-sectional area in the downstream orientation.

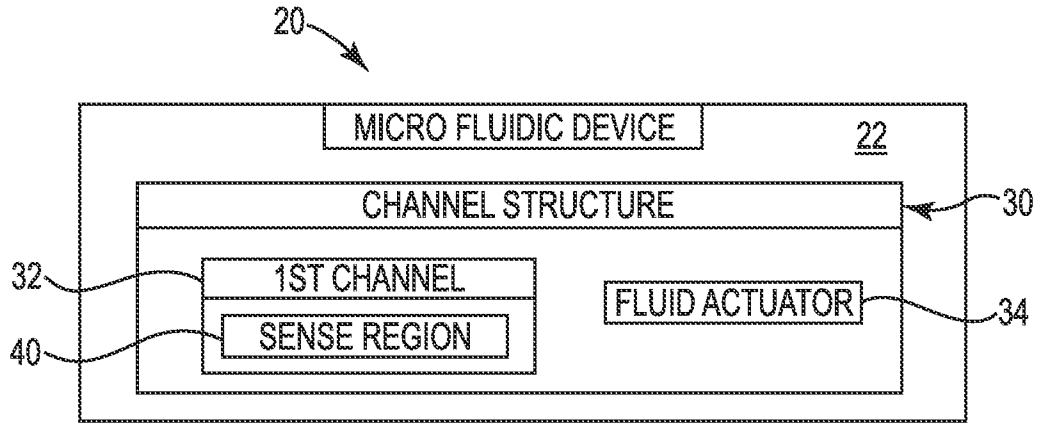

FIG. 1

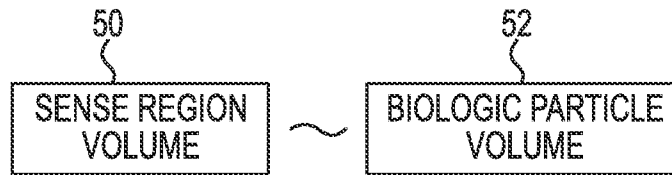

FIG. 2

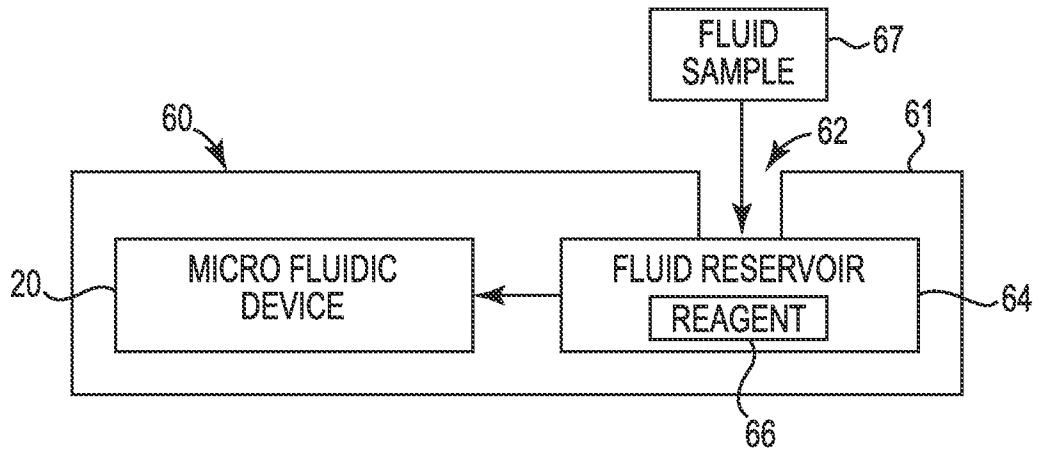

FIG. 3

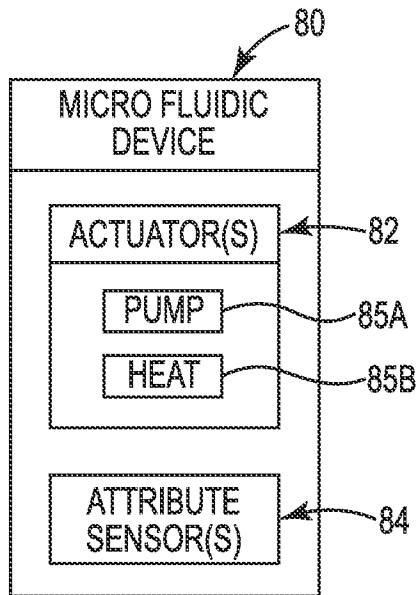

FIG. 4

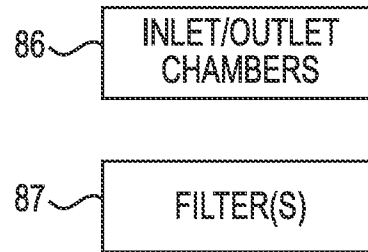

FIG. 5

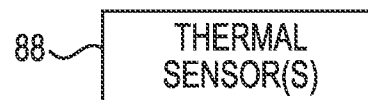

FIG. 6

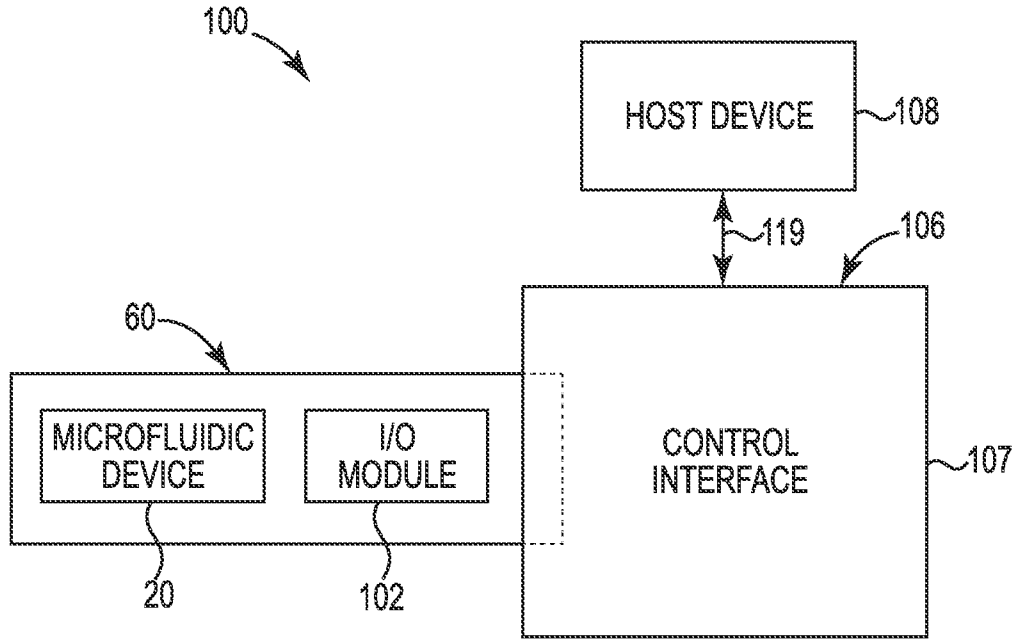

FIG. 7

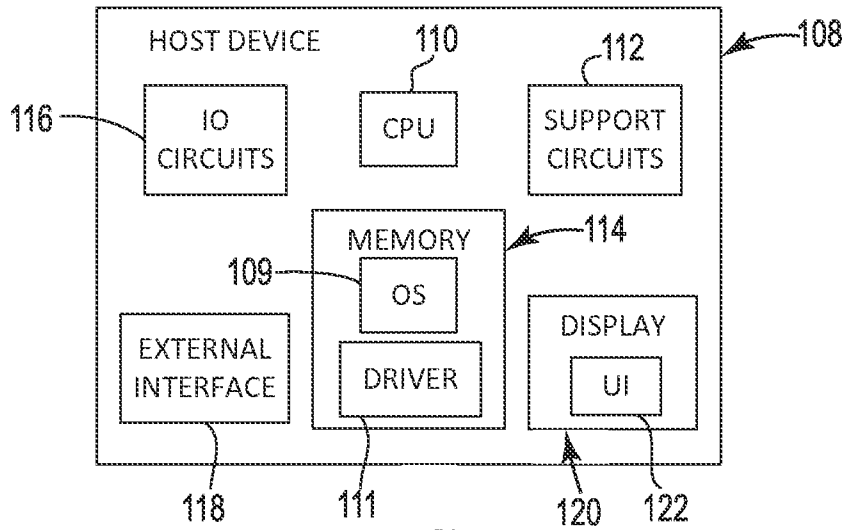

FIG. 8

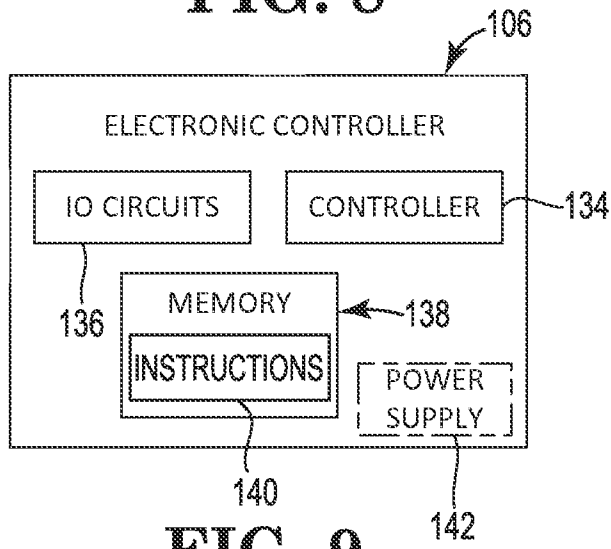

FIG. 9

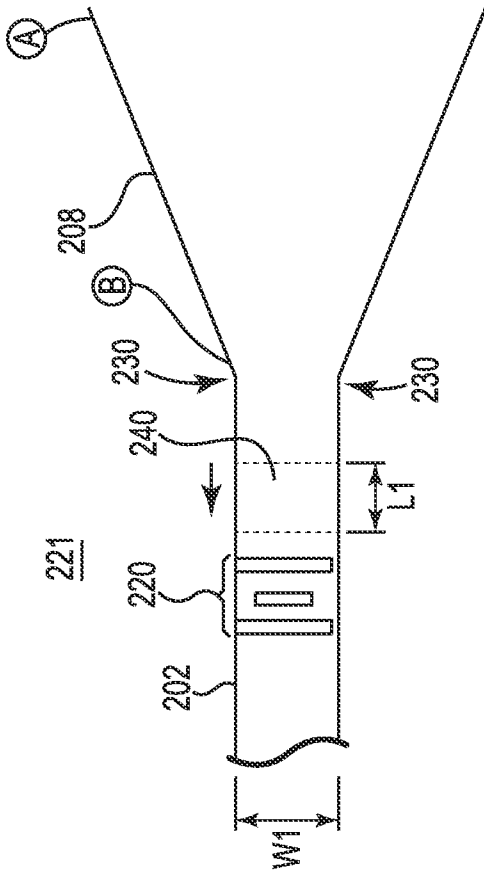

FIG. 11

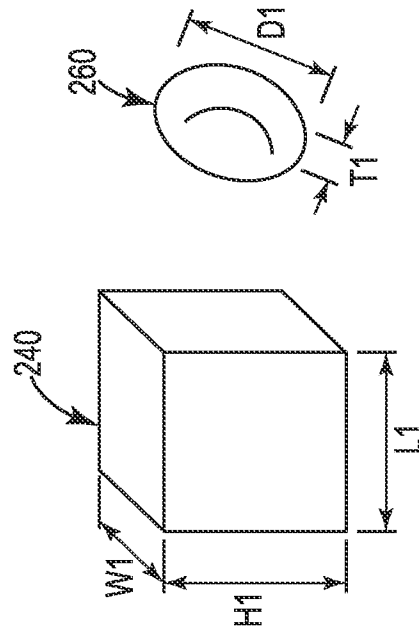

FIG. 12

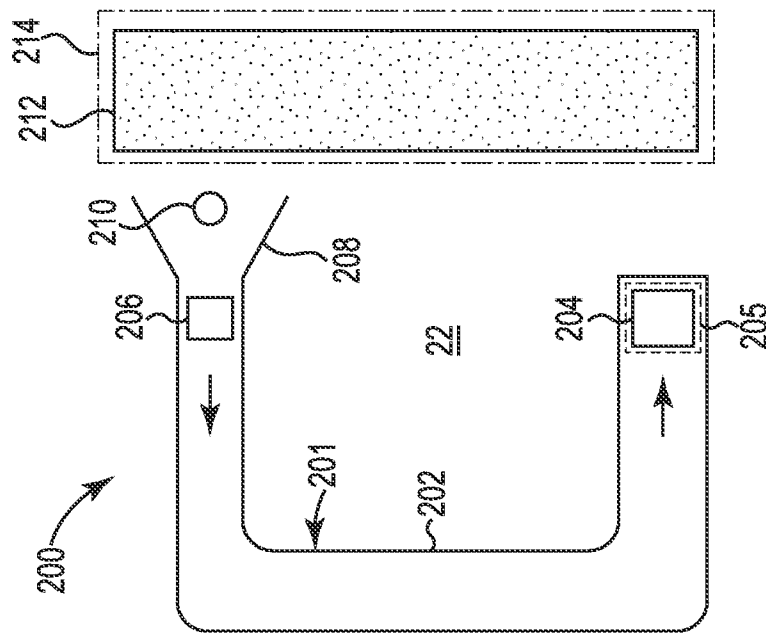

FIG. 10

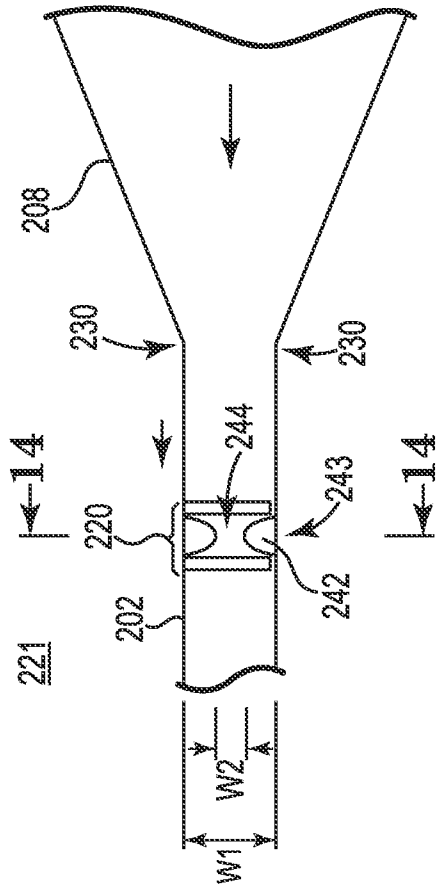

FIG. 13

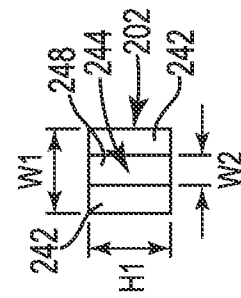

FIG. 14

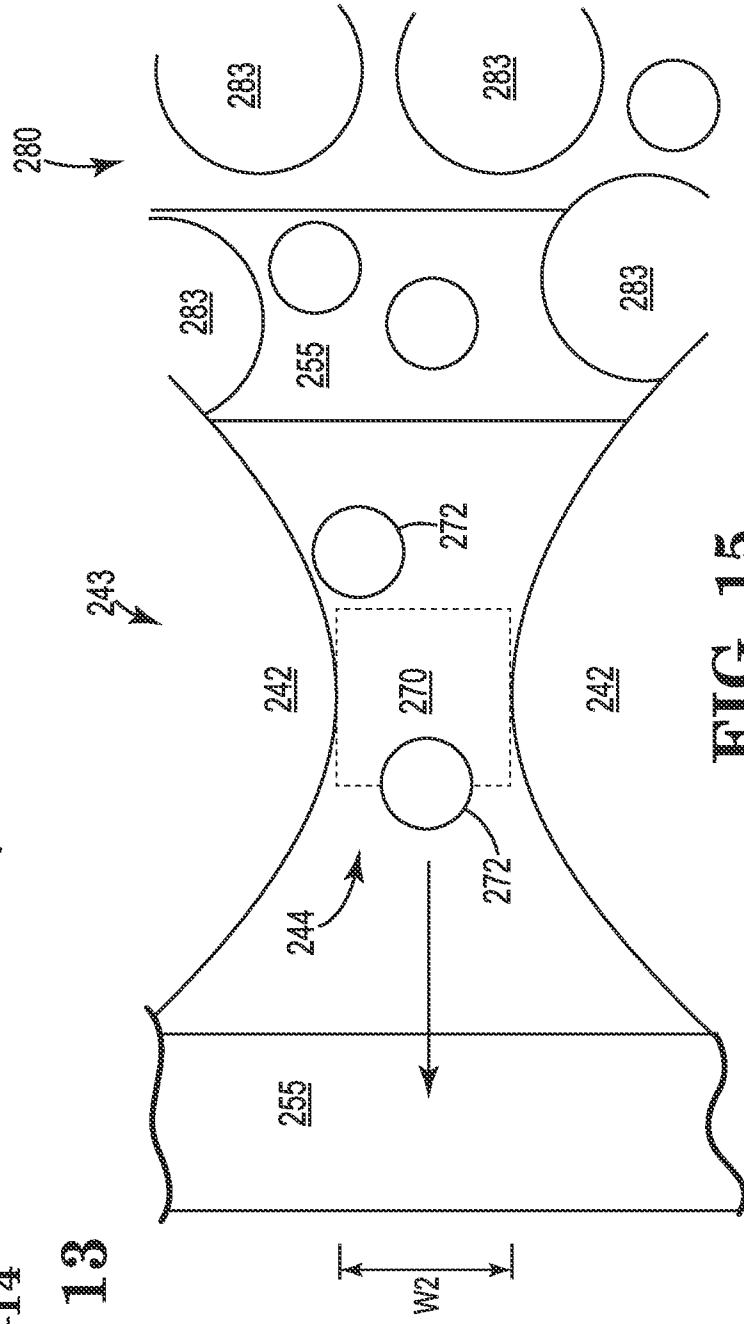

FIG. 15

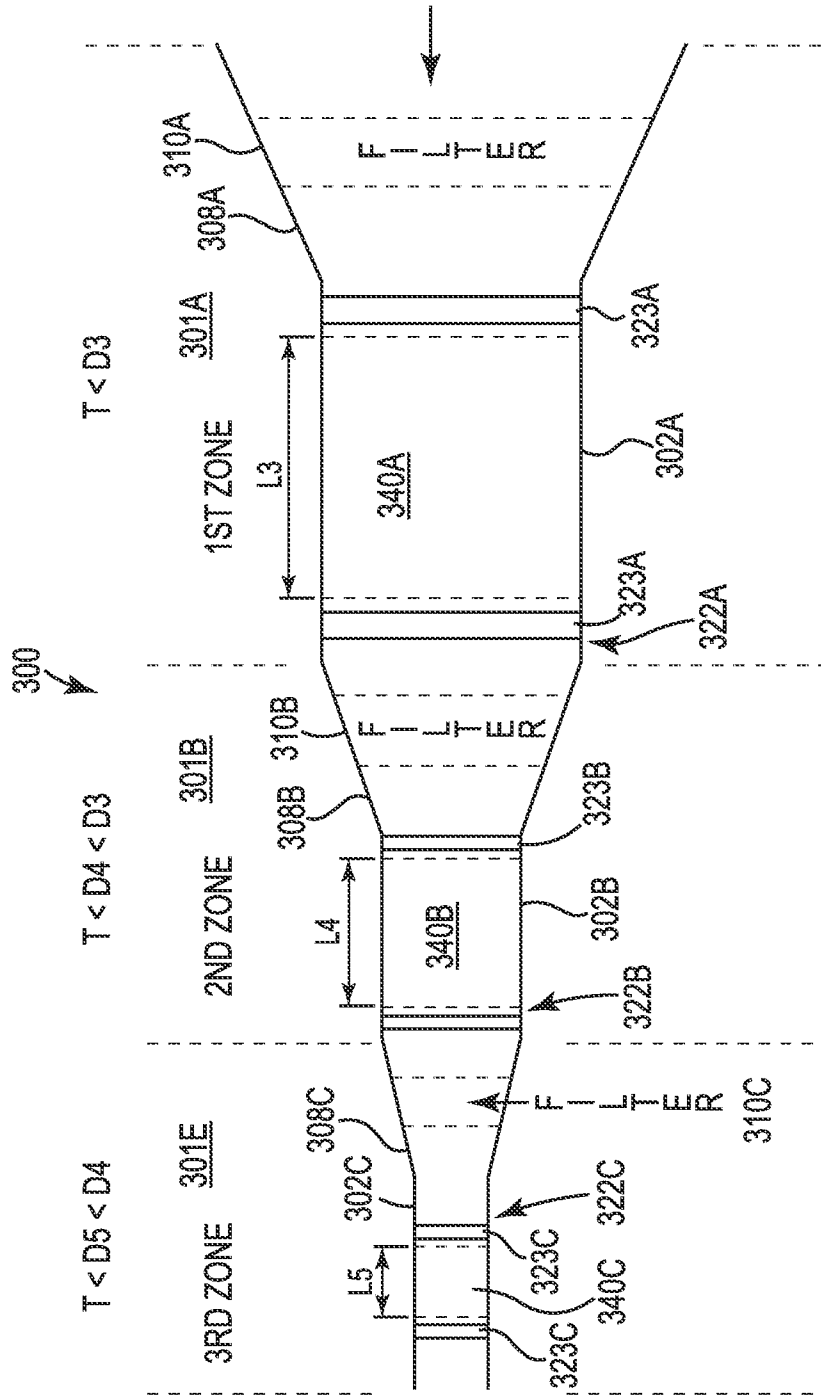

FIG. 16

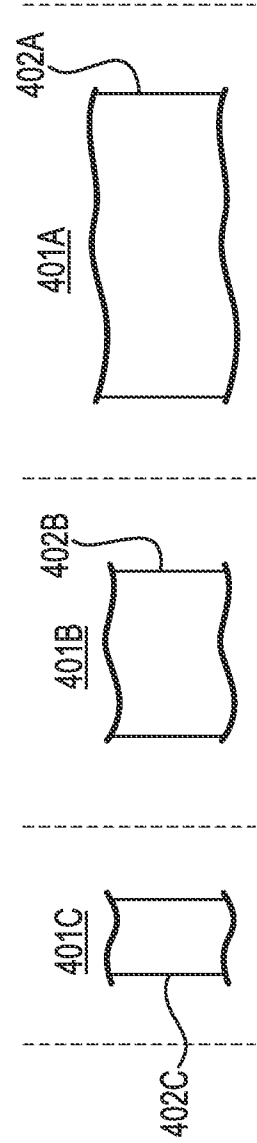

FIG. 17

INTERNATIONAL SEARCH REPORT

International application No.
PCT/US2015/013636**A. CLASSIFICATION OF SUBJECT MATTER****G01N 27/06(2006.01)i, G01N 33/48(2006.01)i, B81B 5/00(2006.01)i, B81B 1/00(2006.01)i**

According to International Patent Classification (IPC) or to both national classification and IPC

B. FIELDS SEARCHED

Minimum documentation searched (classification system followed by classification symbols)

G01N 27/06; H01L 23/31; G01N 27/00; G01N 35/08; G01N 33/66; G01N 33/48; G01N 27/327; G01N 15/14; G01R 27/08; B07C 5/02; G01T 1/20; B81B 5/00; B81B 1/00

Documentation searched other than minimum documentation to the extent that such documents are included in the fields searched

Korean utility models and applications for utility models
Japanese utility models and applications for utility modelsElectronic data base consulted during the international search (name of data base and, where practicable, search terms used)
eKOMPASS(KIPO internal) & Keywords: biologic test chip, microfluidic sensing, substrate, channel, actuator, sense region, volume, particle, volume and size**C. DOCUMENTS CONSIDERED TO BE RELEVANT**

Category*	Citation of document, with indication, where appropriate, of the relevant passages	Relevant to claim No.
Y	WO 2014-178827 A1 (HEWLETT-PACKARD DEVELOPMENT COMPANY, L.P.) 06 November 2014 See abstract, paragraphs [0004], [0015]-[0020], claims 7, 11 and figures 1-6.	1-15
Y	US 2011-0089328 A1 (LI, DONGQING) 21 April 2011 See abstract, paragraphs [0043]-[0051], claim 1 and figures 1, 2.	1-15
A	US 2012-0247964 A1 (LEE et al.) 04 October 2012 See abstract, paragraphs [0026], [0027], claim 1 and figure 1.	1-15
A	US 2014-0251879 A1 (DESHPANDE et al.) 11 September 2014 See abstract, paragraph [0040], claims 1, 23 and figure 1.	1-15
A	US 2013-0315782 A1 (HUANG, JUNG-TANG) 28 November 2013 See abstract, paragraph [0017], claim 1 and figures 1, 8.	1-15

 Further documents are listed in the continuation of Box C. See patent family annex.

* Special categories of cited documents:

"A" document defining the general state of the art which is not considered to be of particular relevance

"E" earlier application or patent but published on or after the international filing date

"L" document which may throw doubts on priority claim(s) or which is cited to establish the publication date of another citation or other special reason (as specified)

"O" document referring to an oral disclosure, use, exhibition or other means

"P" document published prior to the international filing date but later than the priority date claimed

"T" later document published after the international filing date or priority date and not in conflict with the application but cited to understand the principle or theory underlying the invention

"X" document of particular relevance; the claimed invention cannot be considered novel or cannot be considered to involve an inventive step when the document is taken alone

"Y" document of particular relevance; the claimed invention cannot be considered to involve an inventive step when the document is combined with one or more other such documents, such combination being obvious to a person skilled in the art

"&" document member of the same patent family

Date of the actual completion of the international search

20 October 2015 (20.10.2015)

Date of mailing of the international search report

21 October 2015 (21.10.2015)

Name and mailing address of the ISA/KR

 International Application Division
 Korean Intellectual Property Office
 189 Cheongsa-ro, Seo-gu, Daejeon Metropolitan City, 302-701,
 Republic of Korea

Facsimile No. +82-42-472-7140

Authorized officer

LEE, Hun Gil

Telephone No. +82-42-481-8525



INTERNATIONAL SEARCH REPORT

Information on patent family members

International application No.

PCT/US2015/013636

Patent document cited in search report	Publication date	Patent family member(s)	Publication date
WO 2014-178827 A1	06/11/2014	None	
US 2011-0089328 A1	21/04/2011	EP 2491383 A1 US 8188438 B2 WO 2011-049718 A1	29/08/2012 29/05/2012 28/04/2011
US 2012-0247964 A1	04/10/2012	KR 10-2012-0111878 A	11/10/2012
US 2014-0251879 A1	11/09/2014	US 2003-0234210 A1 US 2005-0183995 A1 US 2010-0032350 A1 US 2012-0012508 A1 US 6976590 B2 US 7569788 B2 US 8567608 B2 US 8727131 B2	25/12/2003 25/08/2005 11/02/2010 19/01/2012 20/12/2005 04/08/2009 29/10/2013 20/05/2014
US 2013-0315782 A1	28/11/2013	TW 201319563 A	16/05/2013