

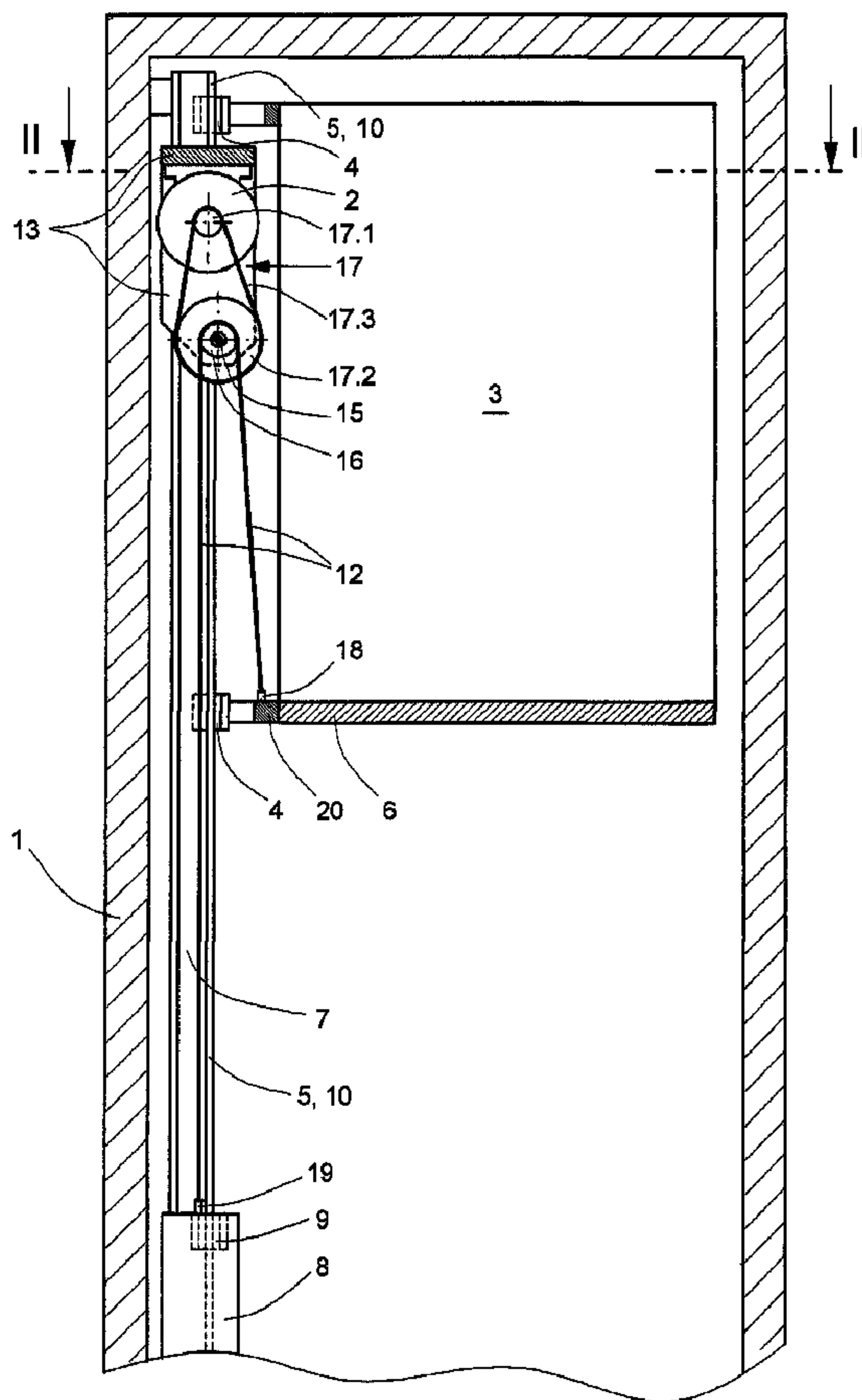

(86) Date de dépôt PCT/PCT Filing Date: 2002/11/22  
 (87) Date publication PCT/PCT Publication Date: 2003/05/30  
 (45) Date de délivrance/Issue Date: 2010/11/09  
 (85) Entrée phase nationale/National Entry: 2004/04/27  
 (86) N° demande PCT/PCT Application No.: CH 2002/000634  
 (87) N° publication PCT/PCT Publication No.: 2003/043926  
 (30) Priorité/Priority: 2001/11/23 (EP01811132.8)

(51) Cl.Int./Int.Cl. *B66B 11/00* (2006.01),  
*B66B 7/06* (2006.01), *D07B 1/22* (2006.01)  
 (72) Inventeurs/Inventors:  
ACH, ERNST FRIEDRICH, CH;  
CRUZ BELLO, PABLO, ES  
 (73) Propriétaire/Owner:  
INVENTIO AG, CH  
 (74) Agent: RICHES, MCKENZIE & HERBERT LLP

(54) Titre : SYSTEME D'ASCENSEUR  
 (54) Title: LIFT SYSTEM



(57) Abrégé/Abstract:

The invention relates to a lift system without a machinery room, comprising a driving motor (2), a driving disk (16), a protruding lift cage (3) and a counterweight (8). Said driving motor (2) drives, by means of the driving disk (16), a flat belt-type carrier means (12)

(57) **Abrégé(suite)/Abstract(continued):**

which is embodied as a V-ribbed belt, and which carries the lift cage (3) and the counterweight (8) and moves along vertical guiding mechanisms (5, 10). Said V-ribbed belt (12) comprises, at least on its bearing surface facing the driving disk (16), a plurality of ribs and grooves extending parallel in the longitudinal direction of the belt, said ribs and grooves improving the traction capacity of the carrier means.

## (12) NACH DEM VERTRAG ÜBER DIE INTERNATIONALE ZUSAMMENARBEIT AUF DEM GEBIET DES PATENTWESENS (PCT) VERÖFFENTLICHTE INTERNATIONALE ANMELDUNG

(19) Weltorganisation für geistiges Eigentum  
Internationales Büro(43) Internationales Veröffentlichungsdatum  
30. Mai 2003 (30.05.2003)

PCT

(10) Internationale Veröffentlichungsnummer  
WO 03/043926 A1(51) Internationale Patentklassifikation<sup>7</sup>: B66B 11/00

(21) Internationales Aktenzeichen: PCT/CH02/00634

(22) Internationales Anmeldedatum:  
22. November 2002 (22.11.2002)

(25) Einreichungssprache: Deutsch

(26) Veröffentlichungssprache: Deutsch

(30) Angaben zur Priorität:  
01811132.8 23. November 2001 (23.11.2001) EP

(71) Anmelder (für alle Bestimmungsstaaten mit Ausnahme von US): INVENTIO AG [CH/CH]; Seestrasse 55, Postfach, CH-6052 Hergiswil (CH).

(72) Erfinder; und

(75) Erfinder/Anmelder (nur für US): ACH, Ernst [DE/CH]; Ottigenbühlring 24, CH-6030 Ebikon (CH). CRUZ BELLO, Pablo [ES/ES]; Calle Carmelo Betore N° 2, Case 6, 2°-B, E-50014 Zaragoza (ES).

(74) Gemeinsamer Vertreter: INVENTIO AG; Seestrasse 55, Postfach, CH-6052 Hergiswil (CH).

(81) Bestimmungsstaaten (national): AE, AG, AL, AM, AT, AU, AZ, BA, BB, BG, BR, BY, BZ, CA, CH, CN, CO, CR, CU, CZ, DE, DK, DM, DZ, EC, EE, ES, FI, GB, GD, GE, GH, GM, HR, HU, ID, IL, IN, IS, JP, KE, KG, KP, KR, KZ, LC, LK, LR, LS, LT, LU, LV, MA, MD, MG, MK, MN, MW, MX, MZ, NO, NZ, OM, PH, PL, PT, RO, RU,

[Fortsetzung auf der nächsten Seite]

(54) Title: LIFT SYSTEM

(54) Bezeichnung: AUFZUGSSYSTEM

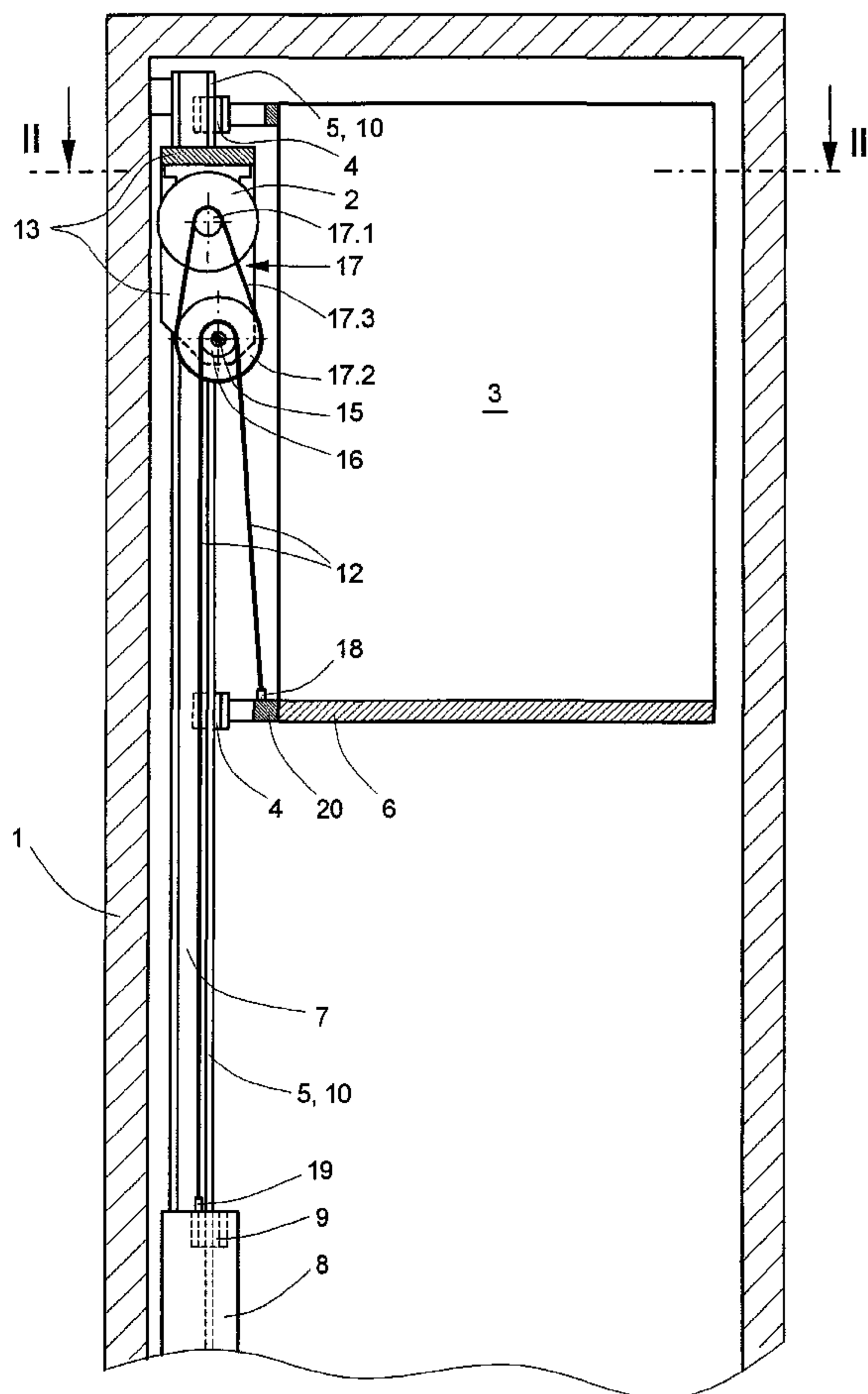

(57) Abstract: The invention relates to a lift system without a machinery room, comprising a driving motor (2), a driving disk (16), a protruding lift cage (3) and a counterweight (8). Said driving motor (2) drives, by means of the driving disk (16), a flat belt-type carrier means (12) which is embodied as a V-ribbed belt, and which carries the lift cage (3) and the counterweight (8) and moves along vertical guiding mechanisms (5, 10). Said V-ribbed belt (12) comprises, at least on its bearing surface facing the driving disk (16), a plurality of ribs and grooves extending parallel in the longitudinal direction of the belt, said ribs and grooves improving the traction capacity of the carrier means.

(57) Zusammenfassung: Ein maschinenraumloses Aufzugssystem umfasst eine Antriebsmaschine (2), eine Treibscheibe (16), eine Aufzugskabine (3) in Rucksackbauweise und ein Gegengewicht (8). Die Antriebsmaschine (2) treibt über die Treibscheibe (16) ein als Keilrippenriemen ausgebildetes, flachriemenartiges Tragmittel (12) an, das die Aufzugskabine (3) und das Gegengewicht (8) trägt und entlang von vertikalen Führungen (5, 10) bewegt. Der Keilrippenriemen (12) weist mindestens auf seiner der Treibscheibe (16) zugewandten Lauffläche mehrere in seiner Längsrichtung parallel verlaufende Rippen und Rillen auf, die die Traktionsfähigkeit des Tragmittels verbessern.

WO 03/043926 A1

**WO 03/043926 A1**



SC, SD, SE, SG, SI, SK, SL, TJ, TM, TN, TR, TT, TZ, UA,  
UG, US, UZ, VN, YU, ZA, ZM, ZW.

**(84) Bestimmungsstaaten (regional):** ARIPO-Patent (GH, GM, KE, LS, MW, MZ, SD, SL, SZ, TZ, UG, ZM, ZW), eurasisches Patent (AM, AZ, BY, KG, KZ, MD, RU, TJ, TM), europäisches Patent (AT, BE, BG, CH, CY, CZ, DE, DK, EE, ES, FI, FR, GB, GR, IE, IT, LU, MC, NL, PT, SE, SK, TR), OAPI-Patent (BF, BJ, CF, CG, CI, CM, GA, GN, GQ, GW, ML, MR, NE, SN, TD, TG).

**Veröffentlicht:**

— *mit internationalem Recherchenbericht*

*Zur Erklärung der Zweibuchstaben-Codes und der anderen Abkürzungen wird auf die Erklärungen ("Guidance Notes on Codes and Abbreviations") am Anfang jeder regulären Ausgabe der PCT-Gazette verwiesen.*

Lift system

The subject of the invention is a lift system, as defined in the patent claims.

5 Lift systems of the kind according to the invention usually comprise a lift cage and a counterweight which are movable in a lift shaft or along free-standing guide devices. The guide device for the lift cage in that case consists on the one hand of guide rails which are arranged in fixed position in the lift shaft at one side of the lift cage and on the other hand of cage guide rails fastened to a side of the lift cage. For producing the movement the lift  
10 system comprises at least one drive with at least one respective drive pulley which by way of support and drive means supports the lift cage and the counterweight and transmits the necessary drive forces to these.

The support means or drive means are termed support means in the following.

15

In the case of conventional lift systems, steel cables with a round cross-section are usually used as support means. However, flat, belt-like support means are increasingly used for more modern systems.

20 A lift system according to the cantilever principle with flat-belt-like support means is known from the technical article "Hannover Messe: Neue Idee von ContiTech - Hubgurte für Aufzüge" (ContiTech initiativ, January 1998).

The article discloses a lift for automobile body works in which a guide device, which  
25 comprises two guide columns, with integrated counterweight is present on one side of a lifting platform. At the upper end the two guide columns are connected together by a platform on which a drive motor is arranged, which acts by way of two drive pulleys on two flat support means strands by which the lifting platform and the counterweight can be moved upwardly and downwardly along the guide columns. In each instance one of the  
30 flat-belt-like support means is connected, on the side of the lifting platform facing the guide device, with the platform and extends from this support means fixing point vertically upwards to the side, which faces the lifting platform, of the periphery of the associated drive pulley, loops around this through 180° and then runs vertically downwards to a second support means fixing point present at the counterweight.

35

A drawing in the mentioned technical article indicates that with use of the same technique a passenger lift cage can also be moved instead of the lifting platform.

For simplification, in the following there is used, instead of different expressions for the form of lift receiving means, only the term "lift cage" which refers exclusively to load receiving means in "cantilever arrangement".

A lift system as described in the foregoing has, thanks to the use of flat-belt-like support means, the advantage that drive pulleys as well as deflecting rollers and support rollers can be used with a substantially smaller diameter than would be allowed in the case of use of a conventional wire cable. As a consequence of the smaller drive pulley diameter the drive torque required at the drive pulley reduces, whereby a drive motor with smaller dimensions can be used. Due to this and thanks to the generally smaller support means pulley diameter, particularly space-saving lift systems can be realised.

15

However, such lift systems have certain disadvantages.

As a consequence of the small drive pulley diameter and because, in the case of use of flat belts as support means, known measures for improving traction capability, for example undercutting of the cable grooves at the drive pulleys for round support means, are not usable, the problem can arise in the case of a relatively large weight ratio between fully laden and empty lifting platform or lift cage that the traction forces transmissible between drive pulley and flat-belt-like traction means are not sufficient.

In addition, it is known that in the case of use of flat-belt-like support means without profiling the running surface, significant problems arise with lateral guidance of the support means on the drive pulley and, if they should be present, deflecting rollers and support rollers. Experience has shown that there is the risk that the support means rubs so strongly against the lateral boundary discs, which are usually present at the drive pulleys, deflecting rollers and support rollers, that the support means are damaged.

35

The present invention has the object of creating a lift system in cantilever mode of construction with flat-belt-like support means which does not have the stated disadvantages.

Accordingly, the objective of the present invention is fulfilled in one aspect of the invention where there is provided a lift system without an engine room, which comprises a drive motor, a drive pulley, a lift cage in cantilever mode of construction, a counterweight and vertical guide rails, which are arranged on one side of the lift cage, for the lift cage and the counterweight, wherein the drive motor by way of the drive pulley drives at least one of a flat-belt-like support and drive means which supports the lift cage and the counterweight and moves them along the vertical guide rails, characterised in that at least one of the flat-belt-like support and drive means is a wedge-ribbed belt which on a running surface facing the drive pulley has several ribs and grooves running parallelly in belt longitudinal direction.

The proposed solution substantially consists in replacing the flat-belt-like support means with flat running surfaces by a wedge-ribbed belt. A wedge-ribbed belt has in the region of its running surface several ribs and grooves which extend parallelly in belt longitudinal direction and the cross-sections of which exhibit flanks extending in wedge shape. When running around the drive pulley, at the periphery of which ribs and grooves are similarly present and are complementary to those of the wedge-ribbed belt, the wedge-shaped ribs of the wedge-ribbed belt are pressed into the wedge-shaped grooves of the drive pulley. In that case, as a consequence of the wedge shape the perpendicular forces arising between drive pulley and wedge-ribbed belt increase so that an improvement in the traction capability between drive pulley and belt results.

Moreover, the interengagement of the ribs and grooves of the wedge-ribbed belt in those of the pulley and rollers ensures an excellent lateral guidance of the support means distributed over several rib and groove flanks.

The lift system according to the invention obviously also embraces embodiments with at least two support means strands (wedge-ribbed belts) arranged parallel to one another.

According to a preferred refinement of the invention the cross-sections of the ribs and grooves of the wedge-ribbed belt are substantially triangular or trapezium-shaped.

Wedge-ribbed belts with triangular or trapezium-shaped ribs and grooves can be manufactured particularly simply and economically.

3a

An advantageous compromise between the demands on running quietness and on traction capability is achieved if the triangular or wedge-shaped ribs and grooves have between the lateral flanks thereof an angle (b) which lies between  $80^\circ$  and  $100^\circ$ .

In a particularly suitable form of embodiment of the lift system according to the invention wedge-ribbed belts are present in which the angle (b) between the lateral flanks of the ribs and grooves amounts to  $90^\circ$ .

Wedge-ribbed belts which allow particularly small bending radii, i.e. are suitable for use in combination with drive pulleys, deflecting rollers and support rollers with particularly small diameters, have transverse grooves on a side provided with ribs and grooves. The bending stresses, which arise when running around pulleys and rollers, in the wedge-  
5 ribbed belt are thus substantially reduced.

To ensure sufficient operational safety of the lift system several separate wedge-ribbed belts arranged parallel to one another are provided as support means.

10 Particularly significant advantages with respect to the torque required at the drive pulley and thus the dimensions of the drive motor as well as with respect to the overall dimensions of the lift installation are achieved by a lift system according to the invention if at least the drive pulley, but also all deflecting or support rollers which may happen to be present have an outer diameter of 70 millimetres to 100 millimetres. Previous tests have  
15 led to recognition that the diverse requirements and load limits can be fulfilled in optimum manner by pulley and roller diameters of 85 millimetres.

According to a preferred form of embodiment of the invention two vertical guide columns are installed in stationary position on one side of the lift cage and have guide rails for the  
20 counterweight and lift cage arranged between the guide columns. The drive motor, drive pulley shaft and drive pulley are in that case mounted on a drive bracket which is carried by at least one of the guide columns. It is thus achieved that the vertical loads, which act on the drive pulley, and the weight of the drive motor are for the greatest part conducted by way of the guide columns into the foundation of the lift shaft and do not load the walls of  
25 the lift shaft.

The drive motor, which is equipped with an integrated brake, the drive pulley shaft and the drive pulley are placed in a space which lies between the wall, which is at the guide side, of the lift cage disposed in its uppermost position and the wall, which is at the guide side,  
30 of the lift shaft, wherein the axis of the drive pulley is arranged horizontally and parallel to the wall of the lift cage at the guide side. With this lift arrangement the dimensions, which turn out to be small thanks to the use of wedge-ribbed belts as support means, of the drive pulleys and the drive motor are used for the purpose of so arranging the entire drive that only a minimum shaft head height is required above the lift cage standing in its uppermost  
35 position.

The wedge-ribbed belt serving as support means is connected on the side, which faces the guide device, of the lift cage at a first support means fixing point with this, extends from this first support means fixing point vertically upwards to the side, which faces the lift cage, of the periphery of the associated drive pulley, loops around the drive pulley by 180° and then runs vertically downwards to a second support means fixing point present at the counterweight. This particularly simple and economic support means arrangement can be realised, in the case of a large ratio between the weights of the full and the empty lift cage, virtually only thanks to the increased traction capability of the wedge-ribbed belt.

An additional reduction in the dimensions of the drive motor and thus a minimisation of the installation space, which is required between the wall of the lift cage at the guide side and the wall of the lift shaft at the guide side, for the drive can be achieved in that there is installed between the drive output shaft of the drive motor and the drive pulley shaft a belt transmission by which the drive output torque of the drive motor required at the drive output shaft of the drive motor is reduced.

A high degree of operational safety of the belt transmission with virtually slip-free torque transmission can be achieved if the transmission is realised with cogged belt or with wedge-ribbed belt.

In one aspect of the present invention, there is provided an elevator system comprising: a drive motor mounted at a head of an elevator shaft and having a drive pulley; an elevator car movable in the elevator shaft in a cantilever mode along guide rails positioned at one side of said elevator car; a counterweight movable in the elevator shaft and arranged laterally of said elevator car; and a flat-belt-like support means supporting said elevator car and engaging said drive pulley, said support means being a wedge-ribbed belt having a running surface facing said drive pulley and a plurality of ribs and grooves formed in said running surface and extending in parallel in a longitudinal direction of said support means, said ribs and grooves being one of triangular-shaped and trapezium-shaped in cross section and formed with lateral flanks at an angle in a range of 80° to 100°.

In another aspect of the present invention, there is provided an elevator car support for use in an elevator system having a drive motor mounted at a head of an elevator shaft and having a drive pulley for engaging the support, the support comprising: a wedge-

## 5a

ribbed belt adapted to support the elevator car in a cantilever mode and engaging the drive pulley, said belt having a running surface adapted to face the drive pulley and a plurality of ribs and grooves formed in said running surface and extending in parallel in a longitudinal direction of said belt, said ribs and grooves being one of triangular-shaped and trapezium-shaped in cross section and being formed with lateral flanks at an angle in a range of 80° to 100°.

An example of embodiment of the invention is explained on the basis of the accompanying drawings, in which:

- Fig. 1 shows a section, which is parallel to a lift cage front, through a lift system according to the invention,
- Fig. 2 shows a horizontal section through the lift system,
- Fig. 3 shows a wedge-ribbed belt according to the invention with triangular ribs and grooves and
- Fig. 4 shows a wedge-ribbed belt according to the invention with trapezium-shaped ribs and grooves.

Figs. 1 and 2 show a lift system according to the invention. Fig. 1 corresponds with a section through the lift cage parallel to its front. Fig. 2 illustrates a horizontal section, which is taken through the shaft head region, through the lift system, the position of which is marked in Fig. 1 by II - II. A lift shaft is characterised by reference numeral 1, in which a drive motor 2 moves, by way of a drive pulley 16 and flat-belt-like support means 12, a lift cage 3 of cantilever mode of construction and a counterweight 8 upwardly and downwardly. The lift cage 3 is guided by means of cage guide shoes 4 at two cage guide rails 5 and the counterweight 8 is guided by means of counterweight guide shoes 9 at two counterweight guide rails 10. The mentioned guide rails are each part of two vertical guide columns 7, which are fixed laterally of the lift cage 3 in stationary position in the lift shaft 1.

The drive motor 2, preferably an asynchronous motor with integrated brake unit, is arranged in the shaft head region between the wall, which is at the guide side, of the lift cage 3 standing in its uppermost position and the wall, which is at the guide side, of the lift shaft 1 and drives the drive pulley 16 which acts on several wedge-ribbed belts 12 by way of a belt transmission 17. The axis of the drive pulley 16 is arranged horizontally and parallelly to the wall of the lift cage at the guide side. In order to be able to design the mentioned installation space for the drive to be as narrow as possible the support means 12 are constructed as wedge-ribbed belts. It is thereby achieved that a drive pulley 16 with a diameter of 70 millimetres to 100 millimetres - preferably 85 millimetres - is sufficient in order to transmit the necessary traction force to the support means and in that case to avoid an impermissibly high loading of the support means in bending. Thanks to the small drive pulley diameter the torque to be applied to the drive pulley shaft is, for a given traction force, correspondingly small. The drive torque demanded of the drive motor 2 is additionally reduced with the help of the belt transmission 17. Since the diameter of electric motors is approximately proportional to the torque which can be generated, the dimensions of the drive motor 2 and thus of the entire installation space for the described drive arrangement are kept to a minimum.

The drive motor 2, the one motor belt pulley 17.1, a belt pulley 17.2 acting on the drive pulley shaft 15 as well as a belt transmission 17, which comprises cogged belts or wedge-ribbed belts 17.3, and the drive pulley shaft 15 with the drive pulley 16 are fastened to or mounted on a drive bracket 13 which is fastened to the two guide columns 7. The weight forces and acceleration forces from the lift cage 3 and the counterweight 8 and acting by way of the support means on the drive pulley are for the greatest part conducted by way of

the guide columns 7 into the foundation of the lift shaft 7 so that the walls of the lift shaft 1 are not loaded.

The wedge-ribbed belts 12 serving as support means are fastened by one end thereof to a beam 20 projecting at the guide side from the cage floor 6 of the lift cage 3. From this first support means fixing point 8 the wedge-ribbed belt 12 extends upwards to the side, which faces the lift cage 3, of the periphery of the drive pulley 16, loops around this by approximately 180°, and extends from the side, which is remote from the lift cage, of the periphery of the drive pulley downwardly to a second support means fixing point 19 present at the upper side of the counterweight 8.

The present description always refers, for the sake of simplicity, to a lift system with several support means strands arranged parallel to one another. The drive pulley can in that case be integral or assembled from several wedge-ribbed discs. Obviously, the lift system according to the invention can also be constructed with only one support means strand (wedge-ribbed belt) insofar as this guarantees the actually required operating safety.

Figs. 3 and 4 show possible forms of embodiment 12.1 and 12.2 of a wedge-ribbed belt 12, which is usable for the lift system according to the invention, with ribs 23 and grooves 24 oriented in longitudinal direction of the belt. Preferably at least that layer of the wedge-ribbed belt 12 containing the ribs and grooves is made of polyurethane.

In Figs. 3 and 4 it can also be recognised that the wedge-ribbed belt 12 contains tensile carriers 25 which are oriented in the longitudinal direction thereof and which consist of metallic strands (for example, steel strands) or non-metallic strands (for example, of synthetic fibres or chemical fibres). Tensile carriers can also be present in the form of metallic flat pieces of fabric or flat pieces of fabric made from synthetic fibres. Tensile carriers impart to the wedge-ribbed belt 12 the requisite tensile strength and/or longitudinal stiffness.

In the case of the form of embodiment according to Fig. 3 the ribs and grooves have a triangular cross-section and in the case of that according to Fig. 4 a trapezium-shaped cross-section. The angle  $b$  present between the flanks of a rib or a groove influences the operating characteristics of a wedge-ribbed belt, particularly the running quietness thereof

and the traction capability thereof. Tests have shown that it is applicable within certain limits that the larger the angle  $b$  the better the running quietness and the worse the traction capability. With consideration of the demands on running quietness as well as traction capability the angle  $b$  should lie between  $80^\circ$  and  $100^\circ$ . An optimum compromise between  
5 the opposing requirements is achieved by wedge-ribbed belts in which the angle  $b$  lies at approximately  $90^\circ$ .

A further possibility of embodiment of the wedge-ribbed belt 12 is recognisable from Fig. 4. The wedge-ribbed belt 12 has, apart from the wedge-shaped ribs 23 and grooves 24, also  
10 transverse grooves 26. These transverse grooves 26 improve the flexibility of the wedge-ribbed belt 12 in bending so that this can co-operate with belt pulleys with extremely small diameters.

## Patent Claims

1. Lift system without an engine room, which comprises a drive motor (2), a drive pulley (16), a lift cage (3) in cantilever mode of construction, a counterweight (8) and vertical guide rails (5, 10), which are arranged on one side of the lift cage, for the lift cage and the counterweight, wherein the drive motor (2) by way of the drive pulley (16) drives at least one of a flat-belt-like support and drive means (12) which supports the lift cage (3) and the counterweight (8) and moves them along the vertical guide rails (5, 10), characterised in that at least one of the flat-belt-like support and drive means is a wedge-ribbed belt (12) which on a running surface facing the drive pulley (16) has several ribs (23) and grooves (24) running parallelly in belt longitudinal direction.
2. Lift system according to claim 1, characterised in that the cross-sections of the ribs (23) and grooves (24) are substantially triangular or trapezium-shaped.
3. Lift system according to claim 2, characterised in that the triangular or trapezium-shaped ribs (23) and grooves (24) have between their lateral flanks an angle (b) which lies between 80° and 100°.
4. Lift system according to claim 3, characterised in that the angle (b) is 90°.
5. Lift system according to any one of claims 1 to 4, characterised in that the wedge-ribbed belt (12) has transverse grooves (26) on its running surface.
6. Lift system according to any one of claims 1 to 5, characterised in that several separate wedge-ribbed belts (12) arranged in parallel are provided as the support means.
7. Lift system according to any one of claims 1 to 6, characterised in that the drive pulley (16) has an external diameter of 70 millimetres to 100 millimetres.
8. Lift system according to any one of claims 1 to 7, characterised in that installed on one side of the lift cage (3) in stationary location are two vertical guide columns (7) which each have a respective counterweight guide rail (10) for the counterweight (8) arranged between the guide columns (7) and a respective

cage guide rail (5) for the lift cage and that at least the drive motor (2) and the drive pulley (16) are mounted on a drive bracket (13) carried by at least one of the guide columns (7).

9. Lift system according to any one of claims 1 to 8, characterised in that at least the drive motor (2) and the drive pulley (16) are placed in a space which lies between the wall, which is at the guide side, of the lift cage (3) standing in uppermost position and the wall, which is at the guide side, of the lift shaft (1) and that the axis of the drive pulley is arranged horizontally and parallelly to the wall, which is that the guide side, of the lift cage (3).
10. Lift system according to any one of claims 1 to 9, characterised in that the wedge-ribbed belt (12) serving as support means is connected on the side, which faces the guide rails (5, 10), of the lift cage (3) at a first support means fixing point (18) with this, extends from this support means fixing point vertically upwards to the side, which faces the lift cage (3), of the periphery of the drive pulley (16), loops around the drive pulley by 180° and then runs vertically downwards to a second support means fixing point (19) present at the counterweight (8).
11. Lift system according to any one of claims 1 to 10, characterised in that a belt transmission (17, 17.1, 17.2, 17.3) is present between the drive motor (2) and the drive pulley (16).
12. Lift system according to claim 11, characterised in that the belt transmission (17) is realised by at least one cogged belt or wedge-ribbed belt.

13. An elevator system comprising:
  - a drive motor mounted at a head of an elevator shaft and having a drive pulley;
  - an elevator car movable in the elevator shaft in a cantilever mode along guide rails positioned at one side of said elevator car;
  - a counterweight movable in the elevator shaft and arranged laterally of said elevator car; and
  - a flat-belt-like support means supporting said elevator car and engaging said drive pulley, said support means being a wedge-ribbed belt having a running surface facing said drive pulley and a plurality of ribs and grooves formed in said running surface and extending in parallel in a longitudinal direction of said support means, said ribs and grooves being one of triangular-shaped and trapezium-shaped in cross section and formed with lateral flanks at an angle in a range of  $80^{\circ}$  to  $100^{\circ}$ .
14. The elevator system according to claim 13 wherein said angle is  $90^{\circ}$ .
15. The elevator system according to claim 13 wherein said wedge-ribbed belt has a plurality of transverse grooves formed in said running surface.
16. The elevator system according to claim 13 wherein said support means includes at least two wedge-ribbed belt strands arranged in parallel.
17. The elevator system according to claim 13 wherein said drive pulley has an external diameter in a range of 70 millimeters to 100 millimeters.
18. The elevator system according to claim 13 including a pair of vertical guide columns mounted in the elevator shaft at said one side of said elevator car, each said guide column having one of said car guide rails and a counterweight guide rail formed thereon, and wherein said drive motor together with said drive pulley are mounted on a drive bracket attached to at least one of said guide columns.
19. The elevator system according to claim 13 wherein said drive motor and said drive pulley are mounted in a space which lies between said one side of said

elevator car, when said elevator car is standing in an uppermost position in the elevator shaft, and an adjacent wall of the elevator shaft and an axis of said drive pulley is arranged horizontally and parallel to said one side of said elevator car.

20. The elevator system according to claim 13 wherein said wedge-ribbed belt is connected at one end at said one side of said elevator car at a first support means fixing point extends from said first support means fixing point vertically upwards to a side, which faces said elevator car, of a periphery of said drive pulley, loops around said drive pulley by 180° and then runs vertically downwards to a second support means fixing point at said counterweight.
21. The elevator system according to claim 13 including a belt transmission means coupling said drive motor to said drive pulley.
22. The elevator system according to claim 21 wherein said belt transmission means includes at least one of a cogged belt and a wedge-ribbed belt coupling said drive motor to said drive pulley.
23. An elevator car support for use in an elevator system having a drive motor mounted at a head of an elevator shaft and having a drive pulley for engaging the support, the support comprising: a wedge-ribbed belt adapted to support the elevator car in a cantilever mode and engaging the drive pulley, said belt having a running surface adapted to face the drive pulley and a plurality of ribs and grooves formed in said running surface and extending in parallel in a longitudinal direction of said belt, said ribs and grooves being one of triangular-shaped and trapezium-shaped in cross section and being formed with lateral flanks at an angle in a range of 80° to 100°.

Fig. 1

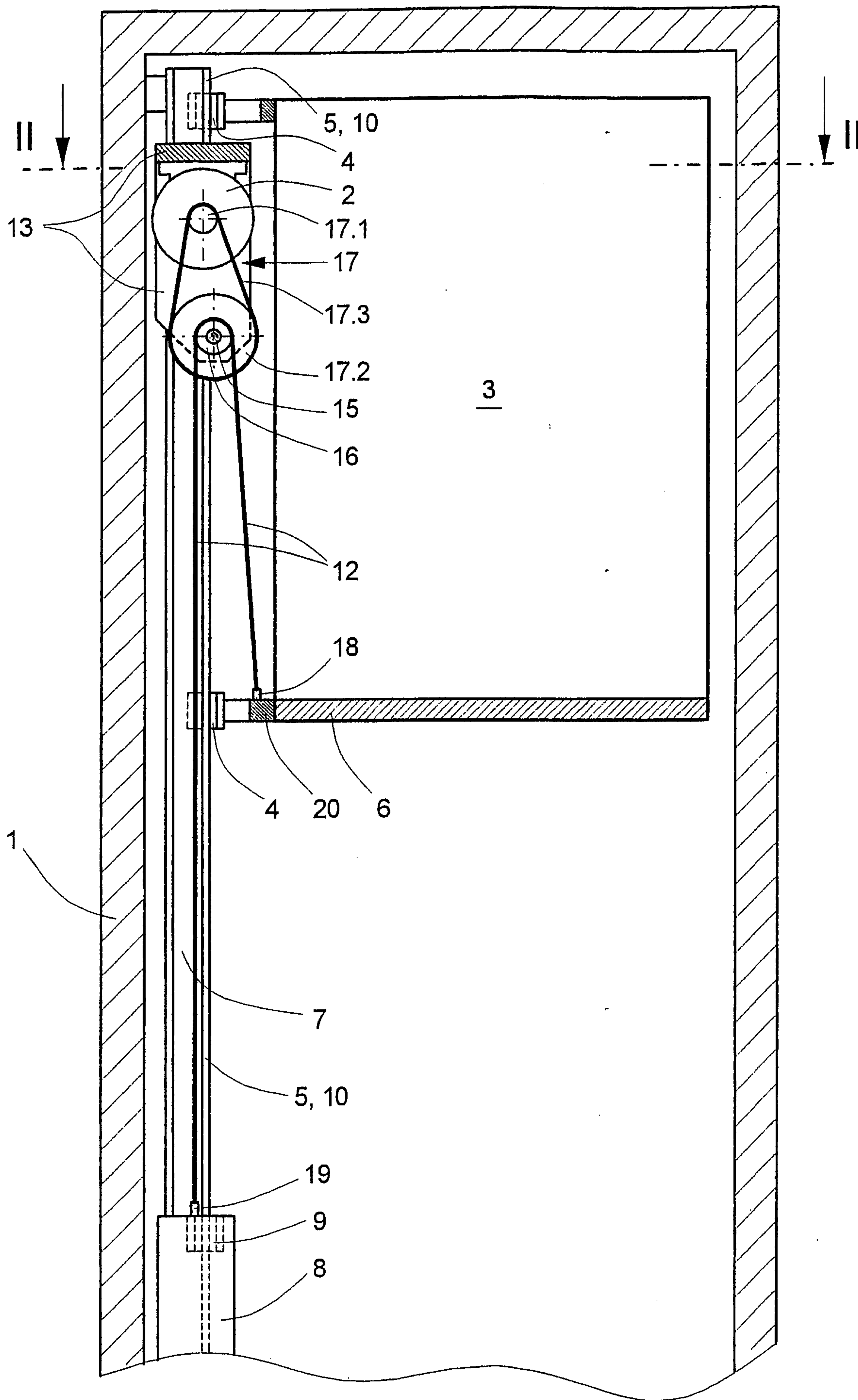

Fig. 2

