



HU000027242T2

(19) **HU**(11) Lajstromszám: **E 027 242**(13) **T2****MAGYARORSZÁG**
Szellemi Tulajdon Nemzeti Hivatala**EURÓPAI SZABADALOM**
SZÖVEGÉNEK FORDÍTÁSA(21) Magyar ügyszám: **E 13 725836**
(22) A bejelentés napja: **2013. 05. 16.**(51) Int. Cl.: **H04B 17/00** (2006.01)
H04J 11/00 (2006.01)(96) Az európai bejelentés bejelentési száma:
EP 20130725836(86) A nemzetközi (PCT) bejelentési szám:
PCT/SE 13/000080(97) Az európai bejelentés közzétételi adatai:
EP 2850752 A1 **2013. 11. 21.**(87) A nemzetközi közzétételi szám:
WO 13172760(97) Az európai szabadalom megadásának meghirdetési adatai:
EP 2850752 B1 **2016. 03. 23.**(30) Elsőbbségi adatok:
PCT/SE2012/000077 **2012. 05. 16.** **WO**
201261707566 P **2012. 09. 28.** **US**(73) Jogosult(ak):
Telefonaktiebolaget LM Ericsson (publ), 164
83 Stockholm (SE)(72) Feltalálók(k):
HAMMARWALL, David, SE-186 53 Vallentuna (SE)
Jöngren, George, SE-174 62 Sundbyberg (SE)
BERGMAN, Svante, SE-129 36 Hägersten (SE)
FRÖBERG OLSSON, Jonas, SE-590 74 Ljungsbro (SE)(74) Képviselő:
SBGK Szabadalmi Ügyvivői Iroda, Budapest(54) **Eljárás és elrendezés vezeték nélküli kommunikációs rendszerben**

Az európai szabadalom ellen, megadásának az Európai Szabadalmi Közlönyben való meghirdetésétől számított kilenc hónapon belül, felszólalást lehet benyújtani az Európai Szabadalmi Hivatalnál. (Európai Szabadalmi Egyezmény 99. cikk(1))

A fordítást a szabadalmas az 1995. évi XXXIII. törvény 84/H. §-a szerint nyújtotta be. A fordítás tartalmi helyességét a Szellemi Tulajdon Nemzeti Hivatala nem vizsgálta.

(19)



(11)

EP 2 850 752 B1

(12)

EUROPEAN PATENT SPECIFICATION

(45) Date of publication and mention of the grant of the patent:
23.03.2016 Bulletin 2016/12

(51) Int Cl.:
H04B 17/100 (2015.01) H04J 11/100 (2006.01)

(21) Application number: **13725836.4**

(86) International application number:
PCT/SE2013/000080

(22) Date of filing: **16.05.2013**

(87) International publication number:
WO 2013/172760 (21.11.2013 Gazette 2013/47)

(54) METHOD AND ARRANGEMENT IN A WIRELESS COMMUNICATION SYSTEM

VERFAHREN UND ANORDNUNG IN EINEM DRAHTLOSEN KOMMUNIKATIONSSYSTEM

PROCÉDÉ ET AGENCEMENT DANS UN SYSTÈME DE COMMUNICATION SANS FIL

(84) Designated Contracting States:
AL AT BE BG CH CY CZ DE DK EE ES FI FR GB GR HR HU IE IS IT LI LT LU LV MC MK MT NL NO PL PT RO RS SE SI SK SM TR

(30) Priority: **16.05.2012 PCT/SE2012/000077**
28.09.2012 US 201261707566 P

(43) Date of publication of application:
25.03.2015 Bulletin 2015/13

(73) Proprietor: **Telefonaktiebolaget LM Ericsson (publ)**
164 83 Stockholm (SE)

(72) Inventors:
• **HAMMARWALL, David**
SE-186 53 Vallentuna (SE)
• **JÖNGREN, George**
SE-174 62 Sundbyberg (SE)
• **BERGMAN, Svante**
SE-129 36 Hägersten (SE)
• **FRÖBERG OLSSON, Jonas**
SE-590 74 Ljungsbro (SE)

(74) Representative: **Ericsson Patent Development**
Torshamnsgatan 21-23
164 80 Stockholm (SE)

(56) References cited:
• **ERICSSON ET AL: "Comp Interference averaging", 3GPP DRAFT; R4-130528 IMR AVERAGINGV2, 3RD GENERATION PARTNERSHIP PROJECT (3GPP), MOBILE COMPETENCE CENTRE ; 650, ROUTE DES LUCIOLES ; F-06921 SOPHIA-ANTIPOLIS CEDEX ; FRANCE , vol. RAN WG4, no. St. Julian; 20130128 - 20130201 21 January 2013 (2013-01-21), XP050674966, Retrieved from the Internet:
URL:http://www.3gpp.org/ftp/tsg_ran/WG4_Radio/TSGR4_66/Docs/ [retrieved on 2013-01-21]**
• **ALCATEL-LUCENT ET AL: "Interference Measurement for CoMP", 3GPP DRAFT; R1-122482 COMP_INTERFERENCE, 3RD GENERATION PARTNERSHIP PROJECT (3GPP), MOBILE COMPETENCE CENTRE ; 650, ROUTE DES LUCIOLES ; F-06921 SOPHIA-ANTIPOLIS CEDEX ; FRANCE, vol. RAN WG1, no. Prague, Czech; 20120521 - 20120525, 13 May 2012 (2012-05-13), XP050601106,**
• **ERICSSON ET AL: "CQI Definition of UE Emulated Intra CoMP Cluster Interference", 3GPP DRAFT; R1-121740, 3RD GENERATION PARTNERSHIP PROJECT (3GPP), MOBILE COMPETENCE CENTRE ; 650, ROUTE DES LUCIOLES ; F-06921 SOPHIA-ANTIPOLIS CEDEX ; FRANCE, vol. RAN WG1, no. Jeju, Korea; 20120326 - 20120330, 20 March 2012 (2012-03-20), XP050599994,**

EP 2 850 752 B1

Note: Within nine months of the publication of the mention of the grant of the European patent in the European Patent Bulletin, any person may give notice to the European Patent Office of opposition to that patent, in accordance with the Implementing Regulations. Notice of opposition shall not be deemed to have been filed until the opposition fee has been paid. (Art. 99(1) European Patent Convention).

Description

TECHNICAL FIELD

5 **[0001]** The present disclosure relates generally to methods and arrangements in a wireless communications system. In particular it relates to interference measurements in a wireless communication system.

BACKGROUND

10 **[0002]** In a wireless communications system or cellular radio communications system wireless devices and/or user equipments, also known as mobile terminals and/or wireless terminals, communicate via a Radio Access Network (RAN) with one or more core networks. The user equipments may be mobile stations or user equipment units such as mobile telephones, also known as "cellular" telephones, and laptops with wireless capability, e.g., mobile termination, and may thus be, for example, portable, pocket, hand-held, computer-included, or car-mounted mobile devices which communicate voice and/or data via the radio access network. A wireless device may be any equipment being wirelessly connectable to a RAN for wireless communication.

15 **[0003]** The radio access network covers a geographical area which is divided into point coverage areas, traditionally denoted cells, with each point coverage area or cell being served by a base station, e.g., a Radio Base Station (RBS), which in some networks is also called "eNB", "eNodeB", "NodeB" or "B node" and which in this document also is referred to as a base station or radio network node. A point coverage area is a geographical area where radio coverage is provided by a point, also referred to as a "transmission point" and/or a "reception point", which is controlled by the radio base station or radio network node at a base station site or radio network node site. A point coverage area is often also denoted a cell, but the concept of a cell also has architectural implications and the transmission of certain reference signals and system information. More specifically, multiple point coverage areas may jointly form a single logical cell sharing the same physical cell ID. However, in the following the notation of a "cell" is used interchangeably with "point coverage area" to have the meaning of the latter. Moreover, a point, or "transmission point" and/or a "reception point", corresponds in the present disclosure to a set of antennas covering essentially the same geographical area in a similar manner. Thus, a point might correspond to one of the sectors at a site, e.g. a base station site, but it may also correspond to a site having one or more antennas all intending to cover a similar geographical area. Often, different points represent different sites. Antennas correspond to different points when they are sufficiently geographically separated and/or have antenna diagrams pointing in sufficiently different directions.

20 **[0004]** The radio network node communicates over an air interface or radio interface with the user equipments within the range of the radio network node. One radio network node may serve one or more cells via one or more antennas operating on radio frequencies. The cells may be overlaid on each other, e.g. as macro and pico cells having different coverage areas, or adjacent to each other, e.g. as so called sector cells where the cells served by the radio network node each cover a section of the total area or range covered by the radio network node. The cells adjacent or overlaid relative to each other may alternatively or additionally be served by different or separate radio network nodes that may be co-located or geographically separated.

25 **[0005]** The one or more antennas controlled by the radio network node may be located at the site of the radio network node or at antenna sites that may be geographically separated from each other and from the site of the radio network node. There may also be one or more antennas at each antenna site. The one or more antennas at an antenna site may be arranged as an antenna array covering the same geographical area or arranged so that different antennas at the antenna site have different geographical coverage. An antenna array may also be co-located at one antenna site with antennas that have different geographical coverage as compared to the antenna array. In the subsequent discussion an antenna or antenna array covering a certain geographical area is referred to as a point, or transmission and/or reception point, or more specifically for the context of this disclosure as a *Transmission Point* (TP). In this context multiple transmission points may share the same physical antenna elements, but could use different virtualizations, e.g., different beam directions.

30 **[0006]** The communications, i.e. transmission and reception of signals between the radio access network and a user equipment, may be performed over a communication link or communication channel via one or more transmission and/or reception points that may be controlled by the same or different radio network nodes. A signal may thus, for example, be transmitted from multiple antennas by being transmitted via one transmission point from more than one antenna in an antenna array or by being transmitted via more than one transmission point from one antenna at each transmission point. The coupling between a transmitted signal and a corresponding received signal over the communication link may be modelled as an effective channel comprising the radio propagation channel, antenna gains, and any possible antenna visualizations. Antenna virtualization is obtained by precoding a signal so that it can be transmitted on multiple physical antennas, possibly with different gains and phases. Link adaptation may be used to adapt transmission and reception over the communication link to the radio propagation conditions.

[0007] An antenna port is a "virtual" antenna, which is defined by an antenna port-specific reference signal. An antenna port is defined such that the channel over which a symbol on the antenna port is conveyed can be inferred from the channel over which another symbol on the same antenna port is conveyed. The signal corresponding to an antenna port may possibly be transmitted by several physical antennas, which may also be geographically distributed. In other words, an antenna port may be virtualized over one or several transmission points. Conversely, one transmission point may transmit one or several antenna ports.

[0008] Multi-antenna techniques can significantly increase the data rates and reliability of a wireless communication system. The performance is in particular improved if both the transmitter and the receiver are equipped with multiple antennas, which results in a multiple-input multiple-output (MIMO) communication channel. Such systems and/or related techniques are commonly referred to as MIMO.

[0009] The Long Term Evolution (LTE) standard is currently evolving with enhanced MIMO support. A core component in LTE is the support of MIMO antenna deployments and MIMO related techniques. A current working assumption in LTE-Advanced, i.e. 3GPP Release-10, is the support of an eight-layer spatial multiplexing mode with possibly channel dependent precoding. The spatial multiplexing mode is aimed for high data rates in favourable channel conditions. An illustration of the spatial multiplexing mode is provided in **Figure 1**. Therein, the transmitted signal, represented by an information carrying symbol vector \mathbf{s} is multiplied by an $N_T \times r$ precoder matrix $\mathbf{W}_{N_T \times r}$, which serves to distribute the transmit energy in a subspace of the N_T -dimensional vector space, corresponding to N_T antenna ports. The precoder matrix is typically selected from a codebook of possible precoder matrices, and is typically indicated by means of a Precoder Matrix Indicator (PMI), which together with a Rank Indicator (RI) specifies a unique precoder matrix in the codebook. If the precoder matrix is confined to have orthonormal columns, then the design of the codebook of precoder matrices corresponds to a Grassmannian subspace packing problem. The r symbols in \mathbf{s} each are part of a symbol stream, a so-called layer, and r is referred to as the rank or transmission rank. In this way, spatial multiplexing is achieved since multiple symbols can be transmitted simultaneously over the same Resource Element (RE) or Time-Frequency Resource Element (TFRE). The number of symbols r is typically adapted to suit the current channel properties.

[0010] LTE uses Orthogonal Frequency Division Multiplexing (OFDM) in the downlink, and Discrete Fourier Transform (DFT) precoded OFDM in the uplink. The basic LTE physical resource can be seen as a time-frequency grid, as illustrated in **Figure 2**, where each time-frequency resource element (TFRE) corresponds to one subcarrier during one OFDM symbol interval, on a particular antenna port. The resource allocation in LTE is described in terms of resource blocks, where a resource block corresponds to one slot in the time domain and 12 contiguous 15 kHz subcarriers in the frequency domain. Two time-consecutive resource blocks represent a resource block pair, which corresponds to the time interval upon which scheduling operates.

[0011] The received $N_R \times 1$ vector \mathbf{y}_n for a certain resource element on subcarrier n or, worded differently, data RE number n or TFRE number n , assuming no inter-cell interference, is modeled by

$$\mathbf{y}_n = \mathbf{H}_n \mathbf{W}_{N_T \times r} \mathbf{s}_n + \mathbf{e}_n \quad (1)$$

where n denotes a transmission occasion in time and frequency, and \mathbf{e}_n is a noise and interference vector obtained as realizations of a random process. The precoder, or precoder matrix, for rank r , $\mathbf{W}_{N_T \times r}$ can be a wideband precoder, which may be constant over frequency, or frequency selective.

[0012] The precoder matrix is often chosen to match the characteristics of the $N_R \times N_T$ MIMO channel \mathbf{H}_n , also denoted channel matrix, resulting in so-called channel dependent precoding. When based on User Equipment (UE) feedback, this is also commonly referred to as closed-loop precoding and essentially strives for focusing the transmit energy into a subspace which is strong in the sense of conveying much of the transmitted energy to the UE or wireless device. In addition, the precoder matrix may also be selected to strive for orthogonalizing the channel, meaning that after proper linear equalization at the UE or wireless device, the inter-layer interference is reduced.

[0013] In closed-loop precoding, the UE or wireless device transmits, based on channel measurements in the forward link, i.e. the downlink, recommendations to the radio network node or base station of a suitable precoder to use. A single precoder that is supposed to cover a large bandwidth, so called wideband precoding, may be fed back. It may also be beneficial to match the frequency variations of the channel and instead feed back a frequency-selective precoding report, e.g. several precoders, one per subband. This is an example of the more general case of Channel State Information (CSI) feedback, which also encompasses feeding back other entities or information than precoders to assist the radio network node or base station in subsequent transmissions to the UE or wireless device. Such other information may include Channel Quality Indicators (CQIs) as well as Rank Indicator (RI).

[0014] In Release 8 and 9 of LTE the CSI feedback is given in terms of a transmission *rank indicator* (RI), a *precoder matrix indicator* (PMI), and *channel quality indicator(s)* (CQI). The CQI/RI/PMI report can be wideband or frequency selective depending on which reporting mode that is configured. This means that for CSI feedback LTE has adopted an

implicit CSI mechanism where a UE does not explicitly report e.g., the complex valued elements of a measured effective channel, but rather the UE recommends a transmission configuration for the measured effective channel. The recommended transmission configuration thus implicitly gives information about the underlying channel state.

5 **[0015]** The RI corresponds to a recommended number of streams that are to be spatially multiplexed and thus transmitted in parallel over the effective channel. The PMI identifies a recommended precoder (in a codebook) for the transmission, which relates to the spatial characteristics of the effective channel. The CQI represents a recommended transport block size, i.e., code rate. There is thus a relation between a CQI and a Signal to Interference and Noise Ratio (SINR) of the spatial stream(s) over which the transport block is transmitted. Therefore, noise and interference estimates are important quantities when estimating, for example, the CQI, which is typically estimated by the UE or wireless device and used for link adaptation and scheduling decisions at the radio network node or base station side.

10 **[0016]** The term \mathbf{e}_n in (1) represents noise and interference in a TFRE and is typically characterized in terms of second order statistics such as variance and correlation. The interference can be estimated in several ways. For example, estimates may be formed based on TFREs containing cell specific RS since s_n and $\mathbf{W}_{N_T \times P}$ are then known and \mathbf{H}_n is given by the channel estimator. The interference may then be estimated as the residual noise and interference on the TFREs of the Cell Specific Reference Signal (CRS), after the known CRS sequence has been pre-subtracted, i.e., after the CRS has been cancelled. An illustration of CRS, sometimes read out as Cell-specific Reference Symbols, for Rel-8 of LTE can be seen in **Figure 3**. It is further noted that the interference on TFREs with data that is scheduled for the UE in question can also be estimated as soon as the data symbols, \mathbf{s}_n are detected, since at that moment they can be regarded as known symbols. The latter interference can alternatively also be estimated based on second order statistics of the received signal and the signal intended for the UE of interest, thus possibly avoiding needing to decode the transmission before estimating the interference term. Alternatively the interference can be measured on TFREs where the desired signal, i.e. the signal intended for the UE of interest, is muted, so the received signal corresponds to interference only. This has the advantage that the interference measurement may be more accurate and the UE processing becomes trivial because no decoding or desired signal subtraction need to be performed.

25 **[0017]** In LTE Release-10, a new reference symbol sequence was introduced, the Channel State Information Reference Signal (CSI-RS), intended to be used for estimating channel state information. The CSI-RS provides several advantages over basing the CSI feedback on the CRS which were used, for that purpose, in previous releases. Firstly, the CSI-RS is not used for demodulation of the data signal, and thus does not require the same density. This means that the overhead of the CSI-RS is substantially less as compared to that of CRS. Secondly, CSI-RS provides a much more flexible means to configure CSI feedback measurements: For example, which CSI-RS resource to measure on can be configured in a UE specific manner. Moreover, antenna configurations larger than 4 antennas must resort to CSI-RS for channel measurements, since the CRS is only defined for at most 4 antennas.

30 **[0018]** A detailed example showing which resource elements within a resource block pair may potentially be occupied by UE-specific RS and CSI-RS is provided in Figure 4. In this example, the CSI-RS utilizes an orthogonal cover code of length two to overlay two antenna ports on two consecutive REs. As seen, many different CSI-RS patterns are available. For the case of 2 CSI-RS antenna ports, for example, there are 20 different patterns within a subframe. The corresponding number of patterns is 10 and 5 for 4 and 8 CSI-RS antenna ports, respectively.

35 **[0019]** A CSI-RS resource may be described as the pattern of resource elements on which a particular CSI-RS configuration is transmitted. One way of determining a CSI-RS resource is by a combination of the parameters "resourceConfig", "subframeConfig", and "antennaPortsCount", which may be configured by Radio Resource Control (RRC) signaling.

40 **[0020]** Based on a specified CSI-RS resource, that defines an effective channel for the data transmission, and an interference measurement configuration, e.g. a muted CSI-RS resource, the UE can estimate the effective channel and noise plus interference, and consequently also determine which rank, precoder and transport format to recommend that best match the particular effective channel.

45 **[0021]** Furthermore, in order to improve system performance, for example by improving the coverage of high data rates, improving the cell-edge throughput and/or increasing system throughput, Coordinated Multipoint (CoMP) transmission and/or reception may be used in a wireless communications system or radio access network. In particular, the goal is to distribute the user perceived performance more evenly in the network by taking control of the interference in the system, either by reducing the interference and/or by better prediction of the interference. To harvest the gains of introducing coordinated transmission or CoMP feedback it is essential that a radio network node or base station, e.g. an eNodeB, can accurately predict the performance of a UE or wireless device for various coordinated transmission hypotheses, in order to select an appropriate downlink assignment. To this end, accurate interference measurements at a terminal are a key element for CSI reporting targeting different transmission hypotheses. However, current state of the art solutions for interference measurements are constrained by current standards and/or limitations imposed by UE specific muting of data channels, making accurate interference measurements difficult, in particular for CoMP systems employing dynamic point selection and/or joint transmission, where the transmission point association to a UE varies dynamically in time.

55 **[0022]** Moreover, it is often beneficial for a scheduler in a radio network node or base station such as an eNodeB to

receive CSI reports that are based on a predictable and robust interference level. When a UE or wireless device measures interference caused by other data transmissions, the measured interference level will vary with the current traffic load and moreover will see rapid power variations due to the so called flash-light effect where dynamic precoding and/or beamforming in interfering points cause rapid and often unpredictable interference variations. For CSI reporting, such variations typically degrade the overall performance, since the measured interference often underestimates the interference seen at the subsequent data transmission allocation that is based on the CSI report. As a consequence, the radio network node or base station may have to reduce the data rate in the link adaptation to avoid excessive retransmissions due to uncertainties in the reported CQI.

[0023] To improve the possibilities for UEs to perform accurate interference measurements in a system zero-power (ZP) CSI-RS resources, also known as a muted CSI-RS have been introduced. The zero-power CSI-RS resources are configured just as regular CSI-RS resources, so that a UE knows that the data transmission is mapped around those resources. The intent of the zero-power CSI-RS resources is to enable the network to mute the transmission on the corresponding resources so as to boost the SINR of a corresponding non-zero power CSI-RS, possibly transmitted in a neighbor cell/transmission point. For Rel-11 of LTE, a special zero-power CSI-RS that a UE is mandated to use for measuring interference plus noise is under discussion. As the name indicates, a UE can assume that the TPs of interest are not transmitting on the muted CSI-RS resource and the received power can therefore be used as a measure of the interference plus noise level. For the purpose of improved interference measurements the agreement in LTE Release 11 is that the network will be able to configure a UE to measure interference on a particular Interference Measurement Resource (IMR) that identifies a particular set of TFREs that is to be used for a corresponding interference measurement.

[0024] However, reserving resources for specific purposes such as interference measurements reduces the resources available for data transmission. In some system configurations such reserved resources may give rise to a significant overhead, e.g. in the downlink when used to enable UEs to perform more reliable interference measurements.

[0025] Thus, there is a need for improving the efficiency in use of radio resources for reliably determining the interference that can be expected when receiving a signal over a communication channel from a radio access network.

SUMMARY

[0026] It is therefore an object of at least some embodiments of the present disclosure to reduce the overhead incurred by interference measurements in a wireless communications system.

[0027] According to a first embodiment of the present disclosure, this and other objects are achieved by a method in a transmitting node for enabling a receiving node to perform measurements on interference. The interference is caused by transmissions from at least one transmission point controlled by the transmitting node on receptions at the receiving node. The transmitting node and the receiving node are comprised in a wireless communications system. The transmitting node determines an interference measurement resource, IMR. The IMR comprises a set of Time-Frequency Resource Elements, TFREs, upon which the transmitting node is expected to transmit interference. The transmitting node transmits at least one interfering signal on the IMR as said interference. The at least one interfering signal comprises at least one of a desired signal and another signal. The desired signal is a signal that is expected to be decoded or coherently measured upon by the receiving node or another node served by the transmitting node. The another signal is a signal that is not expected to be decoded or coherently measured upon by any node served by the transmitting node. The desired signal is transmitted in place of the another signal as said at least one interfering signal on one or more TFREs of the IMR when the at least one transmission point is to transmit the desired signal to the receiving node or to the another node served by said transmitting node. The another signal is transmitted on TFREs of said IMR where no desired signal is transmitted and the another signal is muted on TFRE's of said IMR where the desired signal is transmitted.

[0028] According to a second embodiment of the present disclosure, this and other objects are achieved by a transmitting node for enabling a receiving node to perform measurements on interference. The transmitting node is configured to be connectable to at least one transmission point for communicating with the receiving node in the wireless communications system. Receptions at the receiving node may be susceptible to interference caused by transmissions from the at least one transmission point.

[0029] The transmitting node comprises processing circuitry. The processing circuitry is configured to determine an interference measurement resource, IMR. The IMR comprises a set of Time-Frequency Resource Elements, TFREs, upon which the transmitting node is expected to transmit interference. The processing circuitry is further configured to transmit, as said interference, at least one interfering signal on said IMR. The at least one interfering signal comprises at least one of a desired signal and another signal. The desired signal is a signal that is expected to be decoded or coherently measured upon by the receiving node or another node served by the transmitting node. The another signal is a signal that is not expected to be decoded or coherently measured upon by any node served by said transmitting node. The processing circuitry further configured to transmit the desired signal in place of the another signal as said at least one interfering signal on one or more TFREs of the IMR when the at least one transmission point is to transmit the desired signal to the receiving node or to the another node served by said transmitting node. The processing circuitry

is further configured to transmit the another signal on TFREs of said IMR where no desired signal is transmitted and to mute the another signal on TFRE's of said IMR where the desired signal is transmitted.

[0030] The above object is achieved since the transmission of a desired signal that may be transmitted in place of the another signal as the at least one interfering signal on an IMR enables the overhead, incurred by enabling more reliable interference measurements according to different desired interference compositions through the use of IMRs, to be reduced in that more radio resources are made available for data transmission and other signaling intended to be decoded or coherently measured upon by receiving nodes in the wireless communication system.

BRIEF DESCRIPTION OF THE DRAWINGS

[0031]

Figure 1 is a schematic block diagram illustrating the transmission structure of the precoded spatial multiplexing mode in LTE.

Figure 2 is a schematic diagram illustrating the LTE time-frequency resource grid.

Figure 3 is a schematic diagram illustrating cell-specific reference signals.

Figure 4 is a schematic diagram showing example layouts of reference signals.

Figure 5 is a schematic diagram illustrating a coordination cluster in a wireless network.

Figure 6 is a schematic diagram illustrating a coordination cluster in a wireless network.

Figure 7 is a schematic diagram illustrating a coordination cluster in a wireless network.

Figure 8a is a schematic diagram illustrating a scenario in a coordination cluster in a wireless network.

Figure 8b is a schematic diagram illustrating a scenario in a wireless network.

Figures 9a-9d are flow charts illustrating methods according to some embodiments.

Figure 10a is a block diagram illustrating a network node according to some embodiments.

Figure 10b is a block diagram illustrating details of a network node according to some embodiments.

Figure 11 a is a block diagram illustrating a wireless device according to some embodiments.

Figure 11b is a block diagram illustrating details of a wireless device according to some embodiments.

DETAILED DESCRIPTION

[0032] In this section, the invention will be illustrated in more detail by some exemplary embodiments. It should be noted that these embodiments are not mutually exclusive. Components from one embodiment may be tacitly assumed to be present in another embodiment and it will be understood by a person skilled in the art how those components may be used in the other exemplary embodiments.

[0033] It should be noted that although terminology from 3rd Generation Partnership Project (3GPP) LTE has been used in this disclosure to exemplify the invention, this should not be seen as limiting the scope of the invention to only the aforementioned system. Other wireless systems, including Wideband Code Division Multiple Access (WCDMA), Worldwide Interoperability for Microwave Access (WiMax), Ultra Mobile Broadband (UMB) and Global System for Mobile Communications (GSM) systems, may also benefit from exploiting the ideas covered within this disclosure.

[0034] Further, terminology such as eNodeB and UE should be considered as non-limiting and does in particular not imply a certain hierarchical relation between the two; in general the term "eNodeB" or base station could be considered as a first device, first node or transmitting node and the term "UE" could be considered as a second device, second node or receiving node, and these two devices communicate with each other over a radio channel that may be of various types, for example a multiple-input-multiple-output, "MIMO" channel. Herein, we also focus on wireless transmissions in the downlink, i.e. from the eNodeB to the UE, but the teachings of the embodiments described herein are equally

applicable in the uplink, i.e. from the UE to the eNodeB. Thus, in such embodiments the receiving node may be the eNodeB or base station and the transmitting node may be the UE.

[0035] Generally, in systems with uncoordinated scheduling of downlink transmissions, the UE may effectively measure interference observed from other TPs, or other cells, when computing a recommendation for interference level and use this in an upcoming data transmission. Such interference measurements are typically performed by analyzing the residual interference on CRS resources (after the UE subtracts the impact of the CRS signal).

[0036] However, in the present disclosure, the inventors have realized that in some situations, when it is important to obtain an accurate interference measurement on a transmission resource, such as Time-Frequency Resource Elements (TFREs) of a radio transmission interface in a wireless communication system, such measurements may not be easily obtainable. This may for example be the situation when traffic load is low in a system and it is desired, e.g. for scheduling purposes, to determine how interference on a specific transmission resource would impact scheduling of a data transmission to a receiving node such as a UE. Another situation when it may be difficult to obtain an adequate measured interference level is when the transmission scheme of an interfering transmission point varies rapidly in an on-off way, e.g. from subframe to subframe. In such situations, i.e. when the interference measurements will not adequately reflect the interference situation, the CSI reporting for link adaptation and/or Coordinated Multipoint (CoMP) transmission will become corrupted. The term CoMP is sometimes understood to imply that different transmission points have different geographical locations. However, for the purposes of embodiments of this disclosure, the coordinated transmission aspect is relevant also for situations where transmission points involved in coordinated transmission have the same geographical location. For example, multiple transmission points may in this context share the same physical antenna elements, but could use different virtualizations, e.g., different beam directions, as mentioned in the earlier discussion about Transmission points herein.

[0037] As mentioned above, interference measurement resources (IMRs), are adopted by the LTE standard to enable the network to better control the interference measurements in the UEs. By muting a particular set of transmission points on a corresponding IMR a UE will only measure the residual interference caused by any non-muted transmission point in the vicinity.

[0038] To enable appropriate interference measurements by a receiving node in the above exemplified and similar situations the inventors propose in this disclosure to have at least some transmission point, or virtualization thereof, whose interference is desired in a particular IMR, to actively transmit an interfering signal on the time-frequency resource elements of the particular IMR. The interfering signal may be a signal that is independent of any data transmission, control transmission or reference signal transmission to any node, e.g. UE or wireless device, or a desired signal, for example a data signal, that is to be transmitted from the transmission point and that can take the place of the interfering signal on at least some TFREs of the particular IMR where the signal that is independent of any data transmission, control transmission or reference signal transmission would otherwise be transmitted. The receiving node may be expected by the network to measure interference on the IMR. This expectation may be implicit, for example selecting an IMR where the receiving node is known to measure on interference or explicit, for example by instructing the receiving node to perform interference measurements on the IMR. The interfering signal that is independent of any data transmission, control transmission or reference signal transmission is independent in that it is not expected to be decoded or coherently measured upon by any node served by the transmitting node that controls the transmission point from which the interfering signal is transmitted. The desired signal is desired in that it is expected to be decoded or coherently measured upon by any nodes that may be configured to receive transmissions from the transmission point.

[0039] For the purpose of this disclosure an IMR is to be regarded in a wider context than currently adopted in 3GPP. For example, an IMR should be regarded only as a set of time frequency resource elements that a UE is expected, or will likely, estimate interference upon. For example, most implementations of Rel-8 to 10 LTE terminals measure interference on the TFREs associated with the cell specific reference signal (CRS), by first canceling the known CRS sequence. Hence, even though it is not mandated by the standard that a Rel 8-10 UE shall measure interference on the CRS resource elements, this is the de facto standard. Hence, in the following discussion also resource elements associated with a specific CRS configuration, i.e., a specific CRS shift and a specific number of CRS ports, are considered an IMR. Similarly, it should be understood that an IMR may also contain other desired signals intended for decoding or reference for a UE, in which case a UE is expected to cancel the impact of any such other desired signals, prior to performing the interference measurement. "Desired signal" in this context means a signal intended for reception by the receiving node, e.g. UE or wireless device. The interference measurement resource comprises a set of resource elements in which one or more signals assumed to be interfering with the desired signal are received. A reference signal resource comprises a set of resource elements in which one or more reference signals corresponding to a desired signal are received. In particular embodiments the reference signal resource is a CSI-RS resource. However, the reference signal (RS) resource may be any other type of RS resource which may be used to estimate a desired signal, e.g. a CRS resource.

[0040] To illustrate the teachings of this disclosure in more detail, some suggested embodiments will now be discussed in a coordinated transmission or CoMP scenario in a wireless communication system. However the reference to CoMP in the following discussion of this disclosure is not to be understood as limiting for the applicability of the teachings herein.

The teachings herein are equally applicable in any wireless communication system when there is a need to reliably determine the interference that can be expected when receiving a signal over a communication channel from a radio access network.

[0041] CoMP transmission and reception refers to a system where the transmission and/or reception at multiple, geographically separated antenna sites is coordinated in order to improve system performance. More specifically, CoMP refers to coordination of antenna arrays that have different geographical coverage areas. The coordination between points can either be distributed, by means of direct communication between the different sites, or by means of a central coordinating node. A further coordination possibility is a "floating cluster" where each transmission point is connected to, and coordinates, a certain set of neighbors (e.g. two neighbors). A set of points that perform coordinated transmission and/or reception is referred to as a CoMP coordination cluster, a coordination cluster, or simply as a cluster in the following.

[0042] CoMP operation targets many different deployments, including coordination between sites and sectors in cellular macro deployments, as well as different configurations of Heterogeneous deployments, where for instance a macro node coordinates the transmission with pico nodes within the macro coverage area. In Figures 5-7 examples of wireless communications network deployments with CoMP coordination clusters comprising three transmission points, denoted TP1, TP2 and TP3 are shown.

[0043] There are many different CoMP transmission schemes that are considered; for example:

Dynamic Point Blanking where multiple transmission points coordinate the transmission so that neighboring transmission points may mute the transmissions on the time-frequency resources (TFREs) that are allocated to UEs that experience significant interference.

Coordinated Beamforming where the TPs coordinate the transmissions in the spatial domain by beamforming the transmission power in such a way that the interference to UEs served by neighboring TPs is suppressed.

Dynamic Point Selection (DPS) where the data transmission to a UE may switch dynamically (in time and frequency) between different transmission points, so that the transmission points are fully utilized.

Joint Transmission where the signal to a UE is simultaneously transmitted from multiple TPs on the same time/frequency resource. The aim of joint transmission is to increase the received signal power and/or reduce the received interference, if the cooperating TPs otherwise would serve some other UEs without taking the UE subject to Joint Transmission (JT) into consideration.

[0044] A common denominator for the CoMP transmission schemes is that the network needs CSI information not only for the serving TP, but also for the channels linking the neighboring TPs to a terminal or UE. By, for example, configuring a unique CSI-RS resource per TP, a UE can resolve the effective channels for each TP by measurements on the corresponding CSI-RS. Note that the UE is likely unaware of the physical presence of a particular TP, it is only configured to measure on a particular CSI-RS resource, without knowing of any association between the CSI-RS resource and a TP.

[0045] Several different types of CoMP feedback are possible. Most alternatives are based on per CSI-RS resource feedback, possibly with CQI aggregation of multiple CSI-RS resources, and also possibly with some sort of co-phasing information between CSI-RS resources. The following is a non-exhaustive list of relevant alternatives (note that a combination of any of these alternatives is also possible):

Per CSI-RS resource feedback corresponds to separate reporting of channel state information (CSI) for each of a set of CSI-RS resources. Such a CSI report may, for example, comprise one or more of a *Precoder Matrix Indicator (PMI)*, *Rank Indicator (RI)*, and/or *Channel Quality Indicator (CQI)*, which represent a recommended configuration for a hypothetical downlink transmission over the same antennas used for the associated CSI-RS, or the RS used for the channel measurement. More generally, the recommended transmission should be mapped to physical antennas in the same way as the reference symbols used for the CSI channel measurement.

[0046] Typically there is a one-to-one mapping between a CSI-RS and a TP, in which case per CSI-RS resource feedback corresponds to per-TP feedback; that is, a separate PMI/RI/CQI is reported for each TP. Note that there could be interdependencies between the CSI reports; for example, they could be constrained to have the same RI. Interdependencies between CSI reports have many advantages, such as; reduced search space when the UE computes feedback, reduced feedback overhead, and in the case of reuse of RI there is a reduced need to perform rank override at the eNodeB.

[0047] The considered CSI-RS resources may be configured by the eNodeB as the CoMP Measurement Set. In the example shown in **Figure 5**, different measurement sets may be configured for wireless devices 540 and 550. For example, the measurement set for wireless device 540 may consist of CSI-RS resources transmitted by TP1 510 and TP2 520, since these points may be suitable for transmission to device 540. The measurement set for wireless device 550 may instead be configured to consist of CSI-RS resources transmitted by TP2 520 and TP3 530. The wireless

devices will report CSI information for the transmission points corresponding to their respective measurement sets, thereby enabling the network to e.g. select the most appropriate transmission point for each device.

[0048] *Aggregate feedback* corresponds to a CSI report for a channel that corresponds to an aggregation of multiple CSI-RS. For example, a joint PMI/RI/CQI can be recommended for a joint transmission over all antennas associated with the multiple CSI-RS.

[0049] A joint search may however be too computationally demanding for the UE, and a simplified form of aggregation is to evaluate an aggregate CQI which are combined with per CSI-RS resource PMIs, which should typically all be of the same rank corresponding to the aggregated CQI or CQIs. Such a scheme also has the advantage that the aggregated feedback may share much information with a per CSI-RS resource feedback. This is beneficial, because many CoMP transmission schemes require per CSI-RS resource feedback, and to enable eNodeB flexibility in dynamically selecting CoMP scheme, aggregated feedback would typically be transmitted in parallel with per CSI-RS resource feedback. To support coherent joint transmission, such per CSI-RS resource PMIs can be augmented with co-phasing information enabling the eNodeB to rotate the per CSI-RS resource PMIs so that the signals coherently combine at the receiver.

[0050] For efficient CoMP or coordinated transmission operation it is equally important to capture appropriate interference assumptions when determining the CQIs as it is to capture the appropriate received desired signal. Within a coordination cluster an eNodeB may to a large extent control which TPs that interfere a particular UE or wireless device in any particular TFRE. Hence, there will be multiple interference hypotheses depending on which TPs are transmitting data to other terminals, such as other UEs or wireless devices.

[0051] This means that, by controlling which TPs are transmitting data to other UEs or wireless devices, the network may control the interference seen by the particular UE or wireless device on an IMR. For example, by muting all TPs within a coordination cluster on the IMR, the the particular UE or wireless device will effectively measure the inter CoMP cluster interference. In the example shown in Figure 5, this would correspond to muting TP1 510, TP2 520 and TP3 530 in the TFREs associated with the IMR. However, it is essential that an eNodeB can accurately evaluate the performance of a UE given different CoMP transmission hypotheses - otherwise the dynamic coordination becomes meaningless. Thus the system need to be able to track/estimate also different intra-cluster interference levels corresponding to different transmission and blanking hypotheses. It has therefore been proposed to allow configuration of multiple distinct IMRs, wherein the network is responsible for realizing different relevant intra-cluster and/or inter-cluster interference hypotheses in the different IMRs, e.g., by muting the data transmissions accordingly on different transmission points, and that a UE should be able to perform multiple interference measurements, corresponding to different intra-cluster interference hypotheses, by means of configuring multiple IMRs; thus enabling CSI or CQI reporting for the different interference hypotheses. Hence, by associating a particular reported CSI or CQI with a particular IMR the relevant CSIs or CQIs can be made available to the network for effective scheduling.

[0052] The network would thus be responsible for configuring the transmissions so that the interference measured on the different IMRs corresponds to the desired interference hypotheses; that is, for each IMR a set of transmission points will be muted, and intra-cluster interference only from the remaining coordinated (and un-coordinated) transmission points will be present on the IMR. In the state-of-the-art solutions, the data transmission on a specific transmission point will thus not be muted (or similarly muted) on the IMRs where interference from the transmission point should be present (or absent).

[0053] However, in LTE, muting is configured by means of zero power CSI-RS, which is configured UE specifically. Thus, muting is a UE specific property, rather than a transmission point specific property. This difference does not have any practical implications when the UE is allocated and served by a single transmission point. However, in systems operating e.g. with dynamic point selection (DPS) and/or joint transmission (JT), where the transmission to a specific UE involves, or changes between, multiple transmission points, there will be a mismatch between a configured muting pattern specific to the UE, and one of the potentially different targeted muting patterns of two different involved transmission points. In the state-of-the-art solution, a UE, candidate for DPS/JT allocations, therefore would, typically, be configured to be muted on the union of the muting patterns for the two TPs. However, this will lead to an underestimation of the interference levels on the corresponding IMRs, since whenever the specific terminal is allocated the involved TPs will be muted also on IMRs where interference from the TP should be present.

[0054] Moreover, by realizing the different intra-cluster interference hypotheses by means of having an IMR excited by intra-cluster data transmissions the interference measurements will be impacted by the current traffic load in the system; that is, if there in a specific instance are no data for UEs that are candidates for transmissions from a particular TP, then there will be no data transmission that can collide with the IMR. Traditionally this is beneficial since the measured interference level will better reflect the typical, or expected, interference. However, when a coordinated cluster of transmission points are jointly (e.g., centrally) scheduled, the scheduler determines, and thus knows, the specific allocation on the coordinated transmission points-that is, the scheduler evaluates the two hypotheses where there is interference from a TP and when there is not. Hence, if the interference measurements including intra-cluster interference become biased by the load within the cluster, it will be more challenging for an eNodeB to accurately evaluate the performance of a UE for the hypothesis that there is interference present from a particular TP. This problem will be increasingly

pronounced the lower traffic load there is within the cluster.

[0055] Similarly, if dynamic point blanking is applied, interference measurements will be affected by rapidly varying on-off behavior of transmission points that are dynamically blanked, i.e. muted, on certain subframes. Since the UE is unaware of potential blanking on neighboring transmission points it cannot choose to exclude interference measurements on these time-frequency resources. The corresponding CSI report will consequently not represent the desired interference hypothesis.

[0056] Figure 5 illustrates an example wireless communications system 500 in which various embodiments of the invention may be implemented. The three transmission points 510, 520 and 530 form a CoMP coordination cluster. In the following, for purposes of illustration and not limitation, it will be assumed that the communications system 500 is an LTE system. Transmission points 510, 520 and 530 are remote radio units (RRU:s), controlled by eNodeB 560. In an alternative scenario (not shown), the transmission points could be controlled by separate eNodeBs. It should be appreciated that, generally speaking, each network node, e.g. eNodeB, may control one or more transmission points, which may either be physically co-located with the network node, or geographically distributed. In the scenario shown in Figure 5, it is assumed that the transmission points 510, 520 and 530 are connected to eNodeB 560, e.g. by optical cable or a point-to-point microwave connection. In the case where some or all of the transmission points forming the cluster are controlled by different eNodeBs, those eNodeBs would be assumed to be connected with each other e.g. by means of a transport network, to be able to exchange information for possible coordination of transmission and reception.

[0057] Consider for example a dynamic point blanking scheme, where there are at least two relevant interference hypotheses for a particular UE: In one interference hypothesis the UE sees no interference from the coordinated neighboring transmission point; and in the other hypothesis the UE sees interference from the neighboring point. To enable the network to effectively determine whether or not a TP should be muted, the UE can report two, or generally multiple, CSIs or CQIs corresponding to the different interference hypotheses. Continuing the example of Figure 5, assume that the wireless device 540 is configured to measure CSI from TP1 510. However, TP2 520 may potentially interfere with a transmission from TP1 510, depending on how the network schedules the transmission. Thus, the network may configure the device 540 for measuring the CSI-RS transmitted by TP1 for two interference hypotheses, the first one being that TP2 is silent, and the other one that TP2 is transmitting an interfering signal.

[0058] This situation is further illustrated in the example of Figure 8a. Therein, a UE or wireless device 540 has been configured with Interference Measurement Resources (IMRs) 815 comprising IMR1 850, IMR2 855, IMR3 860 and IMR4 862 by the network, e.g. in RRC signalling. Each IMR 850, 855, 860, 862 comprises at least one TFRE upon which the UE 540 is expected to perform measurements on interference. By configuring the corresponding resources in time t and frequency f 810 at transmission point TP1 510 and 805 at transmission point TP2 520 so that the transmission points TP1 510 and TP2 520 in various combinations transmit or does not transmit interfering signals on the different IMRs, the UE 540 is enabled to measure interference according to different interference hypotheses 875, 880, 885 and 887 as shown in table 870 in Figure 8a. From table 870 it can be seen that TP1 510 has been configured by the network to transmit an interfering signal on IMR2 840 and IMR3 845, and that from TP1 510 no interfering signal is transmitted on IMR1 835 and IMR4 847. Further, it can be seen from table 870 that TP2 520 has been configured by the network to transmit an interfering signal on IMR1 820 and IMR3 830, and that from TP2 520 no interfering signal is transmitted on IMR2 825 and IMR4 832. In this example, the interfering signals are signals that are not expected to be decoded or coherently measured upon by the UE 540 or any other node served by the transmitting node that controls the transmission point from which the interfering signal is transmitted. Further, in the example in Figure 8a, the measurements performed on IMR1, IMR2 and IMR3 correspond to different intra-cluster interference hypotheses H1 875, H2 880 and H3 885, whereas the measurements performed on IMR4 corresponds to inter-cluster interference hypothesis H4 887.

[0059] The interfering signal is not constrained by the configurations of specific UEs, but can be transmitted to match any interference composition of choice. For example, if all UEs within the cluster are configured to receive data transmissions that are muted on the union of the present IMRs, then there will be no data (or control) transmitted on any IMR. Thus, the interference measured on the IMRs may in the above example be unaffected by the intra-cluster data transmissions and the composition of the measured intra-cluster interference can be freely composed by the interfering signal(s).

[0060] In particular, an aspect is that interference from a particular transmission point (TP) is always present on all IMRs that the particular TP is expected to cause interference on. Otherwise the interference measurements on that IMR will not reflect the intended interference hypothesis. However, if the PDSCH of all UEs of a serving node are muted on all IMRs in a coordinated cluster this amounts to a significant overhead in the downlink.

[0061] The inventor has realized that in some situations it may be desired to increase the radio resources available for transmission of desired signals, such as data transmissions intended to be decoded by receiving nodes, or other desired signals intended to be coherently measured upon by receiving nodes, such as reference signals. Figure 8b illustrates a scenario where the interfering signal transmitted on IMR1 821 is a desired signal that is expected to be decoded or coherently measured upon by the receiving node 540 or another node 550 served by the transmitting node 560. The receiving node has been correspondingly configured to expect that a desired signal may be sent on the TFREs

of IMR1 851. This transmitted desired signal may further be used by receiving nodes in the wireless communication system, e.g. the receiving node 540 or the another node 550 for measuring interference according to interference hypothesis H1 875, as shown in table 871. As is further illustrated in Figure 8b, the interfering signal transmitted on a first part of the TFREs of IMR3 831, as indicated by horizontal stripes in the upper part of IMR3 831, is also a desired signal that is expected to be decoded or coherently measured upon by the receiving node 540 or another node 550 served by the transmitting node 560. The receiving node has been correspondingly configured to expect that a desired signal may be sent on the TFREs of IMR3 861. This transmitted desired signal may further be used by receiving nodes in the wireless communication system, e.g. the receiving node 540 or the another node 550 for measuring interference according to interference hypothesis H3 885, as shown in table 871, by measuring on a first part of IMR3, indicated as IMR3 upper in table 871. Interference according to interference hypothesis H3 885 may also be measured on a second part of IMR3, indicated as IMR3 lower in table 871. On the TFREs of this part of IMR3 the interfering signal transmitted by TP2 is another signal that is not expected to be decoded or coherently measured upon by the receiving node 540 or any other node served by the transmitting node 560 that controls the transmission point from which the interfering signal is transmitted. As this signal is not expected to be decoded or coherently measured upon, the receiving node 540 is configured not to expect any desired signal to be sent on these TFREs, as indicated by lower part of IMR3 861 being blank. Thus, IMR3 upper and IMR3 lower provides signals for measurement according to the same Interference hypothesis. The difference is only that for IMR3 upper TP2 sends a desired signal and TP1 sends the another signal whereas for IMR3 lower TP1 and TP2 both send the another signal. A receiving node, e.g. a UE that may switch between TP2 and TP1 needs to measure different interference hypotheses. However, a receiving node such as a UE that is only connected to TP 2 all the time need not perform such measurements, and can then be configured to expect that a desired signal such as a PDSCH data transmission may come on all the IMRs where TP2 is configured to transmit, i.e. in this case on IMR1 851 and IMR3 861.

[0062] It should be noted that the illustrations given in figures 8a and 8b are simplified to facilitate understanding. In practice, an IMR resource typically may comprise TFREs that are distributed over substantially the entire frequency bandwidth, for example with 4 TFREs in each resource block along the bandwidth. A data transmission to a receiving node is typically scheduled per resource block. When a desired signal, such as a data transmission, is transmitted on TFREs of an IMR as indicated in the example in Figure 8b, the transmission typically overlaps the TFREs in the resource block where the data transmission occurs. In Figure 8b only the TFREs where this overlap occurs are illustrated. According to this reasoning, IMR3 831 shows TFREs that belong two different resource blocks. Only the TFREs in the upper part of IMR3 belong to resource blocks where transmission of a desired signal occurs in such a way that the transmission overlaps the TFREs of the IMR3.

[0063] In short the illustrated embodiment of the invention involves dynamic alternation of a desired signal intended to be decoded or coherently measured upon by a receiving node such as a UE and another signal not intended to be decoded or coherently measured upon by any receiving node on an interference measurement resource (IMR) which the network intends to expose to a particular interference composition. Examples of desired signals may be data signals transmitted on the Physical Downlink Shared Channel (PDSCH). By letting the PDSCH from a particular TP be transmitted also in IMRs where interference should be present from the particular TP, the overhead of the PDSCH can be decreased, e.g. as compared to the case that only the above mentioned another signal is transmitted as interference signal on these particular IMRs, and by transmitting the another signal in the particular IMRs whenever/wherever a PDSCH is not present it is guaranteed that the correct interference composition is present on the particular IMR.

[0064] For UEs that are not candidates for transmissions involving other TPs than the serving TP it is sufficient to configure these UEs with a semi-static configuration of a muting pattern, e.g., a zero-power CSI-RS configuration, that covers the IMRs where the particular TP should be muted, whereas one or multiple IMRs where the TP should have interference present are not muted. Whenever the TP has a desired signal to transmit, such as a PDSCH transmission the data signal can take full use of all the resources also of the non-muted IMRs, and simultaneously cause the desired interference on this set of IMRs. However, when the TP does not have a desired signal such as a data signal (PDSCH) to transmit on resources defined by the IMRs that should have interference present, then a separate interference signal in form of the above mentioned another signal may be transmitted on those TFREs that are lacking the transmission of a desired signal. Thereby the TP can guarantee that interference is always present on a selected set of IMRs, but still utilize these IMRs for e.g. data transmissions when such are present.

[0065] In other words, by in this way enabling desired signals such as data transmissions to be scheduled so that they overlap TFREs of an IMR, the overhead incurred by enabling more reliable interference measurements according to different desired interference compositions through the use of IMRs may be substantially reduced in that more radio resources are made available for data transmission and other signaling intended to be decoded or coherently measured upon by receiving nodes in the wireless communication system. The embodiments of this disclosure achieve that the correct interference composition can be guaranteed to be present in an IMR while the PDSCH overhead is decreased, and thereby downlink throughput is increased

[0066] The above technique can also be used for UEs engaged in dynamic point selection and/or joint transmission

if the UE can be dynamically configured with a muting pattern, e.g. a ZP CSI-RS configuration, such that the muting pattern is always matched with the node/nodes from which the PDSCH transmission originates.

[0067] More generally, some embodiments provide a method in a transmitting node for enabling a receiving node to perform measurements on interference. The transmitting node enables the receiving node to perform measurements on interference by transmitting an interfering signal, as will now be described with reference to **Figures 5-7** and the flowcharts of **Figures 9a-9d**. As a particular example, the transmitting node may be the transmitting node, e.g. eNodeB, 560 in Figure 5 controlling TP1-TP3, which are transmission points or remote radio heads. In an alternative scenario, such as that shown in Figure 6, the transmitting node may be a transmitting node or an eNodeB with three sector antennas which correspond to transmission points TP1-TP3, forming a CoMP cluster 600 wherein a receiving node 540 is located. In yet another scenario, as shown in Figure 7, TP1-TP3 may form a CoMP cluster 700 wherein a receiving node 540 is located, and the transmitting node may either be the eNodeB controlling TP1 and TP3, or the eNodeB controlling TP2, and serving pico cell 720.

[0068] The interference is caused by transmissions from at least one transmission point 510, 520, 530 controlled by the transmitting node 560 on receptions at the receiving node 540. The transmitting and receiving nodes 560, 540 are comprised in a wireless communications system 500, 600, 700. The transmissions from different transmission points 510, 520, 530 may be coordinated in order to control interference and/or improve received signal quality in the wireless communications system 500, 600, 700. In some embodiments the wireless communications system may be configured to apply Coordinated Multipoint Transmission.

[0069] A first embodiment of the method is shown in Figure 9a, wherein:

In step 910 the transmitting node 560 determines an interference measurement resource, IMR. The IMR comprises a set of Time-Frequency Resource Elements, TFREs, upon which the transmitting node is expected to transmit interference. According to some embodiments, the IMR may comprise or be confined to TFREs upon which no signal that is expected to be decoded or coherently measured upon by any node 540, 550 served by the transmitting node 560 is pre-scribed to be transmitted. In other words according to these embodiments, a desired signal, that is expected to be decoded or coherently measured upon by at least one of the receiving nodes 540, 550 served by said transmitting node 560, is not pre-scribed, e.g. by the network or according to a standard, to be transmitted on the TFREs of the IMR. The receiving node 540 may in some embodiments be expected to measure interference on the IMR.

In step 930 the transmitting node 560 transmits, as said interference, at least one interfering signal on the IMR. The transmitted at least one interfering signal thereby causes the interference that the transmitting node 560 is expected to transmit on the IMR. The at least one interfering signal comprises at least one of a desired signal and another signal. The desired signal is expected to be decoded or coherently measured upon by the receiving node 540 or another node 550 served by said transmitting node 560. The desired signal may replace the another signal on one or more TFREs of the IMR when the desired signal is present. In other words, the desired signal may be transmitted in place of the another signal as said at least one interfering signal on one or more TFREs of the IMR when the desired signal is present at the at least one transmission point to be transmitted to the receiving node 540 or to the another node 550 served by said transmitting node 560. When the desired signal is not present at the at least one transmission point, or when no desired signal is present to be transmitted at the at least one transmission point, the another signal is transmitted by the at least one transmission point as said at least one interfering signal on the one or more TFREs of the IMR. The another signal is not expected to be decoded or coherently measured upon by any node 540, 550 served by the transmitting node 560. In some embodiments, the another signal is transmitted on TFREs of said IMR where the desired signal is not transmitted. Alternatively or additionally, the another signal may be transmitted on TFREs of said IMR where no desired signal is transmitted. The another signal is muted on TFRE's of said IMR where the desired signal is transmitted.

[0070] In an alternative, in step 910 the transmitting node 560 determines an interference measurement resource, IMR. The IMR comprises set of Time-Frequency Resource Elements, TFREs, upon which the transmitting node is expected to transmit interference. No signal that is expected to be decoded or coherently measured upon by any node 540, 550 served by the transmitting node 560 is pre-scribed to be transmitted on the TFREs. In other words, a desired signal, that is expected to be decoded or coherently measured upon by at least one of the receiving nodes 540, 550 served by said transmitting node 560, is not pre-scribed, e.g. by the network or according to a standard, to be transmitted on the TFREs of the IMR. The receiving node 540 may in some embodiments be expected to measure interference on the IMR.

[0071] According to the alternative, in step 930 the transmitting node 560 transmits at least one interfering signal on the IMR. The at least one interfering signal comprises at least one of a desired signal and another signal. The desired signal is expected to be decoded or coherently measured upon by the receiving node 540 or another node 550 served by said transmitting node 560. The another signal is not expected to be decoded or coherently measured upon by any

node 540, 550 served by the transmitting node 560. In some embodiments, the another signal is transmitted on TFREs of said IMR where the desired signal is not transmitted. Alternatively or additionally, the another signal may be transmitted on TFREs of said IMR where no desired signal is transmitted. The another signal is muted on TFRE's of said IMR where the desired signal is transmitted.

5 **[0072]** The transmitting node 560 may in at least some embodiments be configured to select, momentarily for a subframe to be transmitted, whether to transmit the desired signal or the another signal on the one or more TFREs of the IMR.

[0073] The desired signal may in at least some embodiments be a signal that is expected to be decoded by the receiving node 540 or another node 550 served by said transmitting node 560. In one example according to such
10 embodiments, the desired signal is a data signal transmitted on the Physical Downlink Shared Channel.

[0074] In some embodiments, the at least one transmission point 510, 520, 530 may comprise a composition of transmission points. The transmission of at least one interfering signal in step 930 may then comprise transmitting a respective interfering signal on the IMR from each transmission point in the composition of transmission points. The composition of transmission points may be selected so that it enables the receiving node 540 to measure interference applicable to at least one transmission hypothesis for which the receiving node 540 is to report Channel State Information, CSI, to the transmitting node 560. The selection of composition of transmission points may be made by the transmitting node 560. Alternatively in some embodiments, the selection may be made by a controlling node that coordinates transmissions from the at least one transmission point 510, 520, 530 with transmissions from at least one further transmission point controlled by a further transmitting node in the wireless communication system 500, 600, 700.

20 **[0075]** Figure 9b depicts an embodiment wherein the transmitting node 560 in addition to performing steps 910 and 930 as above instructs the receiving node 540, in a step 920, to measure interference on said IMR. Alternatively or additionally, the receiving node may be arranged to measure interference on said IMR without being explicitly instructed to do so by the transmitting node. In one particular embodiment, the receiving node may be preconfigured to measure interference on said IMR.

25 **[0076]** Figure 9c depicts an embodiment wherein the transmitting node 560 in addition to performing steps according to any of the embodiments of Figures 9a or 9b determines, in a step 925, an expected spatial signature of an intended data transmission to the receiving node 540 and, in a step 928, applies said expected spatial signature when transmitting said at least one interfering signal. The expected spatial signature may in some embodiments be determined based on respective buffer status and historic CSI reports of the receiving node 540 and at least one further receiving node 550 served by the transmitting node 560.

30 **[0077]** Figure 9d shows an embodiment where the interference measurements performed according to any of the embodiments of Figures 9a, 9b or 9c are used for link adaptation of a communication link between the transmitting node 560 and the receiving node 540. The link adaptation is performed as follows:

35 **[0078]** In step 940 the transmitting node 560 receives a Channel State Information, CSI, report from the receiving node 540. The CSI report is based at least in part on interference measurements performed by the receiving node 540 on the IMR.

[0079] In step 950 the transmitting node 560 transmits a data or control signal to the receiving node 540 using a resource allocation and/or link adaptation that is based, at least in part, on the CSI report.

40 **[0080]** The IMR may in any one of the embodiments presented above be configured to coincide with Time-Frequency Resource Elements, TFREs, of a Cell Specific Reference Signal, CRS, configuration. In some of these embodiments, no CRS is transmitted from the at least one transmission point 520, 530 on the TFREs of the CRS configuration. In these embodiments, CRS may be transmitted from a neighbouring transmission point 510 on the TFREs of the CRS configuration and transmissions from the at least one transmission point 520, 530 may be coordinated with transmissions from the neighbouring transmission point 510. In some embodiments Coordinated Multipoint Transmission may be applied to coordinate the transmissions.

45 **[0081]** Alternatively or additionally, the IMR may in any one of the embodiments presented above be configured to be covered by, overlap with or coincide with Time-Frequency Resource Elements, TFREs, of a Channel State Information-Reference Signal, CSI-RS, configuration applied for the receiving node 540. The impact of the CSI-RS may then need to be cancelled out by the receiving node 540 when performing the interference measurement.

50 **[0082]** Alternatively or additionally, the IMR may in any one of the embodiments presented above be configured to be covered by, overlap with or coincide with Time-Frequency Resource Elements, TFREs, of a zero power Channel State Information-Reference Signal, CSI-RS, configuration applied for the receiving node 540.

55 **[0083]** Furthermore, in any one of the embodiments presented above, a further desired signal expected to be decoded or coherently measured upon by any of the nodes 540, 550 served by the transmitting node 560 may be transmitted on at least one Time-Frequency Resource Element, TFRE, that is covered by, covers, overlaps with or coincides with the IMR, in addition to the transmitted at least one interfering signal. The impact of the further desired signal may then need to be cancelled out by the receiving node 540 when performing the interference measurement.

[0084] Furthermore, in any one of the embodiments presented above, the transmitted at least one interfering signal

may be an isotropic signal.

[0085] Furthermore, in any one of the embodiments presented above, the IMR determined in step 910 may be a subset of a set of TFREs upon which said receiving node 540 is configured not to expect data transmissions from any one of said at least one transmission point 510, 520, 530. In some of these embodiments, the set of TFREs may be a set of zero power Channel State Information-Reference Signal, CSI-RS, configurations.

[0086] Figures 10a-b illustrate devices configured to execute the methods described above in relation to Figure 9a-d.

[0087] Figure 10a illustrates a transmitting node 560, 1000 for enabling a receiving node 540 to perform measurements on interference. The transmitting node 560, 1000 enables the receiving node to perform measurements on interference by transmitting an interfering signal. The transmitting node 560, 1000 is configured to be connectable to radio circuitry 1010 comprised in at least one transmission point 510, 520, 530 for communicating with the receiving node 540 in the wireless communications system 500, 600, 700. Receptions at the receiving node 540 may be susceptible to interference caused by transmissions from the at least one transmission point 510, 520, 530.

[0088] The transmitting node 560, 1000 comprises processing circuitry 1020. The processing circuitry 1020 is configured to determine an interference measurement resource, IMR. The IMR comprises set of Time-Frequency Resource Elements, TFREs, upon which the transmitting node is expected to transmit interference. The receiving node 540 may in some embodiments be expected to measure interference on the IMR. The processing circuitry 1020 is further configured to transmit as said interference, via the at least one transmission point 510, 520, 530, at least one interfering signal on said IMR. The transmitted at least one interfering signal thereby causes the interference that the transmitting node 560, 1000 is expected to transmit on the IMR. The at least one interfering signal comprises at least one of a desired signal and another signal. The desired signal is expected to be decoded or coherently measured upon by the receiving node 540 or another node 550 served by said transmitting node 560, 1000. The transmitting node 560, 1000 may be configured to replace the another signal by the desired signal on one or more TFREs of the IMR when the desired signal is present. In other words, the transmitting node 560, 1000 may be configured to transmit the desired signal in place of the another signal as said at least one interfering signal on one or more TFREs of the IMR when the desired signal is present at the at least one transmission point 510, 520, 530 to be transmitted to the receiving node 540 or to the another node 550 served by said transmitting node 560. When the desired signal is not present at the at least one transmission point 510, 520, 530, or when no desired signal is present to be transmitted at the at least one transmission point 510, 520, 530, the another signal is transmitted by the at least one transmission point as said at least one interfering signal on the one or more TFREs of the IMR. The another signal is not expected to be decoded or coherently measured upon by any node 540, 550 served by said transmitting node 560, 1000. In some embodiments, the processing circuitry 1020 is configured to transmit the another signal on TFREs of said IMR where the desired signal is not transmitted. Alternatively or additionally, the processing circuitry 1020 may be configured to transmit the another signal on TFREs of said IMR where no desired signal is transmitted. The processing circuitry 1020 is configured to mute the another signal on TFRE's of said IMR where the desired signal is transmitted.

[0089] In an alternative, no signal that is expected to be decoded or coherently measured upon by any node 540, 550 served by the transmitting node 560, 1000 is pre-scribed to be transmitted on the TFREs of the IMR. In other words, a desired signal, that is expected to be decoded or coherently measured upon by at least one of the receiving nodes 540, 550 served by said transmitting node 560, is according to the alternative, not pre-scribed, e.g. by the network or according to a standard, to be transmitted on the TFREs of the IMR.

[0090] The transmitting node 560, 1000 may in at least some embodiments be configured to select, momentarily for a subframe to be transmitted, whether to transmit the desired signal or the another signal on one or more TFREs of the IMR.

[0091] The desired signal may in at least some embodiments be a signal that is expected to be decoded by the receiving node 540 or another node 550 served by said transmitting node 560. In one example according to such embodiments, the desired signal is a data signal transmitted on the Physical Downlink Shared Channel.

[0092] The processing circuitry 1020 may in some embodiments further be configured to receive, via the at least one transmission point 510, 520, 530, a Channel State Information, CSI, report from the receiving node 540. The CSI report may be based at least in part on interference measurements performed by the receiving node 540 on said IMR. Further, the processing circuitry 1020 may be configured to transmit, via the at least one transmission point 510, 520, 530, a data or control signal to said receiving node 540 using a resource allocation and/or link adaptation that is based, at least in part, on said CSI report.

[0093] The processing circuitry 1020 may in further embodiments further be configured to instruct, via the at least one transmission point 510, 520, 530, the receiving node 540 to measure interference on said IMR.

[0094] Figure 10b illustrates details of a possible implementation of processing circuitry 1020.

[0095] Figure 11 a shows a receiving node 1100 that may perform measurements on interference as enabled by the method performed in the transmitting node 1000.

[0096] Figure 11b illustrates details of a possible implementation of processing circuitry 1120 of the receiving node 1100.

[0097] In some embodiments, the method performed in an eNodeB involves

EP 2 850 752 B1

- 1) Determining for a first UE an Interference measurement resource for a specific Interference measurement.
- 2) Transmitting at least one interfering signal, over an effective channel on time/frequency resource elements associated with said specific Interference measurement resource, wherein said interfering signal is independent of data/control signalling
- 5 3) Receiving from said first UE a CSI report (that is expected to be) based, at least in part, on Interference measurements on said specific interference measurement resource
- 4) Transmitting a data or control signal, whose resource allocation and/or corresponding link adaptation is based, at least in part, on said CSI report.

10 **[0098]** Here, an effective channel includes the radio propagation channel as well as receive and transmit antenna gains. Moreover, an effective channel may involve multiple receive and/or transmit antennas, and can further include any virtualization of the antennas (i.e., linear transformations of signals to be transmitted on multiple transmit antennas). Hence a special case of step 2) above is to transmit the specific interfering signal from all antennas of a specific transmission point. Potentially, also a second Interfering signal (on the same IMR) may be transmitted also from the
15 antennas of a second transmission point, and so on.

[0099] A special embodiment, where the IMR is interpreted as a CRS resource, is in a heterogeneous deployment where at least one pico node shares the same cell ID as a macro node whose coverage area at least partially overlaps with the pico node's coverage area. With this particular deployment, the pico nodes and the macro will share the same CRS resource element positions (in fact also the same CRS sequence will be shared). Hence, with this configuration,
20 the data transmissions is always rate matched around (e.g., muted) the TFREs associated with the CRS, and thus the UEs served by the shared cell will not measure any interference from the nodes sharing the cell (presuming that they perform the interference measurement on the CRS positions). Hence by actively transmitting an Interfering signal from at least one of the transmission points (e.g., one of the pico nodes) on the CRS TFREs a Rel 8-10 LATE terminal will report CSI corresponding to present Interference from said at least one transmission point. This is particularly interesting
25 if the CRS is only transmitted from the macro node, whereas the pico nodes mute the CRS, and act purely as performance boosters for Rel-11 and beyond terminals, using transmission modes not relying on CRS. Hence, Release 8-10 terminals that connect to the macro will, due to the interfering signals transmitted from the pico nodes on the CRS positions, still measure relevant interference.

[0100] In another embodiment the Determining in step 1) comprises configuring, for example by means of radio resource control messages, said first UE to perform said specific interference measurement on an interference measurement resource selected by the eNodeB.
30

[0101] This will be the typical implementation for LTE Rel 11 terminals and beyond, where the IMR will be configurable.

[0102] In a further embodiment, the eNodeB configures also a second UE for data receptions that are muted on said specific interference measurement resource.

35 **[0103]** This embodiment reflects that by configuring muting for all terminals on one, or the union of multiple, IMR(s) then the network can take full control of the interference seen on the IMR(s) independently of the scheduling and the data transmissions.

[0104] In one embodiment, said interfering signal is an isotropic signal. In this context an isotropic signal refers to a signal that excites all dimensions of an effective channel.

40 **[0105]** By transmitting an isotropic interference signal (i.e., a spatially white, uncorrelated) signal no special bias to any spatial direction is imposed on the interference signal, which prevents the UE from making particular interference suppression assumptions of low rank interference in the CSI reporting (e.g., in the Interference suppression algorithms).

[0106] In another embodiment, the eNodeB, further determines an expected spatial signature of a subsequent data transmission, and applies said expected spatial signature on said interfering signal.

45 **[0107]** Such a spatial signature could be wideband or frequency selective. If the eNodeB can predict the spatial characteristics (e.g., typical beamforming or precoding directions) for subsequent data transmissions, it is beneficial to impose the same characteristics on the interfering signal, since this will allow a UE to better predict the actual interference suppression performance in the CSI reporting, and thus enable more accurate link adaptation in the eNodeB.

50 **[0108]** In one such embodiment, the eNodeB determines said expected spatial signature based on the buffer statuses of connected UEs and historic CSI reports from said connected UEs.

[0109] In a second such embodiment, the eNodeB excludes the non-primary (e.g. the non-strongest) transmission points participating in a joint transmission to a UE from the spatial signature.

[0110] This embodiment ensures that the transmit signal from a non-serving transmission point participating in a joint transmission is not accounted for as interference in the subsequent CSI report from the targeted UE.

55 **[0111]** In another embodiment, said interfering signal is constructed to have the same spatial signature as a current (or past) data and/or control transmission.

[0112] In one such embodiment, the interfering signal is muted on associated resource elements in RBs where there is no current data assignments to be transmitted over said effective channel.

[0113] This will effectively cause the UE to measure an interference corresponding to a data transmission, but without the restrictions of collisions with regular data.

[0114] Such embodiments can be beneficial when the scheduling of different transmission points are only partially coordinated; for example, when specific resource blocks (in time and/or frequency) are prioritized for transmissions from a specific node (but may be used by other nodes when the resource need is sufficiently high). In such limited coordination scenarios, there can typically not be a joint (central) scheduler that benefits from having on/off kind of interference estimates. Instead, it is typically more beneficial to let the interference measurement be biased by the current load in the system. For example, one IMR could be configured to capture the interference from data corresponding to prioritized resource blocks, and another IMR could be configured to capture the interference corresponding to the data interference on non-prioritized RB.

[0115] In another embodiment, said interfering signal is constructed to have the spatial signature that is a linear combination of the spatial signatures of current and past data and/or control transmission.

[0116] In one such embodiment, the interfering signal is muted on associated resource elements in RBs where there is no current data assignments to be transmitted over said effective channel.

[0117] The invention provides a solution to freely construct the interference composition on an IMR without any limitations imposed by UE specific muting configurations. Moreover, the interference measurements can be made to better reflect the performance when there is actual intra-cluster interference present without bias imposed by varying traffic load in the system.

[0118] This will translate to improved link adaptation and spectral efficiency in the wireless system.

[0119] When using the word "comprise" or "comprising" it shall be interpreted as non-limiting, i.e. meaning "consist at least of".

[0120] The present invention is not limited to the above described preferred embodiments. Various alternatives, modifications and equivalents may be used.

Claims

1. A method in a transmitting node (560) for enabling a receiving node (540) to perform measurements on interference caused by transmissions from at least one transmission point (510, 520, 530) controlled by the transmitting node (560) on receptions at the receiving node (540), the transmitting and receiving nodes (560, 540) being comprised in a wireless communications system (500, 600, 700), the method comprising:

determining (910) an interference measurement resource, IMR, comprising a set of Time-Frequency Resource Elements, TFREs, upon which the transmitting node is expected to transmit interference; and

transmitting (930) at least one interfering signal on said IMR as said interference, wherein the at least one interfering signal comprises a desired signal, that is expected to be decoded or coherently measured upon by the receiving node (540) or another node (550) served by said transmitting node (560),

the method **CHARACTERIZED IN that** the at least one interfering signal further comprises another signal, that is not expected to be decoded or coherently measured upon by any node (540, 550) served by said transmitting node (560), wherein the desired signal is transmitted in place of the another signal as said at least one interfering signal on one or more TFREs of the IMR when the at least one transmission point is to transmit the desired signal to the receiving node (540) or to the another node (550) served by said transmitting node (560) and wherein the another signal is transmitted on TFREs of said IMR where no desired signal is transmitted and wherein the another signal is muted on TFRE's of said IMR where the desired signal is transmitted.

2. The method of the preceding claim, further comprising selecting, for a subframe to be transmitted, whether to transmit the desired signal or the another signal on the one or more TFREs of the IMR.

3. The method of any of the preceding claims, wherein desired signal is expected to be decoded by the receiving node (540) or another node (550) served by said transmitting node (560).

4. The method of any of the preceding claims, wherein the desired signal is a data signal transmitted on the Physical Downlink Shared Channel.

5. The method of any of the preceding claims, wherein transmissions from different transmission points (510, 520, 530) are coordinated in order to control interference and/or improve received signal quality in the wireless communications system (500, 600, 700).

6. The method of any of the preceding claims, wherein the interference measurements are used for link adaptation of a communication link between the transmitting node (560) and the receiving node (540), the method comprising the further steps of:
- 5 *receiving* (940) a Channel State Information, CSI, report from the receiving node (540), wherein the CSI report is based at least in part on interference measurements performed by the receiving node (540) on said IMR; *transmitting* (950) a data or control signal to said receiving node (540) using a resource allocation and/or link adaptation that is based, at least in part, on said CSI report.
- 10 7. The method of any of the preceding claims, comprising the further step of: *instructing* (920) the receiving node (540) to measure interference on said IMR.
8. The method of any of the preceding claims, wherein the at least one transmission point (510, 520, 530) comprises a composition of transmission points and wherein transmitting the at least one interfering signal comprises transmitting a respective interfering signal on said IMR from each transmission point in said composition of transmission points.
- 15 9. The method of the preceding claim, wherein said composition of transmission points is selected so that it enables the receiving node (540) to measure interference applicable to at least one transmission hypothesis for which the receiving node (540) is to report Channel State Information, CSI, to the transmitting node (560).
- 20 10. The method of any of the claims 8-9, wherein said composition of transmission points is selected by the transmitting node (560).
- 25 11. The method of any of the claims 8-9, wherein said composition of transmission points is selected by a controlling node that coordinates transmissions from the at least one transmission point (510, 520, 530) with transmissions from at least one further transmission point controlled by a further transmitting node in said wireless communication system (500, 600, 700).
- 30 12. The method of any of the preceding claims, wherein the IMR coincides with Time-Frequency Resource Elements, TFREs, of a Cell Specific Reference Signal, CRS, configuration.
13. The method of the preceding claim, wherein no CRS is transmitted from the at least one transmission point (510, 520, 530) on the TFREs of the CRS configuration.
- 35 14. The method of the preceding claim, wherein CRS is transmitted from a neighbouring transmission point on the TFREs of the CRS configuration and wherein transmissions from the at least one transmission point (510, 520, 530) are coordinated with transmissions from the neighbouring transmission point.
- 40 15. The method of any of the claims 1-11, wherein the IMR is covered by Time-Frequency Resource Elements, TFREs, of a Channel State Information-Reference Signal, CSI-RS, configuration applied for the receiving node (540), and wherein the impact of the CSI-RS is to be cancelled out by the receiving node (540) when performing the interference measurement.
- 45 16. The method of any of the claims 1-11, wherein the IMR is covered by Time-Frequency Resource Elements, TFREs, of a zero power Channel State Information-Reference Signal, CSI-RS, configuration applied for the receiving node (540).
- 50 17. The method of any of the claims 1-11, wherein a further desired signal expected to be decoded or coherently measured upon by any of the nodes (540, 550) served by said transmitting node (560) is transmitted on at least one Time-Frequency Resource Element, TFRE, that coincides with the IMR, in addition to the transmitted at least one interfering signal, and wherein the impact of the further desired signal is to be cancelled out by the receiving node (540) when performing the interference measurement.
- 55 18. The method of any of the preceding claims, wherein the transmitted at least one interfering signal is an isotropic signal.
19. The method of any of the claims 1-17, further comprising the step of:

EP 2 850 752 B1

determining (925) an expected spatial signature of an intended data transmission to the receiving node (540);
applying (928) said expected spatial signature when transmitting said at least one interfering signal.

- 5 20. The method of the preceding claim, wherein said expected spatial signature is determined based on respective buffer status and historic CSI reports of the receiving node (540) and at least one further receiving node (550) served by the transmitting node (560).
- 10 21. The method of any of the preceding claims, wherein said determined IMR is a subset of a set of TFREs upon which said receiving node (540) is configured not to expect data transmissions from any one of said at least one transmission point (510, 520, 530).
- 15 22. The method of the preceding claim, wherein said set of TFREs is a set of zero power Channel State Information-Reference Signal, CSI-RS, configurations.
- 20 23. The method of any of the preceding claims, wherein said determined IMR applies for any receiving node (540, 550) served by the transmitting node (560).
- 25 24. A transmitting node (560, 1000) for enabling a receiving node (540) to perform measurements on interference, the transmitting node (560, 1000) being configured to be connectable to at least one transmission point (510, 520, 530) in a wireless communications system (500, 600, 700), wherein receptions at the receiving node are susceptible to interference caused by transmissions from the at least one transmission point (510, 520, 530), the transmitting node (560, 1000) comprising:
- 30 processing circuitry (1020) configured to determine an interference measurement resource, IMR, comprising a set of Time-Frequency Resource Elements, TFREs, upon which the transmitting node is expected to transmit interference, the processing circuitry (1020) further configured to transmit as said interference, via the at least one transmission point (510, 520, 530), at least one interfering signal on said IMR, wherein the at least one interfering signal comprises a desired signal, that is expected to be decoded or coherently measured upon by the receiving node (540) or another node (550) served by said transmitting node (560),
- 35 the transmitting node (560, 1000) **CHARACTERIZED IN that** the at least one interfering signal further comprises another signal, that is not expected to be decoded or coherently measured upon by any node (540, 550) served by said transmitting node (560, 1000), the processing circuitry (1020) further configured to transmit the desired signal in place of the another signal as said at least one interfering signal on one or more TFREs of the IMR when the at least one transmission point (510, 520, 530) is to transmit the desired signal to the receiving node (540) or to the another node (550) served by said transmitting node (560), the processing circuitry (1020) further configured to transmit the another signal on TFREs of said IMR where no desired signal is transmitted and to mute the another signal on TFRE's of said IMR where the desired signal is transmitted.
- 40 25. The transmitting node (560, 1000) of claim 24, wherein the transmitting node (560, 1000) is configured to use the interference measurements for link adaptation of a communication link between the transmitting node (560, 1000) and the receiving node (540), the processing circuitry (1020) further configured to:
- 45 receive, via the at least one transmission point (510, 520, 530), a Channel State Information, CSI, report from the receiving node (540), wherein the CSI report is based at least in part on interference measurements performed by the receiving node (540) on said IMR; and
- transmit, via the at least one transmission point (510, 520, 530), a data or control signal to said receiving node (540) using a resource allocation and/or link adaptation that is based, at least in part, on said CSI report.
- 50 26. The transmitting node (560, 1000) of any of the claims 24-25, wherein the processing circuitry (1020) is further configured to:
- instruct, via the at least one transmission point (510, 520, 530), the receiving node (540) to measure interference on said IMR.
- 55 27. The transmitting node (560, 1000) of any of the claims 24-26, wherein the at least one transmission point (560, 1000) comprises a composition of transmission points and wherein the processing circuitry (1020) is configured to transmit the at least one interfering signal by transmitting a respective interfering signal on said IMR via each transmission point in said composition of transmission points.

28. The transmitting node (560, 1000) of any of the claims 24-27, wherein the processing circuitry (1020) is configured to determine said IMR as a subset of a set of TFREs upon which said receiving node (540) is configured not to expect data transmissions from any one of said at least one transmission point (510, 520, 530).

5 29. The transmitting node (560, 1000) of the preceding claim, wherein said set of TFREs is a set of zero power Channel State Information-Reference Signal, CSI-RS, configurations.

10 **Patentansprüche**

1. Verfahren in einem Sendeknoten (560), um es einem Empfangsknoten (540) zu ermöglichen, Messungen von Interferenzen, die durch Übertragungen von mindestens einem Sendepunkt (510, 520, 530), der durch den Sendeknoten (560) gesteuert wird, verursacht werden, an Empfangssignalen im Empfangsknoten (540) auszuführen, wobei der Sende- und der Empfangsknoten (560, 540) in einem Drahtloskommunikationssystem (500, 600, 700) enthalten sind, wobei das Verfahren Folgendes umfasst:

Bestimmen (910) einer Interferenzmessungsressource (Interference Measurement Resource, IMR), die einen Satz Zeit-Frequenz-Ressourcenelemente (Time-Frequency Resource Elements, TFREs) umfasst, auf denen der Sendeknoten voraussichtlich Interferenzen senden wird; und

20 Senden (930) mindestens eines interferierenden Signals auf der IMR als die Interferenzen, wobei das mindestens eine interferierende Signal ein gewünschtes Signal umfasst, das voraussichtlich durch den Empfangsknoten (540) oder einen anderen Knoten (550), der durch den Sendeknoten (560) bedient wird, decodiert oder kohärent gemessen wird,

25 wobei das Verfahren **dadurch gekennzeichnet ist, dass** das mindestens eine interferierende Signal des Weiteren ein weiteres Signal umfasst, das voraussichtlich durch keinen der Knoten (540, 550), die durch den Sendeknoten (560) bedient werden, decodiert oder kohärent gemessen wird, wobei das gewünschte Signal anstelle des weiteren Signals als das mindestens eine interferierende Signal auf einem oder mehreren TFREs der IMR gesendet wird, wenn der mindestens eine Sendepunkt das gewünschte Signal an den Empfangsknoten (540) oder an den anderen Knoten (550), der durch den Sendeknoten (560) bedient wird, senden soll, und wobei das weitere Signal auf TFREs der IMR gesendet wird, wo kein gewünschtes Signal gesendet wird, und wobei das weitere Signal auf TFREs der IMR, wo das gewünschte Signal gesendet wird, stummgeschaltet wird.

30 2. Verfahren nach dem vorangehenden Anspruch, das des Weiteren Folgendes umfasst: Auswählen, für einen zu sendenden Teilframe, ob das gewünschte Signal oder das weitere Signal auf dem einen oder den mehreren TFREs der IMR gesendet werden soll.

35 3. Verfahren nach einem der vorangehenden Ansprüche, wobei das gewünschte Signal voraussichtlich durch den Empfangsknoten (540) oder einen anderen Knoten (550), der durch den Sendeknoten (560) bedient wird, decodiert wird.

40 4. Verfahren nach einem der vorangehenden Ansprüche, wobei das gewünschte Signal ein Datensignal ist, das auf dem Physical Downlink Shared Channel gesendet wird.

45 5. Verfahren nach einem der vorangehenden Ansprüche, wobei Übertragungen von verschiedenen Sendepunkten (510, 520, 530) koordiniert werden, um Interferenzen zu kontrollieren und/oder die Empfangssignalqualität in dem Drahtloskommunikationssystem (500, 600, 700) zu verbessern.

50 6. Verfahren nach einem der vorangehenden Ansprüche, wobei die Interferenzmessungen zur Linkadaptation eines Kommunikationslinks zwischen dem Sendeknoten (560) und dem Empfangsknoten (540) verwendet werden, wobei das Verfahren des Weiteren folgende Schritte umfasst:

Empfangen (940) eines Kanalzustandsinformations (Channel State Information, CSI)-Berichts von dem Empfangsknoten (540), wobei der CSI-Bericht mindestens zum Teil auf Interferenzmessungen basiert, die durch den Empfangsknoten (540) auf der IMR ausgeführt werden;

55 Senden (950) eines Daten- oder Steuersignals an den Empfangsknoten (540) unter Verwendung einer Ressourcenzuweisung und/oder Linkadaptation, die mindestens zum Teil auf dem CSI-Bericht basiert.

7. Verfahren nach einem der vorangehenden Ansprüche, das folgenden weiteren Schritt umfasst:

EP 2 850 752 B1

Anweisen (920) des Empfangsknotens (540), Interferenzen auf der IMR zu messen.

- 5 8. Verfahren nach einem der vorangehenden Ansprüche, wobei der mindestens eine Sendepunkt (510, 520, 530) eine Zusammensetzung von Sendepunkten umfasst, und wobei das Senden des mindestens einen interferierenden Signals das Senden eines jeweiligen interferierenden Signals auf der IMR von jedem Sendepunkt in der Zusammensetzung von Sendepunkten umfasst.
- 10 9. Verfahren nach dem vorangehenden Anspruch, wobei die Zusammensetzung von Sendepunkten so gewählt wird, dass der Empfangsknoten (540) in die Lage versetzt wird, Interferenzen zu messen, die auf mindestens eine Sendehypothese zutreffen, für die der Empfangsknoten (540) Kanalzustandsinformationen (Channel State Information, CSI) an den Sendeknoten (560) berichten soll.
- 15 10. Verfahren nach einem der Ansprüche 8-9, wobei die Zusammensetzung von Sendepunkten durch den Sendeknoten (560) gewählt wird.
- 20 11. Verfahren nach einem der Ansprüche 8-9, wobei die Zusammensetzung von Sendepunkten durch einen Steuerungsknoten gewählt wird, der Übertragungen von dem mindestens einen Sendepunkt (510, 520, 530) mit Übertragungen von mindestens einem weiteren Sendepunkt, der durch einen weiteren Sendeknoten in dem Drahtloskommunikationssystem (500, 600, 700) gesteuert wird, koordiniert.
- 25 12. Verfahren nach einem der vorangehenden Ansprüche, wobei die IMR mit Zeit-Frequenz-Ressourcenelementen (Time-Frequency Resource Elements, TFREs) einer Zellspezifischen-Referenzsignal (Cell Specific Reference Signal, CRS)-Konfiguration übereinstimmt.
- 30 13. Verfahren nach dem vorangehenden Anspruch, wobei kein CRS von dem mindestens einen Sendepunkt (510, 520, 530) auf den TFREs der CRS-Konfiguration gesendet wird.
- 35 14. Verfahren nach dem vorangehenden Anspruch, wobei ein CRS von einem benachbarten Sendepunkt in den TFREs der CRS-Konfiguration gesendet wird, und wobei Übertragungen von dem mindestens einen Sendepunkt (510, 520, 530) mit Übertragungen von dem benachbarten Sendepunkt koordiniert werden.
- 40 15. Verfahren nach einem der Ansprüche 1-11, wobei die IMR durch Zeit-Frequenz-Ressourcenelemente (Time-Frequency Resource Elements, TFREs) in einer Kanalzustandsinformationen-Referenzsignal (Channel State Information-Reference Signal, CSI-RS)-Konfiguration, die für den Empfangsknoten (540) angewendet wird, versorgt wird, und wobei die Auswirkung des CSI-RS durch den Empfangsknoten (540) beim Ausführen der Interferenzmessung neutralisiert werden soll.
- 45 16. Verfahren nach einem der Ansprüche 1-11, wobei die IMR durch Zeit-Frequenz-Ressourcenelemente (Time-Frequency Resource Elements, TFREs) einer Nullleistungs-Kanalzustandsinformationen-Referenzsignal (Channel State Information-Reference Signal, CSI-RS)-Konfiguration, die für den Empfangsknoten (540) angewendet wird, versorgt wird.
- 50 17. Verfahren nach einem der Ansprüche 1-11, wobei ein weiteres gewünschtes Signal, das voraussichtlich durch einen der Knoten (540, 550), die durch den Sendeknoten (560) bedient werden, decodiert oder kohärent gemessen wird, auf mindestens einem Zeit-Frequenz-Ressourcenelement (Time-Frequency Resource Element, TFRE), das mit der IMR übereinstimmt, zusätzlich zu dem gesendeten mindestens einen interferierenden Signal gesendet wird, und wobei die Auswirkung des weiteren gewünschten Signals durch den Empfangsknoten (540) beim Ausführen der Interferenzmessung neutralisiert werden soll.
- 55 18. Verfahren nach einem der vorangehenden Ansprüche, wobei das gesendete mindestens eine interferierende Signal ein isotropes Signal ist.
19. Verfahren nach einem der Ansprüche 1-17, das des Weiteren folgenden Schritt umfasst:
 - Bestimmen (925) einer erwarteten räumlichen Signatur einer beabsichtigten Datenübertragung an den Empfangsknoten (540);
 - Anwenden (928) der erwarteten räumlichen Signatur beim Senden des mindestens einen interferierenden Signals.

EP 2 850 752 B1

20. Verfahren nach dem vorangehenden Anspruch, wobei die erwartete räumliche Signatur auf der Basis jeweiliger Pufferstatus- und historischer CSI-Berichte des Empfangsknotens (540) und mindestens eines weiteren Empfangsknotens (550), der durch den Sendeknoten (560) bedient wird, bestimmt wird.
- 5 21. Verfahren nach einem der vorangehenden Ansprüche, wobei die bestimmte IMR eine Teilmenge eines Satzes TFREs ist, bezüglich derer der Empfangsknoten (540) dafür konfiguriert ist, keine Datenübertragungen von einem der mindestens einen Sendepunkte (510, 520, 530) zu erwarten.
- 10 22. Verfahren nach dem vorangehenden Anspruch, wobei der Satz TFREs ein Satz Nullleistungs-Kanalzustandsinformations-Referenzsignal (Channel State Information-Reference Signal, CSI-RS)-Konfigurationen ist.
- 15 23. Verfahren nach einem der vorangehenden Ansprüche, wobei die bestimmte IMR für jeden Empfangsknoten (540, 550) Anwendung findet, der durch den Sendeknoten (560) bedient wird.
- 20 24. Sendeknoten (560, 1000), der es einem Empfangsknoten (540) ermöglicht, Messungen von Interferenzen auszuführen, wobei der Sendeknoten (560, 1000) dafür konfiguriert ist, mit mindestens einem Sendepunkt (510, 520, 530) in einem Drahtloskommunikationssystem (500, 600, 700) verbunden werden zu können, wobei Empfangssignale im Empfangsknoten für Interferenzen anfällig sind, die durch Übertragungen von dem mindestens einen Sendepunkt (510, 520, 530) verursacht werden, wobei der Sendeknoten (560, 1000) Folgendes umfasst:
- 25 eine Verarbeitungsschaltanordnung (1020), die dafür konfiguriert ist, eine Interferenzmessungsressource (Interference Measurement Resource, IMR) zu bestimmen, die einen Satz Zeit-Frequenz-Ressourcenelemente (Time-Frequency Resource Elements, TFREs) umfasst, auf denen der Sendeknoten voraussichtlich Interferenzen senden wird, wobei die Verarbeitungsschaltanordnung (1020) des Weiteren dafür konfiguriert ist, über den mindestens einen Sendepunkt (510, 520, 530) mindestens ein interferierendes Signal auf der IMR als die
- 30 Interferenzen zu senden, wobei das mindestens eine interferierende Signal ein gewünschtes Signal umfasst, das voraussichtlich durch den Empfangsknoten (540) oder einen anderen Knoten (550), der durch den Sendeknoten (560) bedient wird, decodiert oder kohärent gemessen wird, wobei der Sendeknoten (560, 1000) **dadurch gekennzeichnet ist, dass** das mindestens eine interferierende Signal des Weiteren ein weiteres Signal umfasst, das voraussichtlich durch keinen der Knoten (540, 550), die durch den Sendeknoten (560, 1000) bedient werden, decodiert oder kohärent gemessen wird, wobei die Verarbeitungsschaltanordnung (1020) des Weiteren dafür konfiguriert ist, das gewünschte Signal anstelle des weiteren Signals als das mindestens eine interferierende Signal auf einem oder mehreren TFREs der IMR zu
- 35 senden, wenn der mindestens eine Sendepunkt (510, 520, 530) das gewünschte Signal an den Empfangsknoten (540) oder an den anderen Knoten (550), der durch den Sendeknoten (560) bedient wird, senden soll, wobei die Verarbeitungsschaltanordnung (1020) des Weiteren dafür konfiguriert ist, das weitere Signal auf TFREs der IMR, wo kein gewünschtes Signal gesendet wird, zu senden und das weitere Signal auf TFREs der IMR, wo das gewünschte Signal gesendet wird, stummzuschalten.
- 40 25. Sendeknoten (560, 1000) nach Anspruch 24, wobei der Sendeknoten (560, 1000) dafür konfiguriert ist, die Interferenzmessungen für die Linkadaptation eines Kommunikationslinks zwischen dem Sendeknoten (560, 1000) und dem Empfangsknoten (540) zu verwenden, wobei die Verarbeitungsschaltanordnung (1020) des Weiteren für Folgendes konfiguriert ist:
- 45 Empfangen, über den mindestens einen Sendepunkt (510, 520, 530), eines Kanalzustandsinformations (Channel State Information, CSI)-Berichts von dem Empfangsknoten (540), wobei der CSI-Bericht mindestens zum Teil auf Interferenzmessungen basiert, die durch den Empfangsknoten (540) auf der IMR ausgeführt werden; und Senden, über den mindestens einen Sendepunkt (510, 520, 530), eines Daten- oder Steuersignals an den
- 50 Empfangsknoten (540) unter Verwendung einer Ressourcenzuweisung und/oder Linkadaptation, die mindestens zum Teil auf dem CSI-Bericht basiert.
26. Sendeknoten (560, 1000) nach einem der Ansprüche 24-25, wobei die Verarbeitungsschaltanordnung (1020) des Weiteren für Folgendes konfiguriert ist:
- 55 Anweisen des Empfangsknoten (540) über den mindestens einen Sendepunkt (510, 520, 530), Interferenzen auf der IMR zu messen.
27. Sendeknoten (560, 1000) nach einem der Ansprüche 24-26, wobei der mindestens eine Sendepunkt (560, 1000)

EP 2 850 752 B1

eine Zusammensetzung von Sendepunkten umfasst, und wobei die Verarbeitungsschaltanordnung (1020) dafür konfiguriert ist, das mindestens eine interferierende Signal durch Senden eines jeweiligen interferierenden Signals auf der IMR über jeden Sendepunkt in der Zusammensetzung von Sendepunkten zu senden.

- 5 **28.** Sendeknoten (560, 1000) nach einem der Ansprüche 24-27, wobei die Verarbeitungsschaltanordnung (1020) dafür konfiguriert ist, die IMR als eine Teilmenge eines Satzes TFREs zu bestimmen, bezüglich derer der Empfangsknoten (540) dafür konfiguriert ist, keine Datenübertragungen von einem der mindestens einen Sendepunkte (510, 520, 530) zu erwarten.
- 10 **29.** Sendeknoten (560, 1000) des vorausgehenden Anspruchs, wobei der Satz TFREs ein Satz Nulleistungs-Kanalzustandsinformations-Referenzsignal (Channel State Information-Reference Signal, CSI-RS)-Konfigurationen ist.

Revendications

- 15 **1.** Procédé, dans un noeud d'émission (560), pour permettre à un noeud de réception (540) d'effectuer des mesures sur une interférence provoquée par des émissions d'au moins un point d'émission (510, 520, 530) commandé par le noeud d'émission (560) sur des réceptions au noeud de réception (540), les noeuds d'émission et de réception (560, 540) étant compris dans un système de communication sans fil (500, 600, 700), le procédé comprenant :

20 la détermination (910) d'une ressource de mesure d'interférence, IMR, comprenant un ensemble d'éléments de ressources de temps-fréquence, TFRE, sur lequel le noeud d'émission est censé émettre une interférence ; et l'émission (930) d'au moins un signal d'interférence sur ladite IMR en tant que ladite interférence, dans lequel l'au moins un signal d'interférence comprend un signal souhaité, qui est censé être décodé ou mesuré de manière cohérente par le noeud de réception (540) ou un autre noeud (550) desservi par ledit noeud d'émission (560),

25 le procédé étant **caractérisé en ce que** l'au moins un signal d'interférence comprend en outre un autre signal, qui n'est pas censé être décodé ou mesuré de manière cohérente par un noeud (540, 550) desservi par ledit noeud d'émission (560), dans lequel le signal souhaité est émis à la place de l'autre signal en tant que ledit au moins un signal d'interférence sur un ou plusieurs TFRE de l'IMR lorsque l'au moins un point d'émission doit émettre le signal souhaité au noeud de réception (540) ou à l'autre noeud (550) desservi par ledit noeud d'émission (560) et dans lequel l'autre signal est émis sur des TFRE de ladite IMR lorsqu'aucun signal souhaité n'est émis et dans lequel l'autre signal est coupé sur les TFRE de ladite IMR lorsque le signal souhaité est émis.

- 35 **2.** Procédé selon la revendication précédente, comprenant en outre la sélection, pour une sous-trame à émettre, s'il faut émettre le signal souhaité ou l'autre signal sur l'un ou plusieurs TFRE de l'IMR.
3. Procédé selon l'une quelconque des revendications précédentes, dans lequel le signal souhaité est censé être décodé par le noeud de réception (540) ou un autre noeud (550) desservi par ledit noeud d'émission (560).
- 40 **4.** Procédé selon l'une quelconque des revendications précédentes, dans lequel le signal souhaité est un signal de données émis sur le canal partagé de liaison descendante physique.
5. Procédé selon l'une quelconque des revendications précédentes, dans lequel des émissions de différents points d'émission (510, 520, 530) sont coordonnées afin de réguler l'interférence et/ou d'améliorer la qualité du signal reçu dans le système de communication sans fil (500, 600, 700).
- 45 **6.** Procédé selon l'une quelconque des revendications précédentes, dans lequel les mesures d'interférence sont utilisées pour effectuer une adaptation de liaison d'une liaison de communication entre le noeud d'émission (560) et le noeud de réception (540), le procédé comprenant en outre les étapes de :

50 la réception (940) d'un rapport d'informations d'état de canal, CSI, en provenance du noeud de réception (540), dans lequel le rapport de CSI est basé au moins en partie sur des mesures d'interférence effectuées par le noeud de réception (540) sur ladite IMR ;

55 l'émission (950) d'un signal de données ou de commande au dit noeud de réception (540) en utilisant une allocation de ressources et/ou une adaptation de liaison qui sont basées au moins en partie sur ledit rapport de CSI.

EP 2 850 752 B1

7. Procédé selon l'une quelconque des revendications précédentes, comprenant en outre l'étape de :

l'instruction (920) au noeud de réception (540) de mesurer une interférence sur ladite IMR.

- 5 8. Procédé selon l'une quelconque des revendications précédentes, dans lequel l'au moins un point d'émission (510, 520, 530) comprend une composition de points d'émission et dans lequel l'émission de l'au moins un signal d'interférence comprend l'émission d'un signal d'interférence respectif sur ladite IMR à partir de chaque point d'émission dans ladite composition de points d'émission.
- 10 9. Procédé selon la revendication précédente, dans lequel ladite composition de points d'émission est sélectionnée de manière à permettre au noeud de réception (540) de mesurer une interférence applicable à l'au moins une hypothèse d'émission dans laquelle le noeud de réception (540) doit rapporter des informations d'état de canal, CSI, au noeud d'émission (560) .
- 15 10. Procédé selon l'une quelconque des revendications 8 et 9, dans lequel ladite composition de points d'émission est sélectionnée par le noeud d'émission (560).
11. Procédé selon l'une quelconque des revendications 8 et 9, dans lequel ladite composition de points d'émission est sélectionnée par un noeud de commande qui coordonne des émissions de l'au moins un point d'émission (510, 20 520, 530) avec des émissions de l'au moins un autre point d'émission commandé par un autre noeud d'émission dans ledit système de communication sans fil (500, 600, 700).
12. Procédé selon l'une quelconque des revendications précédentes, dans lequel l'IMR coïncide avec des éléments de ressources de temps-fréquence, TFRE, d'une configuration de signal de référence spécifique à la cellule, CRS. 25
13. Procédé selon la revendication précédente, dans lequel aucun CRS n'est émis de l'au moins un point d'émission (510, 520, 530) sur les TFRE de la configuration de CRS.
14. Procédé selon la revendication précédente, dans lequel le CRS est émis depuis un point d'émission voisin sur les TFRE de la configuration de CRS et dans lequel les émissions de l'au moins un point d'émission (510, 520, 530) sont coordonnées avec des émissions du point d'émission voisin. 30
15. Procédé selon l'une quelconque des revendications 1 à 11, dans lequel l'IMR est couverte par des éléments de ressources de temps-fréquence, TFRE, d'une configuration de signal de référence d'informations d'état de canal, CSI-RS, appliquée au noeud de réception (540), et dans lequel l'impact de la CSI-RS doit être annulé par le noeud de réception (540) lors de l'exécution de la mesure d'interférence. 35
16. Procédé selon l'une quelconque des revendications 1 à 11, dans lequel l'IMR est couverte par des éléments de ressources de temps-fréquence, TFRE, d'une configuration de signal de référence d'informations d'état de canal, CSI-RS, de puissance nulle appliquée au noeud de réception (540). 40
17. Procédé selon l'une quelconque des revendications 1 à 11, dans lequel un autre signal souhaité censé être décodé ou mesuré de manière cohérente par l'un quelconque des noeuds (540, 550) desservis par ledit noeud d'émission (560) est émis sur au moins un élément de ressources de temps-fréquence, TFRE, qui coïncide avec l'IMR, en plus de l'au moins un signal d'interférence émis, et dans lequel l'impact de l'autre signal souhaité est d'être annulé par le noeud de réception (540) lors de l'exécution de la mesure d'interférence. 45
18. Procédé selon l'une quelconque des revendications précédentes, dans lequel l'au moins un signal d'interférence émis est un signal isotrope. 50
19. Procédé selon l'une quelconque des revendications 1 à 17, comprenant en outre les étapes de :
- la détermination (925) d'une signature spatiale prévue d'une émission de données prévue au noeud de réception (540) ;
- 55 l'application (928) de ladite signature spatiale prévue lors de l'émission dudit au moins un signal d'interférence.
20. Procédé selon la revendication précédente, dans lequel ladite signature spatiale prévue est déterminée sur la base d'un statut de mémoire tampon respectif et de rapports de CSI historiques du noeud de réception (540) et d'au

moins un autre noeud de réception (550) desservi par le noeud d'émission (560).

21. Procédé selon l'une quelconque des revendications précédentes, dans lequel ladite IMR déterminée est un sous-ensemble d'un ensemble de TFRE sur lequel ledit noeud de réception (540) est configuré pour ne pas attendre d'émissions de données de l'un quelconque dudit au moins un point d'émission (510, 520, 530).

22. Procédé selon la revendication précédente, dans lequel ledit ensemble de TFRE est un ensemble de configurations de signal de référence d'informations d'état de canal, CSI-RS, de puissance nulle.

23. Procédé selon l'une quelconque des revendications précédentes, dans lequel ladite IMR déterminée s'applique pour n'importe quel noeud de réception (540, 550) desservi par le noeud d'émission (560).

24. Noeud d'émission (560, 1000) pour permettre à un noeud de réception (540) d'effectuer des mesures sur une interférence, le noeud émission (560, 1000) étant configuré pour pouvoir être relié à au moins un point d'émission (510, 520, 530) dans un système de communication sans fil (500, 600, 700), dans lequel des réceptions au noeud de réception sont susceptibles de subir une interférence provoquée par des émissions de l'au moins un point d'émission (510, 520, 530), le noeud d'émission (560, 1000) comprenant :

une circuiterie de traitement (1020) configurée pour effectuer la détermination d'une ressource de mesure d'interférence, IMR, comprenant un ensemble d'éléments de ressources de temps-fréquence, TFRE, sur lequel le noeud d'émission est censé émettre une interférence, la circuiterie de traitement (1020) étant en outre configurée pour effectuer l'émission d'au moins un signal d'interférence sur ladite IMR en tant que ladite interférence, par l'intermédiaire de l'au moins un point d'émission (510, 520, 530), dans lequel l'au moins un signal d'interférence comprend un signal souhaité, qui est censé être décodé ou mesuré de manière cohérente par le noeud de réception (540) ou un autre noeud (550) desservi par ledit noeud d'émission (560),

le noeud d'émission (560, 1000) étant **caractérisé en ce que** l'au moins un signal d'interférence comprend en outre un autre signal, qui n'est pas censé être décodé ou mesuré de manière cohérente par un noeud (540, 550) desservi par ledit noeud d'émission (560, 1000), la circuiterie de traitement (1020) étant en outre configurée pour effectuer l'émission du signal souhaité à la place de l'autre signal en tant que ledit au moins un signal d'interférence sur un ou plusieurs TFRE de l'IMR lorsque l'au moins un point d'émission (510, 520, 530) doit émettre le signal souhaité au noeud de réception (540) ou à l'autre noeud (550) desservi par ledit noeud d'émission (560), la circuiterie de traitement (1020) étant en outre configurée pour émettre l'autre signal sur des TFRE de ladite IMR lorsqu'aucun signal souhaité n'est émis et couper l'autre signal sur les TFRE de ladite IMR lorsque le signal souhaité est émis.

25. Noeud d'émission (560, 1000) selon la revendication 24, dans lequel le noeud d'émission (560, 1000) est configuré pour utiliser les mesures d'interférence pour effectuer une adaptation de liaison d'une liaison de communication entre le noeud d'émission (560, 1000) et le noeud de réception (540), la circuiterie de traitement (1020) étant en outre configurée pour effectuer :

la réception, par l'intermédiaire de l'au moins un point d'émission (510, 520, 530), d'un rapport d'informations d'état de canal, CSI, en provenance du noeud de réception (540), dans lequel le rapport de CSI est basé au moins en partie sur des mesures d'interférence effectuées par le noeud de réception (540) sur ladite IMR ; et l'émission, par l'intermédiaire de l'au moins un point d'émission (510, 520, 530), d'un signal de données ou de commande au dit noeud de réception (540) en utilisant une allocation de ressources et/ou une adaptation de liaison qui sont basées au moins en partie sur ledit rapport de CSI.

26. Noeud d'émission (560, 1000) selon l'une quelconque des revendications 24 et 25, dans lequel la circuiterie de traitement (1020) est en outre configurée pour effectuer :

l'instruction, par l'intermédiaire de l'au moins un point d'émission (510, 520, 530), au noeud de réception (540) de mesurer une interférence sur ladite IMR.

27. Noeud d'émission (560, 1000) selon l'une quelconque des revendications 24 à 26, dans lequel l'au moins un point d'émission (560, 1000) comprend une composition de points d'émission et dans lequel la circuiterie de traitement (1020) est configurée pour effectuer l'émission de l'au moins un signal d'interférence par l'émission d'un signal d'interférence respectif sur ladite IMR, par l'intermédiaire de chaque point d'émission dans ladite composition de points d'émission.

EP 2 850 752 B1

28. Noeud d'émission (560, 1000) selon l'une quelconque des revendications 24 à 27, dans lequel la circuiterie de traitement (1020) est configurée pour effectuer la détermination de ladite IMR en tant qu'un sous-ensemble d'un ensemble de TFRE sur lequel ledit noeud de réception (540) est configuré pour ne pas attendre d'émissions de données de l'un quelconque dudit au moins un point d'émission (510, 520, 530).

5

29. Noeud d'émission (560, 1000) selon la revendication précédente, dans lequel ledit ensemble de TFRE est un ensemble de configurations de signal de référence d'informations d'état de canal, CSI-RS, de puissance nulle.

10

15

20

25

30

35

40

45

50

55

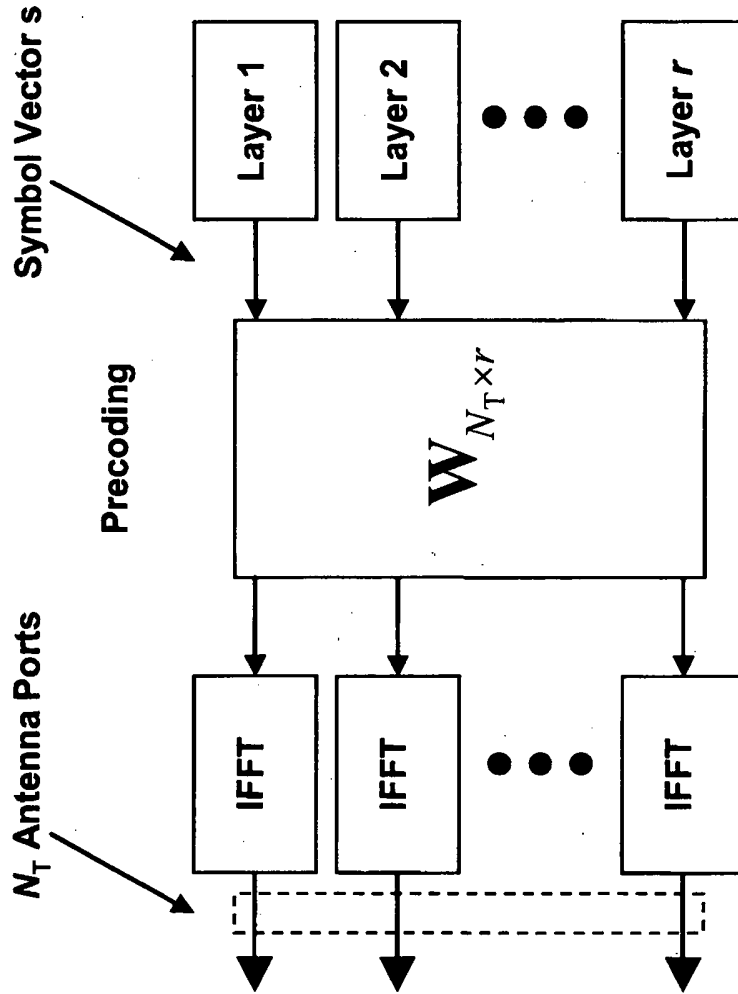

Figure 1

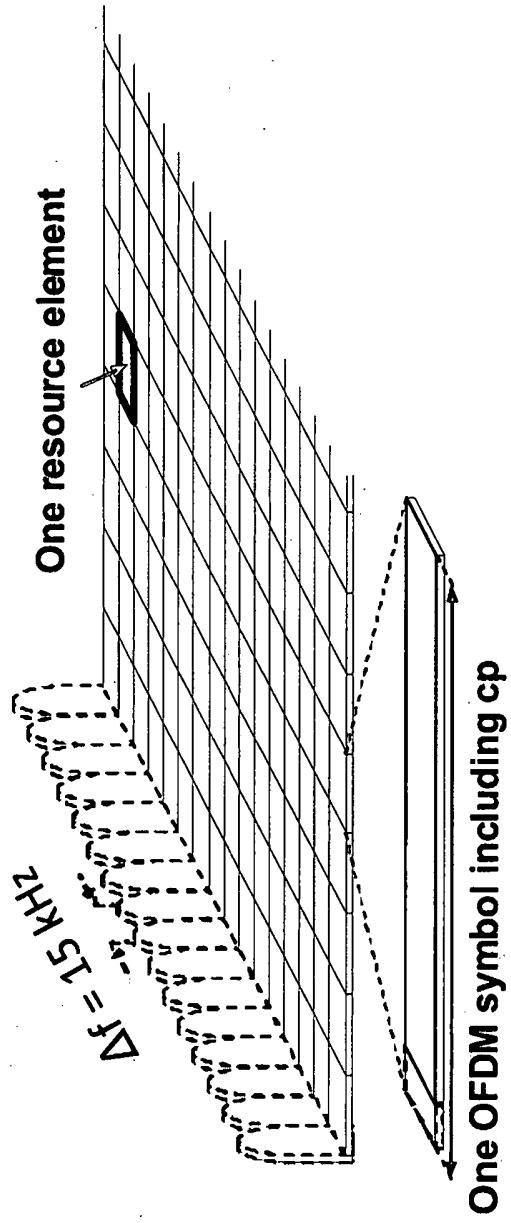

Figure 2

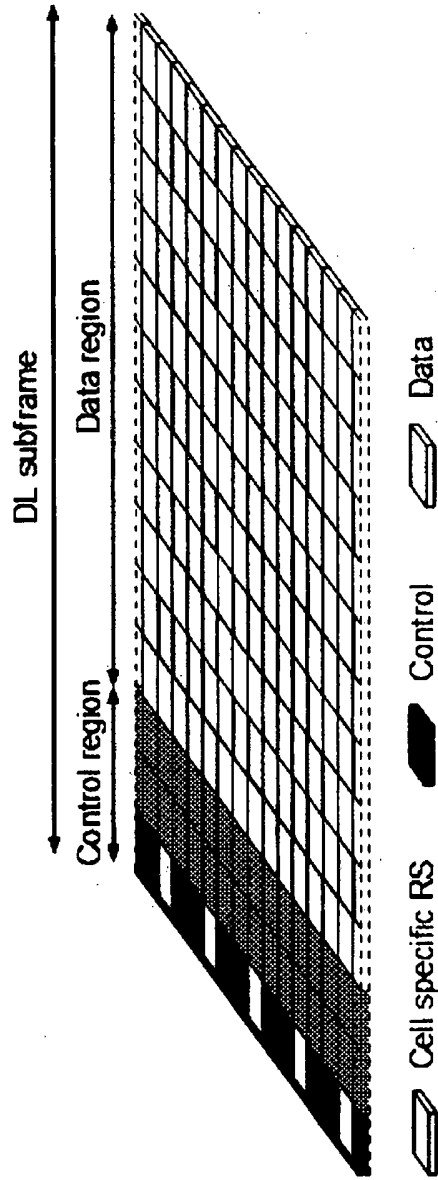

Figure 3

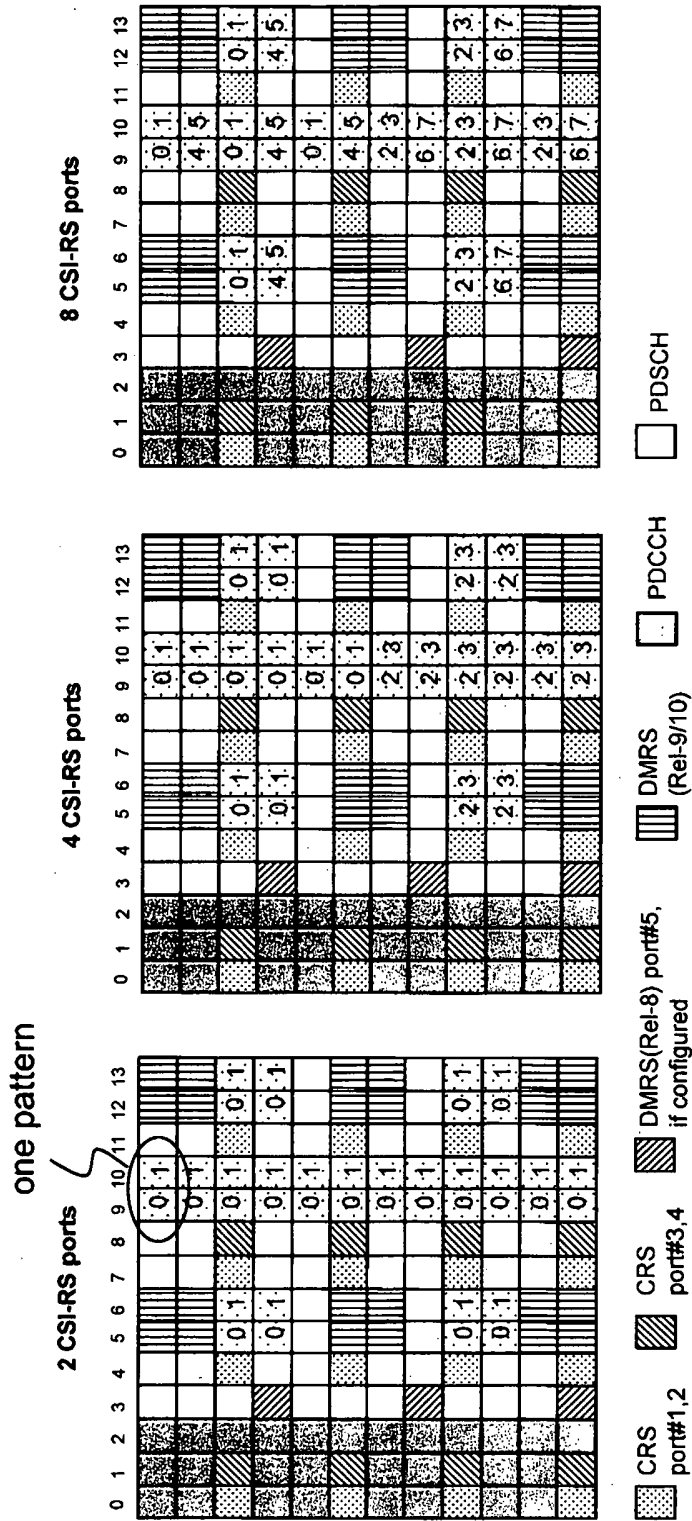

Figure 4

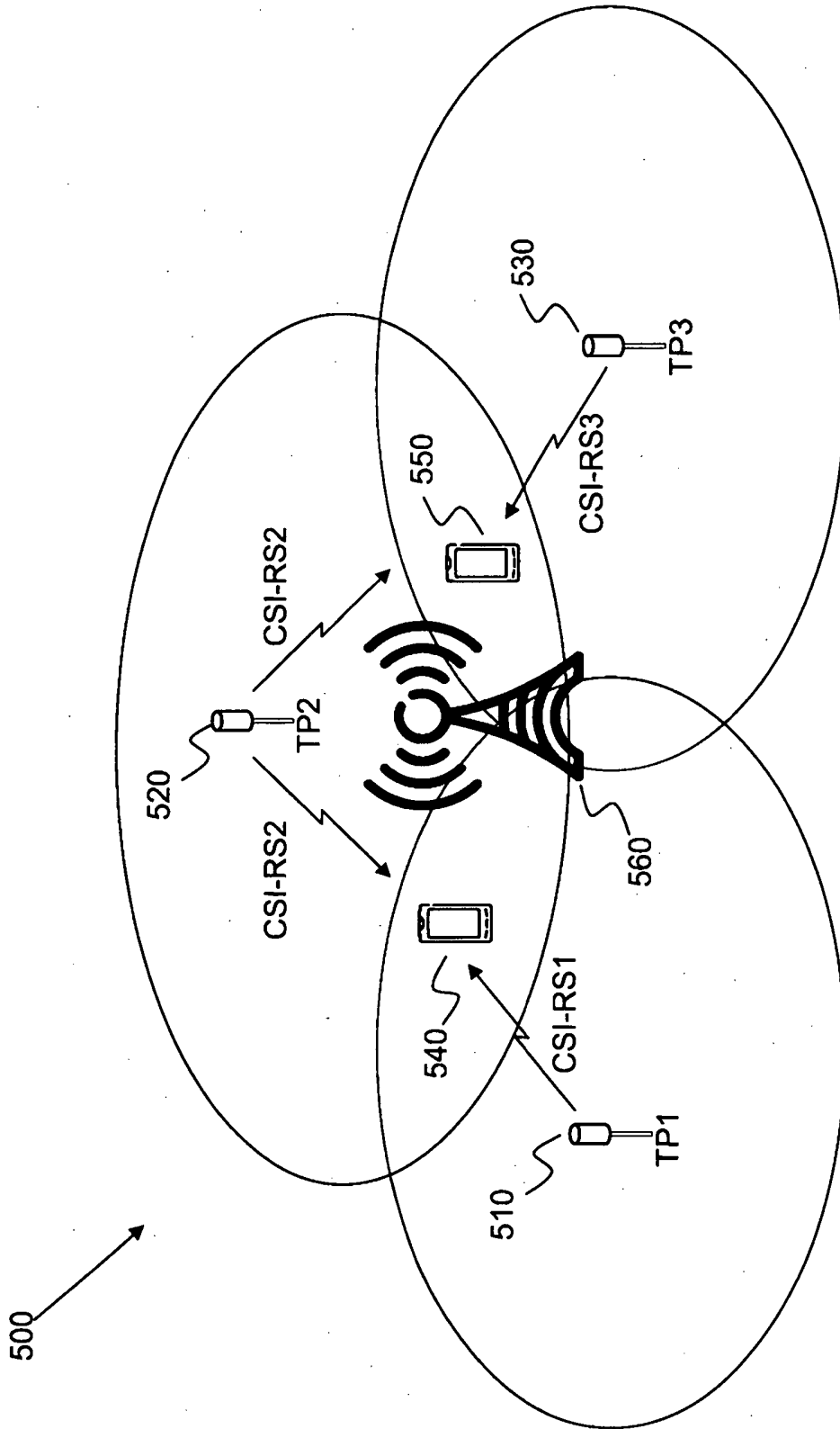

Figure 5

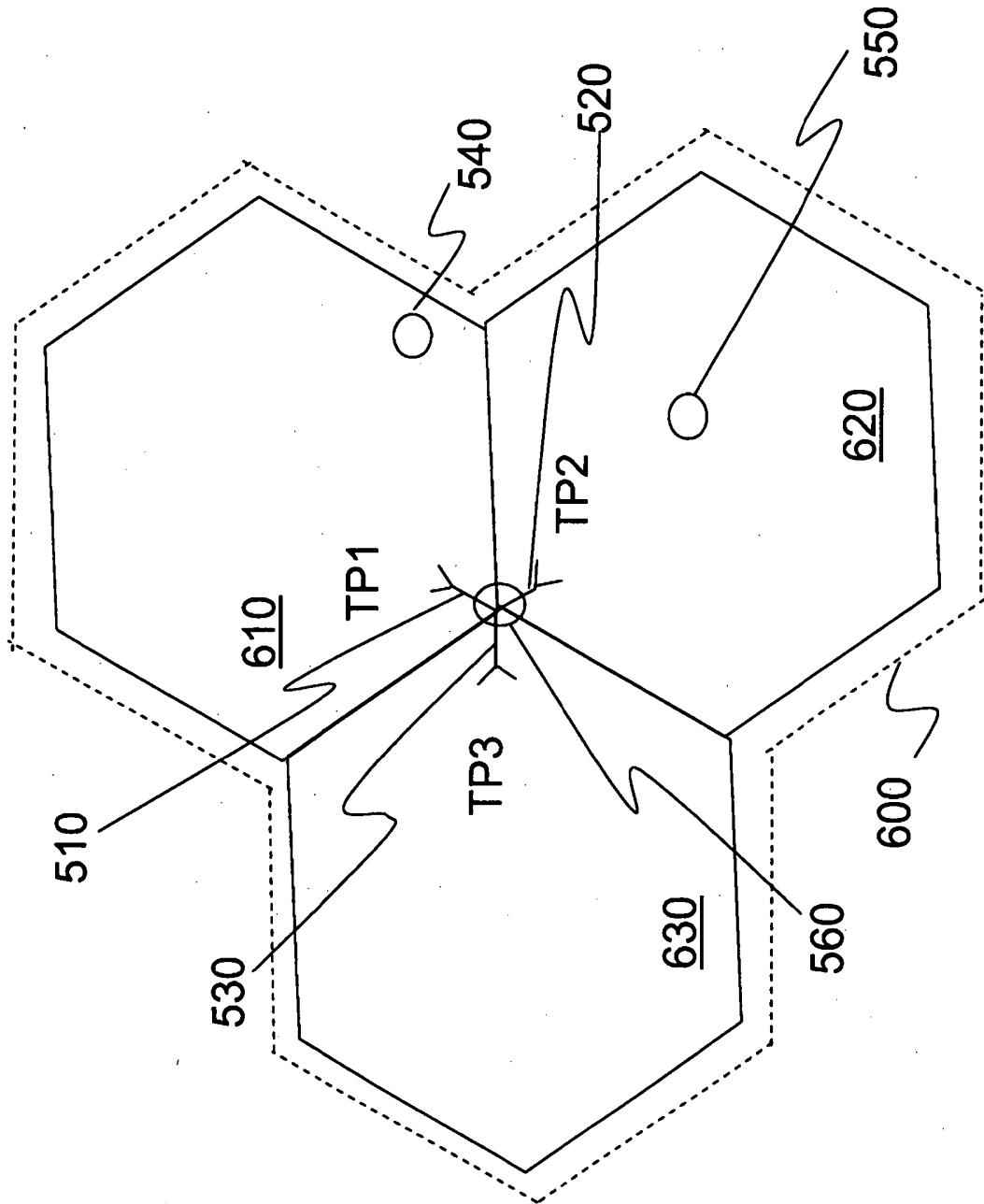

Figure 6

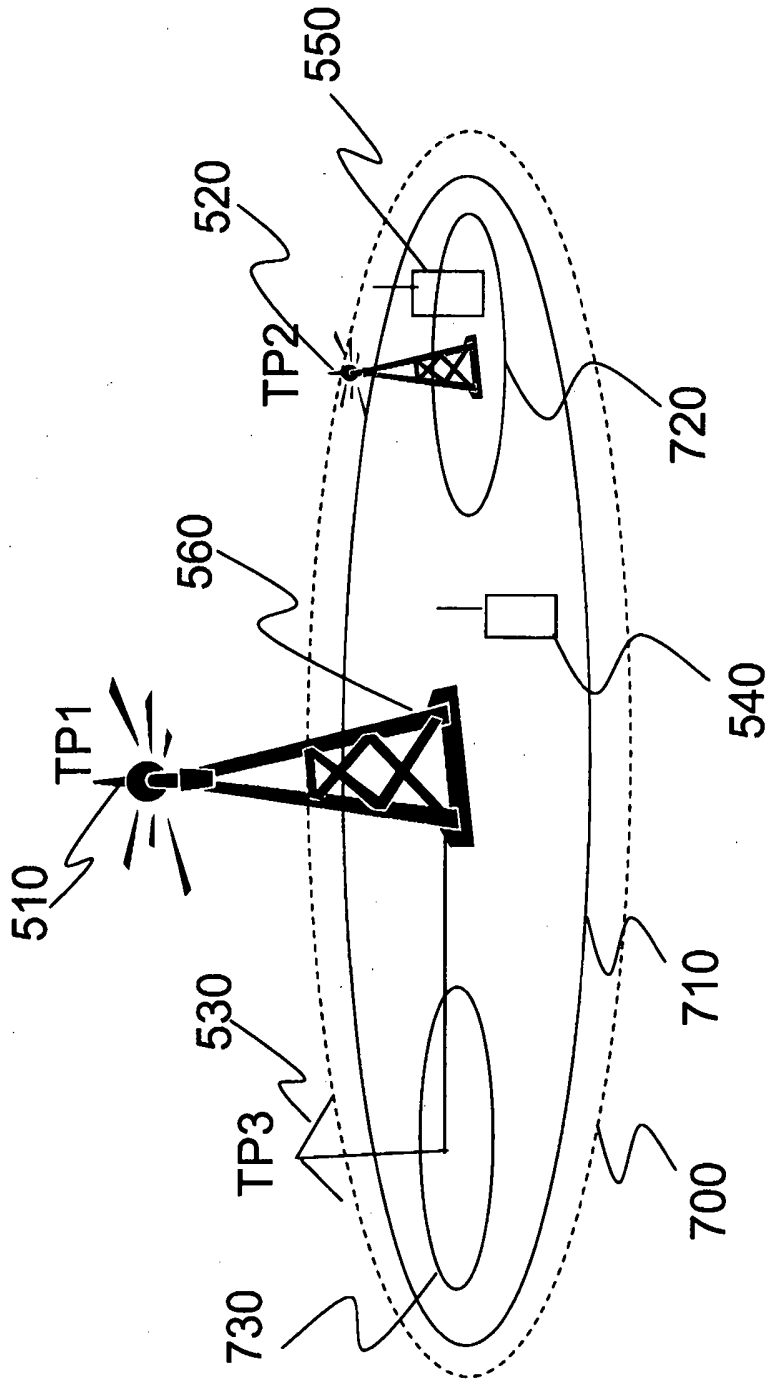

Figure 7

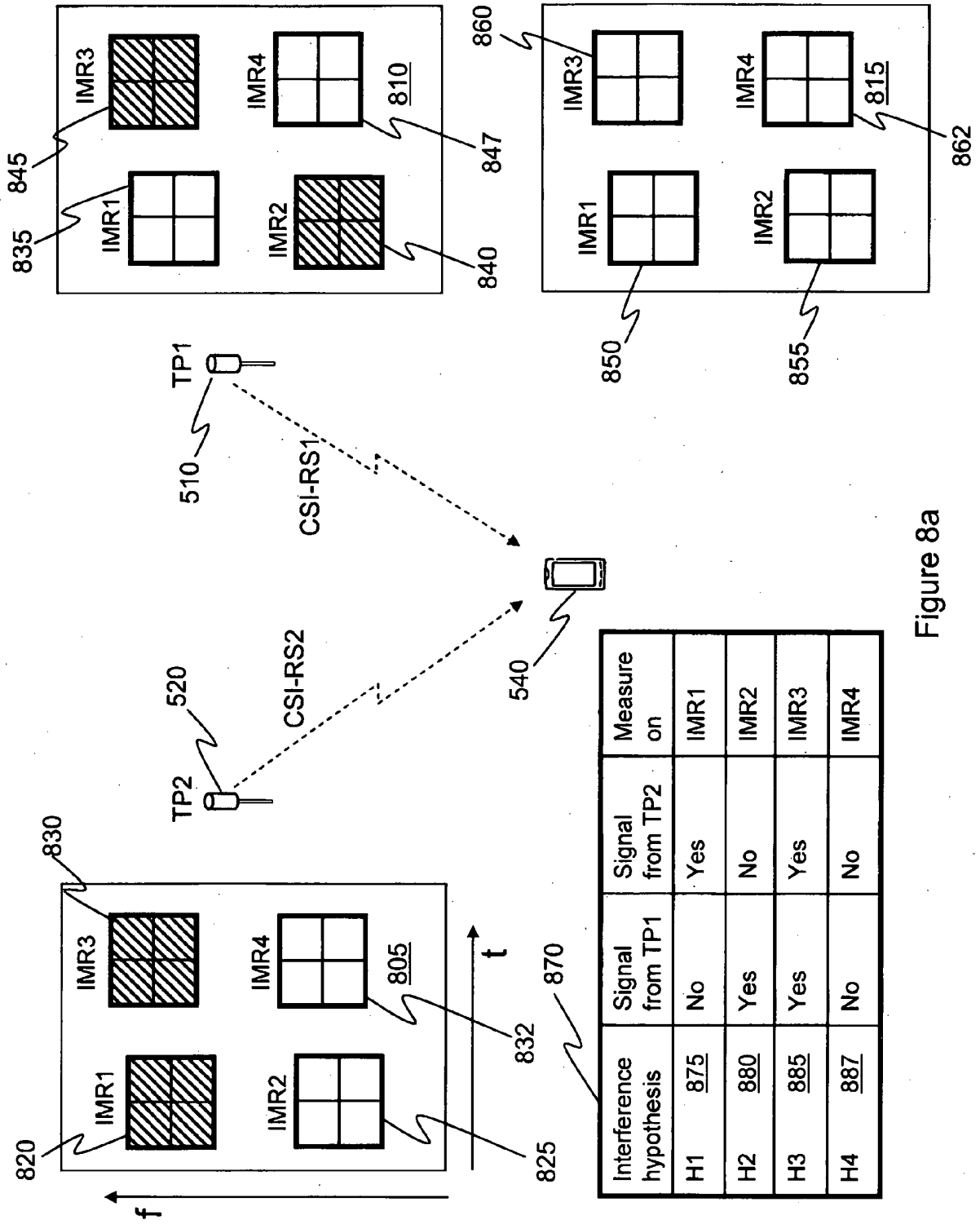

Figure 8a

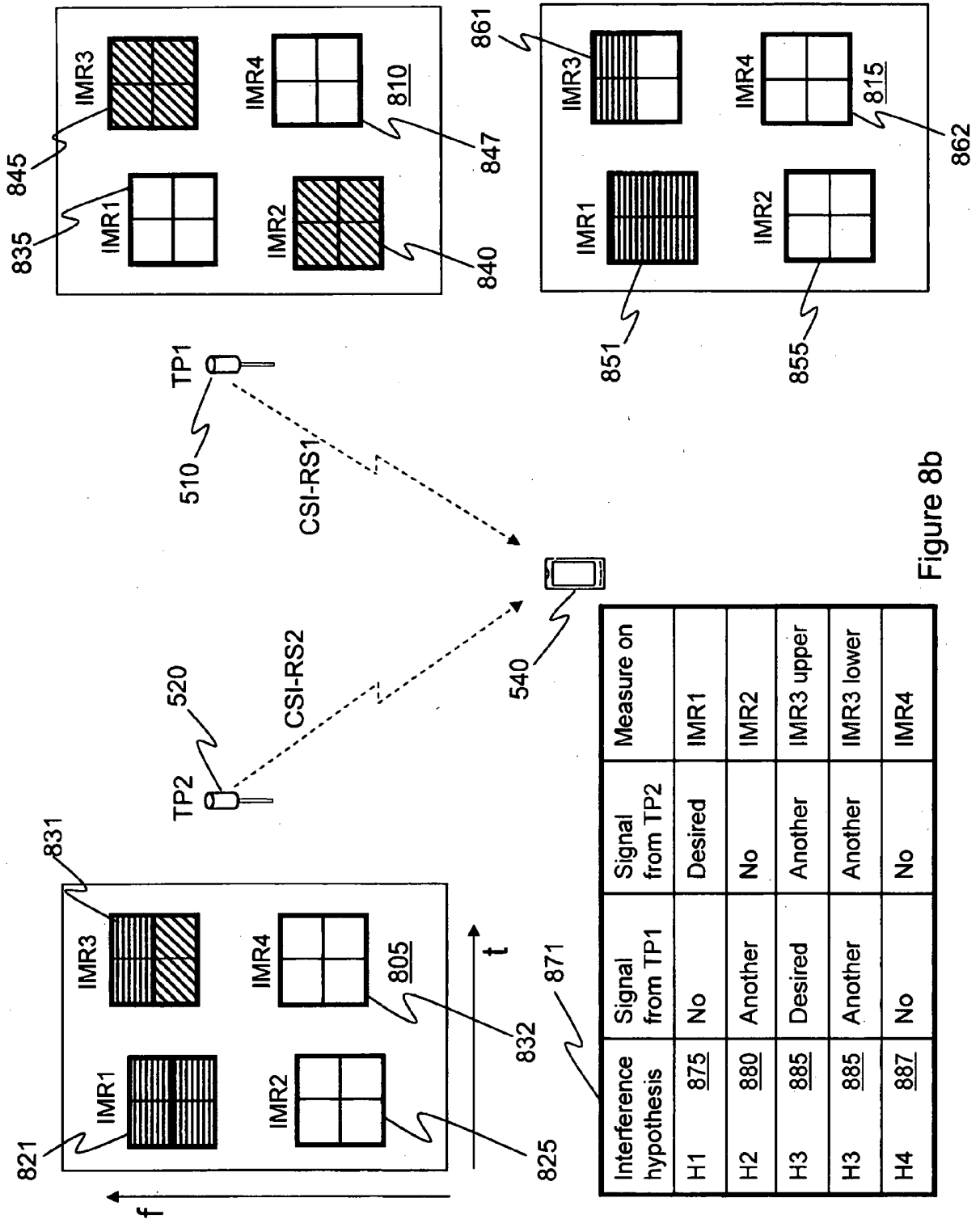

Figure 8b

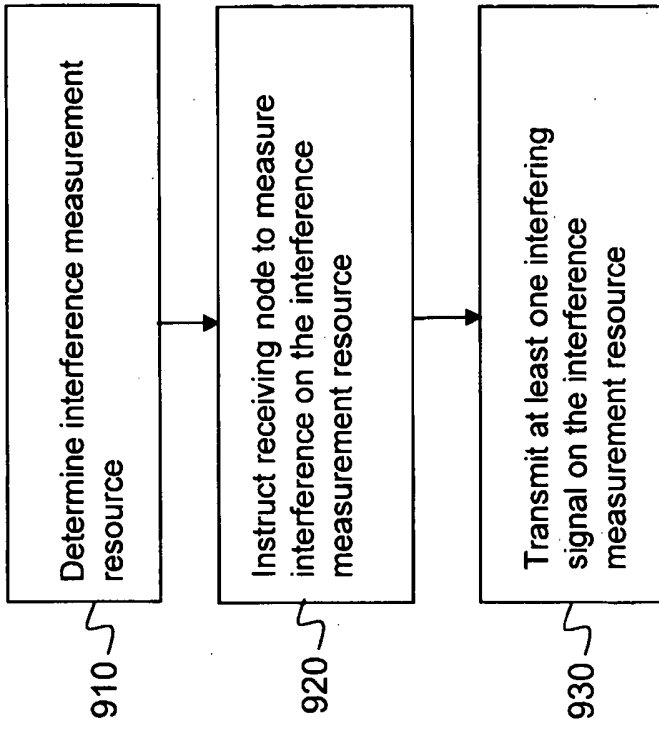

Figure 9b

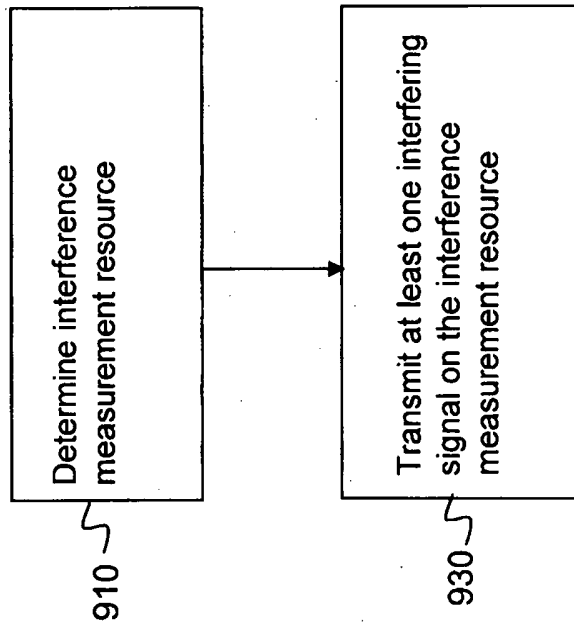

Figure 9a

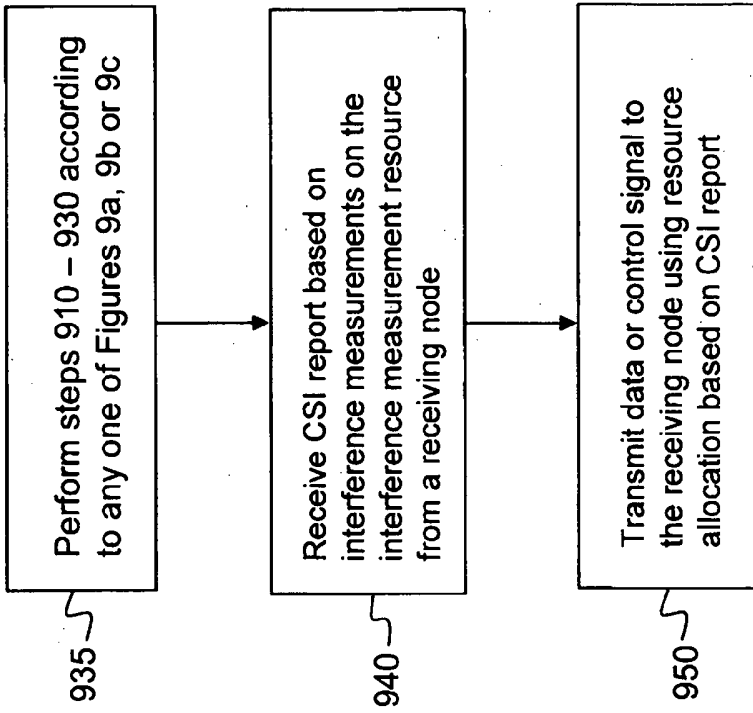

Figure 9d

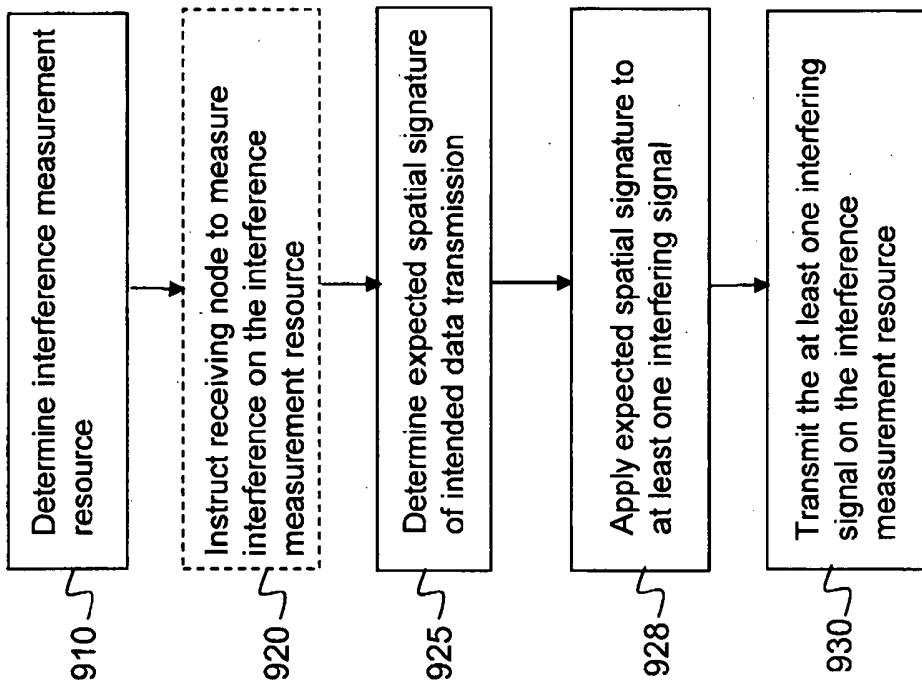

Figure 9c

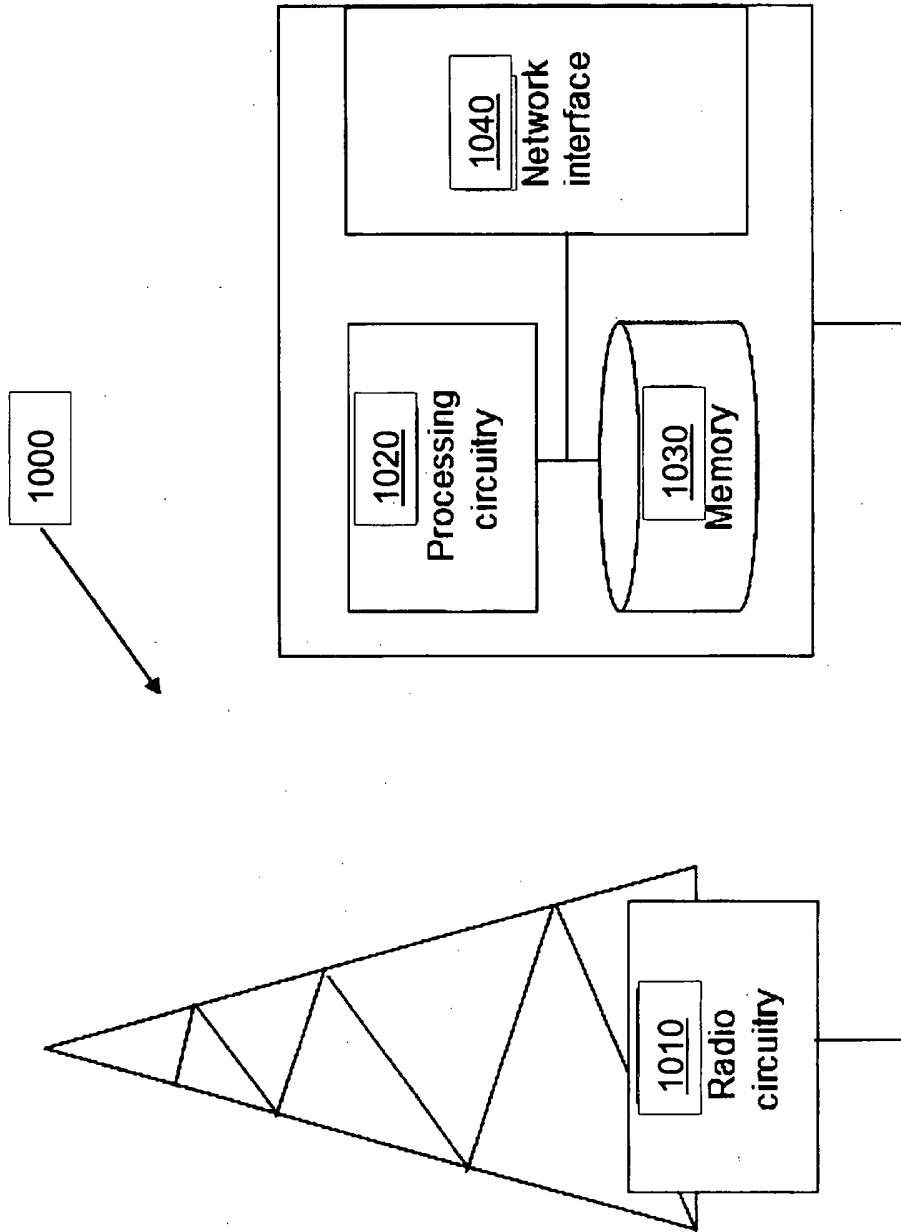

Figure 10a

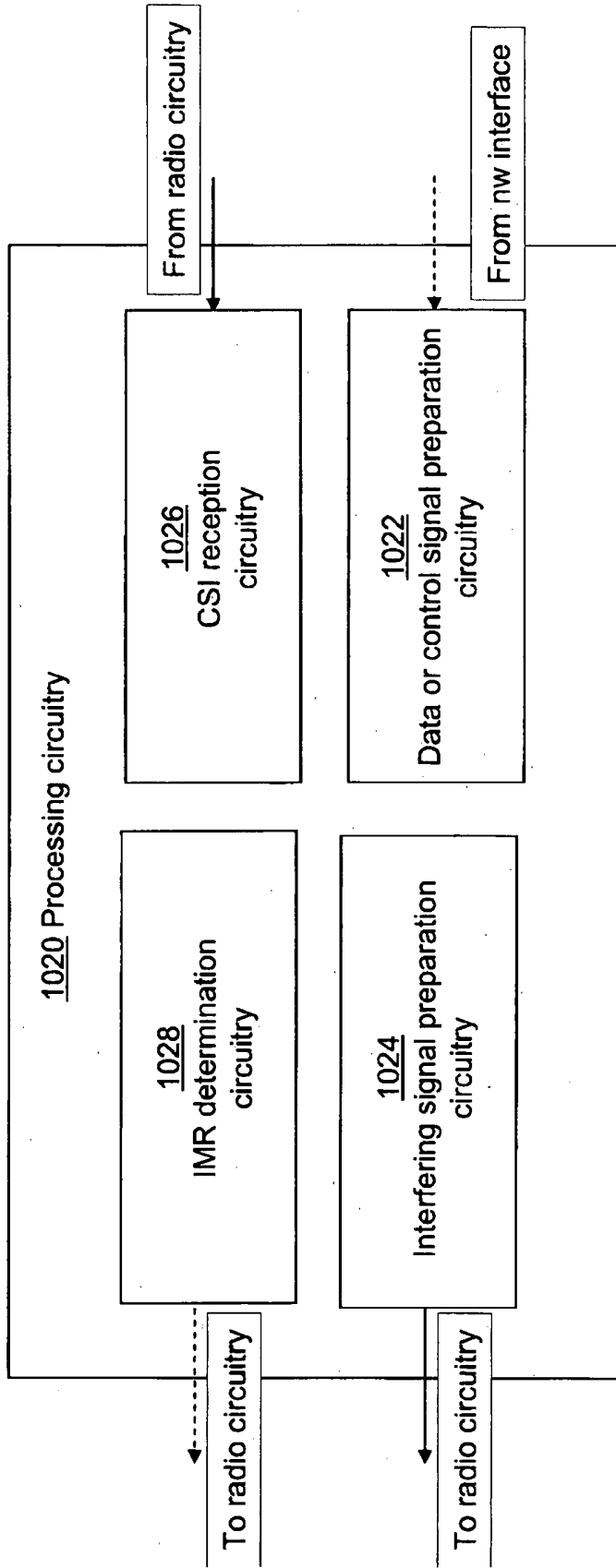

Figure 10b

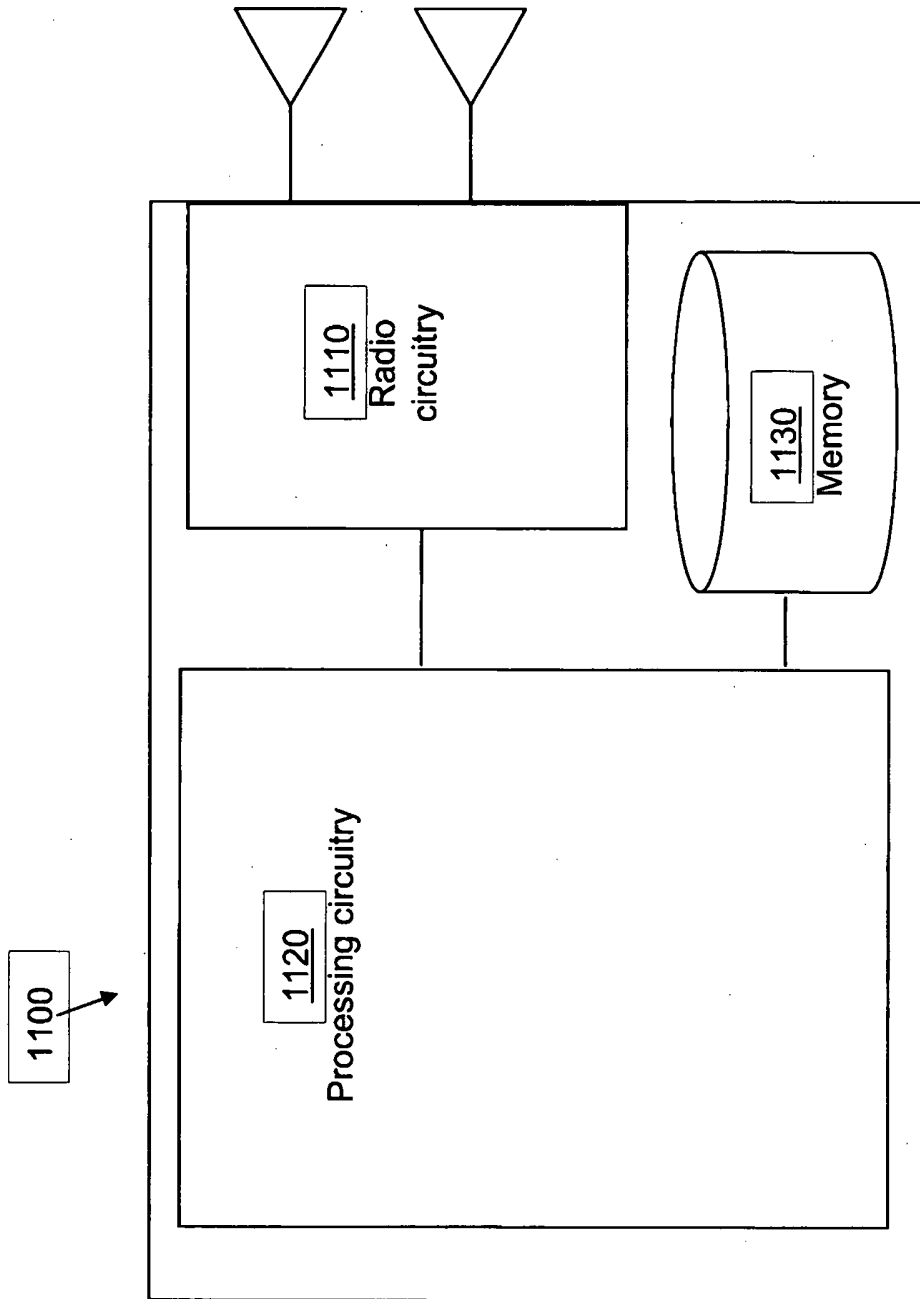

Figure 11a

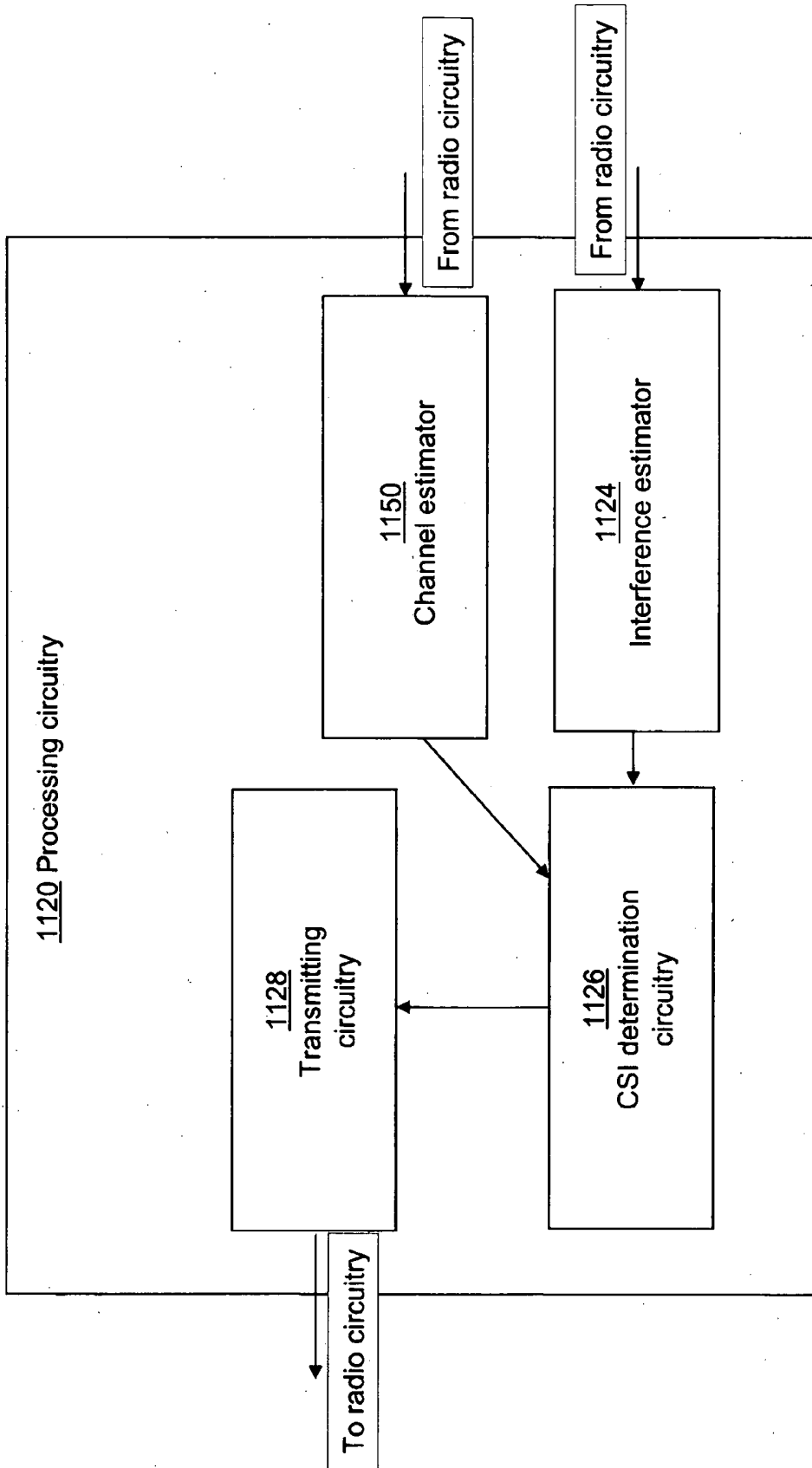

Figure 11b

ELJÁRÁS ÉS ELRENDEZÉS VEZETÉK NÉLKÜLI KOMMUNIKÁCIÓS RENDSZERBEN

Szabadalmi igénypontok

1. Eljárás adócsomópontban (560) vevőcsomópont (540) engedélyezésére, hogy az olyan interferencia méréseket végezzen, amelyet legalább egy olyan adáspontból (510, 520, 530) való adások okoztak, amelyet az adócsomópont (560) vezérel a vevőcsomóponton (540) való vételen, az adó- és a vevőcsomópont (560, 540) vezeték nélküli kommunikációs rendszerben (500, 600, 700) van, az eljárás a következőket tartalmazza:

IMR interferenciamérési erőforrás *meghatározása* (910), amely TFRE időfrekvencia-erőforrás elemek halmazát tartalmazza, amelyen az adócsomópont várhatóan interferenciát ad; és

legalább egy interferenciajel *adása* (930) az IMR-en az interferenciaként, ahol a legalább egy interferenciajel tartalmaz egy kívánt jelet, amelyet várhatóan dekódolnak vagy koherens módon mér a vevőcsomópont (540) vagy egy másik csomópont (550), amelyet az adócsomópont (560) szolgál ki,

az eljárást **azzal jellemezve, hogy** a legalább egy interferenciajel továbbá tartalmaz egy másik jelet, amely várhatóan nem lesz dekódolva vagy koherens módon mérve egyik csomópont (540, 550) által sem, amelyet az adócsomópont (560) szolgál ki, ahol a kívánt jelet a másik jel helyén adják legalább egy interferenciajelnél az IMR egy vagy több TFRE-jén, amikor a legalább egy adáspont arra szolgál, hogy a kívánt jelet a vevőcsomópontnak (540) vagy a másik csomópontnak (550) adja, amelyet az adócsomópont (560) szolgál ki, és ahol a másik jelet adják, ahol a másik jel elnémul az IMR TFRE-jein, ahol a kívánt jelet adják.

2. Az előző igénypont szerinti eljárás, amely továbbá tartalmazza egy továbbítandó alkeretre annak kiválasztását, hogy a kívánt jelet vagy a másik jelet adják-e az IMR egy vagy több TFRE-jén.

3. Az előző igénypontok egyike szerinti eljárás, ahol a kívánt jelet várhatóan dekódolja a vevőcsomópont (540) vagy egy másik csomópont (550), amelyet az adócsomópont (560) szolgál ki.
4. Az előző igénypontok egyike szerinti eljárás, ahol a kívánt jel egy adatjel, amelyet a fizikai lefelé irányuló kapcsolati megosztott csatormán adnak.
5. Az előző igénypontok egyike szerinti eljárás, ahol a különböző adópontokból (510, 520, 530) való adásokat összehangolják, hogy vezéreljék az interferenciát és/vagy javítsák a vett jelminőséget a vezeték nélküli kommunikációs rendszerben (500, 600, 700).
6. Az előző igénypontok egyike szerinti eljárás, ahol az interferenciaméréseket az adócsomópont (560) és a vevőcsomópont (540) közötti kommunikációs kapcsolat alkalmazására használják, az eljárás a következő további lépéseket tartalmazza:

CSI csatornaállapot-információ jelentés *vétele* (940) a vevőcsomóponttól (540), ahol a CSI jelentés legalább részben az IMR-en lévő vevőcsomópont (540) által végzett interferenciaméréseken alapul;

adat- vagy vezérlőjel *adása* (950) a vevőcsomópontnak (540) erőforrás-lefoglalás és/vagy kapcsolataalkalmazás segítségével, amely legalább részben a CSI jelentésen alapul.

7. Az előző igénypontok egyike szerinti eljárás, amely a következő további lépéseket tartalmazza: a vevőcsomópont (540) *utasítása* (920), hogy interferenciát mérjen az IMR-en.
8. Az előző igénypontok egyike szerinti eljárás, ahol a legalább egy adáspont (510, 520, 530) tartalmazza az adáspontok egy összeállítását, és ahol a legalább egy interferenciajel adása tartalmazza egy megfelelő interferenciajelnek az IMR-en való adását az adáspontok összeállításában lévő minden egyes adáspontból.
9. Az előző igénypont szerinti eljárás, ahol az adáspontok összeállítása úgy kerül kiválasztásra, hogy lehetővé teszi, hogy a vevőcsomópont (540) interferenciát mérjen, amely

legalább egy adáshipotézishez alkalmazható, amelyre a vevőcsomópont (540) jelenti a CSI csatornaállapot-információt az adócsomópontnak (560).

10. A 8 – 9. igénypontok egyike szerinti eljárás, ahol az adáspontok összeállítását az adócsomópont (560) választja ki.
11. A 8 – 9. igénypontok egyike szerinti eljárás, ahol az adáspontok összeállítását egy vezérlő csomópont választja ki, amely összehangolja a legalább egy adáspontból (510, 520, 530) való adásokat a legalább egy olyan további adáspontból való adásokkal, amelyet egy további adócsomópont vezérel a vezeték nélküli kommunikációs rendszerben (500, 600, 700).
12. Az előző igénypontok egyike szerinti eljárás, ahol az IMR egybeesik egy CRS cellára jellemző referencijel konfiguráció TFRE időfrekvencia-erőforrás elemeivel.
13. Az előző igénypont szerinti eljárás, ahol nem kerül adásra CRS a legalább egy adáspontból (510, 520, 530) a CRS konfiguráció TFRE-jein.
14. Az előző igénypont szerinti eljárás, ahol CRS kerül adásra a CRS konfiguráció TFRE-jein lévő szomszédos adáspontból, és ahol a legalább egy adáspontból (510, 520, 530) való adásokat összehangolják a szomszédos adáspontból való adásokkal.
15. Az 1 – 11. igénypontok egyike szerinti eljárás, ahol az IMR-t olyan CSI-RS csatornaállapot-információ referencijel-konfiguráció TFRE időfrekvencia-erőforrás elemeivel fedik le, amelyet a vevőcsomópont (540) alkalmaznak, és ahol a CSI-RS hatását semlegesíteni kell a vevőcsomópont (540) által az interferenciamérés végzésekor.
16. Az 1 – 11. igénypontok egyike szerinti eljárás, ahol az IMR olyan nulla teljesítményű CSI-RS csatornaállapot-információ referencijel konfiguráció TFRE időfrekvencia-erőforrás elemeivel van lefedve, amelyet a vevőcsomópont (540) alkalmaznak.
17. Az 1 – 11. igénypontok egyike szerinti eljárás, ahol egy bármely olyan csomópont (540, 550) által várhatóan dekódolandó vagy koherens módon mérendő további kívánt jelet,

amelyet az adócsomópont (560) szolgál ki, legalább egy olyan TFRE időfrekvenciaerőforrás elemen továbbítanak, amely egybeesik az IMR-rel, a továbbított legalább egy interferenciajelen kívül, és ahol a további kívánt jel hatását semlegesíteni kell a vevőcsomópont (540) által az interferenciamérés végzésekor.

18. Az előző igénypontok egyike szerinti eljárás, ahol a továbbított legalább egy interferenciajelen izotróp jel.
19. Az 1 – 17. igénypontok egyike szerinti eljárás, amely továbbá a következő lépéseket tartalmazza:
 - a vevőcsomópont (540) való tervezett adatátvitel várt térbeli aláírásának *meghatározása* (925);
 - a várt térbeli aláírás *alkalmazása* (928) a legalább egy interferenciajelen átvitelekor.
20. Az előző igénypont szerinti eljárás, ahol a várt térbeli aláírás meghatározása a vevőcsomópont (540) megfelelő pufferállapota, valamint az adócsomópont (560) által kiszolgált legalább egy további vevőcsomópont (550) előzményi CSI jelentései alapján történik.
21. Az előző igénypontok egyike szerinti eljárás, ahol a meghatározott IMR olyan TFRE-k halmazának részhalmaza, amelyen a vevőcsomópont (540) arra van kialakítva, hogy ne várjon adatátvitelt egyik legalább egy adásponttól (510, 520, 530) sem.
22. Az előző igénypont szerinti eljárás, ahol a TFRE-k halmaza a nulla teljesítményű CSI-RS csatornaállapot-információ referencijel-konfigurációk halmaza.
23. Az előző igénypontok egyike szerinti eljárás, ahol a meghatározott IMR az adócsomópont (560) által kiszolgált bármely vevőcsomópont (540, 550) vonatkozik.
24. Adócsomópont (560, 1000), amely arra van kialakítva, hogy engedélyezze egy vevőcsomópontnak (540), hogy interferenciaméréseket végezzen, az adócsomópont (560, 1000) arra van konfigurálva, hogy csatlakoztatható legyen legalább egy adócsomóponttal.

ponthoz (510, 520, 530) vezeték nélküli kommunikációs rendszerben (500, 600, 700), ahol a vevőcsomópontoknál való vételnek ki vannak téve a legalább egy adócsomópontból (510, 520, 530) való adások által okozott interferenciának, az adócsomópont (560, 1000) a következőket tartalmazza:

feldolgozó áramkör (1020), amely arra van kialakítva, hogy meghatározzon egy IMR interferenciamérő erőforrást, amely TFRE időfrekvencia-erőforrás elemek halmazát tartalmazza, amelyeken az adócsomópont várhatóan interferenciát ad, a feldolgozó áramkör (1020) továbbá arra van kialakítva, hogy interferenciát továbbítson a legalább egy adásponton (510, 520, 530) keresztül, valamint egy interferenciajelet továbbítson az IMR-en, ahol a legalább egy interferenciajel tartalmaz egy kívánt jelet, amelyet a vevőcsomópont (540) vagy az adócsomópont (560) által kiszolgált másik csomópont (550) várhatóan dekódol vagy koherens módon mér,

az adócsomópontot (560, 1000) **azzal jellemezve, hogy** a legalább egy interferenciajel továbbá tartalmaz egy másik jelet, amely várhatóan nem lesz dekódolva vagy koherens módon mérve egyik csomópont (540, 550) által sem, amelyet az adócsomópont (560, 1000) szolgál ki, a feldolgozó áramkör (1020) továbbá arra van kialakítva, hogy továbbítsa a kívánt jelet a másik jel helyén legalább egy interferenciajelnél az IMR egy vagy több TFRE-jén, amikor a legalább egy adáspont (510, 520, 530) arra szolgál, hogy a kívánt jelet a vevőcsomópontnak (540) vagy a másik csomópontnak (550) adja, amelyet az adócsomópont (560) szolgál ki, a feldolgozó áramkör (1020) továbbá arra van kialakítva, hogy továbbítsa a másik jelet az IMR TFRE-jein, ahol nem adnak kívánt jelet, és elnémissza a másik jelet az IMR TFRE-jein, ahol a kívánt jelet adják.

25. A 24. igénypont szerinti adócsomópont (560, 1000), ahol az adócsomópont (560, 1000) arra van kialakítva, hogy felhasználja az interferenciaméréseket az adócsomópont (560, 1000) és a vevőcsomópont (540) közötti kommunikációs kapcsolat alkalmazásához, a feldolgozó áramkör (1020) továbbá a következőkre van kialakítva:

CSI csatornaállapot-információ jelentés vétele a legalább egy adásponton (510, 520, 530) keresztül a vevőcsomóponttól (540), ahol a CSI jelentés legalább rész-

ben az IMR-en lévő vevőcsomópont (540) által végzett interferenciaméréseken alapul; és

adat- vagy vezérlőjel adása legalább egy adásponton (510, 520, 530) keresztül a vevőcsomópontnak (540) erőforrás-lefoglalás és/vagy kapcsolataalkalmazás segítségével, amely legalább részben a CSI jelentésen alapul.

26. A 24 – 25. igénypontok egyike szerinti adócsomópont (560, 1000), ahol a feldolgozó áramkör (1020) továbbá a következőkre van kialakítva:

a vevőcsomópont (540) utasítása a legalább egy adásponton (510, 520, 530) keresztül az IMR-en való interferenciamérésre.

27. A 24 – 26. igénypontok egyike szerinti adócsomópont (560, 1000), ahol a legalább egy adáspont (560, 1000) tartalmazza az adáspontok egy összeállítását, és ahol a feldolgozó áramkör (1020) arra van kialakítva, hogy továbbítsa a legalább egy interferenciajelet megfelelő interferenciajelnek az IMR-en az adáspontok összeállításában lévő minden egyes adásponton keresztül való adásával.

28. A 24 – 27. igénypontok egyike szerinti adócsomópont (560, 1000), ahol a feldolgozó áramkör (1020) arra van kialakítva, hogy meghatározza az IMR-t, mint a TFRE-k részhalmazát, amelyen a vevőcsomópont (540) arra van kialakítva, hogy ne várjon adatátvitelt egyik legalább egy adásponttól (510, 520, 530) sem.

29. Az előző igénypont szerinti adócsomópont (560, 1000), ahol a TFRE-k halmaza a nulla teljesítményű CSI-RS csatornaállapot-információ referenciajel-konfigurációk halmaza.