



(51) International Patent Classification:

*B29D 11/00* (2006.01)    *B29C 51/08* (2006.01)  
*B29C 43/20* (2006.01)    *G02B 5/30* (2006.01)  
*B29C 51/10* (2006.01)    *G02B 27/28* (2006.01)

(21) International Application Number:

PCT/IB2012/000752

(22) International Filing Date:

16 April 2012 (16.04.2012)

(25) Filing Language:

English

(26) Publication Language:

English

(30) Priority Data:

61/475,885    15 April 2011 (15.04.2011)    US

(71) Applicant (for all designated States except US): **POLAR-  
OID EYEWEAR A DIVISION OF STYLEMARK UK,  
LTD.** [GB/GB]; Vale of Leven Industrial Estate, Dumbar-  
ton, G82 2PW, Scotland (GB).

(72) Inventors; and

(75) Inventors/Applicants (for US only): **BOINARD, Eric**  
[FR/GB]; VALE OF LEVEN INDUSTRIAL ESTATE,  
DUMBARTON G82 3PW, SCOTLAND (GB).  
**BOINARD, Pascal** [FR/GB]; VALE OF LEVEN INDUS-  
TRIAL ESTATE, DUMBARTON G82 3PW, SCOTLAND  
(GB).

(81) Designated States (unless otherwise indicated, for every

kind of national protection available): AE, AG, AL, AM,  
AO, AT, AU, AZ, BA, BB, BG, BH, BR, BW, BY, BZ,  
CA, CH, CL, CN, CO, CR, CU, CZ, DE, DK, DM, DO,  
DZ, EC, EE, EG, ES, FI, GB, GD, GE, GH, GM, GT, HN,  
HR, HU, ID, IL, IN, IS, JP, KE, KG, KM, KN, KP, KR,  
KZ, LA, LC, LK, LR, LS, LT, LU, LY, MA, MD, ME,  
MG, MK, MN, MW, MX, MY, MZ, NA, NG, NI, NO, NZ,  
OM, PE, PG, PH, PL, PT, QA, RO, RS, RU, RW, SC, SD,  
SE, SG, SK, SL, SM, ST, SV, SY, TH, TJ, TM, TN, TR,  
TT, TZ, UA, UG, US, UZ, VC, VN, ZA, ZM, ZW.

(84) Designated States (unless otherwise indicated, for every

kind of regional protection available): ARIPO (BW, GH,  
GM, KE, LR, LS, MW, MZ, NA, RW, SD, SL, SZ, TZ,  
UG, ZM, ZW), Eurasian (AM, AZ, BY, KG, KZ, MD, RU,  
TJ, TM), European (AL, AT, BE, BG, CH, CY, CZ, DE,  
DK, EE, ES, FI, FR, GB, GR, HR, HU, IE, IS, IT, LT, LU,  
LV, MC, MK, MT, NL, NO, PL, PT, RO, RS, SE, SI, SK,  
SM, TR), OAPI (BF, BJ, CF, CG, CI, CM, GA, GN, GQ,  
GW, ML, MR, NE, SN, TD, TG).

Published:

— without international search report and to be republished  
upon receipt of that report (Rule 48.2(g))

(54) Title: CURVED LENSES AND RELATED METHODS

(57) Abstract: Curved lenses and methods for making curved lenses are described. One embodiment of a method of making a curved lens includes curving a lens blank made of a linear polarizer layer laminated together with a plurality of polymeric layers. The lens blank is curved by heating and pressing the lens blank between a curved rigid member and a flexible member at a pressure and maintaining the pressure for a time sufficient to allow the lens blank to conform to the shape of the curved rigid member. Methods of the invention may be used to make curved lenses with different polarization properties and curvatures.



## CURVED LENSES AND RELATED METHODS

### CROSS-REFERENCE TO RELATED APPLICATION

**[0001]** The application claims priority to U.S. Provisional Application Serial No. 61/475,885 titled "Apparatus and Method for Shaping Light Polarizers," which was filed on April 15, 2011 and is incorporated herein by reference in its entirety.

### FIELD OF THE INVENTION

**[0002]** The invention relates to the field of polarized eyewear, and, more particularly, to curved polarized lenses and eyewear having curved polarized lenses.

### BACKGROUND

**[0003]** Light polarizing lenses such as those incorporated into sunglasses or other eyewear are preferably shaped to comply with fashion trends, to minimize the amount of light that can disturb the wearer's peripheral vision and to minimize the appearance of reflections. Unfortunately, there are currently very few techniques that can transform planar polarizing lens blank materials into a curved lens. The techniques that exist may suffer from one or more of the following drawbacks: some can produce only very thin lenses, the lens production process is not adapted for efficient automation, they may involve time consuming grinding processes, or the forming process may damage the linear polarizer.

### SUMMARY

**[0004]** In view of the foregoing, it is an object of the invention to provide curved polarizer lenses, which can be produced according to efficiently automated processes that impart minimal damage to the delicate linear polarizer material.

**[0005]** According to a method aspect of the invention, a formed lens is prepared from a lens blank made of a linear polarizer layer laminated together with a plurality of polymeric layers, the linear polarizer layer having a polarization axis. Heat and pressure are applied to the lens blank by pressing the lens blank between a curved rigid member and a flexible member, thereby causing the flexible member to assume the shape of the curved rigid member. The pressure is maintained for a time sufficient to allow the lens blank to conform to the shape of the curved rigid member and the flexible member.

**[0006]** In another method aspect of the invention, a formed lens is prepared from a lens blank made of a linear polarizer layer laminated together with a plurality of polymeric layers, the linear polarizer layer having a polarization axis. The lens blank is heated to a forming temperature by pressing the lens blank between a curved rigid member and a flexible member, the curved rigid member being at the forming temperature. The pressure is maintained while heating at the forming temperature for allowing the lens blank to conform to the shape of the curved rigid member. The temperature is reduced to a reduced temperature while maintaining the pressure for allowing the lens blank to become a rigid lens having a convex side and a concave side. The rigid lens is then removed from between the curved rigid member and the flexible member.

**[0007]** In another method aspect of the invention, eyewear is prepared from a first lens and a second lens made of a linear polarizer layer laminated together with a plurality of polymeric layers, the linear polarizer layer having a polarization axis. The first lens and second lens are formed from lens blanks into a desired shape according to the following steps: (i) heating and pressing the lens blanks separately between a curved rigid member and a flexible member at a pressure, thereby causing the flexible member to assume the shape of the curved rigid member, (ii) maintaining the pressure for a time sufficient to allow the lens blanks to conform to the shape of the curved rigid

member and the flexible member. The formed first and second lenses are then placed into an eyeglass frame.

**[0008]** The following are preferred forming parameters that may optionally be used in methods of the invention. Heating is preferably conducted at about 70°C to about 200°C. The pressure is about 1.5 to about 15 MPa.

**[0009]** In some embodiments, a method may comprise cooling the lens blank while maintaining the pressure. Cooling may be conducted at about 20°C to about 90°C.

**[0010]** In some embodiments, a method may comprise, heating the lens blank to a temperature of between about 20°C to about 150°C prior to placing the lens blank between the curved rigid member and flexible member and pressing the lens blank.

**[0011]** In certain embodiments, at least one of the polymeric layers is an optical wave retarder having fast and slow axes and the fast retarder axis is aligned at an angle relative to the polarizer axis. The angle may be chosen to render the lens a linear polarizer, an elliptical polarizer, or a circular polarizer.

**[0012]** In embodiments in which the lens is a circular polarizer, an anti-reflective coating may be applied to the concave surface and convex surface of the formed lens. This advantageously allows the formed lens to have a parallel polarizer transmittance equal to or greater than 90% and a cross polarizer transmittance equal to or less than 0.5%.

**[0013]** In some embodiments, the shape of the curved rigid member may be adjusted to produce a spherically, toroidally, or cylindrically shaped lens. A spherically shaped lens has a first radius of curvature and a second radius of curvature perpendicular to the first radius of curvature, wherein the first radius of curvature and second radius of curvature are equal. A toroidally shaped lens has a first radius of curvature and a second radius of curvature perpendicular to the first radius of curvature, wherein the first radius of

curvature and second radius of curvature are not equal. A cylindrically shaped lens has a first radius of curvature and a second radius of curvature perpendicular to the first radius of curvature, wherein the first radius of curvature is non-zero and second radius of curvature is about zero.

**[0014]** Embodiments of the invention also include eyeglass lenses made according to method aspects of the invention.

**[0015]** These and other objects, aspects, and advantages of the present invention will be better appreciated in view of the drawings and following detailed description of the preferred embodiments.

#### BRIEF DESCRIPTION OF THE DRAWINGS

**[0016]** FIG. 1 is a side elevation view of a preferred composite light polarizer sheet that can be used to form a lens in accordance with an embodiment of the invention;

**[0017]** FIG. 2 is a side elevation view of another preferred composite light polarizer sheet that can be used to form a lens in accordance with an embodiment of the invention;

**[0018]** FIG. 3 is a side elevation view of another preferred composite light polarizer sheet that can be used to form a lens in accordance with an embodiment of the invention;

**[0019]** FIG. 4. is a plan view of a preferred composite light polarizer sheet from which a lens blank can be cut, showing the alignment of the transmission axis of the linear polarizer layer and the fast axis of the retarder layer;

**[0020]** FIG. 5 is a plan view of a section of a composite light polarizer sheet, showing how lens blanks may be cut therefrom;

**[0021]** FIG. 6 is a plan view of a lens blank removed from the section of composite light polarizer sheet of FIG. 4.

**[0022]** FIG. 7 is a cross-sectional view of an apparatus that can be used to curve lens blanks into lenses according to a method aspect of the invention;

**[0023]** FIG. 8 is a cross-sectional view of the apparatus of FIG. 7 during a pressure stage of a method aspect of the invention;

**[0024]** FIG. 9 is a cross-sectional view of the apparatus of FIG. 7, showing a curved lens removed from the apparatus;

**[0025]** FIGS. 10A-C are schematics of spherically, toroidally, and cylindrically shaped lenses, respectively, made according to a method aspect of the invention;

**[0026]** FIG. 11 is a perspective view of eyeglasses incorporating lenses of the invention;

**[0027]** FIG. 12 is a cutaway view of a curved lens including a hard coating in accordance with an embodiment of the invention; and

**[0028]** FIG. 13 is a cutaway view of a curved lens including an anti-reflective coating in accordance with an embodiment of the invention.

#### DETAILED DESCRIPTION OF PREFERRED EMBODIMENTS

**[0029]** In the Summary above and in the Detailed Description of Preferred Embodiments, reference is made to particular features (including method steps) of the invention. It is to be understood that the disclosure of the invention in this specification includes all possible combinations of such particular features. For example, where a particular feature is disclosed in the context of a particular aspect or embodiment of the invention, that feature can also be used, to the extent possible, in combination with and/or in the context

of other particular aspects and embodiments of the invention, and in the invention generally.

**[0030]** The term “comprises” is used herein to mean that other features, steps, etc. are optionally present. When reference is made herein to a method comprising two or more defined steps, the steps can be carried in any order or simultaneously (except where the context excludes that possibility), and the method can include one or more steps which are carried out before any of the defined steps, between two of the defined steps, or after all of the defined steps (except where the context excludes that possibility).

**[0031]** This invention may be embodied in many different forms and should not be construed as limited to the embodiments set forth herein.

**[0032]** It is desirable for curved devices that include a light-polarizing layer and that are suitable for application in the manufacture of eyewear to have durability and abrasion resistance appropriate for the application for which they will be used. It is also desirable that they be manufacturable by a method adapted efficiently to automated production operations. Ideally, such devices should not lose any of their light-polarizing qualities during the manufacturing process.

**[0033]** A conventional process for shaping light polarizing lenses uses injection molding. It will be appreciated that injection molding operations are complicated and relatively slow insofar as production operations are concerned. Achieving a desired lens curvature by resorting to methods based upon in-mold polymerization or grinding of each lens individually will likewise be slow and costly.

**[0034]** The production of curved light-polarizing lenses can be accomplished by individually shaping (molding) blanks made of a plastic light-polarizing composite or structure, such as is shown in U.S. Pat. No. 3,560,076 to F. G. Ceppi. However, such a method is difficult to implement due to the complex geometry of the mating molds.

**[0035]**As will be described below, the invention described here overcomes these drawbacks. The inventors have advantageously developed thick and durable curved lenses with minimal or no damage to the linear polarizer material using a unique forming process involving curving the lens blanks in a simple and cost efficient manner.

**[0036]**FIGS. 1-3 illustrate exemplary composite light polarizer sheets from which the curved polarized lenses of the invention may be formed. Referring initially to FIG. 1, an exemplary sheet 1 includes a polarizer layer 12 laminated between first and second polymeric layers 14, 16. A protective hardcoat layer 5 is coated on top of both polymeric layers 14, 16. Referring to FIG. 2 another exemplary sheet 10 includes a polarizer layer 12 laminated between first and second polymeric layers 14, 16 and a retarder layer 18 laminated to the second polymeric layer 16. Referring now to FIG. 3, an alternative example of a sheet 20 includes a polarizer layer 12 laminated to a first polymeric layer 14 on one side and to a retarder layer 18 on the other side. A second polymeric layer 16 is laminated to the retarder layer 18 on the side of the retarder layer 18 that is opposite the polarizer layer 12.

**[0037]**The polarizer layer 12 is preferably a linear polarizer, which may be made of any number of suitable linear polarizer materials such as H-type or K-type polarizers. In a preferred example, the polarizer material is made from a linear molecularly oriented dichroic light-polarizing material. Such materials typically have a thickness in the range of about 0.025 to 0.076 mm. A preferred material to serve as the light polarizer is a layer of stretched (oriented) polyvinyl alcohol of about 0.025mm thickness, which is stained with a dichroic dye such as iodine. Optionally, the polarizer may be borated to improve stability. Polarizers of this type are disclosed in U.S. Reissue Pat. Re. 23,297 and in U.S. Pat. No. 4,166,871.

**[0038]**Alternatively, the polarizer material may be a stretched polyvinyl alcohol (PVA) sheet containing polyvinylene light-polarizing species such as may be provided by typical hydrochloric acid vapor processing. Preferably, such



polarizing material will be borated for improved stability. Suitable light-polarizing materials of this type can be prepared according to U.S. Pat. No. 2,445,555. Other light polarizing materials such as those described in U.S. Pat. Nos. 2,237,567; 2,527,400; and 2,554,850 may also be used. Regardless of the type of polarizer material used, the polarizer material may be sandwiched to or between one or more support layers, such as a polymeric material layer **14**, **16** to provide mechanical strength to the polarizer layer **12**.

**[0039]** The polymeric layers **14**, **16** are preferably made from one or more thermoplastic polymers, which are polymers that can be formed to a desired shape by applying temperature and/or pressure. Suitable polymers include, but are not limited to, cellulose derivatives such as cellulose acetate, cellulose diacetate, cellulose triacetate, or cellulose acetate butyrate; acrylate derivatives such as polymethylmethacrylate (PMMA); polycarbonates; polyamides, polyurethanes; polypropylenes; polyethylenes; or cyclo-olefin based polymers or copolymers. The polymeric material layers **14**, **16** may be made from a single layer of a single polymer, a single layer of a blend of polymers, multiple laminated layers of a single polymer, or multiple laminated layers made of different polymers or a blend of polymers.

**[0040]** It is preferred that the polymeric layers **14**, **16** provide durability, mechanical strength, and scratch resistance to the sheet **12** and the finished curved lens made from the sheet **12**. In some cases, it may be beneficial to use polymers that either carry or may be provided with a suitable protective coating such a polymeric hard coating **5** that can withstand the temperatures and pressures used in the forming process. Suitable protective coatings include polyurethanes, polyacrylates, or urea-based resins.

**[0041]** The retarder layer **18** is preferably made from a light transmissive birefringent material such as a cyclo-olefin based polymer or co-polymer. Other suitable materials that can be used to form the retarder layer **18** include, but are not limited to, acrylate based polymer, polypropylenes, polyesters,

cellulose acetate based polymers, PVA, polystyrenes, polycarbonates, and norbornene based polymers and co-polymers.

[0042] One or more additives may be included in the polarizer layer 12, polymeric layers 14, 16 and/or retarder layer 18. For example, stabilizers, UV absorbers, and colorant dyes may be employed depending on the desired properties of the finished curved optical filter.

[0043] The polarizer layer 12 and retarder layer 18 include axes that may be aligned relative to one another to produce a desired polarization effect. Referring to FIG. 4, an exemplary sheet 30 having polarizer layer 12 and a retarder layer 18 is shown. The polarizer layer 12 has a transmission axis T aligned at the angle  $\theta$ . The fast axis R of the retarder layer 18, is aligned at the angle  $\varphi = \theta + \beta$  where  $\beta$  is the angular offset of the fast axis R of the retarder layer 18 relative to the transmission axis T of the polarizer layer 12. When  $\beta = (n-1) (\pi/2)$  with n an integer, the two axes are either parallel or orthogonal to each other and the sheet 30 behaves as a linear polarizer. When  $\beta = (2n-1) (\pi/4)$  with n an integer, the sheet 30 behaves as a circular polarizer. For any other values of  $\beta$ , the sheet 30 behaves as an elliptical polarizer.

[0044] In more detail, the linear polarizer layer 12 has a transmission axis T oriented at  $\theta$  and defined by the Stoke vector of Eq. (1).

$$\text{Eq. (1).} \quad \frac{1}{2} \begin{pmatrix} S_0 + S_1 \cdot \cos 2\theta + S_2 \cdot \sin 2\theta \\ S_0 \cdot \cos 2\theta + S_1 \cdot \cos^2 2\theta + S_2 \cdot \sin 2\theta \cos 2\theta \\ S_0 \cdot \sin 2\theta + S_1 \cdot \sin 2\theta \cos 2\theta + S_2 \cdot \sin^2 2\theta \\ S_3 \end{pmatrix}$$

The polarizer comprises a linear polarizer layer 12 with transmission axis T orientated at  $\theta$  and a retarder layer with its fast axis R aligned at  $\varphi$  defined by the Stoke vector of Equation 2.

Eq. (2).

$$\frac{1}{2} \begin{pmatrix} S_0 + \cos 2\theta \cdot (S_1 \cos^2 2\phi + S_2 \cos 2\phi \sin 2\phi - S_3 \sin 2\phi) + \sin 2\theta \cdot (S_1 \cos 2\phi \sin 2\phi + S_2 \sin^2 2\phi + S_3 \cos 2\phi) \\ \cos 2\theta \cdot S_0 + \cos^2 2\theta \cdot (S_1 \cos^2 2\phi + S_2 \cos 2\phi \sin 2\phi - S_3 \sin 2\phi) + \sin 2\theta \cos 2\theta \cdot (S_1 \cos 2\phi \sin 2\phi + S_2 \sin^2 2\phi + S_3 \cos 2\phi) \\ \sin 2\theta \cdot S_0 + \sin 2\theta \cos 2\theta \cdot (S_1 \cos^2 2\phi + S_2 \cos 2\phi \sin 2\phi - S_3 \sin 2\phi) + \sin^2 2\theta \cdot (S_1 \cos 2\phi \sin 2\phi + S_2 \sin^2 2\phi + S_3 \cos 2\phi) \\ S_1 \sin 2\phi - S_2 \cos 2\phi \end{pmatrix}$$

$S = \begin{pmatrix} S_0 \\ S_1 \\ S_2 \\ S_3 \end{pmatrix}$  defines the Stoke vector of light that is transmitted through the sheet

30.

[0045] Using these relationships any number of sheets 1, 10, 20, 30 configurations can be formed depending on the desired polarization properties of the sheet 1, 10, 20, 30 and the finished curved lens. In practice one may form a sheet 10, 20, 30 having desired polarization properties by predetermining the desired polarization properties of the sheet 10, 20, 30 and then forming the sheet 10, 20, 30 in such a way that the fast axis R of the retarder layer 18 is aligned at the desired angle relative to the polarization axis T of the polarizer layer 12 to achieve the desired polarization properties.

[0046] In preparation for making a curved lens, lens blanks may be prepared by cutting and removing blanks of a size and shape suited for the production of the desired lens from a composite light polarizer sheet of the invention. A preferred method of preparing a blank to be formed into a lens is shown in FIG. 4, which is a plan view of a section of sheet 40 from which blanks 42, 44 are cut and removed. The blanks 42, 44 are prepared by making a cut 46 through the section of sheet 40. The cut 46 defines the perimeter of an individual blank 42, 44 from which a blank 48 can be removed as shown in FIG. 5. Suitable methods of making the cut 46 include the use of a rolling knife cutter, a reciprocal stamping cutter, a straight edge cutting knife, a rotary die, or a laser cutter.

[0047] Individual blanks, such as blank 48 shown in FIG. 5, may be formed into lenses in the manner described below. In certain embodiments, the

blanks **48** may be subjected to one or more pre-forming treatments such as cleaning, coating, or polishing if desired.

**[0048]** A method by which a blank **48** of the invention is formed into a lens that is concave on one side and convex on the other side will now be described in connection with FIGS. **7** through **9**.

**[0049]** The forming process can be carried out by an apparatus **50** of the type shown in FIG. **7**. The apparatus includes a flexible member support **52**, a curved rigid member **54**, a mechanism for driving the curved rigid member **54** into and out of pressure-applying relationship with the flexible member support **52**, and mechanism for alternately heating and cooling the curved rigid member **54** during each pressure-applying interval.

**[0050]** The flexible member support **52** includes a fixed support **60** with the flexible member **56** attached thereto.

**[0051]** The curved rigid member **54** includes a metal member **68**, a shaft **72** operatively connected to a suitable drive mechanism, a fluid chamber **74**, a fluid inlet coupling **76**, and a fluid outlet coupling **78**. The metal member **68** has a smooth solid convex forming surface **70**.

**[0052]** The use of the metal member **68** is advantageous over conventional lens press molds such as glass molds. Due to their fragility and complexity, glass molds only allow for spherical lenses to be formed. Moreover, glass molds would not be able to withstand the higher pressures needed to form some of today's thicker and tougher curved lenses, such as the lenses of the invention. Further, metal members **68** with different shapes may be interchanged to match a desired lens curvature. Therefore, rather than just being able to form spherically curved lenses, as one would with the conventional glass molds, the invention allows for toroidally or cylindrically shaped lenses to be formed simply by selecting a suitably shaped metal member **68**.

[0053] A preferred drive mechanism includes a suitable hydraulic piston and cylinder arrangement **80** operatively connected to the curved rigid member **54** for moving the curved rigid member **54** into and out of pressure-applying relationship with the flexible member support **52**.

[0054] A preferred heating and cooling mechanism for the curved rigid member **54** includes a three-way valve **82**, a heating fluid conduit **84**, a cooling fluid conduit **86**, and fluid inlet **88** connecting the three way valve **82** to the fluid inlet coupling **76**.

[0055] In forming a curved lens, a blank **48** is placed on the flexible member **56**. The flexible member **56** and the convex forming surface **70** are then moved into contact with the blank **48** as shown in FIG. 8. As pressure is applied to the blank **48**, the flexible member **56** deforms and assumes the shape of the convex forming surface **70**.

[0056] With the application of heat and pressure, the convex forming surface **70** and the deformed flexible member **56** curve the blank **48** into a shaped lens characterized by concave and convex opposed surfaces.

[0057] The amount of pressure applied and the pressure profile may be adjusted depending on the characteristics of the blank **48**, with the temperatures of the forming surface **70** and with the curvature intended to be given to the blank **48**.

[0058] In a preferred embodiment, the pressure applied to the blank **48** is in the range of about 1.50 to about 15 MPa.

[0059] During the pressure application stage, the curved rigid member **54** is heated by passing hot fluid through the fluid chamber **74**. The forming surface **70** is continually heated at a temperature sufficient to cause deformation of the lens blank **48** material and conformation of the surfaces of blank **48** to the forming surface **70**. Application of pressure by the curved rigid member **54** onto the blank **48** therebetween causes the blank **48** to deform between the

curved rigid member **54** and the flexible member **56** producing a curved polarizer.

**[0060]**In a preferred embodiment the flexible member **56** has a thickness between about 0.5 mm and about 5.0 mm, shore hardness A between about 25 and about 70, a tensile strength between about 5 MPa and about 30 MPa, an elongation at break between about 100% and about 1000%, and a resistance to tearing between about 50 N/cm to about 1000 N/cm.

**[0061]**In some embodiments, it may also be desirable to utilize a curved rigid member **54** having a forming surface **70** corresponding to a predetermined curvature of the convex side of the lens to be formed. The convex surface of the lens, formed against the flexible member **56**, may serve as the outer surface of an eyeglass lens. A suitable radius of curvature for the forming surface **70** is about 50 to about 270 mm, or about 65 to about 90 mm. In a particular embodiment, the forming surface **70** is cylindrically shaped and has a radius of curvature of about 52.3mm.

**[0062]**The temperature sufficient to cause the blank **48** to deform may vary with the chemical composition of the blank's **48** composite structure. A preferred heating temperature range is between about 70°C to about 200°C. Another preferred heating range is between about 90°C to about 110°C. One particular preferred heating temperature is about 105°C.

**[0063]**In some cases it may be helpful to pre-heat the blank **48** before applying pressure. Suitable pre-heating temperatures are within the range of about 20°C to about 150°C.

**[0064]**The temperature of the forming surface **70** of the curved rigid member **54** can be controlled by the passage of heated fluid and cooled fluid, as described previously. The curved rigid member **54** is preferably preheated, prior to placement of the blank therebetween, to the desired forming temperature for a heating cycle sufficient to provide the desired shaped lens. The desired forming temperature is maintained for a duration sufficient to

effect desired lens formation. Although not limiting, a suitable duration is between about 80 to about 90 seconds. Thereafter, the temperature of the forming surface **70** is reduced by passing a cooling fluid, through the fluid chamber **74** of the curved rigid member **54**. The cooling fluid is passed through the curved rigid member **54** for a time sufficient to cool the formed lens. Although not limiting, a suitable cooling duration is about 30 seconds. Cooling temperatures from about 20°C to about 35°C provide good results, but other cooling temperatures are also contemplated.

**[0065]** Hot fluid is supplied to the curved rigid member **54** through the heating fluid conduit **84** and the relatively cool fluid is supplied through the cooling fluid conduit **86**. During the heating cycle, the valve **82** opens a connecting passage between the heating fluid conduit **84** and the inlet **76** and closes the cooling fluid conduit **86**. During the cooling cycle, the valve **82** opens a connecting passage between the cooling fluid conduits **86** and the inlet **76** and closes the heating fluid conduit **84**. The transition from the heating cycle to the cooling cycle is carried out by operating the valve **82** to mix cool fluid with the hot fluid until the hot fluid is completely displaced by cool fluid. Transition from the cooling cycle to heating cycle is carried out by reversing the operation.

**[0066]** After the cooling operation, the flexible member support **52** and the curved rigid member, **54** are separated to relieve the pressure on the formed lens **90** and permit its removal, as shown in FIG. **9**. If the formed lens **90** adheres to one of the members **52**, **54**, it may be removed by applying a stream of compressed air.

**[0067]** One or more coatings can be applied on the concave and/or convex surfaces of the formed lens **90** using conventional vacuum deposition techniques. The inventors discovered that applying an anti-reflective coating to the convex and concave surfaces of a circular polarizer lens of the invention can significantly improve the transmittance % of the finished circular polarizer lens.

**[0068]** The method described above can also include repeating each of these steps using a series of curved rigid members **54** for the shaping of blanks **48** to each of a series of solid convex lens surfaces, each of such surfaces having a different curvature within a desired range of curvatures, thus providing a series of lenses, each having a different solid convex surface within a desired range of curvatures.

**[0069]** A lens of the invention may also gradually be shaped to a desired form by repeating the steps and gradually increasing the curvature of the curved rigid member **54** prior to each repetition. This can be accomplished using a series of curved rigid members **54** with each set in the series having an increased curvature relative to the prior set.

**[0070]** The shape of a formed lens of the invention will substantially correspond to the shape of the forming surface **70**. Accordingly, different shaped forming surface **70** can be used to form lenses with different curvatures. For example, a pair of spherically shaped, a pair of cylindrically shaped, or a pair of toroidally shaped forming surface **70** can be used to form spherically curved, cylindrically curved, and toroidally curved light polarizer lenses, respectively.

**[0071]** For spherically, toroidally, and cylindrically curved lenses, the shape of the lens, along the first principal meridian corresponds substantially to the relationship  $r_1 = (n-1)/D_1$ , the shape of the lens along the second principal meridian, perpendicular to the first principal meridian, corresponds substantially to the relationship  $r_2 = (n-1)/D_2$ ,  $n$  represents the index of refraction of the blank **48**,  $D_1$  and  $D_2$  are the intended lens curvatures,  $r_1$  and  $r_2$  are the radii of curvature of each principal meridian of the solid convex forming surface **70**. In preferred embodiments,  $r_1$  and  $r_2$  are typically in the range of about 1 to about 10 diopters. To form a spherically curved lens  $r_1$  equals  $r_2$ . To form a toroidally curved lens  $r_1$  is different from  $r_2$ . To form a cylindrically curved lens,  $r_1$  is different from  $r_2$  and  $r_2$  is about 0 diopter. The



lens thickness is typically in the range of about 0.2 mm to about 2.5 mm. This relationship can also apply to other shaped curvatures.

**[0072]** FIGS. 10A-C depict a formed spherical lens **90'**, a formed toroidal lens **90''**, and a formed cylindrical lens **90'''**, respectively. The curvature of each lens **90'**, **90''**, **90'''** is characterized by a first radius of curvature  $r_1$  and a second radius of curvature  $r_2$ . The lines along which  $r_1$  and  $r_2$  are determined are indicated. For the spherically curved lens **90'**,  $r_1$  equals  $r_2$ . For the toroidally curved lens **90''**,  $r_1$  is different from  $r_2$ . For the cylindrically curved lens **90'''**,  $r_1$  is different from  $r_2$  and  $r_2$  is about 0 diopter.

**[0073]** Another object of the invention is to provide polarized eyewear that includes two lenses of the invention. Referring to FIG. 11, the eyewear **100** includes an eyeglass frame **102**, a first lens **104** and a second lens **106**. The lenses **104**, **106** may be the same or different, depending on the desired use of the eyewear. For the manufacture of linear polarized eyewear, the first lens **104** and second lens **106** are preferably identical. The sheet used for these lenses will have a stoke vector as described in Equation 1 with the polarizer axis orientated parallel to the horizontal ( $\theta=0$ ). In some preferred examples for stereoscopic use, both lenses are made of linear polarizer sheet having a stoke vector as described in Equation 1 with the polarizer axis of the first lens **104** orientated at  $\theta$  and the polarizer axis of the second lens **106** orientated at  $\theta+\pi/2$ . In a further preferred example for stereoscopic use, the sheet material comprises a retarder layer **18** and has a Stoke vector as described in Equation 2. The first lens **104** has its polarizer axis **T** orientated at  $\theta$  and fast axis of the retarder **R** orientated at  $\varphi = \theta + \beta$  and the second lens **106** has its polarizer axis **T** orientated at  $\theta$  and fast axis of the retarder **R** orientated at  $\varphi = \theta - \beta$ .

## EXAMPLES

[0074] In this section, certain illustrative embodiments of the invention are described. These are provided by way of example only and, therefore, do not limit the scope of the invention.

#### EXAMPLE 1

##### PREPARATION OF A LENS OF THE INVENTION

[0075] A spherically shaped linear polarizer lens of the invention was prepared using the method and apparatus described above. The structure of the lens 112 will be better understood by referring to FIG. 12. The lens 112 was formed from a total of six layers of material including a polarizer layer 12, a first polymeric layer 14, a second polymeric layer 16, a third polymeric layer 118, a first hard coat layer 114 and a second hard coat layer 116. The lens has its maximum thickness in the central portion. The materials used to make the lens 112, the properties of the platens, and the forming parameters are all specified in TABLE 1.

**TABLE 1. Materials and Parameters Used to Form an Exemplary Lens of the Invention**

Lens Materials	Layer 1 (114)		hardcoat
	Layer 2 (118)		cellulose triacetate
	Layer 3 (16)		cellulose triacetate
	Layer 4 (12)		stretched PVA with iodine
	Layer 5 (14)		cellulose triacetate
	Layer 6 (116)		hardcoat
	Thickness of blank material		0.6mm
Platens	Material	Curved rigid member 54	steel
		flexible member 56	elastomer
	Radius	r1	52.3 mm
		r2	0.0 mm
Forming Parameters	Temperatures	pre-heating	50-70°C
		heating	90-100°C

		cooling	20-35°C
	Pressure		5-7 MPa

EXAMPLE 2

IMPROVEMENT OF TRANSMITTANCE USING ANTI-REFLECTIVE COATINGS ON CIRCULAR POLARIZED LENSES

[0076] Circular polarizer lenses of the invention were coated on both the solid convex and flexible concave surfaces with an anti-reflective coating in order to determine whether an anti-reflective coating can improve the transmittance % within the wavelength range of 280 to 700 nm, which includes the visible light spectrum. The structure of a circular polarized lens including an antireflective coating will be better understood with reference to FIG. 13 in which the lens 120 includes a polarizer layer 12, a first polymeric layer 14, a second polymeric layer 16, a retarder layer 18, a first antireflective coating layer 122 and a second antireflective coating layer 124.

[0077] TABLE 2 shows results of typical transmittance % improvement.

**TABLE 2. Transmittance Improvement Data**

Anti-reflective coating applied?	Cross polarizer transmittance (%)	Parallel polarizer transmittance (%)
NO	0.02	82
YES	0.03	90

[0078] The application of an anti-reflective coating is used regularly in eyewear products. For both sunglass and corrective eyewear it is applied to the back of the lens to minimize disturbing back reflections on the lens from light sources situated behind the wearer. For corrective eyewear, it is also applied at the front of the lens for cosmetic reasons, namely in order to prevent reflections from the front of the lenses, making the eyewear less noticeable.

**[0079]** We found that when anti-reflective coatings are applied to stereoscopic eyewear as described in this example, the coating advantageously and significantly increases the transmittance of the light the lens is designed to transmit without increasing the transmittance of the light the lens is designed to block. In this case, the lenses were designed to maximize the parallel polarizer transmittance, while minimizing the cross-polarizer transmittance. The results show that the anti-reflective coating allowed us to increase by the parallel polarizer transmittance by 8% with minimal increase in the cross-polarizer transmittance. This is especially important to 3D projection operators, such as cinema operators, since a significant amount of light is lost in the 3D display. The ability of the eyewear to transmit more light allows the operators to use less powerful light sources resulting in significant operational cost savings.

**[0080]** The present invention has been described hereinabove with reference to the accompanying drawings, in which preferred embodiments of the invention are shown. Unless otherwise defined, all technical and scientific terms used herein are intended to have the same meaning as commonly understood in the art to which this invention pertains and at the time of its filing. Although various methods and materials similar or equivalent to those described herein can be used in the practice or testing of the present invention, suitable methods and materials are described. The skilled should understand that the methods and materials used and described are examples and may not be the only ones suitable for use in the invention.

**[0081]** Accordingly, this invention may be embodied in many different forms and should not be construed as limited to the illustrated embodiments set forth herein. The invention has been described in some detail, but it will be apparent that various modifications and changes can be made within the spirit and scope of the invention as described in the foregoing specification and as defined in the appended claims.

**THAT WHICH IS CLAIMED IS:**

1. A method of making a formed lens, the method comprising:
  - obtaining a lens blank comprising, in superposed relation, a linear polarizer layer laminated together with a plurality of polymeric layers, the linear polarizer layer having a polarization axis;
  - heating and applying a pressure to the lens blank by pressing the lens blank between a curved rigid member and a flexible member, thereby causing the flexible member to assume the shape of the curved rigid member; and
  - maintaining the higher pressure for a time sufficient to allow the lens blank to conform to the shape of the curved rigid member and the flexible member.
2. The method of claim 1, wherein heating is conducted at about 70°C to about 200°C.
3. The method of claim 1, wherein the pressure is about 1.5 MPa to about 15 MPa.
4. The method of claim 1, further comprising cooling the lens blank while maintaining the pressure.
5. The method of claim 4, wherein cooling is conducted at about 20°C to about 90°C.

6. The method of claim 1, further comprising, preheating the lens blank to a temperature of about 20°C to about 150°C prior to applying the pressure.
7. The method of claim 1, wherein at least one of the polymeric layers is an optical wave retarder having a fast axis and the fast axis is aligned at an angle relative to the polarizer axis.
8. The method of claim 7, wherein the angle renders the lens a linear polarizer.
9. The method of claim 7, wherein the angle renders the lens an elliptical polarizer.
10. The method of claim 7, wherein the angle renders the lens a circular polarizer.
11. The method of claim 10, further comprising coating a concave surface and a convex surface of the formed lens with an anti-reflective coating.
12. The method of claim 11, wherein the formed lens has a parallel polarizer transmittance equal to or greater than 90% and a cross polarizer transmittance equal to or less than 0.5%

13. The method of claim 1, wherein the shape of the curved rigid member produces a spherically shaped lens having a first radius of curvature and a second radius of curvature perpendicular to the first radius of curvature, wherein the first radius of curvature and second radius of curvature are equal.

14. The method of claim 1, wherein the shape of the curved rigid member produces a toroidally shaped lens having a first radius of curvature and a second radius of curvature perpendicular to the first radius of curvature, wherein the first radius of curvature and second radius of curvature are not equal.

15. The method of claim 1, wherein the shape of the curved rigid member produces a cylindrically shaped lens having a first radius of curvature and a second radius of curvature perpendicular to the first radius of curvature, wherein the first radius of curvature is non-zero and the second radius of curvature is zero.

16. An eyeglass lens made according to the method of claim 1.

17. A method of making a formed lens, the method comprising:

obtaining a lens blank comprising, in superposed relation, a linear polarizer layer laminated together with a plurality of polymeric layers, the linear polarizer layer having a polarization axis;

heating the lens blank to a forming temperature by pressing the lens blank at a pressure between a curved rigid member and a flexible member, the curved rigid member being at the forming temperature;

maintaining the pressure while heating at the forming temperature for allowing the lens blank to conform to the shape of the curved rigid member;

reducing the temperature to a reduced temperature while maintaining the pressure for allowing the lens blank to become a rigid lens having a convex side and a concave side; and

removing the rigid lens from between the curved rigid member and flexible member.

**18.** The method of claim **17**, wherein the forming temperature is about 70°C to about 200°C.

**19.** The method of claim **17**, wherein the pressure is about 1.5 MPa to about 15 MPa.

**20.** The method of claim **17**, wherein the reduced temperature is about 20°C to about 90°C.

**21.** The method of claim **17**, further comprising, preheating the lens blank to a temperature of about 20°C to about 150°C prior to applying the pressure.

**22.** The method of claim **17**, wherein at least one of the polymeric layers is an optical wave retarder having a fast axis and the fast axis is aligned at an angle relative to the polarizer axis.



**23.** The method of claim **22**, wherein the angle renders the lens a linear polarizer.

**24.** The method of claim **22**, wherein the angle renders the lens an elliptical polarizer.

**25.** The method of claim **22**, wherein the angle renders the lens a circular polarizer.

**26.** The method of claim **25**, further comprising coating a concave surface and a convex surface of the formed lens with an anti-reflective coating.

**27.** The method of claim **26**, wherein the formed lens has a parallel polarizer transmittance equal to or greater than 90% and a cross polarizer transmittance equal to or less than 0.5%.

**28.** The method of claim **17**, wherein the shape of the solid convex member produces a spherically shaped lens having a first radius of curvature and a second radius of curvature perpendicular to the first radius of curvature, wherein the first radius of curvature and second radius of curvature are equal.

**29.** The method of claim **17**, wherein the shape of the solid convex member and flexible concave member produce a toroidally shaped lens having a first radius of curvature and a second radius of curvature perpendicular to the first

radius of curvature, wherein the first radius of curvature and second radius of curvature are not equal.

**30.** The method of claim **17**, wherein the shape of the solid convex member and flexible concave member produce a cylindrically shaped lens having a first radius of curvature and a second radius of curvature perpendicular to the first radius of curvature, wherein the first radius of curvature is non-zero and the second radius of curvature is zero.

**31.** An eyeglass lens made according to the method of claim **17**.

**32.** A method of making eyewear, the method comprising:

(a) obtaining a first lens and a second lens, the first lens and second lens comprising, in superposed relation, a linear polarizer layer laminated together with a plurality of polymeric layers, the linear polarizer layer having a polarization axis, the first lens and second lens being formed from lens blanks into a desired shape according to the following steps:

(i) heating and applying a pressure to the lens blanks separately by pressing the lens blanks between a curved rigid member and a flexible member, thereby causing the flexible member to assume the shape of the curved rigid member;

(ii) maintaining the higher pressure for a time sufficient to allow the lens blank to conform to the shape of the curved rigid member and the flexible member; and

(b) placing the first lens and second lens into an eyeglass frame.

1/7

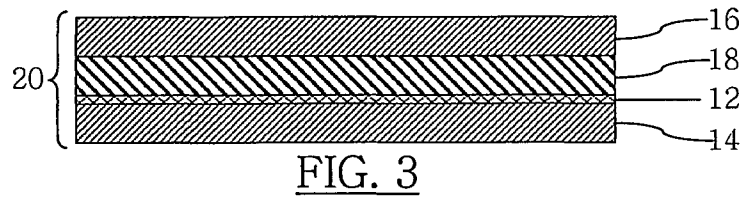
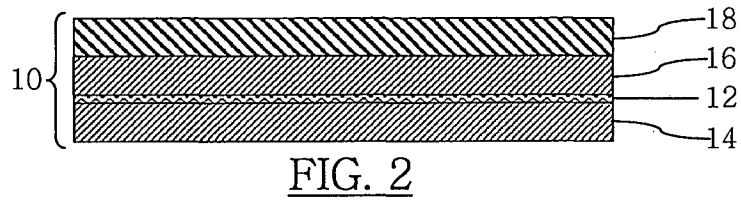
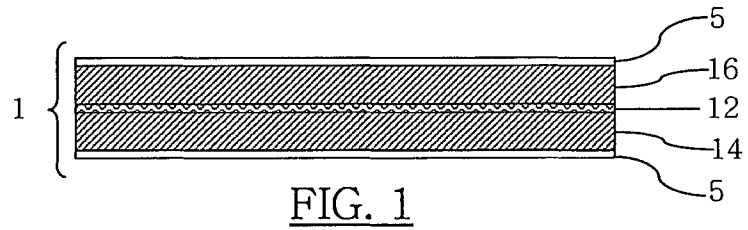

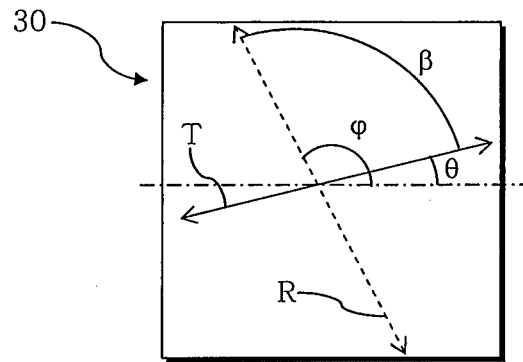

FIG. 4

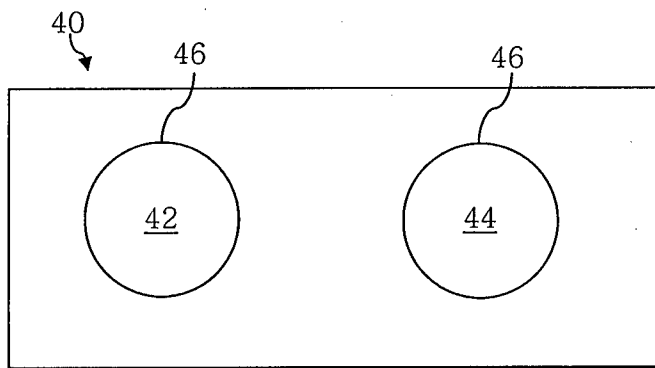

FIG. 5

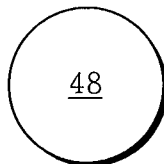

FIG. 6

3/7

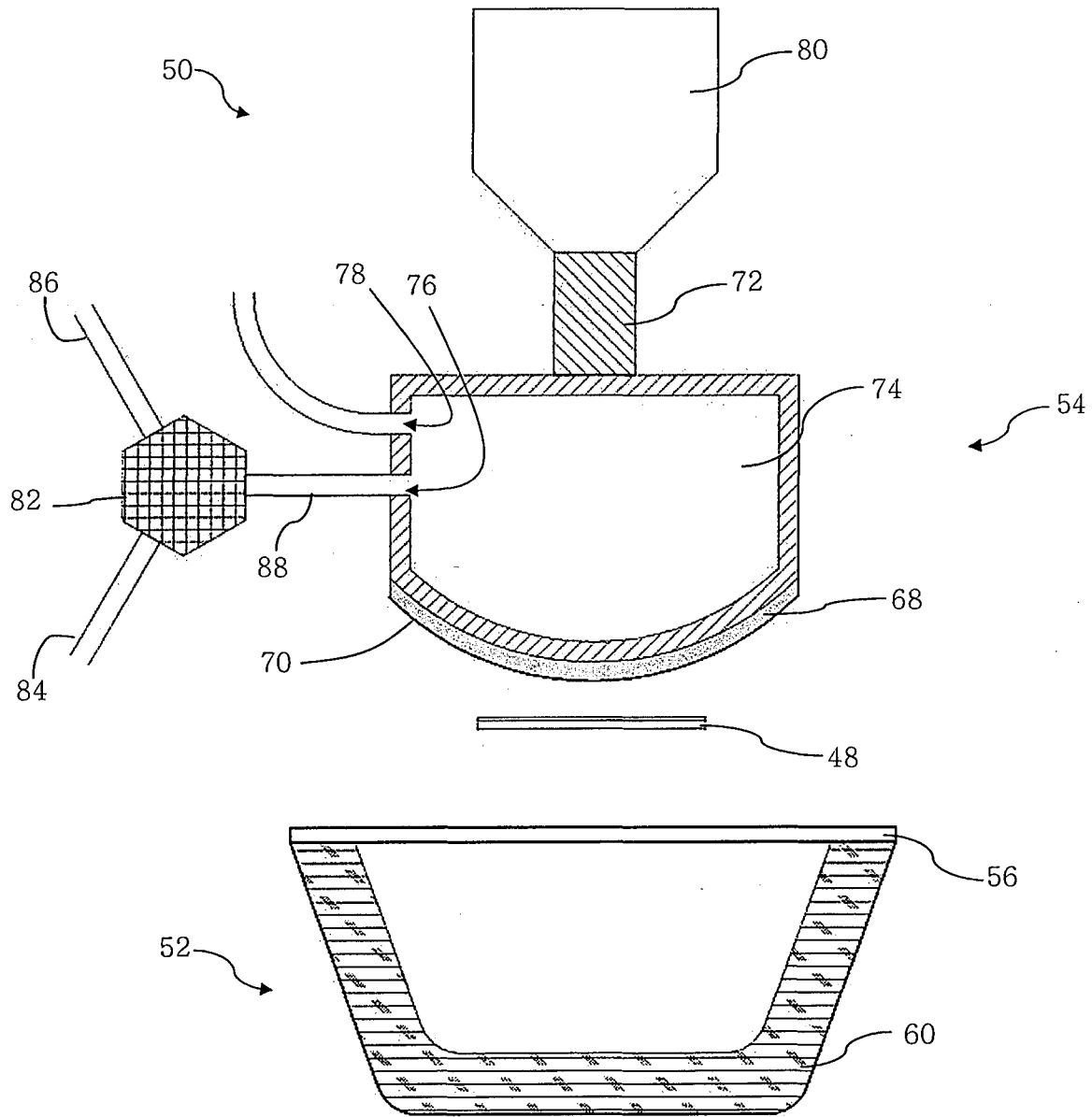

FIG. 7

4/7

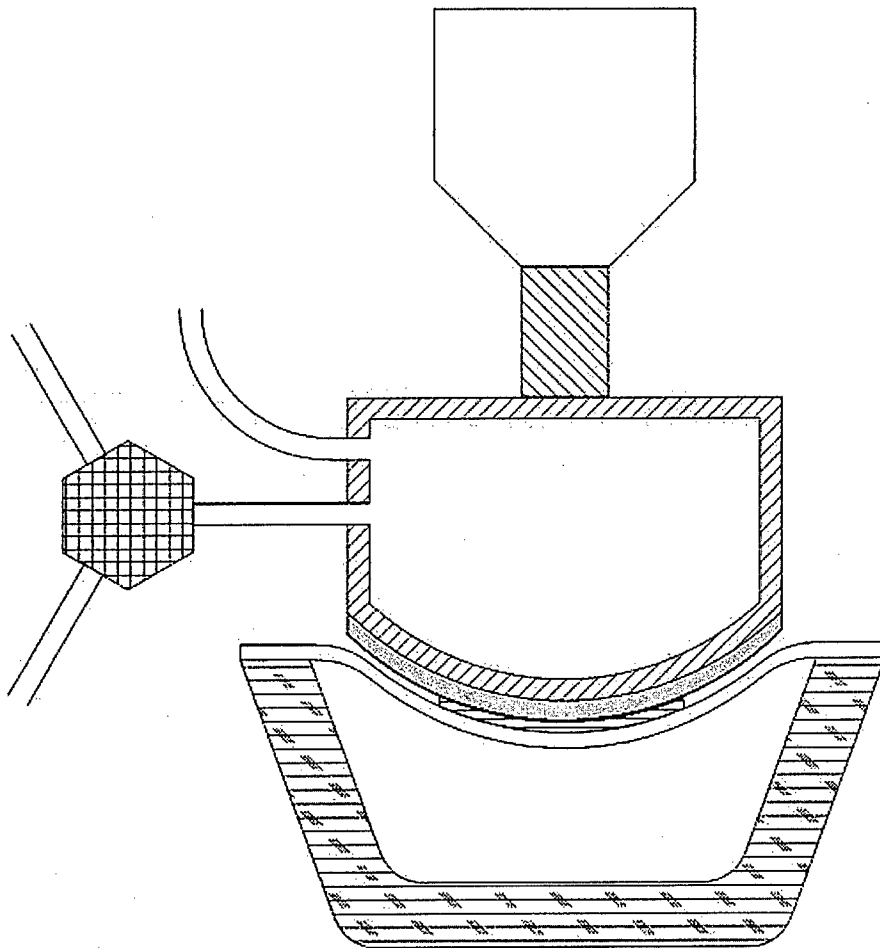

FIG. 8

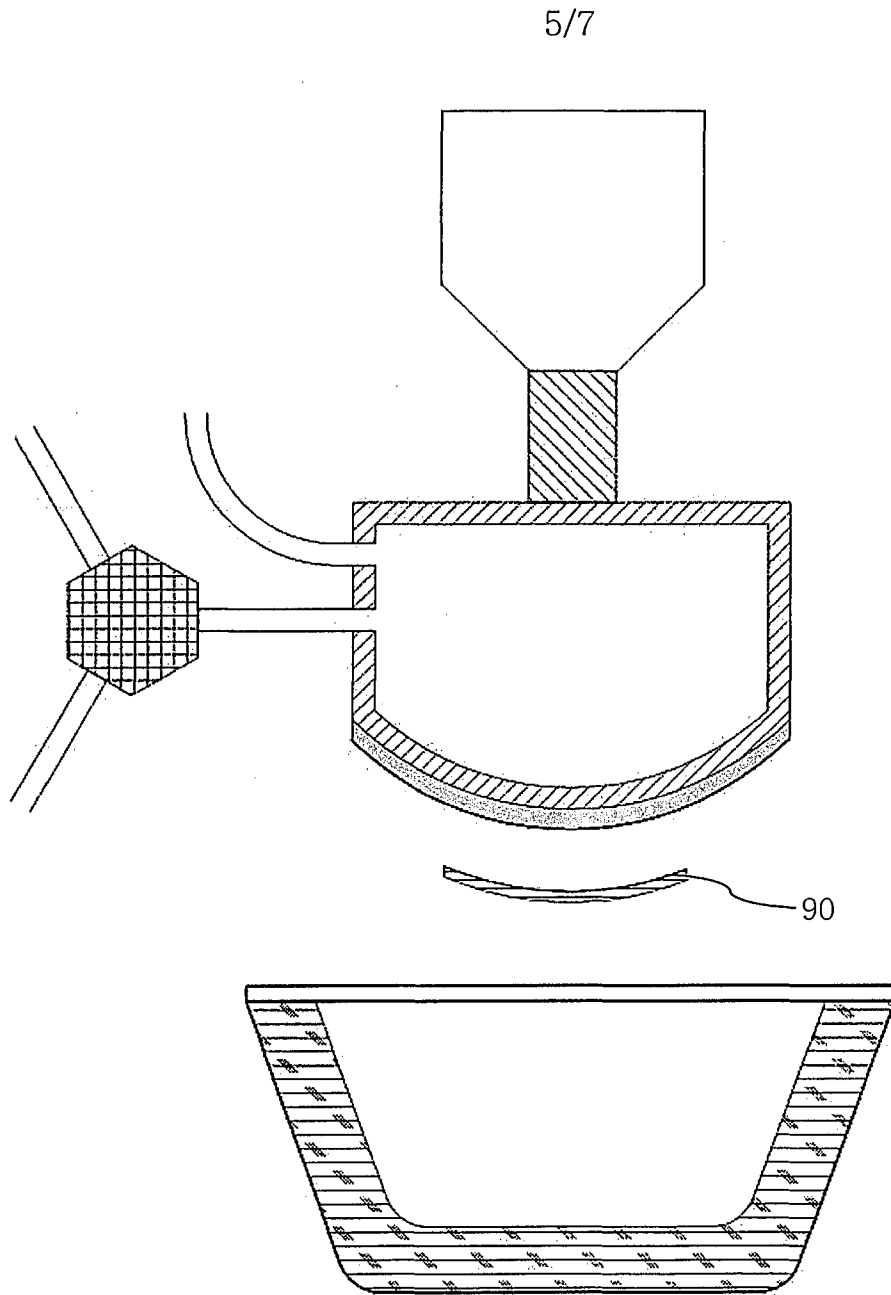
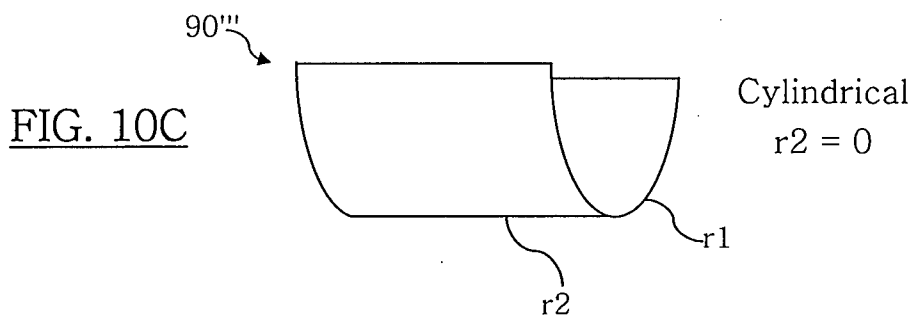
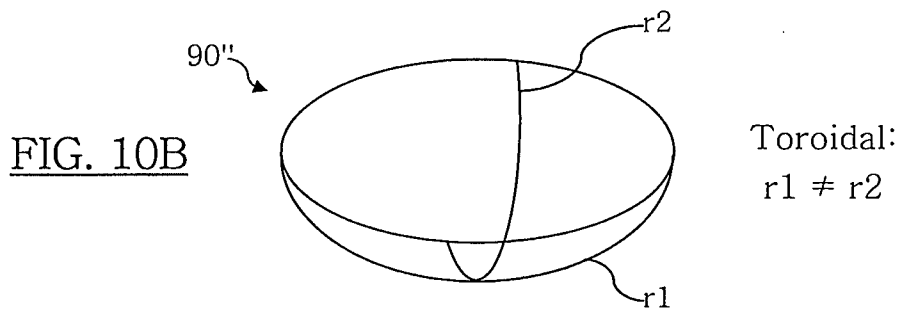
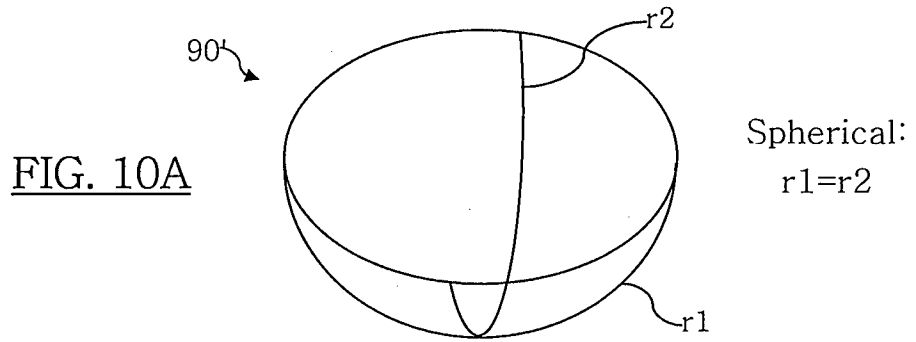

FIG. 9





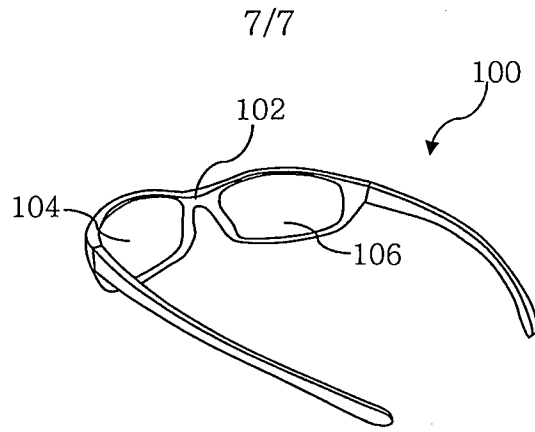

FIG. 11

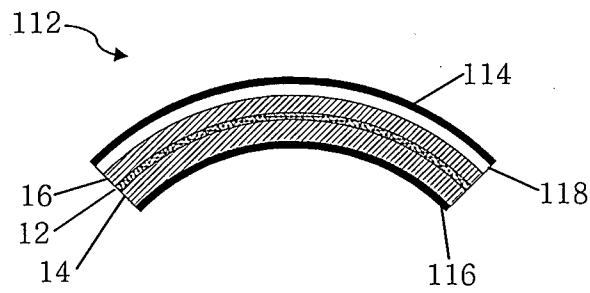

FIG. 12

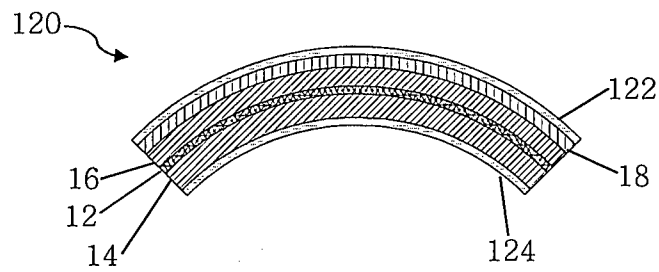

FIG. 13