



US00D781514S

(12) **United States Design Patent**  
**Perin et al.**

(10) **Patent No.:** **US D781,514 S**  
(45) **Date of Patent:** **\*\* Mar. 14, 2017**

- (54) **VACUUM CLEANER NOZZLE HOOD**
- (71) Applicant: **Electrolux Home Care Products, Inc.**,  
Charlotte, NC (US)
- (72) Inventors: **Jamie Perin**, Charlotte, NC (US); **Saba Rizzi**,  
Charlotte, NC (US)
- (73) Assignee: **Electrolux Home Care Products, Inc.**,  
Charlotte, NC (US)
- (\*\*) Term: **14 Years**
- (21) Appl. No.: **29/497,851**
- (22) Filed: **Jul. 29, 2014**
- (51) **LOC (10) Cl.** ..... **15-05**
- (52) **U.S. Cl.**  
USPC ..... **D32/32**
- (58) **Field of Classification Search**  
USPC ..... D32/25, 31-33  
CPC ..... A47L 9/02; A47L 9/06; A47L 5/28; A47L  
5/24; A47L 11/4044; E04H 4/1654; E04H  
4/34  
See application file for complete search history.

- 6,823,559 B2 11/2004 Kaffenberger et al.
- D501,283 S 1/2005 Carr et al.
- D506,048 S \* 6/2005 Downey ..... D32/32
- D524,498 S \* 7/2006 Luebbering ..... D32/32
- D536,495 S \* 2/2007 Porter ..... D32/32
- D537,587 S 2/2007 Scheifele et al.
- D546,510 S 7/2007 Parr et al.

(Continued)

*Primary Examiner* — Ruth McInroy  
(74) *Attorney, Agent, or Firm* — RatnerPrestia

(57) **CLAIM**

The ornamental design for a vacuum cleaner nozzle hood, as shown and described.

**DESCRIPTION**

FIG. 1 is a top front isometric view of a vacuum cleaner nozzle hood showing our new design.

FIG. 2 is a top rear isometric view of the vacuum cleaner nozzle hood shown in FIG. 1.

FIG. 3 is bottom front isometric view of the vacuum cleaner nozzle hood shown in FIG. 1.

FIG. 4 is a top plan view of the vacuum cleaner nozzle hood shown in FIG. 1.

FIG. 5 is a right side elevation view of the vacuum cleaner nozzle hood shown in FIG. 1.

FIG. 6 is a left side elevation view of the vacuum cleaner nozzle hood shown in FIG. 1.

FIG. 7 is a front elevation view of the vacuum cleaner nozzle hood shown in FIG. 1; and,

FIG. 8 is a rear elevation view of the vacuum cleaner nozzle hood shown in FIG. 1.

In the drawings, the dash-dot broken lines immediately adjacent the shaded surfaces represent the boundary of the claimed design, and the dash-dot broken lines are not claimed. The remaining broken lines indicate environmental structure that forms no part of the claimed design.

**1 Claim, 7 Drawing Sheets**

(56) **References Cited**

U.S. PATENT DOCUMENTS

2,904,816	A	2/1956	Skolfield	
2,904,817	A	9/1959	Brennan	
3,005,224	A	10/1961	Magarian	
4,392,271	A	7/1983	Speke	
5,054,157	A	10/1991	Werner et al.	
5,207,498	A	5/1993	Lawrence et al.	
5,467,501	A	11/1995	Speke	
D381,780	S *	7/1997	Summers	D32/33
5,893,195	A	4/1999	Jung	
6,490,755	B2	12/2002	Paterson et al.	
D473,687	S *	4/2003	Kaffenberger	D32/33
D487,602	S	3/2004	Roberts et al.	
D495,106	S *	8/2004	Leyden	D32/32

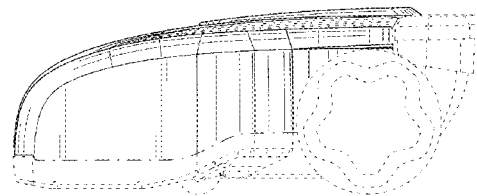
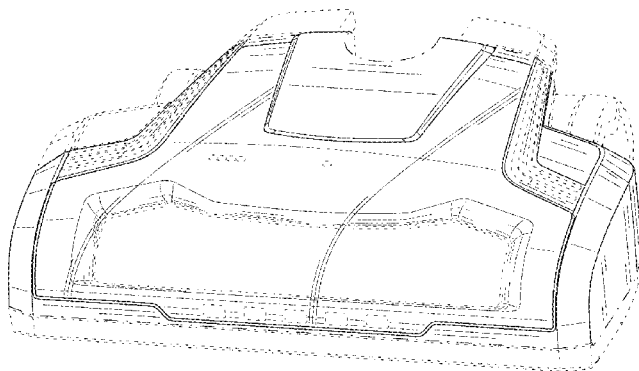

(56)

**References Cited**

U.S. PATENT DOCUMENTS

D549,906	S	8/2007	Rosenzweig	
D566,354	S	4/2008	Paredes et al.	
D566,355	S	4/2008	Paredes et al.	
D575,467	S	8/2008	Paredes et al.	
7,441,307	B2	10/2008	Smith	
D594,612	S *	6/2009	Umeda .....	D32/32
7,634,836	B2	12/2009	Lee	
D619,315	S *	7/2010	Ayers .....	D32/32
D621,564	S *	8/2010	Kaffenberger .....	D32/32
D655,468	S *	3/2012	Karsan .....	D32/33
8,214,966	B2	7/2012	Steffen et al.	
D667,184	S *	9/2012	Chu .....	D32/33
8,387,207	B2	3/2013	Dimbylow et al.	
D720,104	S *	12/2014	Santiago .....	D32/32
D730,003	S *	5/2015	Cheon .....	D32/33
2006/0076035	A1	4/2006	McGee et al.	

\* cited by examiner

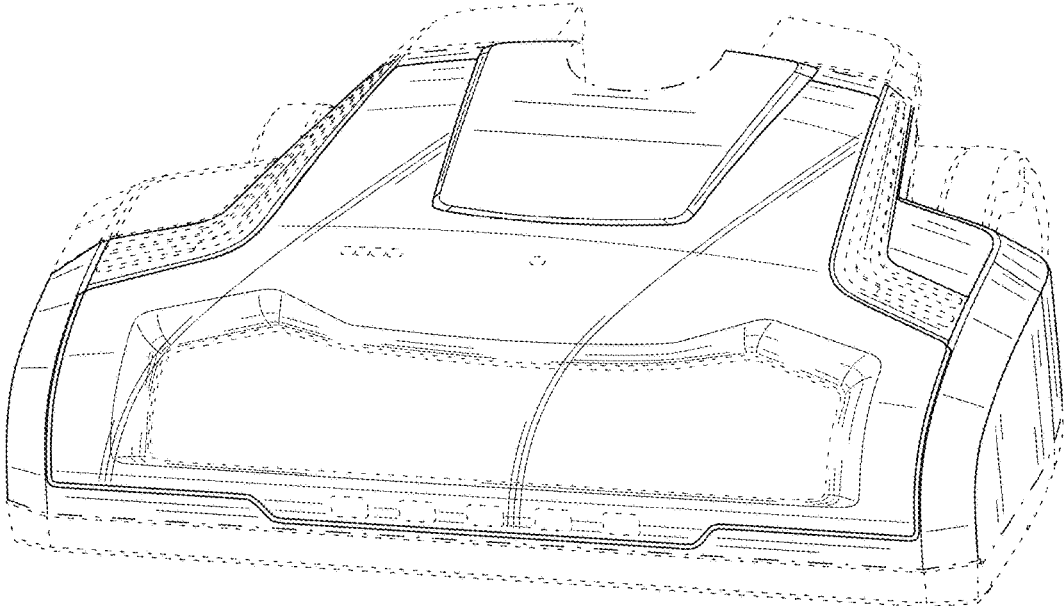

FIG. 1

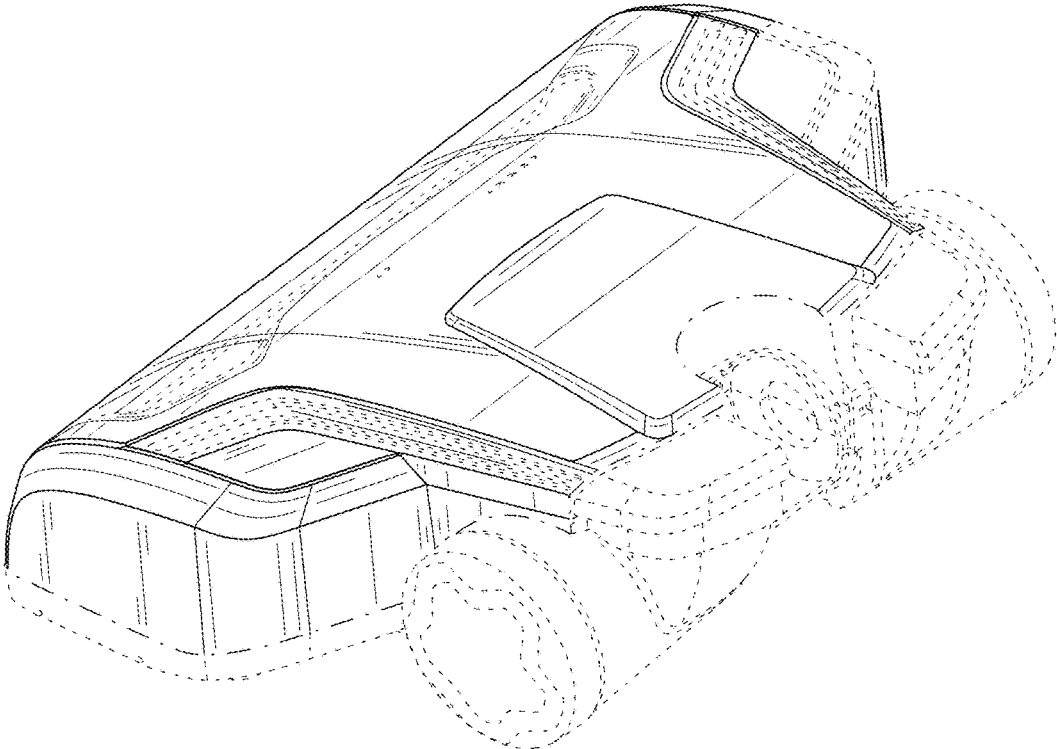

FIG. 2

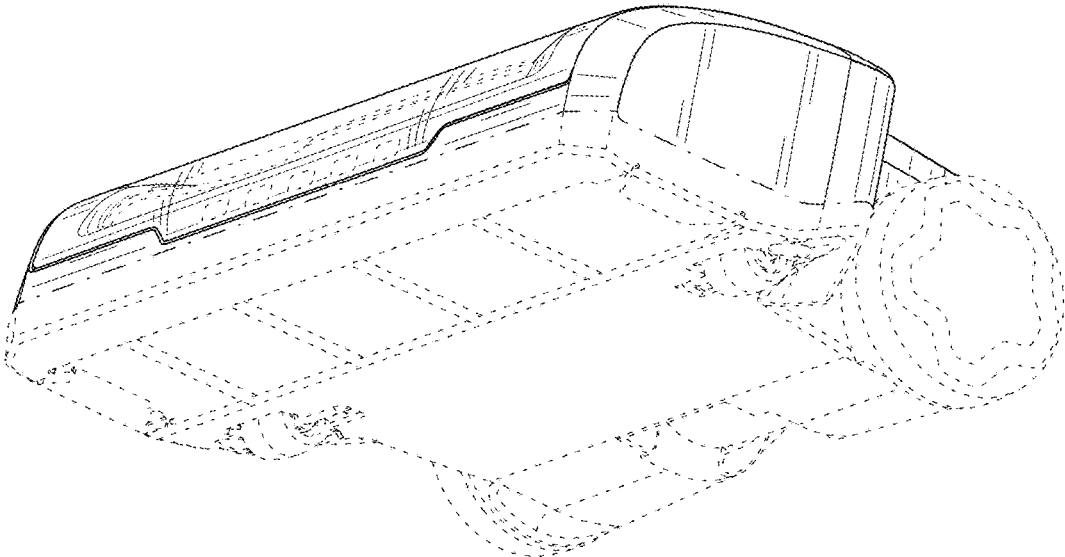

FIG. 3

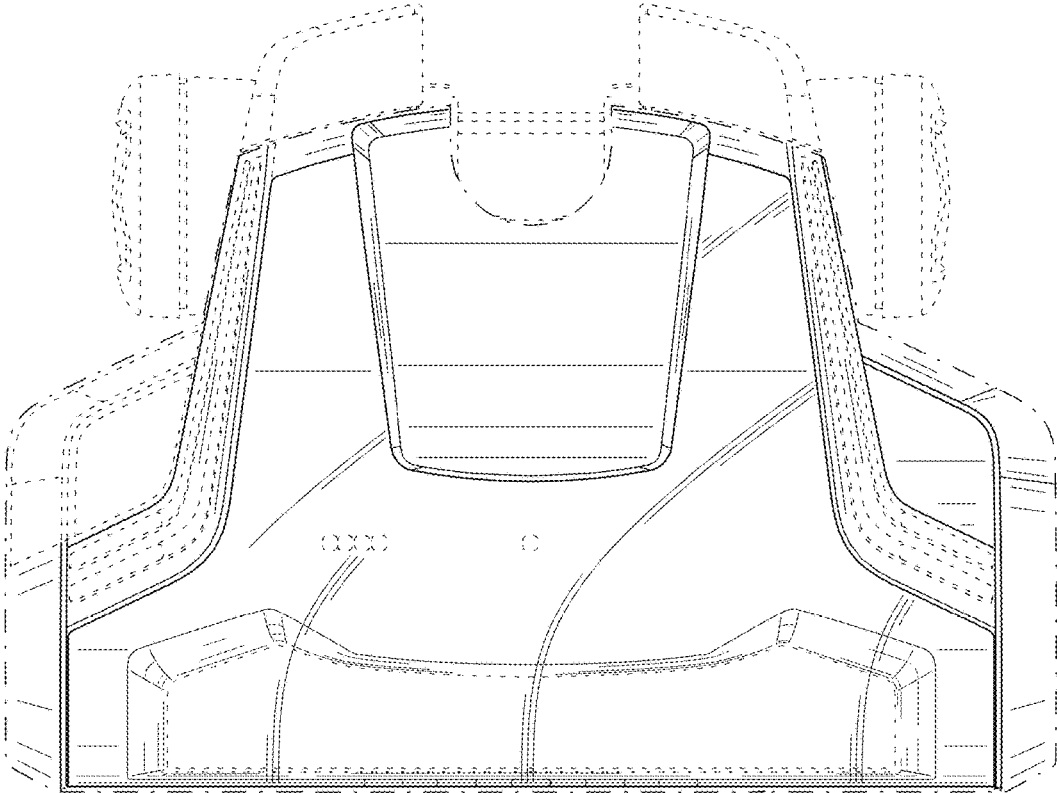

FIG. 4

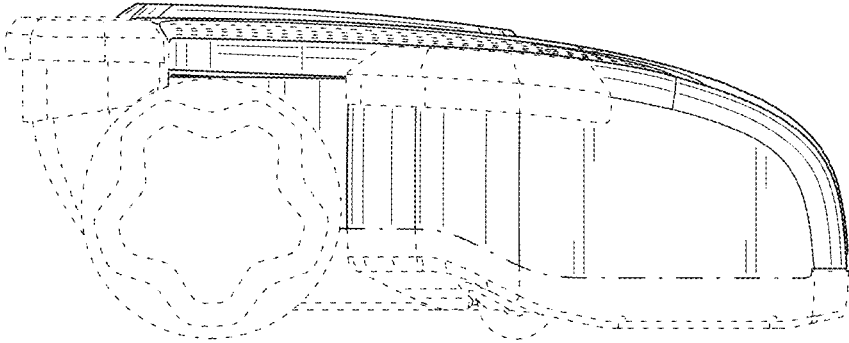

FIG. 5

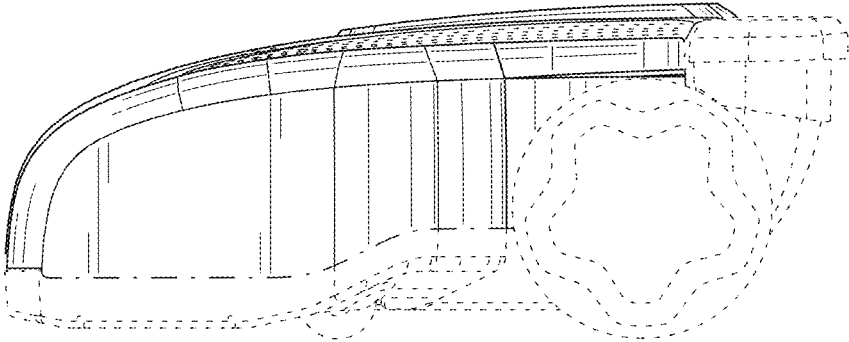

FIG. 6

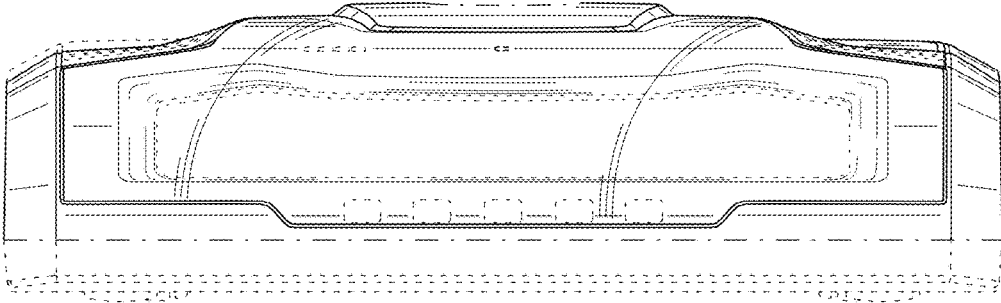

FIG. 7



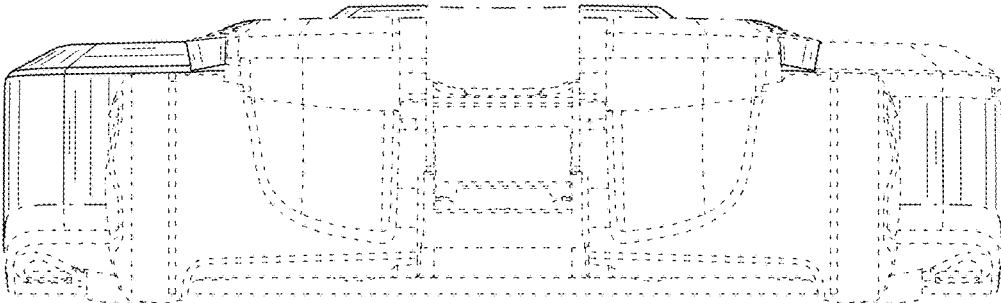

FIG. 8