



(51) International Patent Classification:
A63B 53/00 (2015.01) A63B 60/00 (2015.01)

(21) International Application Number:
PCT/US2020/044782

(22) International Filing Date:
03 August 2020 (03.08.2020)

(25) Filing Language: English

(26) Publication Language: English

(30) Priority Data:
62/881,463 01 August 2019 (01.08.2019) US
63/046,505 30 June 2020 (30.06.2020) US

(71) Applicant: **KARSTEN MANUFACTURING CORPORATION** [US/US]; 2201 West Desert Cove, Phoenix, Arizona 85029 (US).

(72) Inventors: **WILLMOTT, James, D.**; 2201 West Desert Cove, Phoenix, Arizona 85029 (US). **HENRIKSON, Erik, M.**; 2201 West Desert Cove, Phoenix, Arizona 85029 (US).

HIGDON, David, A.; 2201 West Desert Cove, Phoenix, Arizona 85029 (US). **BRUBAKER, Cole, D.**; 2201 West Desert Cove, Phoenix, Arizona 85029 (US).

(74) Agent: **JENNY, Paul, A.**; 2201 West Desert Cove, Phoenix, Arizona 85029 (US).

(81) Designated States (unless otherwise indicated, for every kind of national protection available): AE, AG, AL, AM, AO, AT, AU, AZ, BA, BB, BG, BH, BN, BR, BW, BY, BZ, CA, CH, CL, CN, CO, CR, CU, CZ, DE, DJ, DK, DM, DO, DZ, EC, EE, EG, ES, FI, GB, GD, GE, GH, GM, GT, HN, HR, HU, ID, IL, IN, IR, IS, IT, JO, JP, KE, KG, KH, KN, KP, KR, KW, KZ, LA, LC, LK, LR, LS, LU, LY, MA, MD, ME, MG, MK, MN, MW, MX, MY, MZ, NA, NG, NI, NO, NZ, OM, PA, PE, PG, PH, PL, PT, QA, RO, RS, RU, RW, SA, SC, SD, SE, SG, SK, SL, ST, SV, SY, TH, TJ, TM, TN, TR, TT, TZ, UA, UG, US, UZ, VC, VN, WS, ZA, ZM, ZW.

(84) Designated States (unless otherwise indicated, for every kind of regional protection available): ARIPO (BW, GH, GM, KE, LR, LS, MW, MZ, NA, RW, SD, SL, ST, SZ, TZ,

(54) Title: GOLF CLUB HEADS WITH A MULTI-MATERIAL STRIKING SURFACE

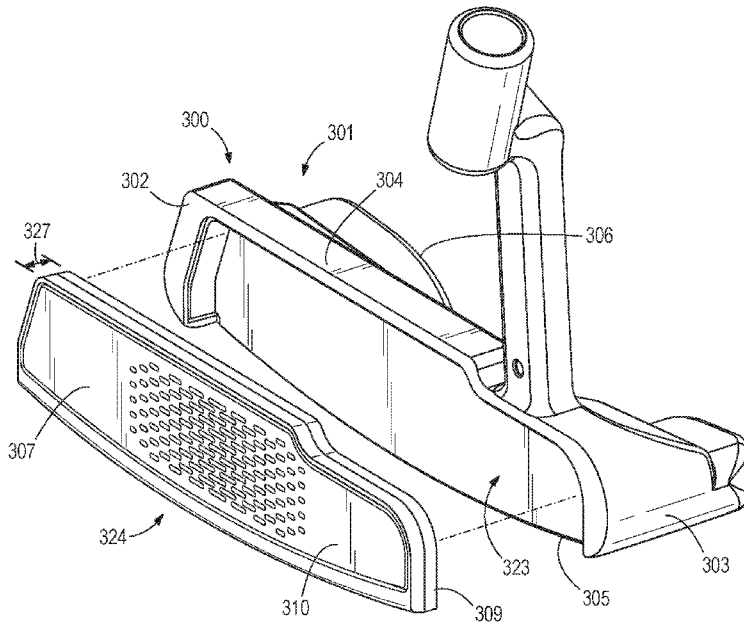

FIG. 10

(57) Abstract: Embodiments of putter-type golf club head comprising a striking surface capable of achieving consistent ball speeds across the striking surface to account for various ball impact locations are described herein. The striking surface has at least two materials that differs in concentration away from the geometric center of the striking surface to provide this consistency. Consistent (or uniform) ball speed is achieved throughout the striking surface as the portion of the golf ball that contacts the striking surface interacts with at least two materials having a differing material characteristic.



UG, ZM, ZW), Eurasian (AM, AZ, BY, KG, KZ, RU, TJ, TM), European (AL, AT, BE, BG, CH, CY, CZ, DE, DK, EE, ES, FI, FR, GB, GR, HR, HU, IE, IS, IT, LT, LU, LV, MC, MK, MT, NL, NO, PL, PT, RO, RS, SE, SI, SK, SM, TR), OAPI (BF, BJ, CF, CG, CI, CM, GA, GN, GQ, GW, KM, ML, MR, NE, SN, TD, TG).

Published:

— *with international search report (Art. 21(3))*

GOLF CLUB HEADS WITH A MULTI-MATERIAL STRIKING SURFACE

TECHNICAL FIELD

[0001] This disclosure relates generally to golf club heads and more particularly to a putter-type golf club head with a multi-material striking surface.

RELATED APPLICATION DATA

[0002] This claims the benefit of U.S. Provisional Patent Application No. 62/881,463, filed on August 1, 2019, and U.S. Provisional Patent Application No. 63/046,505, filed on June 30, 2020, the contents of all of which are entirely incorporated herein by reference.

BACKGROUND

[0003] As golf clubs are the sole instruments that set golf balls in motion during play, the golf industry has seen improvements in putters and golf club head designs in recent years. However, it is known, that when it comes to designing putter-type club heads, golfers tend to prioritize personal preference characteristics (*i.e.* club head feel, club head aesthetics, club head sound etc.) over performance.

[0004] To putt a golf ball in the hole, a golfer must successfully impact the golf ball (with a golf club head and more particularly a putter-type golf club head) at a proper speed and face angle. This provides a challenge to all golfers, as many struggle to consistently impact the golf ball at the same location putt after putt. Striking the golf ball at various locations on the putter-type club head can alter the amount of energy transferred from the putter head to the golf ball during initial contact, impact feel, impact sound and/or travel direction of the golf ball. There is a need in the art to create a putter-type golf club head that balances golfers' personal preference characteristics while considering various impact locations.

BRIEF DESCRIPTION OF THE DRAWINGS

[0005] FIG. 1 shows a heel side perspective view of a striking surface having continuous grooves for a non-insert style club head according to one embodiment.

[0006] FIG. 2 shows a face on view of the striking surface of FIG. 1.

[0007] FIG. 3 shows a close-up face on view of the striking surface of FIG. 2.

[0008] FIG. 4 shows a seven variable gradient map that compares ball speed, impact location, and the land area percentage for putts of 10 feet in length.

[0009] FIG. 5 shows a seven variable gradient map that compares ball speed, impact location, and the land area percentage for putts of 25 ft in length.

[0010] FIG. 6 shows an exploded view of a striking surface having continuous grooves for an insert style club head according to one embodiment.

[0011] FIG. 7 shows a partially assembled view of a striking surface having continuous grooves of FIG. 6.

[0012] FIG. 8 shows a face on view of the striking surface of FIG. 6.

[0013] FIG. 9 shows a face on view of the striking surface of FIG. 7.

[0014] FIG. 10 shows a partially assembled view of a striking surface having discrete pill shaped voids for an insert style club head according to one embodiment.

[0015] FIG. 11 shows a face on view of the striking surface of FIG. 10.

[0016] FIG. 12 shows another face on view of a striking surface having discrete pill shaped voids for an insert style club head according to one embodiment.

[0017] FIG. 13 shows an exploded view of the striking surface of FIG. 12.

[0018] FIG. 14 shows a partially assembled view of a striking surface having discrete hexagonal shaped voids for an insert style club head according to one embodiment.

[0019] FIG. 15 shows an exploded view of the insert having discrete hexagonal voids of FIG. 14.

[0020] FIG. 16 shows an assembled face on view of FIG. 14.

[0021] FIG. 17 shows a heel side perspective view of a striking surface having continuous grooves for an insert style club head according to one embodiment.

[0022] FIG. 18 shows an exploded view of the insert of FIG. 17.

[0023] FIG. 19 shows an assembled face on view of FIG. 17.

[0024] FIG. 20 shows an exploded view of an insert having discrete concentric radiating voids.

[0025] FIG. 21 shows an assembled face on view of the insert of FIG. 20.

[0026] FIG. 22 shows a non-assembled face on view of the second material of FIG. 20.

[0027] FIG. 23 shows a cross sectional view of FIG. 22.

[0028] FIG. 24 shows a bar graph that compares the ball speed and ball impact location for various exemplary putter embodiments for putts of 10 feet in length.

[0029] FIG. 25 shows a bar graph that compares the ball speed and ball impact location for various exemplary putter embodiments for putts of 25 feet in length.

[0030] FIG. 26 shows a bar graph that compares the ball speed and ball impact location for various exemplary putter embodiments for putts of 25 feet in length.

DESCRIPTION

[0031] Directed herein are golf club heads, and in particular, a putter-type golf club heads comprising a striking surface capable of achieving consistent ball speeds across the striking surface to account for various ball impact locations. This striking surface has at

least two materials that differs in concentration away from the geometric center (or center region) of the striking surface to provide this consistency. Consistent (or uniform) ball speed is achieved throughout the striking surface as the portion of the golf ball that contacts the striking surface interacts with at least two materials having a differing material property (or characteristic).

[0032] The differing material property can be (but not an exhaustive list of) tensile strength, flexural modulus, or material hardness. A uniform ball speed is accomplished by the combination of a dual material striking surface and varying the amount of the first material and/or the second material away from the geometric center (or center region) of the striking surface. In many embodiments, the first and second material cooperate to form a softer, more flexible center region and opposing the center region either in a heel or toe direction, the first and second material cooperate to form a harder, stiffer, and less flexible region. This is because contact outside the geometric center of the striking surface (or club head sweet spot) results in less energy transfer from the club head to the golf ball.

[0033] Creating a center region that is less responsive than the corresponding heel and toe regions can be accomplished in many ways. For example, in embodiments, where a first soft material dominates a less soft second material, a less responsive center region can be formed. In other embodiments, a less responsive center region can be formed by controlling the void and/or recess patterns to form larger first material land areas at the center region than at adjacent heel and toe regions.

[0034] The term or phrase “lie angle” used herein can be defined as being the angle between a golf shaft (not shown) and a playing surface once the sole contacts the playing surface. The lie angle of a golf club head can also be referred to as the angle formed by the intersection of the centerline of the golf shaft and the playing surface when the sole of the golf club head is resting on the playing surface.

[0035] The term or phrase “integral” used herein can be defined as two or more elements if they are comprised of the same piece of material. As defined herein, two or

more elements are “non-integral” if each element is comprised of a different piece of material.

[0036] The term or phrase “couple”, “coupled”, “couples”, and “coupling” used herein can be defined as connecting two or more elements, mechanically or otherwise. Coupling (whether mechanical or otherwise) can be for any length of time, e.g. permanent or semi-permanent or only for an instant. Mechanical coupling and the like should be broadly understood and include mechanical coupling of all types. The absence of the word “removably,” “removable,” and the like near the word “coupled,” and the like does not mean that the coupling, in question is or is not removable.

[0037] The term or phrase “head weight” or “head mass” used herein can be defined as the total mass or weight of the putter.

[0038] The term or phrase “attach”, “attached”, “attaches, and “attaching” used herein can be defined as connecting or being joined to something. Attaching can be permanent or semi-permanent. Mechanically attaching and the like should be broadly understood and include all types of mechanical attachment means. Integral attachment means should be broadly understood and include all types of integral attachment means that permanently connects two or more objects together.

[0039] The term or phrase “loft angle” used herein can be defined as the angle between the striking surface and the golf shaft. In other embodiments, the loft angle can be defined herein as such: the striking surface comprises a striking surface center point and a loft plane. The striking surface center point is equidistant from (1) the lower edge and upper edge of the strike face, as well as, (2) equidistant from the heel end and toe end of strike face. The loft plane is tangent to the strike surface of the putter type golf club head. The golf shaft comprises a centerline axis that extends the entire length of the golf shaft. The loft angle is between the centerline axis of the golf shaft and the loft plane of the putter. The loft angle of the putter-type golf club head can also be defined herein as the angle between the striking surface and the golf shaft (not shown) when a centerline of the golf shaft is generally vertical (i.e. forms a generally 90° angle with the playing surface).

[0040] The terms "first," "second," "third," "fourth," and the like in the description and in the claims, if any, are used for distinguishing between similar elements and not necessarily for describing a particular sequential or chronological order. It is to be understood that the terms so used are interchangeable under appropriate circumstances such that the embodiments described herein are, for example, capable of operation in sequences other than those illustrated or otherwise described herein. Furthermore, the terms "include," and "have," and any variations thereof, are intended to cover a non-exclusive inclusion, such that a process, method, system, article, device, or apparatus that comprises a list of elements is not necessarily limited to those elements but may include other elements not expressly listed or inherent to such process, method, system, article, device, or apparatus.

[0041] The terms "left," "right," "front," "back," "top," "bottom," "over," "under," and the like in the description and in the claims, if any, are used for descriptive purposes and not necessarily for describing permanent relative positions. It is to be understood that the terms so used are interchangeable under appropriate circumstances such that the embodiments of the apparatus, methods, and/or articles of manufacture described herein are, for example, capable of operation in other orientations than those illustrated or otherwise described herein.

[0042] The term "center region" can be defined as the region on the striking surface that includes the geometric center. The center region can extend from the upper border of the striking surface to the lower border of the striking surface and have a heel-to-toe span of approximately 0.1 inch, 0.2 inch, 0.3 inch, 0.4 inch, 0.5 inch, 0.6 inch, 0.7 inch, 0.8 inch, 0.9 inch, 1.0 inch, 1.1 inch, 1.2 inch, 1.3 inch, 1.4 inch, 1.5 inch, 1.6 inch, 1.7 inch, 1.8 inch, 1.9 inch, or 2.0 inch.

[0043] The term "heel region" can be defined as the region on the striking surface that extends from the heel end of the striking surface (and/or club head) up to the center region heel side border. The term "toe region" can be defined as the region on the striking surface that extends from the toe end of the striking surface (and/or club head) up to the center region toe side border.

[0044] “A,” “an,” “the,” “at least one,” and “one or more” are used interchangeably to indicate that at least one of the item is present; a plurality of such items may be present unless the context clearly indicates otherwise. All numerical values of parameters (e.g., of quantities or conditions) in this specification, including the appended claims, are to be understood as being modified in all instances by the term “about” whether or not “about” actually appears before the numerical value. “About” indicates that the stated numerical value allows some slight imprecision (with some approach to exactness in the value; about or reasonably close to the value; nearly). If the imprecision provided by “about” is not otherwise understood in the art with this ordinary meaning, then “about” as used herein indicates at least variations that may arise from ordinary methods of measuring and using such parameters. In addition, disclosure of ranges includes disclosure of all values and further divided ranges within the entire range. Each value within a range and the endpoints of a range are hereby all disclosed as separate embodiment. The terms "comprises," "comprising," "including," and "having," are inclusive and therefore specify the presence of stated items, but do not preclude the presence of other items. As used in this specification, the term "or" includes any and all combinations of one or more of the listed items. When the terms first, second, third, etc. are used to differentiate various items from each other, these designations are merely for convenience and do not limit the items.

[0045] In many examples as used herein, the term “approximately” can be used when comparing one or more values, ranges of values, relationships (e.g., position, orientation, etc.) or parameters (e.g., velocity, acceleration, mass, temperature, spin rate, spin direction, etc.) to one or more other values, ranges of values, or parameters, respectively, and/or when describing a condition (e.g., with respect to time), such as, for example, a condition of remaining constant with respect to time. In these examples, use of the word “approximately” can mean that the value(s), range(s) of values, relationship(s), parameter(s), or condition(s) are within $\pm 0.5\%$, $\pm 1.0\%$, $\pm 2.0\%$, $\pm 3.0\%$, $\pm 5.0\%$, and/or $\pm 10.0\%$ of the related value(s), range(s) of values, relationship(s), parameter(s), or condition(s), as applicable.

[0046] Before any embodiments of the disclosure are explained in detail, it is to be understood that the disclosure is not limited in its application to the details of construction and the arrangement of components set forth in the following description or illustrated in the following drawings. The disclosure is capable of other embodiments and of being practiced or of being carried out in various ways.

[0047] Presented herein are putter-type golf club heads comprising a plurality of striking surfaces capable of achieving consistent ball speeds across the striking surface to account for various ball impact locations. In many embodiments, the putter-type golf club head described herein includes a putter body comprising a dual-material striking surface having a first material and a second material. The first and second material varies in concentration away from the geometric center of the striking surface in a heel-to-toe direction to provide consistent ball speeds.

[0048] For example, in many embodiments, the proportion (or relationship) between the first material and the second material differs to account for where the ball could impact the striking surface (i.e. towards the toe portion, towards the heel portion, or towards the center portion). Altering the striking surface material relationship directly correlates to the impact efficiency or ball speed produced between the golf club head and the golf ball upon impact.

I. Putter-Type Golf Club Heads

[0049] In many of the embodiments described herein, the golf club head is a putter-type golf club head. FIGS. 1-23 illustrates exemplary embodiments of putter-type golf club heads having a multi-material striking surface capable of controlling ball speeds across the striking surface, while accounting for impact feel and impact sound upon ball impact.

2. Loft Angle

[0050] In many embodiments, the putter-type golf club head can have a loft angle less than 10 degrees. In many embodiments, the loft angle of the club head can be between 0 and 5 degrees, between 0 and 6 degrees, between 0 and 7 degrees, or between

0 and 8 degrees. For example, the loft angle of the club head can be less than 10 degrees, less than 9 degrees, less than 8 degrees, less than 7 degrees, less than 6 degrees, less than 5 degrees, less than 4 degrees, less than 3 degrees, or less than 2 degrees. For further example, the loft angle of the club head can be 0 degrees, 1 degree, 2 degrees, 3 degrees, 4 degrees, 5 degrees, 6 degrees, 7 degrees, 8 degrees, 9 degrees, or 10 degrees.

3. *Weight*

[0051] In many embodiments, the putter-type golf club head can have a weight that ranges between 320 and 385 grams. In other embodiments, the putter-type golf club head can range between 320 grams – 325 grams, 325 grams – 330 grams, 330 grams – 335 grams, 335 grams – 340 grams, 340 grams – 345 grams, 345 grams – 350 grams, 350 grams – 355 grams, 355 grams – 360 grams, 360 grams – 365 grams, 365 grams – 370 grams, 370 grams – 375 grams, 375 grams – 380 grams, or 380 grams – 385 grams. In some embodiments, the weight of the putter-type golf club head can be 320 grams, 321 grams, 322 grams, 323 grams, 324 grams, 325 grams, 326 grams, 327 grams, 328 grams, 329 grams, 330 grams, 331 grams, 332 grams, 333 grams, 334 grams, 335 grams, 336 grams, 337 grams, 338 grams, 339 grams, 340 grams, 341 grams, 342 grams, 343 grams, 344 grams, 345 grams, 346 grams, 347 grams, 348 grams, 349 grams, 350 grams, 351 grams, 352 grams, 353 grams, 354 grams, 355 grams, 356 grams, 357 grams, 358 grams, 359 grams, 360 grams, 361 grams, 362 grams, 363 grams, 364 grams, 365 grams, 366 grams, 367 grams, 368 grams, 369 grams, 370 grams, 371 grams, 372 grams, 373 grams, 374 grams, 375 grams, 376 grams, 377 grams, 378 grams, 379 grams, 380 grams, 381 grams, 382 grams, 383 grams, 384 grams, or 385 grams.

4. *Materials*

[0052] The material of the putter-type golf club head can be constructed from any material used to construct a conventional club head. For example, the material of the putter-type golf club head can be constructed from any one or combination of the following: 8620 alloy steel, S25C steel, carbon steel, maraging steel, 17-4 stainless steel, 1380 stainless steel, 303 stainless steel, stainless steel alloys, or any metal or combination of metals for creating a golf club head. In other embodiments, the putter-type golf club heads can be constructed from non-metal materials such as a thermoplastic polyurethane material, a thermoplastic elastomer, and/or a thermoplastic composite material.

1. Composition and Setup of Putter-Type Golf Club Head

[0053] In many embodiments, the putter-type golf club head comprises a club head body (may also be referred to as “body” or “putter body”). The club head body comprises a toe portion, a heel portion, a top rail portion, a sole portion, a striking surface (or a portion of a striking surface), and a rear portion. The striking surface can provide a surface adapted for impact with a golf ball. The rear portion is rearwardly spaced from the striking surface. The sole portion is defined as being between the striking surface and the rear portion and resting on a ground plane (or playing surface) at an address position. The top rail can be formed opposite the sole portion. The striking surface is defined by the sole portion, the top rail portion, a heel portion and a toe portion, which is opposite the heel portion.

[0054] As mentioned above, in many embodiments, the putter-type golf club head can be configured to reside in the “address position”. Unless otherwise described or stated, the putter-type golf club head is in an address position for all reference measurements, ratios, and/or descriptive parameters. The address position can be referred to as being in a state where (1) the sole portion of the putter-type golf club head rests on the ground plane which contacts and is parallel to a playing surface and/or ground plane and (2) the striking surface is substantially perpendicular to the ground plane and/or playing surface.

2. Striking Surface

[0055] In many embodiments, the striking surface can be defined by at least the toe portion, the heel portion, the top rail portion, and the sole portion of the putter body. Further, as previously described, the striking surface can comprise of a multi-material striking surface. For example, the striking surface can include at least a first material and a second material that cooperate such that when a golf ball impacts the striking surface, the golf ball engages with two or more materials (i.e. a first material, a second material, etc.) having unique material characteristics to normalize ball speed across the club head while improving personal preference characteristics for a wide range of individuals (i.e. impact sound and/or impact feel).

[0056] In many embodiments, the first material can be softer, more flexible, and more deformable than the second material. In other embodiments, the second material

can be harder, less flexible, and less deformable than the first material. In many embodiments, the second material can surround, border, or envelope the first material.

3. *Material Characteristic of the First Material*

[0057] The first material of the striking surface can vary based upon the selection of the second material, as the second material comprises the majority of the striking surface. In many embodiments, the first material can be defined by a predetermined material characteristic (but not limited to) the hardness, the tensile strength, the flexure modulus, or the specific gravity of the material.

[0058] The hardness of the first material is generally softer than the hardness of the second material. In many embodiments, the hardness of the first material can have a Shore A value that varies between 30A and 95A. In some embodiments, the hardness of the first material can have a Shore A hardness value between 30A – 40A, 40A – 50A, 50A – 60A, 70A – 80A, 80A – 90A, or 90A – 95A. In alternative embodiments, the hardness of the first material can have a Shore A hardness value between 30A – 35A, 35A – 40A, 40A – 45A, 45A – 50A, 50A – 55A, 55A – 60A, 60A – 65A, 65A – 70A, 70A – 75A, 75A – 80A, 80A – 85A, 85A – 90A, or 90A – 95A. In additional embodiments, the hardness of the first material can have a Shore A less than 95A, less than 90A, less than 85A, less than 80A, less than 75A, less than 70A, less than 65A, less than 60A, less than 55A, less than 50A, less than 45A, less than 40A, or less than 35A. In other embodiments, the hardness of the first material can have a Shore A hardness of 30A, 31A, 32A, 33A, 34A, 35A, 36A, 37A, 38A, 39A, 40A, 41A, 42A, 43A, 44A, 45A, 46A, 47A, 48A, 49A, 50A, 51A, 52A, 53A, 54A, 55A, 56A, 57A, 58A, 59A, 60A, 61A, 62A, 63A, 64A, 65A, 66A, 67A, 68A, 69A, 70A, 71A, 72A, 73A, 74A, 75A, 76A, 77A, 78A, 79A, 80A, 81A, 82A, 83A, 84A, 85A, 86A, 87A, 88A, 89A, 90A, 91A, 92A, 93A, 94A, or 95A.

[0059] The tensile strength of the first material is generally less than the tensile strength of the second material. The tensile strength of the first material can be between 0.5 MPa and 50 MPa. In many embodiments, the tensile strength of the first material can be between 0.5 MPa to 5.5 MPa, 5.5 MPa to 10.5 MPa, 10.5 MPa to 15.5 MPa, 15.5 MPa to 20.5 MPa, 20.5 MPa to 25.5 MPa, 25.5 MPa to 30.5 MPa, 30.5 MPa to 35.5 MPa, 35.5

MPa to 40 MPa, 40 MPa to 45.5 MPa, or 45.5 MPa to 50 MPa. In alternative embodiments, the tensile strength of the first material can be less than 50 MPa, less than 45 MPa, less than 40 MPa, less than 35 MPa, less than 30 MPa, less than 25 MPa, less than 20 MPa, less than 15 MPa, less than 10 MPa, or less than 5 MPa. In specific embodiments, the tensile strength of the first material can be approximately 0.5 MPa, approximately 5 MPa, approximately 10 MPa, approximately 15 MPa, approximately 20 MPa, approximately 25 MPa, approximately 30 MPa, approximately 35 MPa, approximately 40 MPa, approximately 45 MPa, or approximately 50 MPa.

[0060] The flexure modulus of the first material is generally lower than the flexure modulus of the second material. The flexure modulus of the first material can be between 0.5 MPa and 90 MPa. In many embodiments, the flexure modulus of the first material can be between 0.5 MPa and 5.5 MPa, 5.5 MPa and 10.5 MPa, 10.5 MPa to 15.5 MPa, 15.5 MPa to 20.5 MPa, 20.5 MPa to 25.5 MPa, 25.5 MPa to 30.5 MPa, 30.5 MPa to 35.5 MPa, 35.5 MPa to 40 MPa, 40 MPa to 45.5 MPa, 45.5 MPa to 50 MPa, 50 MPa to 55 MPa, 55 MPa to 60 MPa, 60 MPa to 65 MPa, 65 MPa to 70 MPa, 70 MPa to 75 MPa, 75 MPa to 80 MPa, 80 MPa to 85 MPa, or 85 MPa to 90 MPa. In alternative embodiments, the flexure modulus of the first material can be less than 90 MPa, less than 85 MPa, less than 80 MPa, less than 75 MPa, less than 70 MPa, less than 65 MPa, less than 60 MPa, less than 55 MPa, less than 50 MPa, less than 45 MPa, less than 40 MPa, less than 35 MPa, less than 30 MPa, less than 25 MPa, less than 20 MPa, less than 15 MPa, less than 10 MPa, or less than 5 MPa. In specific embodiments, the flexure modulus of the first material can be approximately 0.5 MPa, approximately 5 MPa, approximately 10 MPa, approximately 15 MPa, approximately 20 MPa, approximately 25 MPa, approximately 30 MPa, approximately 35 MPa, approximately 40 MPa, approximately 45 MPa, approximately 50 MPa, approximately 55 MPa, approximately 60 MPa, approximately 65 MPa, approximately 70 MPa, approximately 75 MPa, approximately 80 MPa, approximately 85 MPa, or approximately 90 MPa.

[0061] The specific gravity of the first material is generally lower (or can be the same) as the specific gravity of the second material. The specific gravity of the first material can be between 0.5 and 2. In many embodiments, the specific gravity of the first

material can be between 0.5 – 0.75 , 0.75– 1, 1 – 1.25 , 1.25– 1.5, 1.5 – 1.75, or 1.75 – 2.0. In alternative embodiments, the specific gravity of the first material can be less than 2, less than 1.5, or less than 1.0.

[0062] The first material is generally comprised from a substantially non-metallic material and more preferably a polymeric material. For example, in many embodiments, the first material can be formed from an elastomer, a polyurethane, a thermoplastic elastomer, a thermoset elastomer, a thermoplastic polyurethane, a thermoset polyurethane, a viscoelastic material, a urethane, other polymers, other polymeric materials with doped metal portions, or combinations thereof. In many embodiments, the first material is selected from one of the categories listed above to satisfy one or more of the material characteristics listed above.

4. Material Characterization of the Second Material

[0063] The second material of the striking surface can vary based upon the selection of the first material, as the first material provides certain ball impact characteristics. In many embodiments, the second material can be defined by a predetermined material characteristic (but not limited to) the hardness, tensile strength, flexure modulus, and specific gravity of the material.

[0064] The hardness of the second material is generally harder than the hardness of the first material. In many embodiments, the hardness of the second material can have a Shore D value that varies between 60D and 100D. In some embodiments, the hardness of the second material can have a Shore D hardness value between 60D – 70D, 70D – 80D, 80D – 90D, or 90D – 100D. In alternative embodiments, the hardness of the second material can have a Shore D hardness between 60D – 65D, 65D – 70D, 70D – 75D, 75D – 80D, 80D – 85D, 85D – 90D, 90D – 95D, or 95D – 100D. In additional embodiments, the hardness of the second material can have a Shore D hardness greater than 60D, greater than 65D, greater than 70D, greater than 75D, greater than 80D, greater than 85D, greater than 90D, greater than 95D, or greater than 100D. In other embodiments, the hardness of the second material can have a Shore D hardness of 60D, 61D, 62D, 63D, 64D, 65D, 66D, 67D, 68D, 69D, 70D, 71D, 72D, 73D, 74D, 75D, 76D, 77D, 78D, 79D,

80D, 81D, 82D, 83D, 84D, 85D, 86D, 87D, 88D, 89D, 90D, 91D, 92D, 93D, 94D, 95D, 96D, 97D, 98D, 99D, or 100D.

[0065] The tensile strength of the second material is generally greater than the tensile strength of the first material. The tensile strength of the second material can be between 40 MPa and 1040 MPa. In many embodiments, the tensile strength of the second material can be between 40 MPa to 140 MPa, 140 MPa to 240 MPa, 240 MPa to 340 MPa, 340 MPa to 440 MPa, 440 MPa to 540 MPa, 540 MPa to 640 MPa, 640 MPa to 740 MPa, 840 MPa to 940 MPa, or 940 MPa to 1040 MPa. In alternative embodiments, the tensile strength of the second material can be greater than 40 MPa, greater than 140 MPa, greater than 240 MPa, greater than 340 MPa, greater than 440 MPa, greater than 540 MPa, greater than 640 MPa, greater than 740 MPa, greater than 840 MPa, greater than 940 MPa, or greater than 1040 MPa. In specific embodiments, the tensile strength of the second material can be approximately 41 MPa, 42 MPa, 43 MPa, 44 MPa, 45 MPa, 46 MPa, 47 MPa, 48 MPa, 49 MPa, 50 MPa, 51 MPa, 52 MPa, 53 MPa, 54 MPa, 55 MPa, 56 MPa, 57 MPa, 58 MPa, 59 MPa, 60 MPa, 61 MPa, 62 MPa, 63 MPa, 64 MPa, 65 MPa, 66 MPa, 67 MPa, 68 MPa, 69 MPa, or 70 MPa. In alternative embodiments, the tensile strength of the second material can be 141 MPa, 241 MPa, 341 MPa, 441 MPa, 541 MPa, 641 MPa, 741 MPa, 841 MPa, or 941 MPa.

[0066] The flexure modulus of the second material material is generally higher than the flexure modulus of the first material. The flexure modulus of the second material can be between 0.5 MPa and 300 MPa. In many embodiments, the flexure modulus of the second material can be between 0.5 MPa and 5.5 MPa, 5.5 MPa and 10.5 MPa, 10.5 MPa to 15.5 MPa, 15.5 MPa to 20.5 MPa, 20.5 MPa to 25.5 MPa, 25.5 MPa to 30.5 MPa, 30.5 MPa to 35.5 MPa, 35.5 MPa to 40 MPa, 40 MPa to 45.5 MPa, 45.5 MPa to 50 MPa, 50 MPa to 55 MPa, 55 MPa to 60 MPa, 60 MPa to 70 MPa, 70 MPa to 75 MPa, 75 MPa to 80 MPa, 80 MPa to 85 MPa, 85 MPa to 90 MPa, 90 MPa to 100 MPa, 100 MPa to 110 MPa, 110 MPa to 120 MPa, 120 MPa to 130 MPa, 130 MPa to 140 MPa, 140 MPa to 150 MPa, 150 MPa to 160 MPa, 160 MPa to 170 MPa, 170 MPa to 180 MPa, 180 MPa to 190 MPa, 190 MPa to 200 MPa, 200 MPa to 210 MPa, 210 MPa to 220 MPa, 220 MPa to 230 MPa, 240 MPa to 250 MPa, 250 MPa to 260 MPa, 260 MPa to 270 MPa, 270 MPa to 280

MPa, 280 MPa to 290 MPa, or 290 MPa to 300 MPa. In alternative embodiments, the flexure modulus of the second material can be less than 300 MPa, less than 275 MPa, less than 250 MPa, less than 225 MPa, less than 200 MPa, less than 175 MPa, less than 150 MPa, less than 125 MPa, less than 100 MPa, less than 75 MPa, less than 50 MPa, or less than 25 MPa. In specific embodiments, the flexural modulus of the second material be approximately 0.6 MPa, 5.6 MPa, 10.6 MPa, 15.6 MPa, 20.6 MPa, 25.6 MPa, 30.6 MPa, 35.6 MPa, 40.1 MPa, 45.6 MPa, 50.1 MPa, 55.1 MPa, 60.1 MPa, 70.1 MPa, 75.1 MPa, 80.1 MPa, 85.1 MPa, 90.1 MPa, 100.1 MPa, 110.1 MPa, 120.1 MPa, 130.1 MPa, 140.1 MPa, 150.1 MPa, 160.1 MPa, 170.1 MPa, 180.1 MPa, 190.1 MPa, 200.1 MPa, 210.1 MPa, 220.1 MPa, 230.1 MPa, 240.1 MPa, 250.1 MPa, 260.1 MPa, 270.1 MPa, 280.1 MPa, or 290.1 MPa.

[0067] The specific gravity of the second material is generally greater (or the same as) than the specific gravity of the first material. The specific gravity of the second material can be between 0.5 and 13.5. In many embodiments, the specific gravity of the second material can be between 0.5 – 1.5 , 1.5 – 2.5, 2.5 – 3.5 , 3.5 – 4.5 , 4.5 – 5.5, 5.5 – 6.5, 6.5 – 7.5, 7.5 – 8.5, 8.5 – 9.5, 9.5 – 10.5, 10.5 – 11.5, 11.5 – 12.5, or 12.5 – 13.5. In alternative embodiments, the specific gravity of the second material can be approximately 0.5, approximately 1.0, approximately 1.5, approximately 2.5, approximately 3.5, approximately 4.5, approximately 5.5, approximately 6.5, approximately 7.5, approximately 8.5, approximately 9.5, approximately 10.5, approximately 11.5, approximately 12.5, or approximately 13.5

[0068] The second material can be generally comprised from a substantially non-metallic material or metallic material. For example, in many embodiments, the second material can be formed from a non-metallic material (i.e. an elastomer, a polyurethane, a thermoplastic elastomer, a thermoset elastomer, a thermoplastic polyurethane, a thermoset polyurethane, a viscoelastic material, a urethane, other polymers, other polymeric materials with doped metal portions, or combinations thereof). In alternative embodiments, the second material can be constructed from a metal material. For example, the second material can be constructed from any one or combination of the following: 8620 alloy steel, S25C steel, carbon steel, maraging steel, 17-4 stainless steel,

1380 stainless steel, 303 stainless steel, stainless steel alloys, tungsten, aluminum, aluminum alloys, ADC-12, titanium, or titanium alloys. In many embodiments, the second material is selected from one of the categories listed above to satisfy one or more of the material characteristics listed above.

5. *First and Second Material Arrangement*

[0069] In many embodiments, the second material can define a plurality of recesses or voids that resemble any shape. The characteristics (i.e. geometry, shape, dimensions, and spacing distance) of the recesses or voids formed by the second material can vary to achieved desired performance, aesthetics, and feel attributes. For example, in many embodiments, the second material can define a plurality of discrete voids or recesses that generally define a pill shape, a hexagonal shape, a split hexagonal shape, a circular shape, a rectangular shape, a triangular shape, a pentagonal shape, an octagonal shape, a curvilinear shape, a diamond shape, and/or a trapezoidal shape. In alternative embodiments, the second material, can form continuous voids or recesses that can generally be defined by one or more continuous curvilinear groove(s), one or more continuous arcuate groove(s), one or more continuous arc like grooves, one or more continuous linear groove(s), or one or more combinations thereof.

[0070] The first material can be configured to fill, partially fill, reside, occupy and/or be complimentary with one or more of the plurality of discrete recesses or voids defined by the second material. For example, in many embodiments, the first material can partially or entirely fill one or more of the plurality of voids or recess described above. In alternative embodiments, the first material can fill, partially fill, reside, and/or be complimentary with one or more of the continuous voids or recesses mentioned above. In embodiments, where the first material partially fills the plurality of recesses or voids, air can occupy the remaining unfilled portion.

[0071] The first and second materials can be configured to cooperate with each other to create different material characteristic regions. In many embodiments, the center region of the striking surface can be softer than adjacent heel and toe regions. In alternative embodiments, the center region of the striking surface can be more flexible

than adjacent heel and toe regions. In other embodiments, the center region of the striking surface can be more deformable than adjacent heel and toe regions. Creating a center region that is more flexible, deformable, softer, and/or less responsive than adjacent heel and/or toe regions creates more uniform ball speed and sensory feedback characteristics (*i.e.* impact sound, impact feel, impact feedback, etc) across the striking surface.

[0072] Creating a center region that is less responsive than the corresponding heel and toe regions can be accomplished in many ways. For example, in embodiments, where a first soft material dominates a less soft second material, a less responsive center region is formed. In other embodiments, a less responsive center region can be formed by controlling the void and/or recess patterns to form larger first material land areas at the center region than at adjacent heel and toe regions.

I. Embodiments

Continuous Grooves (Non-Insert Style Putter)

[0073] FIGS. 1-5 illustrate an exemplary embodiment. More particularly, FIGS. 1-3 illustrate an example of a putter-type golf club head **100** comprising a dual-material striking surface **107** having a first material **109** and a second material **110**. The putter-type golf club head comprises a putter body **101** having a toe portion **102**, a heel portion **103** opposite the toe portion **102**, a top rail portion **104**, a sole portion **105** opposite the top rail portion **104**, a portion of a striking surface **107**, and a rear portion **106** opposite the striking surface portion **107**.

[0074] Further, FIGS. 1 - 3 illustrate the striking surface **107** of the putter body **100** forming a plurality of continuous groove recesses **112**. These continuous groove recesses **112** can separate the striking surface **107** into second material land areas that form ball contact surfaces and continuous groove areas that form non-ball contact surfaces (upon golf ball impact). Through a combination of continuous recesses being entirely arcuate or having arcuate portions, the proportion of ball contact surfaces and non-ball contact surfaces can vary across the striking surface **107**, yet create a consistent ball speed upon impact across the striking surface.

[0075] For example, FIG. 2 illustrates a possible arrangement where the arcuate portions of each the continuous groove recesses **112** are arranged to form a denser, more packed center region. This causes the center region to be less responsive to ball impacts than at areas (or regions) away from the center region (*i.e.* towards the heel or toe) as more continuous groove areas (non-ball contact surfaces) are present than ball contact surfaces. Additionally, to create a more densely packed center region towards the top rail and sole (at the center of the strike face), are entirely arcuate recesses (also referred to as semi-circle recesses) to increase the amount of continuous recesses (nonball contact surfaces). These semi-circle recesses are not present moving away from the center region and at the heel end and toe end. The arrangement can be progressive, or asymmetrically arranged from the center to the heel end and/or the center to toe end of the striking surface.

[0076] Moving away from the center region toward the heel or toe, the spacing distance between adjacent arcuate portions can gradually increase to introduce more ball contact surface. Increasing the amount of ball contact surfaces (in a heel-to-toe direction) creates a more responsive region when compared to the less responsive center region. As the response of the striking surface changes, this aids in creating a consistent ball speed across the striking surface.

[0077] Further, as previously mentioned, the golf club head **100** can be configured to reside in an “address position”. The address position is the reference orientation of the golf club head for all reference measurements, ratios, and descriptive parameters described below. Specifically, FIG. 1 illustrates the putter-type golf club head **100** comprising a plurality of continuous groove recesses **112** defined by the putter body **101**. In other words, the putter-type golf club head **100** is a non-insert style club head.

[0078] The plurality of continuous groove recesses **112** can resemble many shapes or geometries. For example, in this exemplary embodiment, the plurality of continuous groove recesses **112** can be defined by one or more continuous curvilinear groove recesses, one or more continuous arcuate groove recesses (may also be referred to as “continuous arc-like groove recesses”), one or more continuous linear groove recesses,

and/or combinations thereof. In this specific embodiment, the putter-body **101** defines eight continuous arcuate groove recesses **113** (or arc-like grooves), one continuous linear groove recess **114**, and eight continuous groove recesses **115** that define at least one linear portion and an arcuate portion.

[0079] In alternative embodiments of putter-type golf club heads having continuous groove recesses **112**, the putter body can define one or more continuous arcuate groove recesses **113**, two or more continuous arcuate groove recesses **113**, three or more continuous arcuate groove recesses **113**, four or more continuous arcuate groove recesses **113**, five or more continuous arcuate groove recesses **113**, six or more continuous arcuate groove recesses **113**, seven or more continuous arcuate groove recesses **113**, eight or more continuous arcuate groove recesses **113**, nine or more continuous arcuate groove recesses **113**, ten or more continuous arcuate groove recesses **113**, or eleven or more continuous arcuate groove recesses **113**.

[0080] In the same or alternative embodiments, the putter-type golf club head can define one or more continuous groove recesses that defines at least one linear portion and an arcuate portion **115**, two or more continuous groove recesses that defines at least one linear portion and an arcuate portion **115**, three or more continuous groove recesses that defines at least one linear portion and an arcuate portion **115**, four or more continuous groove recesses that defines at least one linear portion and an arcuate portion **115**, five or more continuous groove recesses that defines at least one linear portion and an arcuate portion **115**, six or more continuous groove recesses that defines at least one linear portion and an arcuate portion **115**, seven or more continuous groove recesses that defines at least one linear portion and an arcuate portion **115**, eight or more continuous groove recesses that defines at least one linear portion and an arcuate portion **115**, nine or more continuous groove recesses that defines at least one linear portion and an arcuate portion **115**, ten or more continuous groove recesses that defines at least one linear portion and an arcuate portion **115**, or eleven or more continuous groove recesses that defines at least one linear portion and an arcuate portion **115**. In many embodiments, the arcuate portions of the continuous linear groove recesses are positioned between a first

linear portion (proximal to the heel portion) and a second linear portion (proximal to the toe portion).

[0081] With continued reference to FIG. 2, each continuous groove recess of the plurality of continuous groove recesses **112** (although not required) comprises either (1) a first end **116** and a second end **117** that can be connected to an upper border **118** of the striking surface **107**, (2) a first end **116** and a second end **117** that is connected to either the heel **103** or toe portion **102** of the striking surface, or (3) a first end **116** and a second end **117** that can be connected to the lower border **119** of the striking surface **107**. This type of groove configuration permits the land area (or second material area) between the groove recesses to be finely adjusted without requiring the continuous recesses to vary in width. This aids in achieving a consistent ball speed across the striking surface **107**.

[0082] In many embodiments, the plurality of continuous groove recesses can be symmetrical about the centerline axis of the entirely continuous linear groove recess **114** that extends from the heel portion **103** to the toe portion **102**. Each of the plurality of continuous groove recesses between the entirely continuous linear groove recess **114** and the upper border **118** (proximal to the top rail **104** of the putter body **101**) of the striking surface **107** can comprise arcuate portions and/or continuous arcuate groove recesses **113** that are concave up relative to the upper border **118** of the striking surface **107**. Similarly, each of the plurality of continuous groove recesses between the entirely continuous linear groove recess **114** and the lower border **119** (proximal to the sole portion **105** of the putter body **101**) of the striking surface **107** can comprise arcuate portions and/or continuous arcuate groove recesses that are concave down relative to the lower border **119** of the striking surface **107**.

[0083] Each of the continuous groove recesses can have a constant width measured transversely in a top rail **104**-to-sole **105** direction. In many embodiments, the width of each continuous groove recess can range between 0.020 inch to 0.040 inch. For example, the width of each continuous groove recess **112** can be approximately 0.020 inches, approximately, 0.021 inches, approximately 0.022 inches, approximately 0.023 inches, approximately 0.024 inches, approximately 0.025 inches, approximately 0.026 inches,

approximately 0.027 inches, approximately 0.028 inches, approximately 0.029 inches, approximately 0.030 inches, approximately 0.031 inches, approximately 0.032 inches, approximately 0.033 inches, approximately 0.034 inches, approximately 0.035 inches, approximately 0.036 inches, approximately 0.037 inches, approximately 0.038 inches, approximately 0.039 inches, or approximately 0.040 inches.

[0084] In many embodiments, each arcuate portion and/or continuous arcuate groove recess **113** of the plurality of continuous groove recesses can have a maximum length (measured in a heel **103**-to-toe **102** direction) that is between 1% and 50% of the maximum length of the striking surface **107**. For example, each arcuate portion and/or continuous arcuate groove recess of the plurality of continuous groove recesses can have a maximum length that is greater than 1% of the striking surface **107**, greater than 5% of the striking surface **107**, greater than 10% of the striking surface **107**, greater than 15% of the striking surface **107**, greater than 20% of the striking surface **107**, greater than 25% of the striking surface **107**, greater than 30% of the striking surface **107**, greater than 35% of the striking surface **107**, greater than 40% of the striking surface **107**, or greater than 45% of striking surface **107**.

[0085] In the same or alternative embodiments, each arcuate portion or continuous arcuate groove recess **113** of the plurality of continuous groove recesses can have a maximum length that is less than 50% of the striking surface **107**, less than 45% of the striking surface **107**, less than 40% of the striking surface, less than 35% of the striking surface **107**, less than 30% of the striking surface **107**, less than 25% of the striking surface **107**, less than 20% of the striking surface **107**, less than 15% of the striking surface **107**, or less than 10% of the striking surface **107**.

[0086] In other embodiments, each arcuate portion or continuous arcuate groove recess **113** of the plurality of continuous groove recesses **112** can have a maximum length that is between approximately 1% and approximately 50% of the striking surface **107**, between approximately 1% and approximately 45%, between approximately 1% and approximately 40%, between approximately 1% and 35%, between approximately 1%

and approximately 30%, between approximately 1% and approximately 25%, or between approximately 1% and 20% of the maximum length of the striking surface **107**.

[0087] In many embodiments to control the relationship (or ratio) between the first material **109** and the second material **110**, the diameter and arc length of each arcuate groove portion and/or each continuous arcuate groove recess **113** increases in a direction from the upper border **118** to the entirely continuous linear groove recess **114**. This can reduce the spacing distance (or second material area) between groove recesses in a heel-to-toe direction and/or top rail-to-sole direction. Similarly, in the same embodiment or other embodiments, the diameter and arc length of each arcuate portion and/or continuous arcuate groove recess increases in a direction from the lower border **119** to the entirely continuous linear groove recess **114**. This can reduce the spacing distance (or second material area) between groove recesses in a heel-to-toe direction and/or top rail-to-sole direction. The configuration of each groove comprising arcuate portions and/or continuous arcuate grooves increasing in diameter and/or arc length from the upper border **118** to the entirely continuous linear groove **114** and from the lower border **119** to the entirely continuous linear groove **114** enables the groove recess to maintain a constant width while achieving a striking surface **107** that can control the ball speed across the striking surface **107** as the ratio of the first material **109** and second material varies **110**.

[0088] In many of the continuous groove recess embodiments, when the club head is in an address position, the striking surface **107** comprises a striking surface imaginary vertical axis **120** that extends through a geometric center **108** of the striking surface **107** in a top rail-to-sole direction (as shown by FIG. 2). Further, a total of five other vertical axes are shown in FIG. 3 (striking surface imaginary vertical reference axis **120**, heel and toe vertical axes **121** at 0.25 inch from the center, and heel and toe vertical axes **122** at 0.5 inch from the center. These vertical axes **121**, **122** are offset from the striking surface imaginary vertical axis in both a heel **103** and toe **102** direction at 0.25 inch and 0.50 inch.

[0089] As illustrated by FIG. 3, adjacent continuous grooves **112** are closer to one another (i.e. packed more closely, smaller land (or second material area) between groove

recesses) along the striking surface imaginary vertical axis **120** than at the vertical reference axis at 0.25 inch **121** and 0.5 inch **122** (heel-to-toe direction) due to the groove recess spacing distance and arcuate portions. Similarly, adjacent continuous groove recess are closer to one another (i.e. packed more closely, small land area between grooves) at the vertical reference axis at 0.25 inch **121** than at the vertical reference axis at 0.5 inch **122**.

Continuous Grooves (Insert Style Putter)

[0090] FIGS. 6-9 illustrate another exemplary embodiment. More particularly, FIGS. 6-9 illustrate an example of a putter-type golf club head **200** comprising a dual-material striking surface **207** having a first material **209** and a second material **210**. The golf club head **200** of FIGS. 6-9 and the golf club head **100** of FIGS. 1-3 are similar in many respects, except for that the golf club head **200** is an insert style putter.

[0091] FIGS. 6 - 9 illustrate a two-piece putter insert **224** comprising a first material **209** (also referred to as “first part”) and a second material **210** (also be referred to as “second part”). With specific reference to FIG. 6, the second part forms (or defines) a plurality of continuous groove voids **212** that separate the striking surface **207** into second material land areas. The first part of the putter insert **224** comprises a plurality of protruding geometries that are complimentary to a corresponding continuous groove void **212**. By coupling the first part of the insert with the second part of the insert, the plurality of protruding geometries can be flush with the second material land areas (*i.e.* on the same surface or plane). Thereby, the plurality of protruding geometries can form first material land areas. The first material land areas and the second material land areas engage with at least a portion of the golf ball upon golf ball impact.

[0092] This embodiment illustrates a possible arrangement where the arcuate portions of each the continuous groove voids **212** are arranged to form a denser, more packed center region to create more first material land areas than second material land areas. Having a greater amount of first material land areas than second material land area aids in creating a center region that is less responsive to ball impacts than areas toward and at the

heel end or toe ends. This arrangement can be progressive, or asymmetrically arranged from the center to heel end or center to toe end of the striking surface.

[0093] Moving away from the center region toward the heel or toe, the spacing distance between adjacent arcuate portions can increase thereby introducing more second material land areas. This spacing distance can be symmetrically progressive or asymmetrically progressive. This aids in creating a gradually more responsive region away from the center region towards the heel and toe regions. Creating a striking surface with different responses characteristic aids in controlling ball speeds more consistently across the striking surface.

[0094] Additionally, to create a more densely packed center region towards the top rail and sole at the center of the strike face are entirely arcuate recesses (also can be referred to as semi-circle grooves). This further increases the amount (or degree) of first material lands areas that not present moving away from the center and at the heel end and toe end.

[0095] The putter-type golf club head of FIGS. 6-9 comprises a putter-body **201** having a toe portion **202**, a heel portion **203** opposite the toe portion **202**, a top rail portion **204**, a sole portion **205** opposite the top rail portion **204**, a portion of a striking surface **207**, and a rear portion **206** opposite the striking surface portion **207**. The striking surface portion **207** further defines a striking surface recess **223** defined by the heel portion **203**, the toe portion **202**, the top rail portion **204**, the sole portion **205**, and the rear portion **206** of the putter body **201**.

[0096] Referencing FIG.7, FIG. 7 illustrates a perspective view of a putter insert **224**. In many embodiments, the putter insert **224** can be received within and complementary with the striking surface recess **223**. Unlike the embodiment of FIGS. 1-3, where the putter body **201** defines the second material **210**, the second **210** material and the first material **209** are a part of the putter insert **224** (*i.e.* distinct from the putter body **201**).

[0097] The insert **224** can comprise of a front surface **225** adapted for impact with a golf ball (not shown) and a rear surface **226** opposite the front portion. A putter insert

thickness **227** can be defined as the maximum perpendicular distance between the front surface **225** and the rear surface **226**. For example, FIGS. 6 illustrates the insert **224** having a plurality of continuous groove voids **212** (defined by the second material) extending entirely through the second material **210** thickness. In many embodiments, the first material, the second material, and/or the combination of the first and second material can be of a constant thickness.

[0098] Further, in many embodiments, the first material **209** entirely covers the rear surface **226** of the insert **224**. In other words, the rear surface **226** is devoid of the second material **210**. In many embodiments, the first material **209** further fully fills each continuous groove void (until flush with the front surface **225** of the insert) of the pluralities of continuous groove voids, so that at the front surface **225** the second material **210** surrounds the first material **209**, and upon golf ball impact the first material **209** and the second material **210** are engaged to least a portion of the golf ball.

[0099] The plurality of continuous groove voids **212** defined by the putter insert **224** can resemble many shapes or geometries. For example, in this exemplary embodiment, the plurality of continuous groove voids **212** can be defined by one or more continuous curvilinear groove voids, one or more continuous arcuate groove voids (may also be referred to as “continuous arc-like groove voids”), one or more continuous linear groove voids, and/or combinations thereof. In this specific embodiment, the second material **210** defines five continuous arcuate groove voids **213** (or arc-like grooves), one continuous linear groove void **214**, and six continuous groove voids **215** that define both a linear portion and an arcuate portion.

[00100] In alternative embodiments of putter-type golf club heads having continuous arcuate groove voids **213**, the second material **210** can define (or forms) one or more continuous arcuate groove voids **213**, two or more continuous arcuate groove voids **213**, three or more continuous arcuate groove voids **213**, four or more continuous arcuate groove voids **213**, five or more continuous arcuate groove voids **213**, six or more continuous arcuate groove voids **213**, seven or more continuous arcuate groove voids **213**, eight or more continuous arcuate groove voids **213**, nine or more continuous arcuate

groove voids **213**, ten or more continuous arcuate groove voids **213**, or eleven or more continuous arcuate groove voids **213**.

[00101] In the same or other embodiments, the second material **210** can define one or more continuous groove voids that defines a linear portion and an arcuate portion **215**, two or more continuous groove voids that defines a linear portion and an arcuate portion **215**, three or more continuous groove voids that defines a linear portion and an arcuate portion **215**, four or more continuous groove voids that defines a linear portion and an arcuate portion **215**, five or more continuous groove voids that defines a linear portion and an arcuate portion **215**, six or more continuous groove voids that defines a linear portion and an arcuate portion **215**, seven or more continuous groove voids that defines a linear portion and an arcuate portion **215**, eight or more continuous groove voids that defines a linear portion and an arcuate portion **215**, nine or more continuous groove voids that defines a linear portion and an arcuate portion **215**, ten or more continuous groove voids that defines a linear portion and an arcuate portion **215**, or eleven or more continuous groove voids that defines a linear portion and an arcuate portion **215**. In general, the arcuate portions of the continuous linear groove voids **215** are in between a first linear portion (proximal to the heel portion) and a second linear portion (proximal to the toe portion).

[00102] In many embodiments, each continuous groove void of the plurality of continuous groove voids (although not required) comprises either (1) a first end **216** and a second end **217** that can be connected to an upper border **218** of the striking surface **207**, (2) a first end **216** and a second end **217** that can be connected to either the heel **203** or toe portion **202** of the striking surface, or (3) a first end **216** and a second end **217** that can be connected to the lower border **219** of the striking surface **207**. This type of groove void arrangement permits the land area (or second material area **210**) between the groove voids to be finely adjusted without requiring the continuous grooves voids to vary in width or thickness. This aids in achieving a consistent ball speed across the striking surface **207**.

[00103] In some embodiments, the plurality of continuous groove voids are asymmetrical about the centerline axis of the entirely continuous linear groove void **214** that extends from the heel portion **203** to the toe portion **202**. Each of the plurality of continuous groove voids between the entirely continuous linear groove **214** and the upper border **218** (proximal to the top rail **204** of the putter body **201**) of the striking surface **207** can comprise arcuate portions and/or continuous arcuate groove voids **213** that are concave up relative to the upper border **218** of the striking surface **207**. Similarly, each of the plurality of continuous groove voids between the entirely continuous linear groove void **214** and the lower border **219** (proximal to the sole portion **205** of the putter body **201**) of the striking surface **207** can comprise arcuate portions and/or continuous arcuate groove voids that are concave down relative to the lower border **219** of the striking surface **207**.

[00104] Each of the continuous groove voids can have a constant width measured transversely in a top rail **204**-to-sole **205** direction. In many embodiments, the width of each continuous groove voids can range be between 0.020 inch to 0.040 inch. For example, the width of the continuous groove voids can be approximately 0.020 inches, approximately, 0.021 inches, approximately 0.022 inches, approximately 0.023 inches, approximately 0.024 inches, approximately 0.025 inches, approximately 0.026 inches, approximately 0.027 inches, approximately 0.028 inches, approximately 0.029 inches, approximately 0.030 inches, approximately 0.031 inches, approximately 0.032 inches, approximately 0.033 inches, approximately 0.034 inches, approximately 0.035 inches, approximately 0.036 inches, approximately 0.037 inches, approximately 0.038 inches, approximately 0.039 inches, or approximately 0.040 inches.

[00105] In many embodiments, each arcuate portion and/or continuous arcuate groove void **213** of the plurality of continuous groove voids can have a maximum length (measured in a heel **203**-to-toe **202** direction) that is between 1% and 50% of the maximum length of the striking surface **207**. For example, each arcuate portion and/or continuous arcuate groove void of the plurality of continuous groove voids can have a maximum length that is greater than 1% of the striking surface **207**, greater than 5% of the striking surface **207**, greater than 10% of the striking surface **207**, greater than 15% of

the striking surface **207**, greater than 20% of the striking surface **207**, greater than 25% of the striking surface **207**, greater than 30% of the striking surface **207**, greater than 35% of the striking surface **207**, greater than 40% of the striking surface **207**, greater than 45% of striking surface **207**.

[00106] In the same or alternative embodiments, each arcuate portion or continuous arcuate groove void **213** of the plurality of continuous groove voids can have a maximum length that is less than 50% of the striking surface **207**, less than 45% of the striking surface **207**, less than 40% of the striking surface, less than 35% of the striking surface **207**, less than 30% of the striking surface **207**, less than 25% of the striking surface **207**, less than 20% of the striking surface **207**, less than 15% of the striking surface **207**, or less than 10% of the striking surface **207**.

[00107] In other embodiments, each arcuate portion or continuous arcuate groove void **213** of the plurality of continuous groove voids can have a maximum length that is between approximately 1% and approximately 50% of the striking surface **207**, between approximately 1% and approximately 45%, between approximately 1% and approximately 40%, between approximately 1% and 35%, between approximately 1% and approximately 30%, between approximately 1% and approximately 25%, or between approximately 1% and 20% of the maximum length of the striking surface **207**.

[00108] In many embodiments to control the relationship (or ratio) between the first material **209** and the second material **210**, the diameter and arc length of each arcuate groove portion and/or each continuous arcuate groove **213** increases in a direction from the upper border **218** to the entirely continuous linear groove **214**. to create less land areas (or second material land areas) between continuous groove voids at the center region. In the same embodiment or other embodiments, the diameter and arc length of each arcuate portion and/or continuous arcuate grooves increases in a direction from the lower border **219** to the entirely continuous linear groove **214** to create less second material land area areas between continuous groove voids at the center region

[00109] The configuration of each continuous groove voids comprising arcuate portions and/or continuous arcuate groove voids increasing in diameter and/or arc length

from the upper border **218** to the entirely continuous linear groove void **214** and from the lower border **219** to the entirely continuous linear groove void **214** enables the groove voids to have a constant width and depth while achieving a striking surface **207** that can control the ball speed across the striking surface **207**.

[00110] In many of the continuous groove void embodiments, when the club head is in an address position the striking surface comprises a striking surface imaginary vertical axis **220** that extends through a geometric center **208** of the striking surface **207** in a top rail-to-sole direction (as shown by FIG. 9). Further, offset from the striking surface imaginary vertical axis in both a heel **203** and toe **202** direction at 0.25 inch and 0.50 inch are corresponding vertical reference axes.

[00111] As further illustrated in FIG. 9, adjacent continuous groove voids are closer to one another (i.e. packed more closely, creating small land areas (or smaller second material land areas) between continuous grooves voids) along the striking surface imaginary vertical axis **220** than at the vertical reference axis of 0.25 inch **221** and 0.5 inch **222**. Similarly, adjacent continuous groove voids are closer to one another (i.e. packed more closely, smaller land (or second material) area between groove voids) at the vertical reference axis of 0.25 inch **221** than at the vertical reference axis of 0.5 inch **222**.

[00112] In many of the continuous groove void embodiments, the percentage of the first material (or first material land area) along the 0.5-inch vertical reference axis **222** can be between approximately 20% and 40%. For example, the percentage of the first material land area along the 0.5 inch vertical reference axis **222** can be 20%, 21%, 22%, 23%, 24%, 25%, 26%, 27%, 28%, 29%, 30%, 31%, 32%, 33%, 34%, 35%, 36%, 37%, 38%, 39%, or 40%. For further example, the percentage of the first material land area along the 0.5 inch vertical reference axis **222** can be greater than 20%, greater than 21%, greater than 22%, greater than 23%, greater than 24%, greater than 25%, greater than 26%, greater than 27%, greater than 28%, greater than 29%, greater than 30%, greater than 31%, greater than 32%, greater than 33%, greater than 34%, greater than 35%, greater than 36%, greater than 37%, greater than 38%, or greater than 39%. In alternative embodiments, the percentage of the first material land area along the 0.5 inch vertical

reference axis **222** can be less than 21%, less than 22%, less than 23%, less than 24%, less than 25%, less than 26%, less than 27%, less than 28%, less than 29%, less than 30%, less than 31%, less than 32%, less than 33%, less than 34%, less than 35%, less than 36%, less than 37%, less than 38%, less than 39%, or less than 40%,

[00113] In many of the continuous groove embodiments, the percentage of the first material (or first material land area) along the 0.25-inch vertical reference axis **221** can be between approximately 30% and 50%. For example, the percentage of the first material along the 0.25 inch vertical reference axis **221** can be 30%, 31%, 32%, 33%, 34%, 35%, 36%, 37%, 38%, 39%, 40%, 41%, 42%, 43%, 44%, 45%, 46%, 47%, 48%, 49%, or 50%. For further example, the percentage of the first material land area along the 0.25 inch vertical reference axis **221** can be greater than 30%, greater than 31%, greater than 32%, greater than 33%, greater than 34%, greater than 35%, greater than 36%, greater than 37%, greater than 38%, greater than 39%, greater than 40%, greater than 41%, greater than 42%, greater than 43%, greater than 44%, greater than 45%, greater than 46%, greater than 47%, greater than 48%, or greater than 49%. In alternative embodiments, the percentage of the first material land area along the 0.25 inch vertical reference axis **221** can be less than 31%, less than 32%, less than 33%, less than 34%, less than 35%, less than 36%, less than 37%, less than 38%, less than 39%, less than 40%, less than 41%, less than 42%, less than 43%, less than 44%, less than 45%, less than 46%, less than 47%, less than 48%, less than 49%, or less than 50%,

[00114] In many of the continuous groove embodiments, the percentage of the first material (or the first material land area) along the striking surface imaginary axis **220** can be between approximately 40% and 60%. For example, the percentage of the first material along the striking surface imaginary axis **220** can be 40%, 41%, 42%, 43%, 44%, 45%, 46%, 47%, 48%, 49%, 50%, 51%, 52%, 53%, 54%, 55%, 56%, 57%, 58%, 59%, or 60%. For further example, the percentage of the first material along the striking surface imaginary axis **220** can be greater than 40%, greater than 41%, greater than 42%, greater than 43%, greater than 44%, greater than 45%, greater than 46%, greater than 47%, greater than 48%, greater than 49%, greater than 50%, greater than 51%, greater than 52%, greater than 53%, greater than 54%, greater than 55%, greater than 56%, greater

than 57%, greater than 58%, or greater than 59%. In alternative embodiments, the percentage of the first material along the striking surface imaginary axis **220** can be less than 41%, less than 42%, less than 43%, less than 44%, less than 45%, less than 46%, less than 47%, less than 48%, less than 49%, less than 50%, less than 51%, less than 52%, less than 53%, less than 54%, less than 55%, less than 56%, less than 57%, less than 58%, less than 59%, or less than 60%,

[00115] Further, in many embodiments, the average ratio defined as the surface area of the first material land area to the surface area of the second material land area (measured in a top rail-to-sole direction) decreases from the striking surface imaginary vertical axis **220** to the 0.5-inch vertical reference axis **222**. This type of arrangement of the first material and the second material aid in providing consistent ball speeds across the striking surface as the average ratio along the striking surface imaginary vertical axis is greater (i.e. softer) than the average ratio along the 0.5 inch vertical reference axis (i.e. harder). This counteracts the loss of energy transfer on heel and toe mishits.

Discrete Voids (Pill Shape)

[00116] FIGS. 10-13 illustrate another exemplary embodiment. More particularly, FIGS. 10-13 illustrate an example of a putter-type golf club head **300** comprising a dual-material striking surface **307** comprising a first material **309** and a second material **310**. The golf club head **300** of FIGS. 10-13 and the golf club head **200** of FIGS. 6-9 are similar in many respects, except for that the golf club head **300** comprises discrete voids that extend in a heel-to-toe direction rather than continuous voids and/or recesses. The discrete voids generally have a greater length proximate the center region of the striking surface **307** than towards the heel and/or toe. In many embodiments, the discrete voids are substantially the same width.

[00117] FIG. 10 illustrates a putter-type golf club head **300** comprising a putter-body **301** having a toe portion **302**, a heel portion **303** opposite the toe portion **302**, a top rail portion **304**, a sole portion **305** opposite the top rail portion **304**, a portion of a striking surface **307**, and a rear portion **306** opposite the striking surface portion **307**. The striking surface portion **307** can further define a striking surface recess **323** defined by the heel

portion **303**, the toe portion **302**, the top rail portion **304**, the sole portion **305**, and the rear portion **306** of the putter body **301**.

[00118] FIGS. 10 - 13 illustrate a two-part putter insert **324** comprising a first material **309** (also referred to as “first part”) and a second material **310** (also referred to as “second part”). With specific reference to FIG. 10, the second part forms (or defines) a plurality of discrete pill shaped voids **312**. These discrete pill shaped voids are arranged in rows and columns and do not connect or touch another pill shaped void.

[00119] The second part surrounds the pill shaped voids to form second material land areas. The first part of the putter insert **324** comprises a plurality of protruding pill shaped geometries that are complimentary to a corresponding discrete pill shaped void **212**. By coupling the first part and the second part together, the plurality of protruding discrete pill shaped voids can be flush with the second material land areas. Thereby, the plurality of protruding discrete pill shaped voids can form first material land areas. The first material land areas and the second material land engage with at least a portion of the golf ball upon golf ball impact. The first material has a hardness less than the second material.

[00120] This embodiment illustrates a possible arrangement where variable length pill shaped voids are arranged to form a denser, more packed center region creating more first material land areas than second material land areas. Referencing FIG. 12, it can be seen that in any given row the pill shaped voids having the greatest lengths are proximate to the center region and the pill shaped voids having the smallest lengths are proximate the heel and toe ends. This arrangement creates a center region having a greater amount of first material land areas than second material land area (which creates a center region that is less responsive to ball impacts than areas toward and at the heel end or toe ends). In a top rail to sole direction, the first material land areas and the second material land areas are substantially the same or constant. Therefore, the first material land area only varies in a heel to toe direction and not a top rail to sole direction.

[00121] Moving away from the center region toward the heel or toe along a given row, the spacing distance between adjacent discrete pill shaped voids increases (i.e. the length of the discrete pills shaped voids decrease. This creates more second material land areas,

which aids in gradually creating a more responsive region away from the center region towards the heel and toe regions to consistently control ball speeds across the striking surface.

[00122] FIGS. 11-13 illustrates various putter inserts **324** comprising discrete pill shaped voids. In many embodiments, the putter insert **324** can be received within and complementary with the striking surface recess **323**. However, it should be noted in alternative embodiments, the putter-type golf club head **300** need not to be an insert style putter.

[00123] FIG. 13 illustrates an exploded view of the putter insert **324** comprising discrete pill shaped voids. The insert **324** can comprise of a front surface **325** adapted for impact with a golf ball (not shown) and a rear surface **326** opposite the front portion. A putter insert thickness (or depth) **327** can be defined as the maximum perpendicular distance between the front surface **325** and the rear surface **326**. For example, FIG. 13 illustrates the insert **324** having a plurality of discrete pill shaped voids **312** (defined by the second material) extending entirely through the second material **310** thickness (or depth).

[00124] Further, in many embodiments, the first material **309** can entirely cover the rear surface **326** of the insert **324**. In other words, the rear surface **326** is devoid of the second material **310**. In many embodiments, the first material **309** further fills each of the discrete pill shaped voids **312** (until flush with the front surface **325** of the insert) of the pluralities of discrete pill shaped voids, so that at the front surface **325** the second material **310** surrounds the first material **309** and upon golf ball impact the first material **309** and the second material **310** can engage to least a portion of the golf ball.

[00125] Each discrete pill shaped void can have a first end **328** (proximal to the toe) forming an arcuate geometry and a second end **329** (proximal to the heel) forming an arcuate geometry. In many embodiments, the first **328** and second end **329** geometry can be curvilinear, circular, semicircular, crescent like, bow shape, curved, or rounded. The first end **328** and second end **329** can be connected by parallel horizontal segments **330** that extend substantially in a heel-to-toe direction.

[00126] The maximum length of each discrete pill shaped void **312** (measured in a heel-to-toe direction) can vary in a heel-to-toe direction. In many embodiments, the maximum length of each discrete pill shaped **312** void can be between .02 inches and .36 inches. For example, the maximum length of each of the plurality of discrete pill shaped voids **312** can be between 0.02 inches – 0.36 inches, 0.04 inches – 0.36 inches, 0.06 inches – 0.36 inches, 0.08 inches – 0.36 inches, 0.10 inches – 0.36 inches, 0.12 inches – 0.36 inches, 0.14 inches – 0.36 inches, 0.16 inches – 0.36 inches, 0.18 inches – 0.36 inches, 0.20 inches – 0.36 inches, 0.22 inches – 0.36 inches, 0.24 inches – 0.36 inches, 0.26 inches – 0.36 inches, or 0.28 inches – 0.36 inches. In other embodiments, the maximum length of each discrete pill shaped void **312** can vary between 0.06 inch and 0.180 inch.

[00127] The maximum width of each discrete pill shaped void **312** of the plurality of pill shaped voids (measured in a top rail-to-sole direction) can remain the same or substantially constant. In many embodiments, the maximum width of each discrete pill shaped void **312** can be between 0.01 inches and 0.3 inches. For example, the maximum width of each discrete pill shaped void **312** can be greater than 0.01 inches, greater than 0.02 inches, greater than 0.03 inches, greater than 0.04 inches, greater than 0.05 inches, greater than 0.06 inches, greater than 0.07 inches, greater than 0.08 inches, greater than 0.09 inches, greater than 0.10 inches, greater than 0.11 inches, greater than 0.12 inches, greater than 0.13 inches, greater than 0.14 inches, greater than 0.15 inches, greater than 0.16 inches, greater than 0.17 inches, greater than 0.18 inches, greater than 0.19 inches, greater than 0.20 inches, greater than 0.21 inches, greater than 0.22 inches, greater than 0.23 inches, greater than 0.24 inches, greater than 0.25 inches, greater than 0.26 inches, greater than 0.27 inches, greater than 0.28 inches, or greater than 0.29 inches.

[00128] In other embodiments, the maximum width of each discrete pill shaped void **312** can be less than 0.30 inches, less than 0.29 inches, less than 0.28 inches, less than 0.27 inches, less than 0.26 inches, less than 0.25 inches, less than 0.24 inches, less than 0.23 inches, less than 0.22 inches, less than 0.21 inches, less than 0.20 inches, less than 0.19 inches, less than 0.18 inches, less than 0.17 inches, less than 0.16 inches, less than 0.15 inches, less than 0.14 inches, less than 0.13 inches, less than 0.12 inches, less than

0.11 inches, less than 0.10 inches, less than 0.09 inches, less than 0.08 inches, less than 0.07 inches, less than 0.06 inches, less than 0.05 inches, less than 0.04 inches, less than 0.03 inches, or less than 0.02 inches.

[00129] In the same or other discrete pill shaped void **312** embodiments, the plurality of discrete pill shaped voids **312** can be positioned in substantially horizontal rows and/or substantially vertical columns. In the exemplary embodiment of FIG. 11, the plurality of discrete pill shaped voids are arranged to form eleven rows and seventeen columns. In the embodiment of FIG. 12, the plurality of discrete pill shaped voids are arranged to form thirteen rows and seventeen columns. In alternative embodiments, the plurality of discrete pill shaped voids can be arranged to form two or more rows, three or more rows, four or more rows, five or more rows, six or more rows, seven or more rows, eight or more rows, nine or more rows, ten or more rows, eleven or more rows, twelve or more rows, thirteen or more rows, fourteen or more rows, fifteen or more rows, sixteen or more rows, seventeen or more rows, eighteen or more rows, nineteen or more rows, or twenty or more rows. In the same or alternative embodiments, the plurality of discrete pill shaped voids can be arranged to form two or more columns, three or more columns, four or more columns, five or more columns, six or more columns, seven or more columns, eight or more columns, nine or more columns, ten or more columns, eleven or more columns, twelve or more columns, thirteen or more columns, fourteen or more columns, fifteen or more columns, sixteen or more columns, seventeen or more columns, eighteen or more columns, nineteen or more columns, or twenty or more columns. As will be further described below, aligning the pill shaped voids **312** in rows and columns permits the appropriate ratio between the first and second material along a vertical reference axis.

[00130] As can be seen in the exemplary embodiment of FIGS. 10 – 13, each of the plurality of discrete pill shaped voids **312** are spaced from one another in both a heel-to-toe direction and a top rail-to-sole direction. This is dissimilar from the continuous groove or recesses embodiments of FIGS. 1-9 which are continuously connected in the heel-to-toe direction. Each row or column can have two or more discrete pill shaped voids, three or more discrete pill shaped voids, four or more discrete pill shaped voids, five or more discrete pill shaped voids, six or more discrete pill shaped voids, seven or

more discrete pill shaped voids, eight or more discrete pill shaped voids, nine or more discrete pill shaped voids, ten or more discrete pill shaped voids, eleven or more discrete pill shaped voids, twelve or more discrete pill shaped voids, thirteen or more discrete pill shaped voids, fourteen or more discrete pill shaped voids, fifteen or more discrete pill shaped voids, sixteen or more discrete pill shaped voids, seventeen or more discrete pill shaped voids, eighteen or more discrete pill shaped voids, nineteen or more discrete pill shaped voids, or twenty or more discrete pill shaped voids.

[00131] The volume of the first material **309** that fills each discrete pill shaped void **312** can vary in a heel-to-toe direction. In many embodiments, first material **309** can fill a volume between $0.0000803 \text{ in}^3 - 0.00104122 \text{ in}^3$. In some embodiments, the first material **309** can fill a volume between $0.0000803 \text{ in}^3 - 0.00104122 \text{ in}^3$, $0.000176 \text{ in}^3 - 0.00104122 \text{ in}^3$, $0.000272 \text{ in}^3 - 0.00104122 \text{ in}^3$, $0.000368 \text{ in}^3 - 0.00104122 \text{ in}^3$, $0.000464 \text{ in}^3 - 0.00104122 \text{ in}^3$, $0.00056 \text{ in}^3 - 0.00104122 \text{ in}^3$, $0.00065 \text{ in}^3 - 0.00104122 \text{ in}^3$, $0.00075 \text{ in}^3 - 0.0010422 \text{ in}^3$, $0.000849 \text{ in}^3 - 0.0010422 \text{ in}^3$, or $0.000945 \text{ in}^3 - 0.00104 \text{ in}^3$. In other embodiments, the first material **309** can fill a volume between $0.000160 \text{ in}^3 - 0.00052061 \text{ in}^3$. Having the first material **309** fill discrete voids of this size more accurately controls the adjustment resolution between the first material and the second material to create a consistent ball speed across the striking surface and enhanced impact feel and sound.

[00132] In many of the discrete pill shaped void embodiments, when the club head is in an address position the striking surface comprises a striking surface imaginary vertical axis **320** that extends through a geometric center **308** of the striking surface **307** in a top rail-to-sole direction (as shown by FIGS. 11 and 12). Further, offset from the striking surface imaginary vertical axis in both a heel **303** and toe **302** direction at 0.25 inch and 0.50 inch are corresponding vertical reference axes **321**, **322**.

[00133] As further illustrated in FIGS. 11 and 12, adjacent discrete pill shaped voids **312** are closer to one another (i.e. packed more closely, small (second material) land area between discrete voids) along the striking surface imaginary vertical axis **320** in both a horizontal and vertical direction than at the vertical reference axis of 0.25 inch **321** and

0.5 inch **322**. Similarly, adjacent discrete pill shaped voids **312** are closer to one another (i.e. packed more closely, smaller land (or second material) area in both a horizontal and vertical direction between discrete pill shaped voids **312**) at the vertical reference axis of 0.25 inch **321** than at the vertical reference axis of 0.5 inch **322**.

[00134] In many of the discrete pill shaped voids embodiments, the percentage of the first material **309** (or first material land area) along the 0.5-inch vertical reference axis **322** can be between approximately 20% and 40%. For example, the percentage of the first material **309** along the 0.5 inch vertical reference axis **322** can be 20%, 21%, 22%, 23%, 24%, 25%, 26%, 27%, 28%, 29%, 30%, 31%, 32%, 33%, 34%, 35%, 36%, 37%, 38%, 39%, or 40%. For further example, the percentage of the first material along the 0.5 inch vertical reference axis **322** can be greater than 20%, greater than 21%, greater than 22%, greater than 23%, greater than 24%, greater than 25%, greater than 26%, greater than 27%, greater than 28%, greater than 29%, greater than 30%, greater than 31%, greater than 32%, greater than 33%, greater than 34%, greater than 35%, greater than 36%, greater than 37%, greater than 38%, or greater than 39%. In alternative embodiments, the percentage of the first material **309** along the 0.5 inch vertical reference axis **322** can be less than 21%, less than 22%, less than 23%, less than 24%, less than 25%, less than 26%, less than 27%, less than 28%, less than 29%, less than 30%, less than 31%, less than 32%, less than 33%, less than 34%, less than 35%, less than 36%, less than 37%, less than 38%, less than 39%, or less than 40%.

[00135] In many of the discrete pill shaped voids embodiments, the percentage of the first material **309** along the 0.25-inch vertical reference axis **321** can be between approximately 30% and 50%. For example, the percentage of the first material **309** along the 0.25 inch vertical reference axis **321** can be 30%, 31%, 32%, 33%, 34%, 35%, 36%, 37%, 38%, 39%, 40%, 41%, 42%, 43%, 44%, 45%, 46%, 47%, 48%, 49%, or 50%. For further example, the percentage of the first material **309** along the 0.25 inch vertical reference axis **321** can be greater than 30%, greater than 31%, greater than 32%, greater than 33%, greater than 34%, greater than 35%, greater than 36%, greater than 37%, greater than 38%, greater than 39%, greater than 40%, greater than 41%, greater than 42%, greater than 43%, greater than 44%, greater than 45%, greater than 46%, greater

than 47%, greater than 48%, or greater than 49%. In alternative embodiments, the percentage of the first material **309** along the 0.25 inch vertical reference axis **321** can be less than 31%, less than 32%, less than 33%, less than 34%, less than 35%, less than 36%, less than 37%, less than 38%, less than 39%, less than 40%, less than 41%, less than 42%, less than 43%, less than 44%, less than 45%, less than 46%, less than 47%, less than 48%, less than 49%, or less than 50%,

[00136] In many of the discrete pill shaped voids embodiments, the percentage of the first material **309** along the striking surface imaginary axis **320** can be between approximately 40% and 60%. For example, the percentage of the first material **309** along the striking surface imaginary axis can be 40%, 41%, 42%, 43%, 44%, 45%, 46%, 47%, 48%, 49%, 50%, 51%, 52%, 53%, 54%, 55%, 56%, 57%, 58%, 59%, or 60%. For further example, the percentage of the first material **309** along the striking surface imaginary axis **320** can be greater than 40%, greater than 41%, greater than 42%, greater than 43%, greater than 44%, greater than 45%, greater than 46%, greater than 47%, greater than 48%, greater than 49%, greater than 50%, greater than 51%, greater than 52%, greater than 53%, greater than 54%, greater than 55%, greater than 56%, greater than 57%, greater than 58%, or greater than 59%. In alternative embodiments, the percentage of the first material **309** along the striking surface imaginary axis **320** can be less than 41%, less than 42%, less than 43%, less than 44%, less than 45%, less than 46%, less than 47%, less than 48%, less than 49%, less than 50%, less than 51%, less than 52%, less than 53%, less than 54%, less than 55%, less than 56%, less than 57%, less than 58%, less than 59%, or less than 60%,

[00137] Further, in many embodiments, the average ratio defined as the surface area of the first material land area percentage **309** to the surface area of the second material land area percentage **310** (measured along a respective vertical references axis) decreases from the striking surface imaginary vertical axis **320** to the 0.5-inch vertical reference axis **322**. This type of arrangement of the first material and the second material aid in providing consistent ball speeds across the striking surface as the average ratio along the striking surface imaginary vertical axis is greater (i.e. softer) than the average ratio along

the 0.5 inch vertical reference axis. This counteracts the loss of energy transfer on heel and toe mishits.

[00138] Additionally, in this exemplary embodiment, variable width, variable thickness, and/or even variable depth discrete voids are not needed to create consistent ball speeds across the striking surface. Consistent ball speeds are achieved as the discrete pill shaped voids vary in length (in a heel-to-toe direction) creating differing first and second material ratios measured along in a top rail-to-sole direction.

Discrete Voids (Hexagonal Shape)

[00139] FIGS. 14-16 illustrate another exemplary embodiment according to the invention described herein. More particularly, FIGS. 14-16 illustrate an example of a putter-type golf club head **400** comprising a dual-material striking surface **407** comprising a first material **409** and a second material **410**. The golf club head **400** of FIGS. 14-16 and the golf club head **300** of FIGS. 10-13 are similar in many respects, except for that the golf club head **400** comprises discrete voids that are hexagonal in shape rather than pill shaped.

[00140] FIG. 14 illustrates a putter-type golf club head **400** comprising a putter-body **401** having a toe portion **402**, a heel portion **403** opposite the toe portion **402**, a top rail portion **404**, a sole portion **405** opposite the top rail portion **404**, a portion of a striking surface **407**, and a rear portion **406** opposite the striking surface portion **407**. The striking surface portion **407** can further define a striking surface recess **423** defined by the heel portion **403**, the toe portion **402**, the top rail portion **404**, the sole portion **405**, and the rear portion **406** of the putter body **401**.

[00141] FIG. 15 illustrates a two-part putter insert **424** comprising discrete hexagonal voids. In many embodiments, the putter insert **424** can be received within and complementary with the striking surface recess **423**. However, it should be noted in alternative embodiments, the putter-type golf club head **400** need not to be an insert style putter.

[00142] FIGS. 14 - 16 illustrate the putter insert **424** comprising a first material **409** (also can be referred to as “first part”) and a second material **410** (also can be referred to as “second part”). With specific reference to FIG. 15, the second part forms (or defines) a plurality of discrete hexagonal shaped voids **412**. These discrete hexagonal shaped voids are arranged in rows and columns and do not connect (or touch) another hexagonal shaped void. The first material has a hardness less than the second material.

[00143] The second material surrounds the hexagonal shaped void to form second material land areas. The first part of the putter insert **424** comprises a plurality of protruding hexagonal shaped geometries that are complimentary to a corresponding hexagonal pill shaped void **412**. Upon coupling, the first part and the second part together, the plurality of protruding hexagonal shaped voids can be flush with the second material land areas. Thereby, permitting the plurality of protruding discrete hexagonal shaped voids to form first material land areas. The first material land areas and the second material land engage with at least a portion of the golf ball upon golf ball impact.

[00144] This embodiment illustrates one possible arrangement where hexagonal voids are arranged to form a denser, more packed center region creating more first material land areas than second material land areas. Referencing FIG. 16, it can be seen that in any given row the hexagonal shaped voids having the greatest widths are proximate to the center region and the hexagonal shaped voids having the smallest widths are distal from the center region. This arrangement creates a center region having a greater amount of first material land areas than second material land area. This creates a center region that is less responsive to ball impacts relative to heel end or toe regions. In a top rail to sole direction, the widths of the first material land are substantially the same or constant. Therefore, as the widths of the discrete hexagonal voids decreases away from the center region, the ratio between the first material and the second material varies too.

[00145] Moving away from the center region toward the heel or toe along a given row, the spacing distance between adjacent discrete hexagonal shaped voids increases (i.e. the length of the discrete hexagonal shaped voids decrease). This creates more second material land areas, which aids in gradually creating a more responsive region away from

the center region towards the heel and toe regions to consistently control ball speeds across the striking surface.

[00146] With continued reference FIG. 15, FIG.15 illustrates an exploded view of the putter insert **424** comprising discrete hexagonal shaped voids. The insert **424** can comprise of a front surface **425** adapted for impact with a golf ball (not shown) and a rear surface **426** opposite the front portion. A putter insert thickness (*i.e.* depth) **427** can be defined as the maximum perpendicular distance between the front surface **425** and the rear surface **426**. For example, FIGS. 15 illustrates the insert **424** having a plurality of discrete hexagonal voids **412** (defined by the second material) extending entirely through the second material **410** thickness (*i.e.* depth).

[00147] Further, in many embodiments, the first material **409** can entirely cover the rear surface **426** of the insert **424**. In other words, the rear surface **426** is devoid of the second material **410**. In many embodiments, the first material **409** further fills each of the discrete hexagonal voids **412** (until flush with the front surface **425** of the insert) of the pluralities of discrete hexagonal shaped voids, so that at the front surface **425** the second material **410** surrounds the first material **409**, so that upon golf ball impact the first material **409** and the second material **410** can engage to least a portion of the golf ball.

[00148] Each discrete hexagonal shape void can be defined as a six-sided polygon with six internal angles and six vertices. Each internal angle **431** of the six internal angles can be approximately 120 degrees. The internal angles add up to approximately 720 degrees. Each side of the six-sided polygon can be equal or substantially equal in length.

[00149] The maximum length of each discrete hexagonal shaped void **412** (measured in a heel-to-toe direction) can vary in a heel-to-toe direction. In many embodiments, the maximum length of each discrete hexagonal shape **412** void can be between 0.03 inches and 0.40 inches. For example, the maximum length of each of the plurality of discrete hexagonal shaped voids **412** can be between 0.03 inches – 0.40 inches, 0.04 inches – 0.40 inches, 0.05 inches – 0.40 inches, 0.06 inches – 0.40 inches, 0.07 inches – 0.40 inches, 0.08 inches – 0.40 inches, 0.09 inches – 0.40 inches, 0.10 inches – 0.40 inches, 0.11 inches – 0.40 inches, 0.12 inches – 0.40 inches, 0.13 inches – 0.40 inches, 0.14 inches –

0.40 inches, or 0.15 inches – 0.40 inches. In other embodiments, the maximum length of each discrete hexagonal void **412** can vary between 0.074 inches and 0.17 inches.

[00150] In other embodiments, the maximum length of each discrete hexagonal shaped void **412** can be less than 0.30 inches, less than 0.29 inches, less than 0.28 inches, less than 0.27 inches, less than 0.26 inches, less than 0.25 inches, less than 0.24 inches, less than 0.23 inches, less than 0.22 inches, less than 0.21 inches, less than 0.20 inches, less than 0.19 inches, less than 0.18 inches, less than 0.17 inches, less than 0.16 inches, less than 0.15 inches, less than 0.14 inches, less than 0.13 inches, less than 0.12 inches, less than 0.11 inches, less than 0.10 inches, less than 0.09 inches, less than 0.08 inches, less than 0.07 inches, less than 0.06 inches, less than 0.05 inches, or less than 0.04 inches.

[00151] The maximum width of each discrete hexagonal shaped void **412** of the plurality of hexagonal shaped voids (measured in a top rail-to-sole direction) can vary. In many embodiments, the maximum width of each discrete hexagonal shaped void **412** can be between 0.03 inches and 0.40 inches. For example, the maximum width of each discrete hexagonal void **412** can be greater than 0.03 inches, greater than 0.04 inches, greater than 0.05 inches, greater than 0.06 inches, greater than 0.07 inches, greater than 0.08 inches, greater than 0.09 inches, greater than 0.10 inches, greater than 0.11 inches, greater than 0.12 inches, greater than 0.13 inches, greater than 0.14 inches, greater than 0.15 inches, greater than 0.16 inches, greater than 0.17 inches, greater than 0.18 inches, greater than 0.19 inches, or greater than 0.20 inches. In other embodiments, the maximum width of each discrete hexagonal shaped void **412** can be less than 0.20 inches, less than 0.19 inches, less than 0.18 inches, less than 0.17 inches, less than 0.16 inches, less than 0.15 inches, less than 0.14 inches, less than 0.13 inches, less than 0.12 inches, less than 0.11 inches, or less than 0.10 inches.

[00152] In the same or other of discrete hexagonal shaped void **412** embodiments, the plurality of discrete hexagonal shaped voids **412** can be positioned in substantially horizontal rows and/or substantially vertical columns. In the exemplary embodiment of FIG. 16, the plurality of discrete hexagonal shaped voids are arranged to form five rows and thirteen columns. In alternative embodiments, the plurality of discrete hexagonal

shaped voids can be arranged to form two or more rows, three or more rows, four or more rows, five or more rows, six or more rows, seven or more rows, eight or more rows, nine or more rows, ten or more rows, eleven or more rows, twelve or more rows, thirteen or more rows, fourteen or more rows, fifteen or more rows, sixteen or more rows, seventeen or more rows, eighteen or more rows, nineteen or more rows, or twenty or more rows. In the same or alternative embodiments, the plurality of discrete hexagonal shaped voids can be arranged to form two or more columns, three or more columns, four or more columns, five or more columns, six or more columns, seven or more columns, eight or more columns, nine or more columns, ten or more columns, eleven or more columns, twelve or more columns, thirteen or more columns, fourteen or more columns, fifteen or more columns, sixteen or more columns, seventeen or more columns, eighteen or more columns, nineteen or more columns, or twenty or more columns. As will be further described below, aligning the hexagonal shaped voids **412** in rows and columns permits an appropriate ratio between the first and second material along a vertical reference axis.

[00153] As can be seen in the exemplary embodiment of FIGS. 14 – 16, each of the plurality of discrete hexagonal shaped voids **412** are spaced from one another in both a heel-to-toe direction and a top rail-to-sole direction. This is dissimilar from the continuous groove or recesses embodiments of FIGS. 1-9 which are continuously connected in the heel-to-toe direction. Each row or column can have two or more discrete hexagonal shaped voids, three or more discrete hexagonal shaped voids, four or more discrete hexagonal shaped voids, five or more discrete hexagonal shaped voids, six or more discrete hexagonal shaped voids, seven or more discrete hexagonal shaped voids, eight or more discrete hexagonal shaped voids, nine or more discrete hexagonal shaped voids, ten or more discrete hexagonal shaped voids, eleven or more discrete hexagonal shaped voids, twelve or more discrete hexagonal shaped voids, thirteen or more discrete hexagonal shaped voids, fourteen or more discrete hexagonal shaped voids, fifteen or more discrete hexagonal shaped voids, sixteen or more discrete hexagonal shaped voids, seventeen or more discrete hexagonal shaped voids, eighteen or more discrete hexagonal shaped voids, nineteen or more discrete hexagonal shaped voids, or twenty or more discrete hexagonal shaped voids.

[00154] The volume of the first material **409** that fills each discrete hexagonal shaped void **412** can vary in a heel-to-toe direction. In many embodiments, first material **409** can fill a volume between $0.0000803 \text{ in}^3 - 0.004 \text{ in}^3$. In some embodiments, the first material **409** can fill a volume between $0.0000803 \text{ in}^3 - 0.004 \text{ in}^3$, $0.000176 \text{ in}^3 - 0.004 \text{ in}^3$, $0.000272 \text{ in}^3 - 0.004 \text{ in}^3$, $0.000368 \text{ in}^3 - 0.004 \text{ in}^3$, $0.000464 \text{ in}^3 - 0.004 \text{ in}^3$, $0.00056 \text{ in}^3 - 0.004 \text{ in}^3$, $0.00065 \text{ in}^3 - 0.004 \text{ in}^3$, $0.0075 \text{ in}^3 - 0.004 \text{ in}^3$, $0.000849 \text{ in}^3 - 0.004 \text{ in}^3$, or $0.000945 \text{ in}^3 - 0.004 \text{ in}^3$. In other embodiments, the first material **409** can fill a volume between $0.00035 \text{ in}^3 - 0.00187 \text{ in}^3$. Having the first material **409** fill discrete voids of this size more accurately controls the adjustment resolution between the first material and the second material to create a consistent ball speed across the striking surface and enhanced impact feel and sound.

[00155] In many of the discrete hexagonal void embodiments, when the club head is in an address position the striking surface comprises a striking surface imaginary vertical axis **420** that extends through a geometric center **408** of the striking surface **407** in a top rail-to-sole direction (as shown by FIG. 16). Further, offset from the striking surface imaginary vertical axis in both a heel **403** and toe **402** direction at 0.25 inch and 0.50 inch are corresponding vertical reference axes.

[00156] As further illustrated in FIGS. 16, adjacent discrete hexagonal shaped voids **412** are closer to one another (i.e. packed more closely, small (second material) land area between discrete voids) along the striking surface imaginary vertical axis **420** in both a horizontal and vertical direction than at the vertical reference axis of 0.25 inch **421** and 0.5 inch **422**. Similarly, adjacent discrete hexagonal shaped voids **412** are closer to one another (i.e. packed more closely, smaller land (or second material) area in both a horizontal and vertical direction between discrete hexagonal shaped voids **412**) at the vertical reference axis of 0.25 inch **421** than at the vertical reference axis of 0.5 inch **422**.

[00157] In many of the discrete hexagonal shaped voids embodiments, the percentage of the first material **409** along the 0.5-inch vertical reference axis **422** can be between approximately 20% and 40%. For example, the percentage of the first material **409** along the 0.5 inch vertical reference axis **422** can be 20%, 21%, 22%, 23%, 24%, 25%, 26%,

27%, 28%, 29%, 30%, 31%, 32%, 33%, 34%, 35%, 36%, 37%, 38%, 39%, or 40%. For further example, the percentage of the first material along the 0.5 inch vertical reference axis **422** can be greater than 20%, greater than 21%, greater than 22%, greater than 23%, greater than 24%, greater than 25%, greater than 26%, greater than 27%, greater than 28%, greater than 29%, greater than 30%, greater than 31%, greater than 32%, greater than 33%, greater than 34%, greater than 35%, greater than 36%, greater than 37%, greater than 38%, or greater than 39%. In alternative embodiments, the percentage of the first material **409** along the 0.5 inch vertical reference axis **422** can be less than 21%, less than 22%, less than 23%, less than 24%, less than 25%, less than 26%, less than 27%, less than 28%, less than 29%, less than 30%, less than 31%, less than 32%, less than 33%, less than 34%, less than 35%, less than 36%, less than 37%, less than 38%, less than 39%, or less than 40%.

[00158] In many of the discrete hexagonal shaped voids embodiments, the percentage of the first material **409** (or first material land area) along the 0.25-inch vertical reference axis **421** can be between approximately 30% and 50%. For example, the percentage of the first material **409** along the 0.25 inch vertical reference axis **421** can be 30%, 31%, 32%, 33%, 34%, 35%, 36%, 37%, 38%, 39%, 40%, 41%, 42%, 43%, 44%, 45%, 46%, 47%, 48%, 49%, or 50%. For further example, the percentage of the first material **409** along the 0.25 inch vertical reference axis **421** can be greater than 30%, greater than 31%, greater than 32%, greater than 33%, greater than 34%, greater than 35%, greater than 36%, greater than 37%, greater than 38%, greater than 39%, greater than 40%, greater than 41%, greater than 42%, greater than 43%, greater than 44%, greater than 45%, greater than 46%, greater than 47%, greater than 48%, or greater than 49%. In alternative embodiments, the percentage of the first material **409** along the 0.25 inch vertical reference axis **421** can be less than 31%, less than 32%, less than 33%, less than 34%, less than 35%, less than 36%, less than 37%, less than 38%, less than 39%, less than 40%, less than 41%, less than 42%, less than 43%, less than 44%, less than 45%, less than 46%, less than 47%, less than 48%, less than 49%, or less than 50%.

[00159] In many of the discrete hexagonal shaped voids embodiments, the percentage of the first material **409** (or first material land area) along the striking surface imaginary

axis **420** can be between approximately 40% and 60%. For example, the percentage of the first material **409** along the striking surface imaginary axis can be 40%, 41%, 42%, 43%, 44%, 45%, 46%, 47%, 48%, 49%, 50%, 51%, 52%, 53%, 54%, 55%, 56%, 57%, 58%, 59%, or 60%. For further example, the percentage of the first material **409** along the striking surface imaginary axis **420** can be greater than 40%, greater than 41%, greater than 42%, greater than 43%, greater than 44%, greater than 45%, greater than 46%, greater than 47%, greater than 48%, greater than 49%, greater than 50%, greater than 51%, greater than 52%, greater than 53%, greater than 54%, greater than 55%, greater than 56%, greater than 57%, greater than 58%, or greater than 59%. In alternative embodiments, the percentage of the first material **409** along the striking surface imaginary axis **420** can be less than 41%, less than 42%, less than 43%, less than 44%, less than 45%, less than 46%, less than 47%, less than 48%, less than 49%, less than 50%, less than 51%, less than 52%, less than 53%, less than 54%, less than 55%, less than 56%, less than 57%, less than 58%, less than 59%, or less than 60%.

[00160] Further, in many embodiments, the average ratio defined as the surface area of the first material land area percentage **409** to the surface area of the second material land area percentage **410** (measured along a respective vertical references axis) decreases from the striking surface imaginary vertical axis **420** to the 0.5-inch vertical reference axis **422**. This type of arrangement of the first material and the second material aid in providing consistent ball speeds across the striking surface as the average ratio along the striking surface imaginary vertical axis is greater (i.e. softer) than the average ratio along the 0.5 inch vertical reference axis. This counteracts the loss of energy transfer on heel and toe mishits.

[00161] Additionally, in this exemplary embodiment, variable width (in a top rail-to-sole direction along columns) and/or even variable thickness (or depth) discrete voids are not needed to create consistent ball speeds across the striking surface. Consistent ball speeds are achieved as the discrete hexagonal shaped voids vary in length (in a heel-to-toe direction) creating differing first and second material ratios along a vertical direction.

Continuous Grooves (Insert Style Putter)

[00162] FIGS. 17-19 illustrate another exemplary embodiment. More particularly, FIGS. 17-19 illustrate an example of a putter-type golf club head **500** comprising a dual-material striking surface **507** comprising a first material **509** and a second material **510**. The golf club head **500** of FIGS. 17-19 are similar in many respects to the above described embodiments.

[00163] The putter-type golf club head of FIGS. 17-19 comprises a putter-body **501** having a toe portion **502**, a heel portion **503** opposite the toe portion **502**, a top rail portion **504**, a sole portion **505** opposite the top rail portion **504**, a portion of a striking surface **507**, and a rear portion **506** opposite the striking surface portion **507**. The striking surface portion **507** further defines a striking surface recess **523** defined by the heel portion **503**, the toe portion **502**, the top rail portion **504**, the sole portion **505**, and the rear portion **506** of the putter body **501**.

[00164] FIGS. 17 - 19 illustrate a putter insert **524** comprising a first material **509** (can also be referred to as “first part”) and a second material **510** (can also be referred to as “second part”). With specific reference to FIG. 18, the second part forms (or defines) a plurality of continuous groove voids **512** and the second material **510** surrounding the plurality of continuous groove voids can be defined as second material land areas. The first part of the putter insert **524** comprises a plurality of protruding geometries that are complimentary to a corresponding continuous groove void **512**. Upon coupling, the first part and the second part of the insert **524** together, the plurality of protruding geometries can be flush with the second material land areas. Therefore, the plurality of protruding geometries can also form first material land areas. The first material land areas and the second material land can engage with at least a portion of the golf ball upon golf ball impact.

[00165] This embodiment illustrates one possible arrangement where each continuous groove voids **412** defines an upper inflection point and lower inflection point. The upper and lower inflection point are centrally positioned on the striking surface. This allows the maximum width of each of the continuous groove void to be centrally located on the striking surface in a top rail-to-sole direction and a heel-to-toe direction. The first

material has a hardness less than the second material. This creates a denser, more packed center region having more first material land areas than second material land areas. Having a greater amount of first material land areas than second material land area aids in creating a center region that is less responsive to ball impacts than areas toward and at the heel end or toe ends.

[00166] Moving away from the center region in a heel and/or toe direction, the spacing distance between adjacent arcuate portions increases to introduce more second material land areas. This creates a gradually more responsive region from the center region towards the heel and toe regions to control ball speeds more consistently across the striking surface.

[00167] Referencing FIG.18, FIG. 18 illustrates a perspective view of a putter insert **524**. In many embodiments, the putter insert **524** can be received within and complementary with the striking surface recess **523**. The putter insert **524** can comprise of a front surface **525** adapted for impact with a golf ball (not shown) and a rear surface **526** opposite the front portion.

[00168] A putter insert thickness **527** can be defined as the maximum perpendicular distance between the front surface **525** and the rear surface **526**. For example, FIG. 18 illustrates the insert **524** having a plurality of continuous groove voids **512** (defined by the second material) extending entirely through the second material **510** thickness. In many embodiments, the first material, the second material, and/or the combination of the first and second material can be of a constant thickness.

[00169] Further, in many embodiments and as illustrated herein, the first material **509** entirely covers the rear surface **526** of the insert **524**. In other words, the rear surface **526** is devoid of the second material **510**. In many embodiments, the first material **509** further fully fills (or fully occupies) each continuous groove void (until flush with the front surface **525** of the insert) of the pluralities of continuous groove voids, so that at the front surface **525** the second material **510** surrounds the first material **509**, so that upon golf ball impact the first material **509** and the second material **510** are engaged to least a portion of the golf ball.

[00170] The plurality of continuous groove voids **512** defined by the putter insert **524** can resemble many shapes or geometries. For example, in this exemplary embodiment illustrated herein the continuous groove voids **512** extend substantially horizontal in a heel-to-toe direction. Each groove continuous groove **512** of the plurality of continuous grooves **512** defines an upper continuous groove wall **532** proximal to the upper border of the striking surface **518**, a lower continuous groove wall proximal **533** to the lower border of the striking surface **519**, a first continuous groove vertex **534** proximal to the toe portion, and a second continuous groove vertex **535** proximal to the heel portion.

[00171] In many embodiments, the upper continuous groove wall **532** continuously decreases from the striking surface imaginary vertical axis **520** to a first continuous groove vertex **534** and a second continuous vertex **535**. Stated another way, the upper continuous groove wall **532** defines an upper inflection point along the upper continuous groove wall at the striking surface imaginary vertical axis **520** and a lower inflection point along the lower continuous groove wall **533** at the striking surface imaginary axis **520**. At the first end **516** and the second end **517** of the continuous groove voids **512**, the upper continuous groove wall **532** and the lower continuous groove wall **533** meet to define a first continuous groove vertex **534** and a second continuous groove vertex **535**.

[00172] In alternative embodiments of putter-type golf club heads having continuous groove voids **512**, the second material **510** can define one or more continuous groove voids **512**, two or more continuous groove voids **512**, three or more continuous groove voids **512**, four or more continuous groove voids **512**, five or more continuous groove voids **512**, six or more continuous groove voids **512**, seven or more continuous groove voids **512**, eight or more continuous groove voids **512**, nine or more continuous groove voids **512**, ten or more continuous groove voids **512**, or eleven or more continuous groove voids **512**.

[00173] Each of the continuous groove voids can have a maximum width measured at the striking surface imaginary vertical axis **520** in a top rail **504**-to-sole **505** direction. In many embodiments, the maximum width of each continuous groove void **520** can range between 0.020 inch to 0.060 inch. For example, the maximum width of the continuous

groove voids **520** can be approximately 0.020 inches, approximately, 0.021 inches, approximately 0.022 inches, approximately 0.023 inches, approximately 0.024 inches, approximately 0.025 inches, approximately 0.026 inches, approximately 0.027 inches, approximately 0.028 inches, approximately 0.029 inches, approximately 0.030 inches, approximately 0.031 inches, approximately 0.032 inches, approximately 0.033 inches, approximately 0.034 inches, approximately 0.035 inches, approximately 0.036 inches, approximately 0.037 inches, approximately 0.038 inches, approximately 0.039 inches, approximately 0.040 inches, approximately 0.041 inches, approximately 0.042 inches, approximately 0.043 inches, approximately 0.044 inches, approximately 0.045 inches, approximately 0.046 inches, approximately 0.047 inches, approximately 0.048 inches, approximately 0.049 inches, approximately 0.050 inches, approximately 0.051 inches, approximately 0.052 inches, approximately 0.053 inches, approximately 0.054 inches, approximately 0.055 inches, approximately 0.056 inches, approximately 0.057 inches, approximately 0.058 inches, approximately 0.059 inches, or approximately 0.060 inches. The width of the continuous groove voids **512** at the first continuous groove vertex and a second continuous groove are less than 0.0001 inch and preferably 0 inch.

[00174] In many embodiments, each continuous groove void **512** of the plurality of continuous groove voids can have a maximum length (measured in a heel **503**-to-toe **502** direction) that is between 30% and 100% of the maximum length of the striking surface **507**. For example, each continuous groove void of the plurality of continuous groove voids **512** can have a maximum length that is greater than 30% of the striking surface **507**, greater than 35% of the striking surface **507**, greater than 40% of the striking surface **507**, greater than 45% of the striking surface **507**, greater than 50% of the striking surface **507**, greater than 55% of the striking surface **507**, greater than 60% of the striking surface **507**, greater than 65% of the striking surface **507**, greater than 70% of the striking surface **507**, greater than 75% of striking surface **507**, greater than 80% of the striking surface **507**, greater than 85% of the striking surface **507**, greater than 90% of the striking surface **507**, or greater than 95% of the striking surface **507**.

[00175] In many embodiments to control the relationship (or ratio) between the first material **509** and the second material **510**, the width of the continuous groove voids

decreases from the striking surface imaginary vertical axis **520** to a virtually zero width at the first continuous groove vertex and/or from the striking surface imaginary vertical axis to a virtually zero width at the second continuous groove vertex. This type of void geometry accurately controls the amount of land areas (or second material area) between adjacent continuous groove voids in a vertical direction to reached predetermined first material-to-second material thresholds.

[00176] In many of the continuous groove void embodiments and as described above when the club head is an address position the striking surface comprises a striking surface imaginary vertical axis **520** that extends through a geometric center **508** of the striking surface **507** in a top rail-to-sole direction (as shown by FIG. 19). Further, offset from the striking surface imaginary vertical axis in both a heel **503** and toe **502** direction at 0.25 inch and 0.50 inch are corresponding vertical reference axes.

[00177] As further illustrated in FIG. 19, adjacent continuous groove voids are closer to one another (i.e. packed more closely, small land area between grooves) along the striking surface imaginary vertical axis **520** than at the vertical reference axis of 0.25 inch **521** and 0.5 inch **522**. Similarly, adjacent continuous grooves are closer to one another (i.e. packed more closely, smaller land (or second material) area between groove voids) at the vertical reference axis of 0.25 inch **521** than at the vertical reference axis of 0.5 inch **522**.

[00178] In many of the continuous groove void embodiments, the percentage of the first material (or first material land area) along the 0.5-inch vertical reference axis can be between approximately 20% and 40%. For example, the percentage of the first material along the 0.5 inch vertical reference axis can be 20%, 21%, 22%, 23%, 24%, 25%, 26%, 27%, 28%, 29%, 30%, 31%, 32%, 33%, 34%, 35%, 36%, 37%, 38%, 39%, or 40%. For further example, the percentage of the first material along the 0.5 inch vertical reference axis can be greater than 20%, greater than 21%, greater than 22%, greater than 23%, greater than 24%, greater than 25%, greater than 26%, greater than 27%, greater than 28%, greater than 29%, greater than 30%, greater than 31%, greater than 32%, greater than 33%, greater than 34%, greater than 35%, greater than 36%, greater than 37%,

greater than 38%, or greater than 39%. In alternative embodiments, the percentage of the first material along the 0.5 inch vertical reference axis can be less than 21%, less than 22%, less than 23%, less than 24%, less than 25%, less than 26%, less than 27%, less than 28%, less than 29%, less than 30%, less than 31%, less than 32%, less than 33%, less than 34%, less than 35%, less than 36%, less than 37%, less than 38%, less than 39%, or less than 40%,

[00179] In many of the continuous groove embodiments, the percentage of the first material (or first material land area) along the 0.25-inch vertical reference axis can be between approximately 30% and 50%. For example, the percentage of the first material along the 0.25 inch vertical reference axis can be 30%, 31%, 32%, 33%, 34%, 35%, 36%, 37%, 38%, 39%, 40%, 41%, 42%, 43%, 44%, 45%, 46%, 47%, 48%, 49%, or 50%. For further example, the percentage of the first material along the 0.25 inch vertical reference axis can be greater than 30%, greater than 31%, greater than 32%, greater than 33%, greater than 34%, greater than 35%, greater than 36%, greater than 37%, greater than 38%, greater than 39%, greater than 40%, greater than 41%, greater than 42%, greater than 43%, greater than 44%, greater than 45%, greater than 46%, greater than 47%, greater than 48%, or greater than 49%. In alternative embodiments, the percentage of the first material along the 0.25 inch vertical reference axis can be less than 31%, less than 32%, less than 33%, less than 34%, less than 35%, less than 36%, less than 37%, less than 38%, less than 39%, less than 40%, less than 41%, less than 42%, less than 43%, less than 44%, less than 45%, less than 46%, less than 47%, less than 48%, less than 49%, or less than 50%,

[00180] In many of the continuous groove embodiments, the percentage of the first material (or first material land area) along the striking surface imaginary axis can be between approximately 40% and 60%. For example, the percentage of the first material along the striking surface imaginary axis can be 40%, 41%, 42%, 43%, 44%, 45%, 46%, 47%, 48%, 49%, 50%, 51%, 52%, 53%, 54%, 55%, 56%, 57%, 58%, 59%, or 60%. For further example, the percentage of the first material along the striking surface imaginary axis can be greater than 40%, greater than 41%, greater than 42%, greater than 43%, greater than 44%, greater than 45%, greater than 46%, greater than 47%, greater than

48%, greater than 49%, greater than 50%, greater than 51%, greater than 52%, greater than 53%, greater than 54%, greater than 55%, greater than 56%, greater than 57%, greater than 58%, or greater than 59%. In alternative embodiments, the percentage of the first material along the striking surface imaginary axis can be less than 41%, less than 42%, less than 43%, less than 44%, less than 45%, less than 46%, less than 47%, less than 48%, less than 49%, less than 50%, less than 51%, less than 52%, less than 53%, less than 54%, less than 55%, less than 56%, less than 57%, less than 58%, less than 59%, or less than 60%.

[00181] Further, in many embodiments, the average ratio defined as the surface area of the first material land area percentage to the surface area of the second material land area percentage (measured along a respective vertical references axis) decreases from the striking surface imaginary vertical axis to the 0.5-inch vertical reference axis. This type of arrangement of the first material and the second material aid in providing consistent ball speeds across the striking surface as the average ratio along the striking surface imaginary vertical axis is greater (i.e. softer) than the average ratio along the 0.5 inch vertical reference axis. This counteracts the loss of energy transfer on heel and toe mishits.

Discrete Voids (Vertical Radiating Pattern)

[00182] FIGS. 20-23 illustrate another exemplary embodiment. More particularly, FIGS. 20-23 illustrate an example of a putter-type golf club head **600** comprising a dual-material striking surface **607** comprising a first material **609** and a second material **610**. The golf club head **600** of FIGS. 20-23 and the above described golf club heads **100, 200, 300, 400, 500** are similar in many respects, except for that the golf club head **600** comprises discrete voids that extend substantially in a top rail-to-sole direction.

[00183] The putter-type golf club head of FIGS. 20-23 can comprises a putter-body (similar to the above mentioned putter bodies) having a toe portion, a heel portion opposite the toe portion, a top rail portion, a sole portion opposite the top rail portion, a portion of a striking surface, and a rear portion opposite the striking surface portion. The striking surface portion further defines a striking surface recess defined by the heel

portion, the toe portion, the top rail portion, the sole portion, and the rear portion of the putter body.

[00184] FIGS. 20 – 23 illustrate a putter insert **624** comprising a first material **609** (also can be referred to as “first part”) and a second material **610** (also can be referred to as “second part”). With specific reference to FIG. 20, the second part forms (or defines) a plurality of discrete concentric radiating voids **612**. Each of the discrete concentric radiating voids have a common center at the striking surface geometric center **608**.

[00185] The second material substantially surrounds the discrete concentric radiating voids to form second material land areas. The first part of the putter insert **624** comprises a plurality of discrete concentric radiating protrusions that are complimentary to a corresponding discrete concentric radiating void **612**. By coupling, the first part and the second part together, the plurality of protruding discrete concentric radiating voids can be flush with the second material land areas (*i.e.* same planar surface). This allows the plurality of protruding discrete concentric radiating voids to form first material land areas. The first material has a hardness less than the second material. The first material land areas and the second material land engage with at least a portion of the golf ball upon golf ball impact.

[00186] This embodiment illustrates a possible arrangement where the discrete concentric radiating voids are arranged to increase in diameter outwardly and away from the striking surface geometric center **608**. This forms a denser, more packed center region creating more first material land areas than second material land areas. This arrangement creates a center region having a greater amount of first material land areas than second material land area. Thereby, creating a center region that is less responsive to ball impacts relative to heel or toe regions. In a top rail to sole direction and in a heel to toe direction, the widths of the first material land areas are substantially the same or constant.

[00187] Moving away from the center region toward the heel or toe direction, the spacing distance between adjacent discrete concentric radiating voids increases. This creates more second material land areas, which aids in gradually creating a more

responsive region away from the center region towards the heel and toe regions to consistently control ball speeds across the striking surface.

[00188] Referring to FIG. 20, FIG. 20 illustrates a perspective view of a putter insert **624**. In many embodiments, the putter insert **624** can be received within and complementary with the striking surface recess. The putter insert **624** can comprise of a front surface **625** adapted for impact with a golf ball (not shown) and a rear surface **626** opposite the front portion.

[00189] A putter insert thickness **627** can be defined as the maximum perpendicular distance between the front surface **625** and the rear surface **626**. For example, FIG. 20 illustrates the insert **624** having a plurality of discrete concentric radiating voids **612** (defined by the second material) extending entirely through the second material **610** thickness. In many embodiments, the first material, the second material, and/or the combination of the first and second material can be of a constant thickness.

[00190] Further, in many embodiments and as illustrated herein, the first material **609** entirely covers the rear surface **626** of the insert **624**. In other words, the rear surface **626** is devoid of the second material **610**. In many embodiments, the first material **609** further fully fills (or fully occupies) each discrete concentric radiating void (until flush with the front surface **625** of the insert) of the pluralities of discrete concentric radiating voids, so that at the front surface **625** the second material **610** surrounds the first material **609**, so that upon golf ball impact the first material **609** and the second material **610** are engaged to least a portion of the golf ball.

[00191] In many embodiments, a majority of the discrete concentric radiating voids **612** vertically extend in a top rail-to-sole direction and connect to both an upper border **618** of the striking surface **607** and a lower border **619** of the striking surface **607**. In many embodiments, where a discrete concentric radiating void **612** does not connect to the upper or lower border of the striking surface, a strut **636** or a string of struts **636** are needed to connect it directly or indirectly to a discrete concentric radiating void that is connected to an upper and lower border of the striking surface.

[00192] In many embodiments, the discrete concentric radiating voids **612** are concentric about the geometric center of the striking surface and can be either circular or arc-like. In a direction from the geometric center of the striking surface to the toe portion and from the geometric center of the striking surface to the heel portion, the diameter of the discrete concentric radiating voids increases. Stated another way, and in many embodiments, in a direction from the geometric center of the striking surface to the upper border of the striking surface and in a direction the geometric center of the striking surface to the lower border of the striking surface the diameter of the discrete concentric radiating voids increases.

[00193] As can be seen by FIGS. 20-23, not all the discrete concentric voids directly connect to the upper and lower border of the striking surface. To ensure that the first material fills the discrete concentric voids in the course of a manufacturing process (i.e. molding), the discrete concentric voids that do not directly connect to the upper and lower border of the striking surface, one or more struts **636** are needed. As can be seen by a combination of FIGS. 22 and 23, a plurality of struts are recessed inwardly from the front surface **625** of the striking surface **607**. These struts enable the discrete concentric voids that are not connected to the upper and lower border of the striking surface to be indirectly connected to one or more discrete concentric voids connected to the upper and lower border of the striking surface.

[00194] In alternative embodiments of putter-type golf club heads having discrete concentric radiating voids **612**, the second material **610** can define one or more discrete concentric radiating voids **612**, two or more discrete concentric radiating voids **612**, three or more discrete concentric radiating voids **612**, four or more discrete concentric radiating voids **612**, five or more discrete concentric radiating voids **612**, six or more discrete concentric radiating voids **612**, seven or more discrete concentric radiating voids **612**, eight or more discrete concentric radiating voids **612**, nine or more discrete concentric radiating voids **612**, ten or more discrete concentric radiating voids **612**, or eleven or more discrete concentric radiating voids **612**, twelve or more discrete concentric radiating voids **612**, thirteen or more discrete concentric radiating voids **612**, fourteen or more discrete concentric radiating voids **612**, fifteen or more discrete

concentric radiating voids **612**, sixteen or more discrete concentric radiating voids **612**, seventeen or more discrete concentric radiating voids **612**, eighteen or more discrete concentric radiating voids **612**, nineteen or more discrete concentric radiating voids **612**, twenty or more discrete concentric radiating voids **612**, twenty-one or more discrete concentric radiating voids **612**, twenty-two or more discrete concentric radiating voids **612**, twenty-three or more discrete concentric radiating voids **612**, twenty-four or more discrete concentric radiating voids **612**, twenty-five or discrete concentric radiating voids **612**, twenty-six or more discrete concentric radiating voids **612**, twenty-seven or more discrete concentric radiating voids **612**, twenty-eight or more discrete concentric radiating voids **612**, twenty-nine or more discrete concentric radiating voids **612**, or thirty or more discrete concentric radiating voids **612**.

[00195] Each of the discrete concentric radiating voids **612** can have a constant width measured transversely in a heel-to-toe direction. In many embodiments, the width of the plurality of discrete concentric radiating voids can range between 0.020 inch to 0.060 inch. For example, the width of the plurality of discrete concentric radiating voids **612** can be approximately 0.020 inches, approximately 0.021 inches, approximately 0.022 inches, approximately 0.023 inches, approximately 0.024 inches, approximately 0.025 inches, approximately 0.026 inches, approximately 0.027 inches, approximately 0.028 inches, approximately 0.029 inches, approximately 0.030 inches, approximately 0.031 inches, approximately 0.032 inches, approximately 0.033 inches, approximately 0.034 inches, approximately 0.035 inches, approximately 0.036 inches, approximately 0.037 inches, approximately 0.038 inches, approximately 0.039 inches, approximately 0.040 inches, approximately 0.041 inches, approximately 0.042 inches, approximately 0.043 inches, approximately 0.044 inches, approximately 0.045 inches, approximately 0.046 inches, approximately 0.047 inches, approximately 0.048 inches, approximately 0.049 inches, approximately 0.050 inches, approximately 0.051 inches, approximately 0.052 inches, approximately 0.053 inches, approximately 0.054 inches, approximately 0.055 inches, approximately 0.056 inches, approximately 0.057 inches, approximately 0.058 inches, approximately 0.059 inches, or approximately 0.060 inches. As will be further seen in the Examples section, variable width, variable depth, and or variable thickness voids are not required to achieve a consistent ball speed across the striking surface **607**.

[00196] In many of the discrete concentric radiating void embodiments and as described above when the club head is an address position the striking surface comprises a striking surface imaginary vertical axis **620** that extends through a geometric center **608** of the striking surface **607** in a top rail-to-sole direction (as shown by FIG. 21). Further, offset from the striking surface imaginary vertical axis in both a heel **603** and toe **602** direction at 0.25 inch and 0.50 inch are corresponding vertical reference axes.

[00197] As further illustrated in FIG. 21, adjacent discrete concentric radiating voids are closer to one another (i.e. packed more closely, small land area (or second material) area between voids) along the striking surface imaginary vertical axis **620** than at the vertical reference axis of 0.25 inch **621** and 0.5 inch **622**. Similarly, adjacent discrete concentric radiating voids are closer to one another (i.e. packed more closely, smaller land (or second material) area between voids) at the vertical reference axis of 0.25 inch **621** than at the vertical reference axis of 0.5 inch **622**.

[00198] In many of the discrete concentric radiating voids embodiments, the percentage of the first material (or first material land area) along the 0.5-inch vertical reference axis can be between approximately 20% and 40%. For example, the percentage of the first material along the 0.5 inch vertical reference axis can be 20%, 21%, 22%, 23%, 24%, 25%, 26%, 27%, 28%, 29%, 30%, 31%, 32%, 33%, 34%, 35%, 36%, 37%, 38%, 39%, or 40%. For further example, the percentage of the first material along the 0.5 inch vertical reference axis can be greater than 20%, greater than 21%, greater than 22%, greater than 23%, greater than 24%, greater than 25%, greater than 26%, greater than 27%, greater than 28%, greater than 29%, greater than 30%, greater than 31%, greater than 32%, greater than 33%, greater than 34%, greater than 35%, greater than 36%, greater than 37%, greater than 38%, or greater than 39%. In alternative embodiments, the percentage of the first material along the 0.5 inch vertical reference axis can be less than 21%, less than 22%, less than 23%, less than 24%, less than 25%, less than 26%, less than 27%, less than 28%, less than 29%, less than 30%, less than 31%, less than 32%, less than 33%, less than 34%, less than 35%, less than 36%, less than 37%, less than 38%, less than 39%, or less than 40%.

[00199] In many of the discrete concentric radiating voids, the percentage of the first material (or first material land area) along the 0.25-inch vertical reference axis can be between approximately 30% and 50%. For example, the percentage of the first material along the 0.25 inch vertical reference axis can be 30%, 31%, 32%, 33%, 34%, 35%, 36%, 37%, 38%, 39%, 40%, 41%, 42%, 43%, 44%, 45%, 46%, 47%, 48%, 49%, or 50%. For further example, the percentage of the first material along the 0.25 inch vertical reference axis can be greater than 30%, greater than 31%, greater than 32%, greater than 33%, greater than 34%, greater than 35%, greater than 36%, greater than 37%, greater than 38%, greater than 39%, greater than 40%, greater than 41%, greater than 42%, greater than 43%, greater than 44%, greater than 45%, greater than 46%, greater than 47%, greater than 48%, or greater than 49%. In alternative embodiments, the percentage of the first material along the 0.25 inch vertical reference axis can be less than 31%, less than 32%, less than 33%, less than 34%, less than 35%, less than 36%, less than 37%, less than 38%, less than 39%, less than 40%, less than 41%, less than 42%, less than 43%, less than 44%, less than 45%, less than 46%, less than 47%, less than 48%, less than 49%, or less than 50%.

[00200] In many of the discrete concentric radiating voids embodiments, the percentage of the first material (or first material land area) along the striking surface imaginary axis can be between approximately 40% and 60%. For example, the percentage of the first material along the striking surface imaginary axis can be 40%, 41%, 42%, 43%, 44%, 45%, 46%, 47%, 48%, 49%, 50%, 51%, 52%, 53%, 54%, 55%, 56%, 57%, 58%, 59%, or 60%. For further example, the percentage of the first material along the striking surface imaginary axis can be greater than 40%, greater than 41%, greater than 42%, greater than 43%, greater than 44%, greater than 45%, greater than 46%, greater than 47%, greater than 48%, greater than 49%, greater than 50%, greater than 51%, greater than 52%, greater than 53%, greater than 54%, greater than 55%, greater than 56%, greater than 57%, greater than 58%, or greater than 59%. In alternative embodiments, the percentage of the first material along the striking surface imaginary axis can be less than 41%, less than 42%, less than 43%, less than 44%, less than 45%, less than 46%, less than 47%, less than 48%, less than 49%, less than 50%, less than 51%, less than 52%,

less than 53%, less than 54%, less than 55%, less than 56%, less than 57%, less than 58%, less than 59%, or less than 60%,

[00201] Further, in many embodiments, the average ratio defined as the surface area of the first material land area percentage to the surface area of the second material land area percentage (measured along a respective vertical references axis) decreases from the striking surface imaginary vertical axis to the 0.5-inch vertical reference axis. This type of arrangement of the first material and the second material aid in providing consistent ball speeds across the striking surface as the average ratio along the striking surface imaginary vertical axis is greater (i.e. softer) than the average ratio along the 0.5 inch vertical reference axis. This counteracts the loss of energy transfer on heel and toe mishits.

Example 1

[00202] Example 1 shows that to select a threshold or desired ball speed across the striking surface, that both the length of the putt and the vertical land area percentage are important factors to consider. This Example generally corresponds to the continuous groove embodiments of FIGS. 1-9.

[00203] FIG. 4 illustrates a seven variable gradient map that details for various impact locations the vertical required land area percentage (or percentage of the second material) needed to achieve a consistent ball speed for putts of approximately 10 ft in length. For example, if a desired ball speed for a 10 ft putt of 5.15 mph is desired, the second material vertical land area percentage at the 0.5 inch vertical reference axis **122** offset from the striking surface imaginary vertical axis **120** is approximately 76%. The second material vertical land area percentage at the 0.25 inch vertical reference axis **121** offset from the striking surface imaginary vertical axis **122** is approximately 58%. The second material vertical land area percentage at the striking surface imaginary vertical axis **120** is approximately 53%.

[00204] If a desired ball speed for a 10 ft putt of 5.10 mph is desired, the second material vertical land area percentage at the 0.5 inch vertical reference axis **122** offset from the striking surface imaginary vertical axis **120** is approximately 73%. The second

material vertical land area percentage at the 0.25 inch vertical reference axis **121** offset from the striking surface imaginary vertical axis **120** is approximately 55%. The second material vertical land area percentage at the striking surface imaginary vertical axis **120** is approximately 50%.

[00205] If a desired ball speed for a 10 ft putt of 5.05 mph is desired, the second material vertical land area percentage at the 0.5 inch vertical reference axis **122** offset from the striking surface imaginary vertical axis **120** is approximately 67%. The second material vertical land area percentage at the 0.25 inch vertical reference axis **121** offset from the striking surface imaginary vertical axis **120** is approximately 50%. The second material vertical land area percentage at the striking surface imaginary vertical axis **120** is approximately 46%.

[00206] For further example, FIG. 5 illustrates another seven variable gradient map that details for various impact locations the required land area needed to achieve a consistent ball speed for putts of approximately 25 feet in length. If a desired ball speed for a 25 ft putt of 7.73 mph is desired, the second material vertical land area percentage at the 0.5 inch vertical reference axis **122** laterally offset from the striking surface imaginary vertical axis **120** is approximately 65%. The second material vertical land area percentage at the 0.25 inch vertical reference axis **121** laterally offset from the striking surface imaginary vertical axis **120** is approximately 58%. The second material vertical land area percentage at the striking surface imaginary vertical axis **120** is approximately 55%.

[00207] If a desired ball speed for a 25 ft putt of 7.68 mph is desired, the second material vertical land area percentage at the 0.5 inch vertical reference axis **122** laterally offset from the striking surface imaginary vertical axis **120** is approximately 60%. The second material vertical land area percentage at the 0.25 inch vertical reference axis **121** laterally offset from the striking surface imaginary vertical axis **120** is approximately 56%. The second material vertical land area percentage at the striking surface imaginary vertical axis **120** is 53%.

[00208] If a desired ball speed for a 25 ft putt of 7.60 mph is desired, the second material vertical land area percentage at the 0.5 inch vertical reference axis **122** laterally offset from the striking surface imaginary vertical axis **120** is approximately 55%. The second material vertical land area percentage at the 0.25 inch vertical reference axis **121** laterally offset from the striking surface imaginary vertical axis **120** is approximately 51%. The second material vertical land area percentage at the striking surface imaginary vertical axis **120** is approximately 48%.

[00209] The seven variable gradient map of FIG.4 and FIG. 5 are based upon the second material being generally composed of metal, for example, 17-4 stainless steel and the first material being generally composed of air. The percentage or relationship between the first material and the second material will vary based upon the type of selected material but the application of controlling the ratio or relationship between the first material and the second material still applies to achieve consistent ball speed.

Example 2

[00210] For many of the above described embodiments, the first material hardness and first material land area percentage characteristics were altered to fully understand the effect that these variables have on ball speed. Specifically, a putter-pendulum test was conducted to measure the ball speed for ten putters. The below table illustrates the material characteristics of the exemplary striking surface tested. Ball speed data was captured at the striking surface imaginary vertical axis, at the heel vertical reference axis at 0.5 inches, and at the toe vertical reference axis at 0.5 inches.

[00211] The exemplary striking surfaces were further benchmarked against a first commercialized putter with polymer fill grooves but grooves not having less groove spacing in the center (Putter 1), a second commercialized putter having a groove concentration greater in the middle but devoid of a second material (Putter 2), and a third commercialized putter having a striking surface devoid of grooves (Putter 3). The results can be seen in FIGS. 24 - 26 and the data was plotted as a percentage of ball speed relative to its own center for 10 ft putts, 25 ft putts, and 40 ft putts.

TABLE 1

Putter	Second Material Hardness	First Material Hardness	Percentage of First Material Land Area @ the heel vertical reference axis at 0.5 inch	Percentage of First Material Land Area @ the heel vertical reference axis at 0.25 inch	Percentage of First Material Land Area @ the striking surface imaginary vertical axis	Percentage of First Material Land Area @ the toe vertical reference axis at 0.25 inch	Percentage of First Material Land Area @ the toe vertical reference axis at 0.5 inch
<i>Discrete Voids (Hexagonal Shape)</i>	85 D	50 A	31%	47%	55%	47%	31%
<i>Discrete Voids (Pill Shape) Rev 2</i>	85 D	80 A	32%	36%	42%	36%	32%
<i>Discrete Voids (Pill Shape) Rev 3a</i>	85 D	40 A	30%	44%	53%	44%	30%
<i>Discrete Voids (Pill Shape) Rev 3b</i>	85 D	90-95 A	30%	44%	53%	44%	30%
<i>Discrete Voids (Pill Shape) Rev 4</i>	85 D	65 A	30%	41%	49%	41%	30%
<i>Discrete Voids (Circular Shape)</i>	85 D	64 A	32%	41%	49%	41%	32%

<i>Continuous Grooves (Insert Style Putter)</i>	85 D	63 A	32%	41%	49%	41%	32%

[00212] The results show that the first material hardness, the second material hardness, and the percentage of the first material along a vertical references axis at specified locations are important factors to consider when a uniform ball speed across a striking surface is desired. For example, when comparing the Discrete Voids (Pill Shaped) Rev 3A and the Discrete Voids (Pill Shaped) Rev 3B putter characteristics, it can be seen that the putters were built the same except for the first material hardness being different. In a 25 ft putt comparison, it can be seen that ball speed on heel and toe hits (relative to center impacts) on the Discrete Voids (Pill Shaped) Rev 3A putter varied approximately 1.6% more than the ball speed produced at the striking surface center. However, the Discrete Voids (Pill Shaped) Rev 3B putter varied no more than 0.8% than the ball speed produced at the center of the striking surface. This led to the conclusion that the relationship/difference between the first material and the second material hardness is an important factor to consider to effectively control ball speeds.

[00213] Additionally, this example led to the conclusion that the percentage of the first material along a vertical reference axis (at specified locations) matters. For example, when comparing the Discrete Voids (Pill Shaped) Rev 4 Putter and the Discrete Voids (Circular Shape) Putter, the first and second material hardness’s were substantially the same, but the percentage of the first material along the striking surface varied. Upon off-center impacts, the Discrete Voids (Pill Shaped) Rev 4 Putter varied no more than 0.4% than the ball speed produced at the striking surface center. The Discrete Voids (Circular Shaped) varied approximately 0.8% upon off center strikes when compared to the ball

speed produced at the striking surface center. Therefore, when controlling ball speed produced across the striking surface, the percentage of the first material along a vertical reference axis is another important variable to help create an even heel-to-toe hitting surface.

CLAIMS

1. A putter-type golf club head comprising:
a body comprising:
 - a heel portion;
 - a toe portion distal from the heel portion;
 - a top rail;
 - a sole portion distal from the top rail; and
 - a striking surface forming a recess defined by the heel portion, the toe portion, the top rail, and the sole portion of the body;
 - a striking surface imaginary vertical axis that extends through a geometric center of the striking surface relative to the heel portion, the toe portion, the top rail, and the sole portion; and
 - an insert configured to be received within and complimentary with the recess defined by the striking surface;
 - wherein:
 - the insert comprises a first material and a second material forming at least one of a front surface adapted for impact with a golf ball, a rear surface opposite the front portion, and a thickness defined as the distance between the front surface and the rear surface;
 - the insert further defines a plurality of pill-shaped voids that extends throughout the entirety of the second material putter insert thickness;
 - each pill-shaped void of the plurality of pill-shaped voids are colinear with one another in a top rail-to-sole portion direction and a heel portion-to-toe portion direction; and
 - the volume of the pill-shaped recesses decreases from the striking surface imaginary vertical axis to one of the heel portion or the toe portion of the body.
2. The putter-type golf club head of claim 1, wherein the first material of the insert entirely covers the rear surface of the insert and fills each pill-shaped void of the plurality of pill-shaped voids.
3. The putter-type golf club head of claim 2, wherein the maximum length measured in a heel-to-direction of each pill-shaped void decreases from the striking surface imaginary axis to one of the heel portion or the toe portion of the body.

4. The putter-type golf club head of claim 3, wherein an average ratio defined as the surface area percentage of a first material land area percentage to a surface area percentage of the second material decreases from the striking surface imaginary vertical axis to a second imaginary vertical axis offset from the striking surface imaginary vertical axis.
5. The putter-type golf club head of claim 4, wherein at the front surface of the insert, the second material surrounds the first material, such that upon impact with a golf ball the first material and the second material are engaged to at least a portion of the golf ball.
6. The putter-type golf club head of claim 5, wherein the first material has a hardness between Shore 30A and Shore 95A.
7. The putter-type golf club head of claim 1, wherein the first material fills a volume for each pill-shaped void between 0.0000803 in^3 - 0.00104122 in^3 .
8. The putter-type golf club head of claim 6, wherein the density of the first material and the second material are substantially the same.
9. The putter-type golf club head of claim 1, wherein the maximum length of each discrete pill shaped void measured in a heel-to-toe direction decreases from the striking surface imaginary vertical axis to at least one of the heel portion or the toe portion and wherein the length is between approximately 0.01 inches and approximately 0.3 inches.
10. A putter-type golf club head comprising:
 - a body comprising:
 - a heel portion;
 - a toe portion distal from the heel portion;
 - a top rail;
 - a sole portion distal from the top rail; and
 - a striking surface forming a recess defined by the heel portion, the toe portion, the top rail, and the sole portion of the body;

a striking surface imaginary vertical axis that extends through a geometric center of the striking surface relative to the heel portion, the toe portion, the top rail, and the sole portion; and an insert configured to be received within and complimentary with the recess defined by the striking surface;

wherein:

the insert comprises a first material and a second material forming at least one of a front surface adapted for impact with a golf ball, a rear surface opposite the front portion, and a thickness defined as the distance between the front surface and the rear surface;

the insert further defines a plurality of pill-shaped voids that extends through a portion of the putter insert thickness;

each pill-shaped void of the plurality of pill-shaped voids are colinear with one another in a top rail-to-sole portion direction and a heel portion-to-toe portion direction; and

the volume of the pill-shaped recesses decreases from the striking surface imaginary vertical axis towards the heel portion and the toe portion of the body.

11. The putter-type golf club head of claim 10, wherein the first material of the insert entirely covers the rear surface of the insert and fills each pill-shaped void of the plurality of pill-shaped voids.
12. The putter-type golf club head of claim 11, wherein the maximum length measured in a heel-to-direction of each pill-shaped void decreases away from the striking surface imaginary axis.
13. The putter-type golf club head of claim 12, wherein an average ratio defined as the surface area percentage of the first material land area to the surface area percentage of the hard material land area decreases from the striking surface imaginary vertical axis to a second imaginary vertical axis offset from the striking surface imaginary vertical axis.
14. The putter-type golf club head of claim 13, wherein at the front surface of the insert, the second material surrounds the first material, such that upon impact with a golf ball the first material and the second material are engaged to at least a portion of the golf ball.

15. The putter putter-type golf club head of claim 14, wherein the first material has a hardness between Shore 30A and Shore 95A.
16. The putter-type golf club head of claim 10, wherein the first material fills a volume for each pill-shaped void between 0.0000803 in^3 - 0.00104122 in^3 .
17. The putter-type golf club head of claim 15, wherein the density of the first material and the second material are substantially the same.
18. The putter-type golf club head of claim 1, wherein the maximum length of each discrete pill shaped void measured in a heel-to-toe direction decreases from the striking surface imaginary vertical axis to at least one of the heel portion or the toe portion and wherein the length is between 0.01 inches and 0.3 inches.
19. The putter-type golf club head of claim 10, wherein the putter-type golf club head has a loft angle less than 5 degrees.
20. The putter-type golf club head of claim 10, wherein the putter insert thickness is substantially constant across the entire insert.

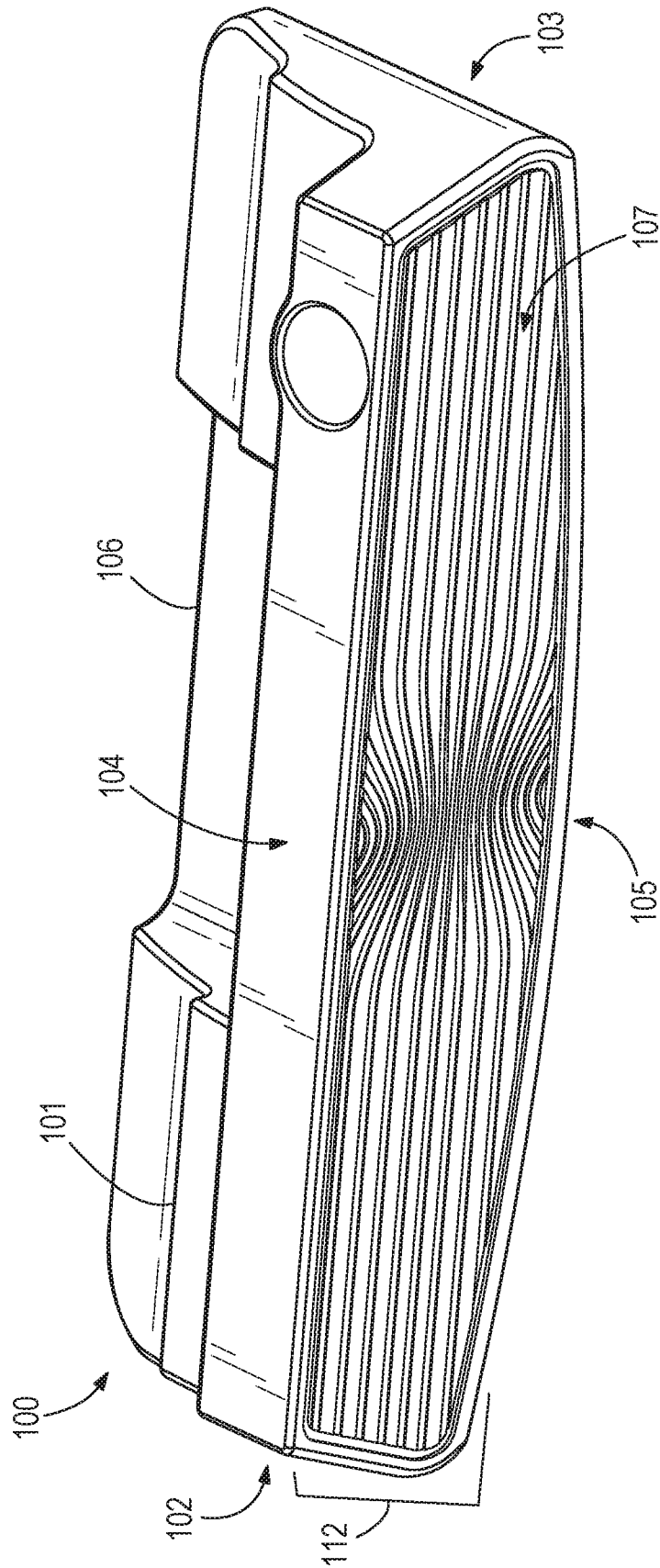
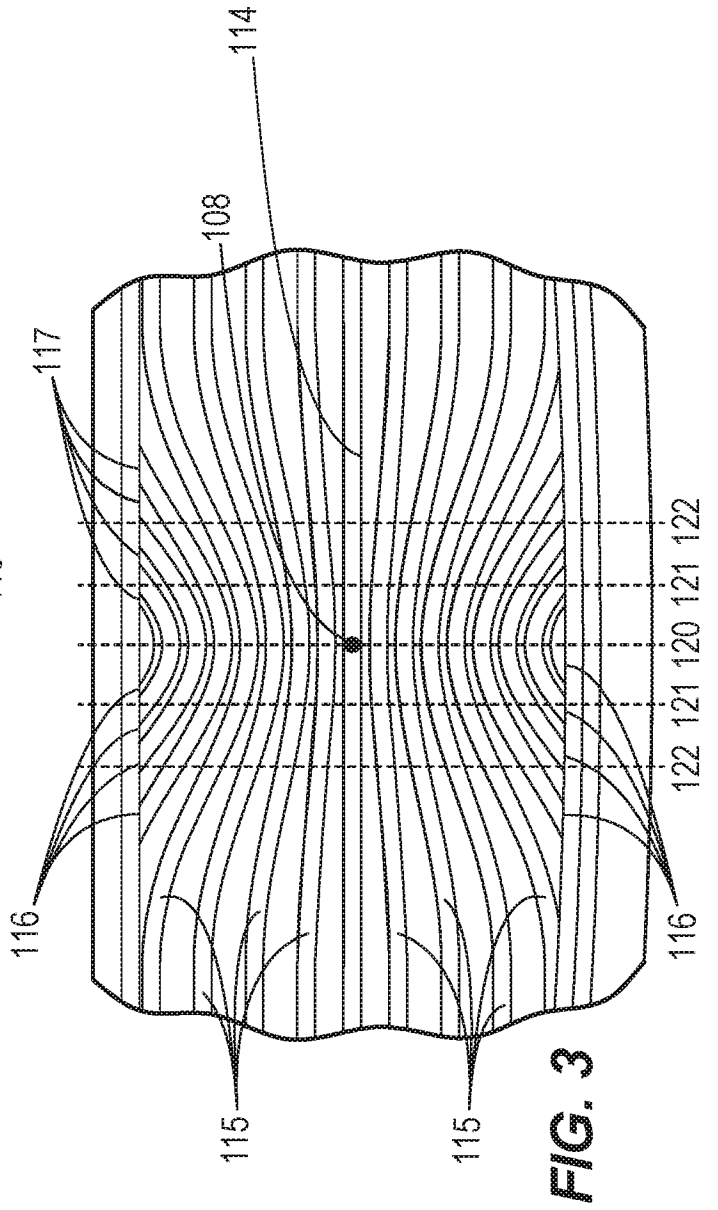
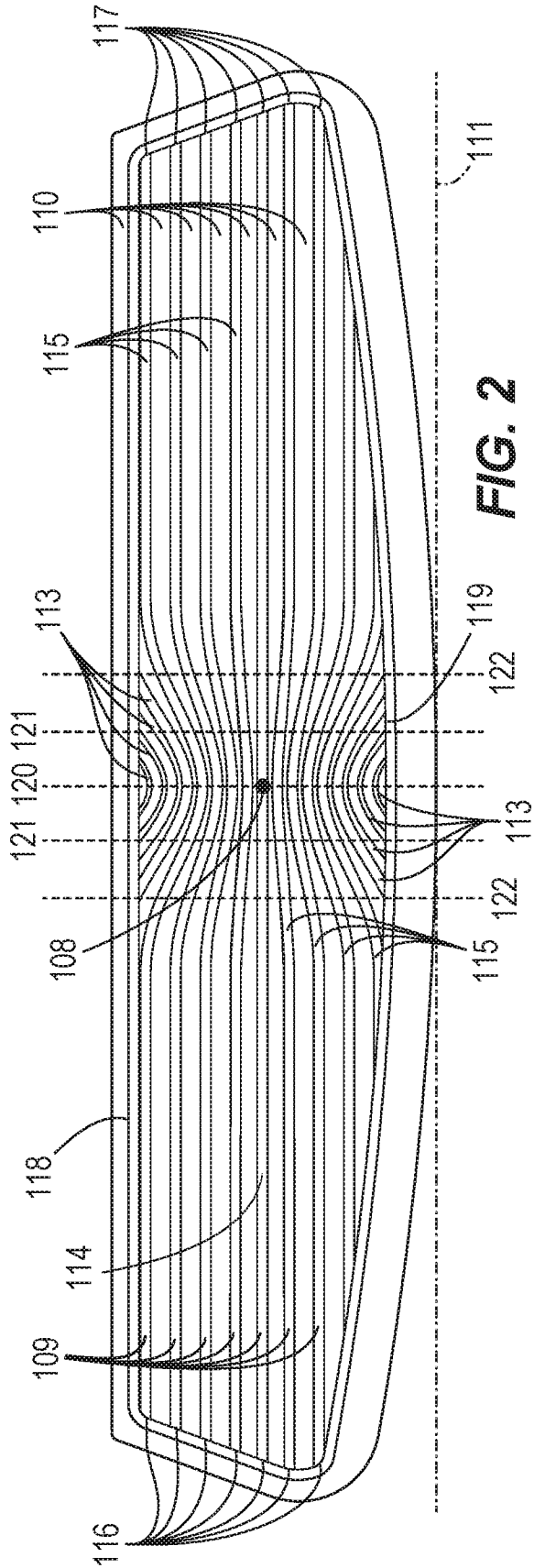

FIG. 1



3/17

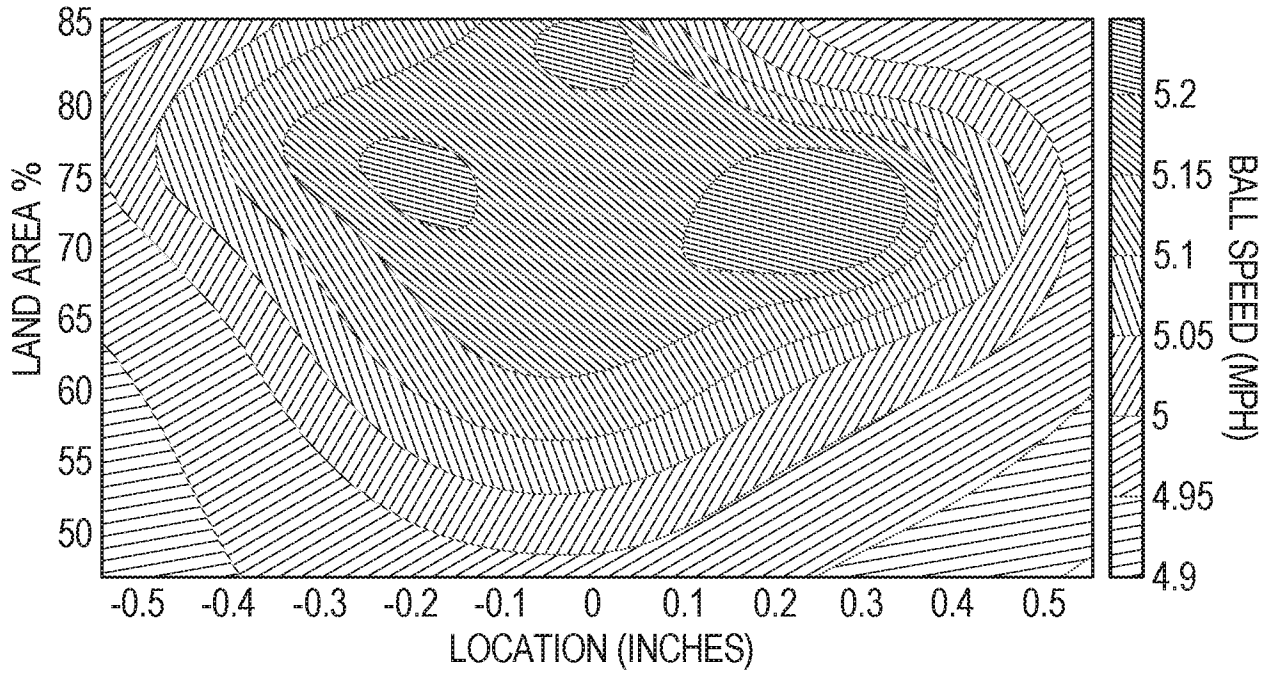

FIG. 4

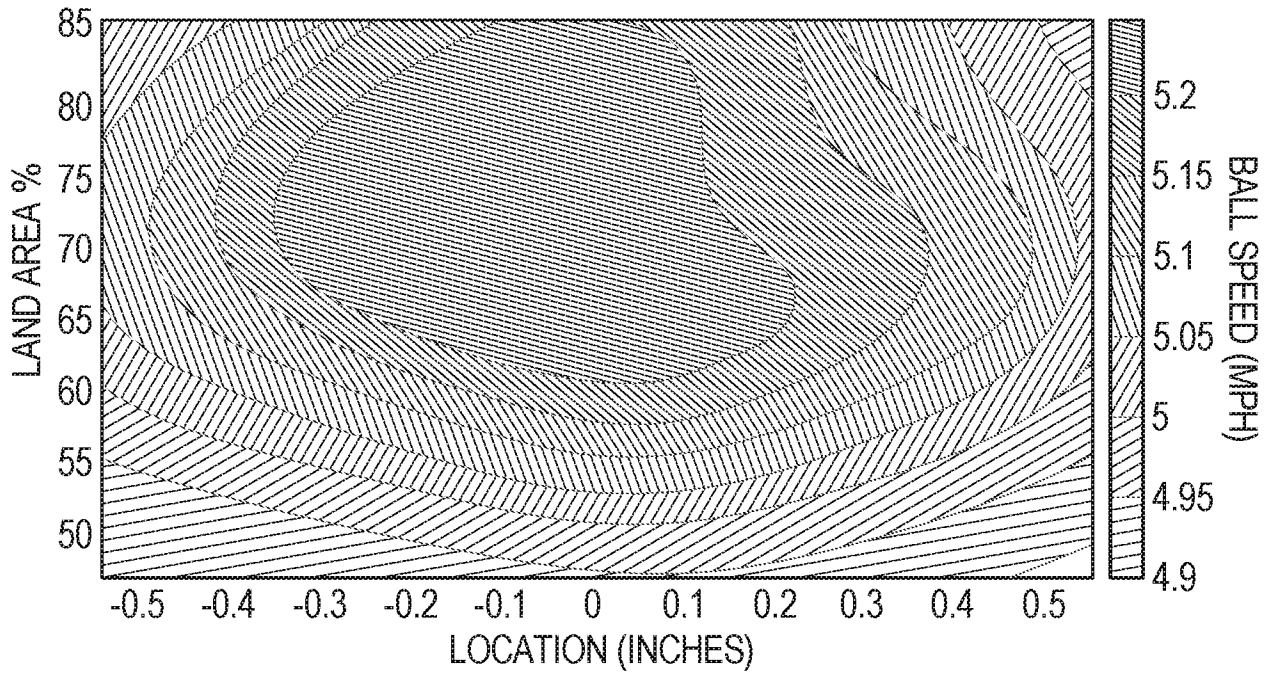

FIG. 5

4/17

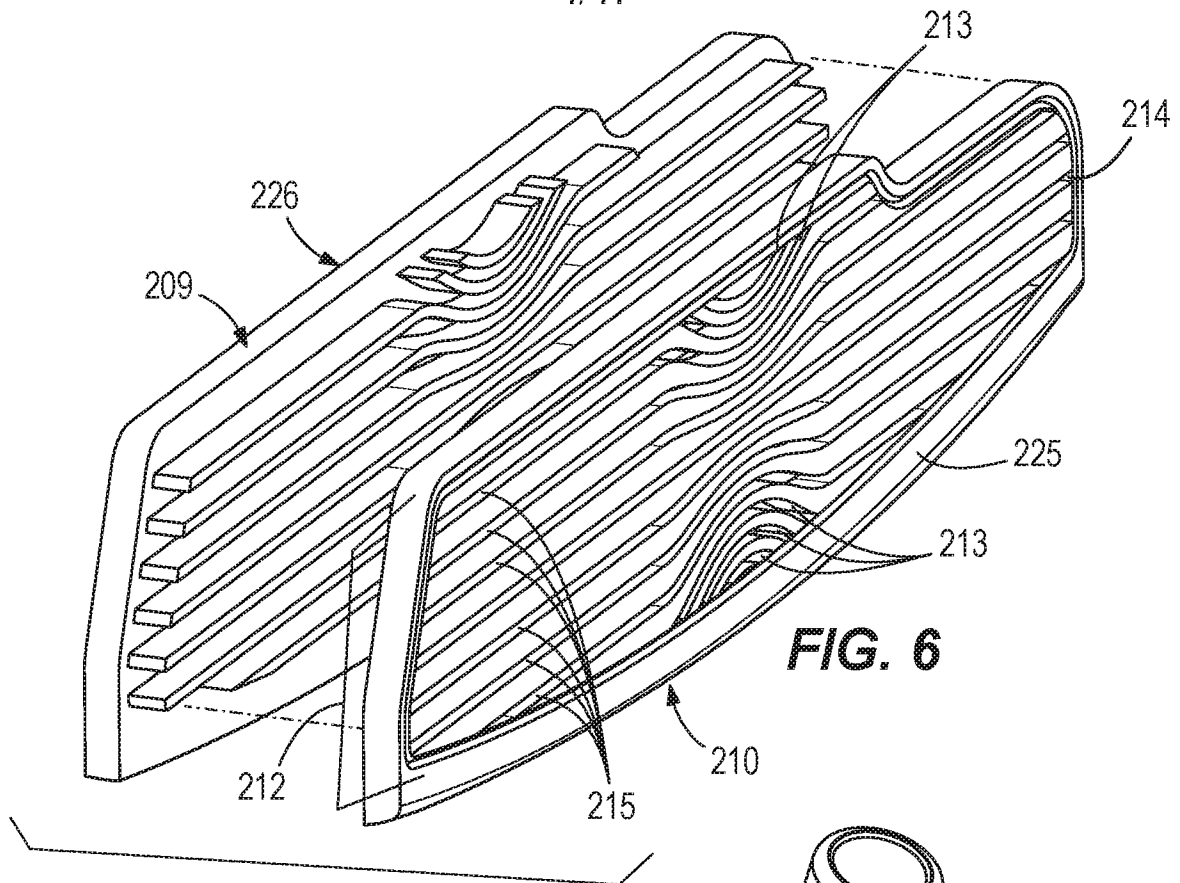

FIG. 6

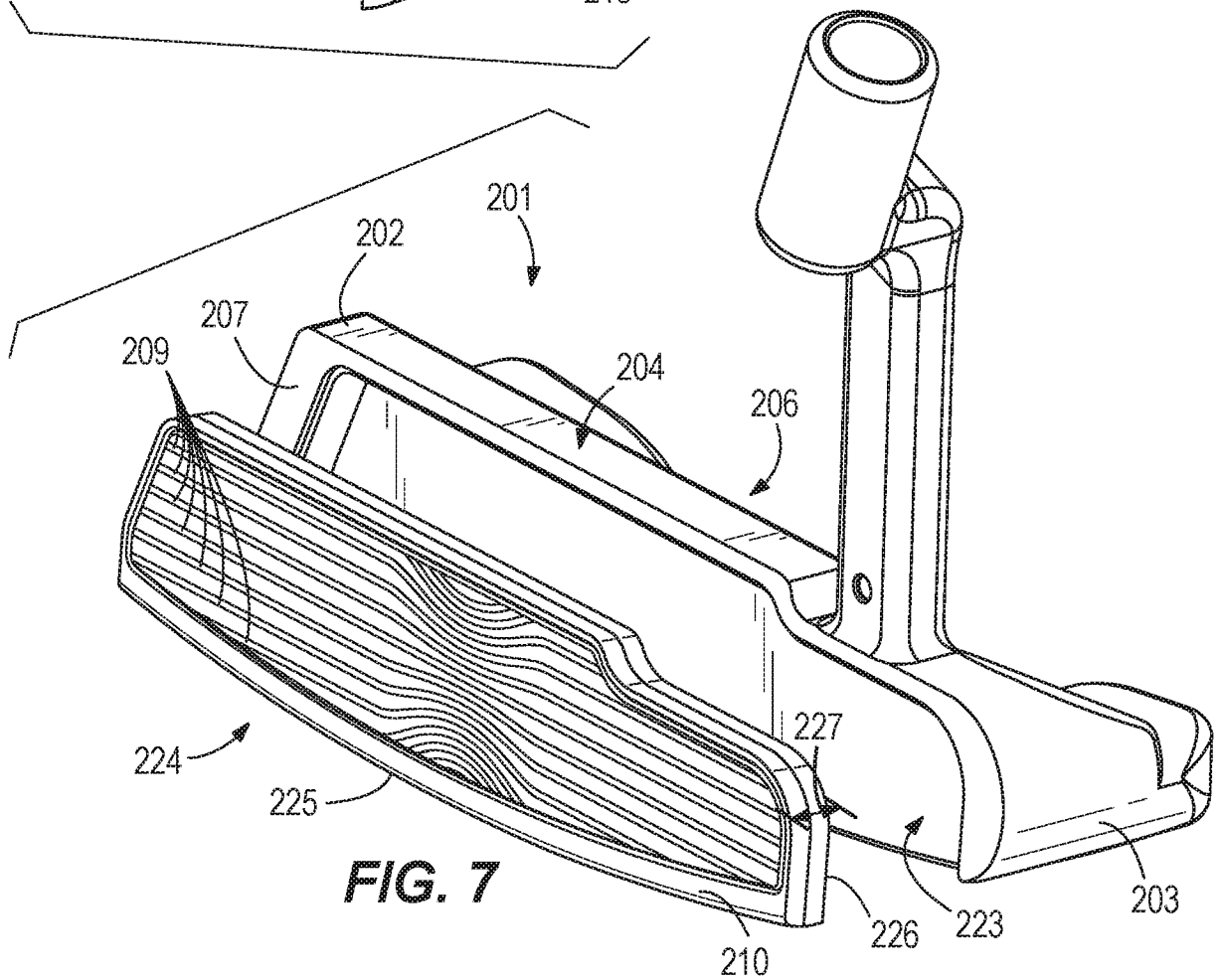

FIG. 7

5/17

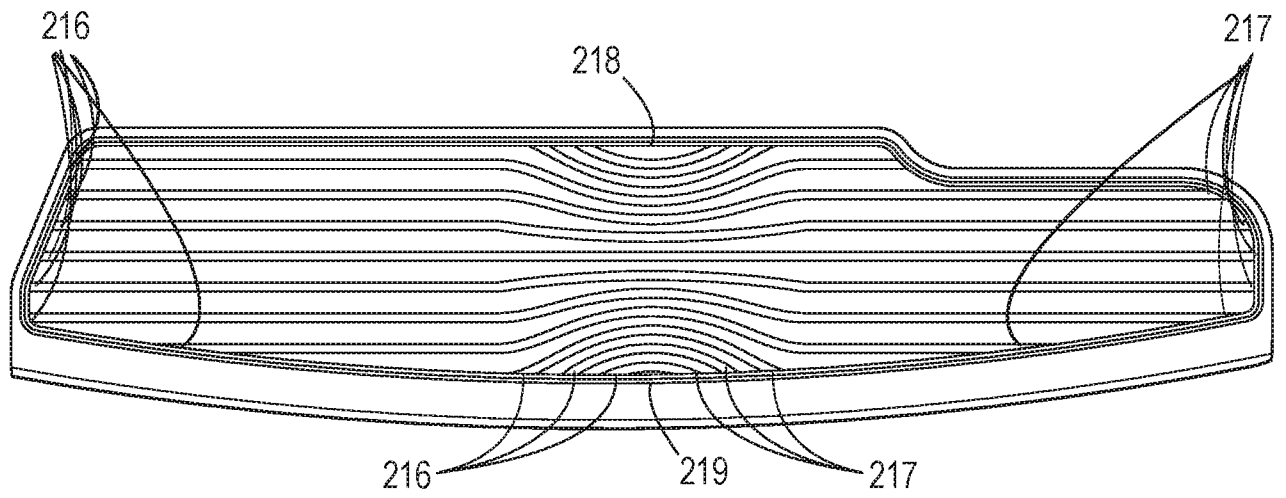

FIG. 8

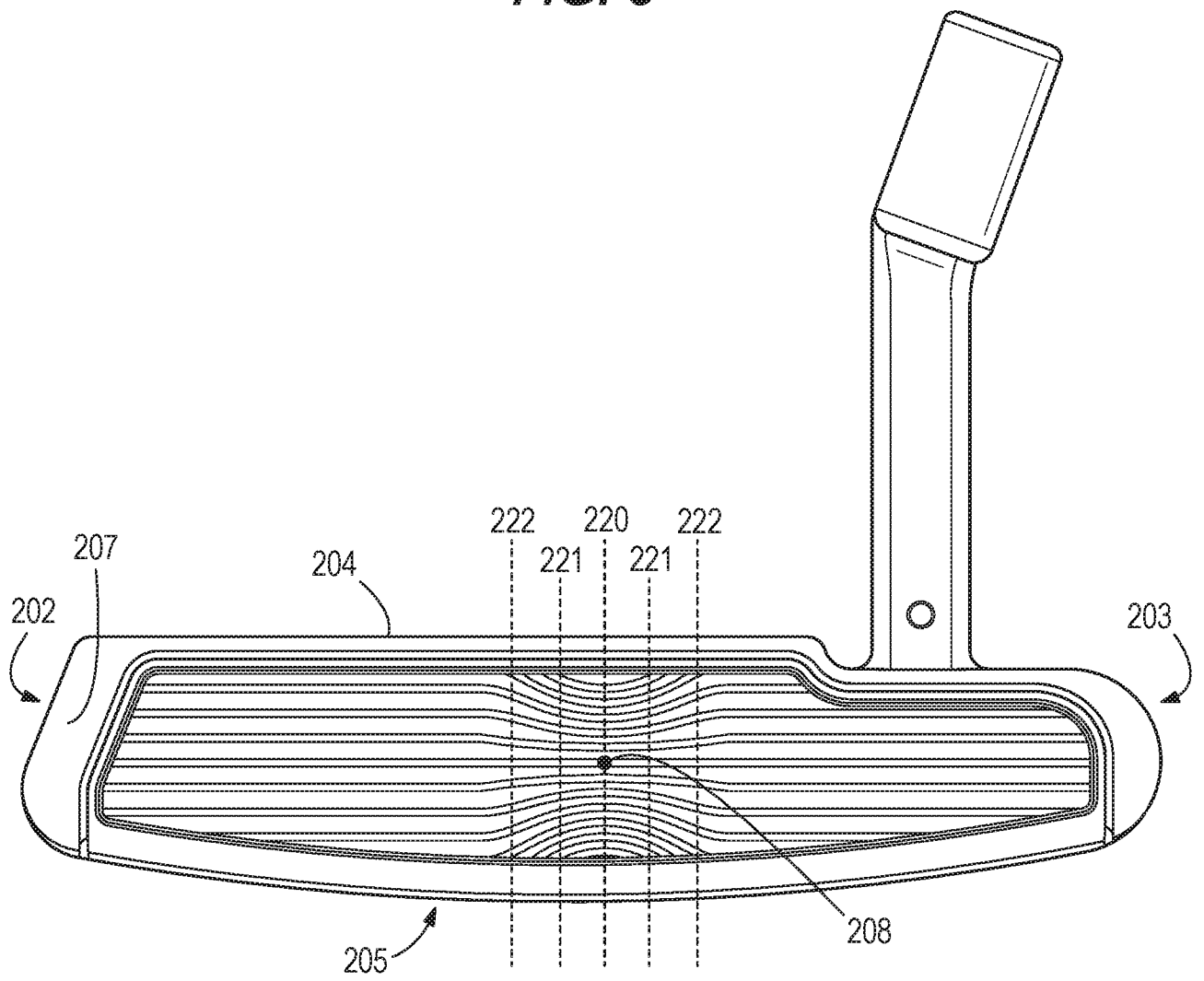

FIG. 9

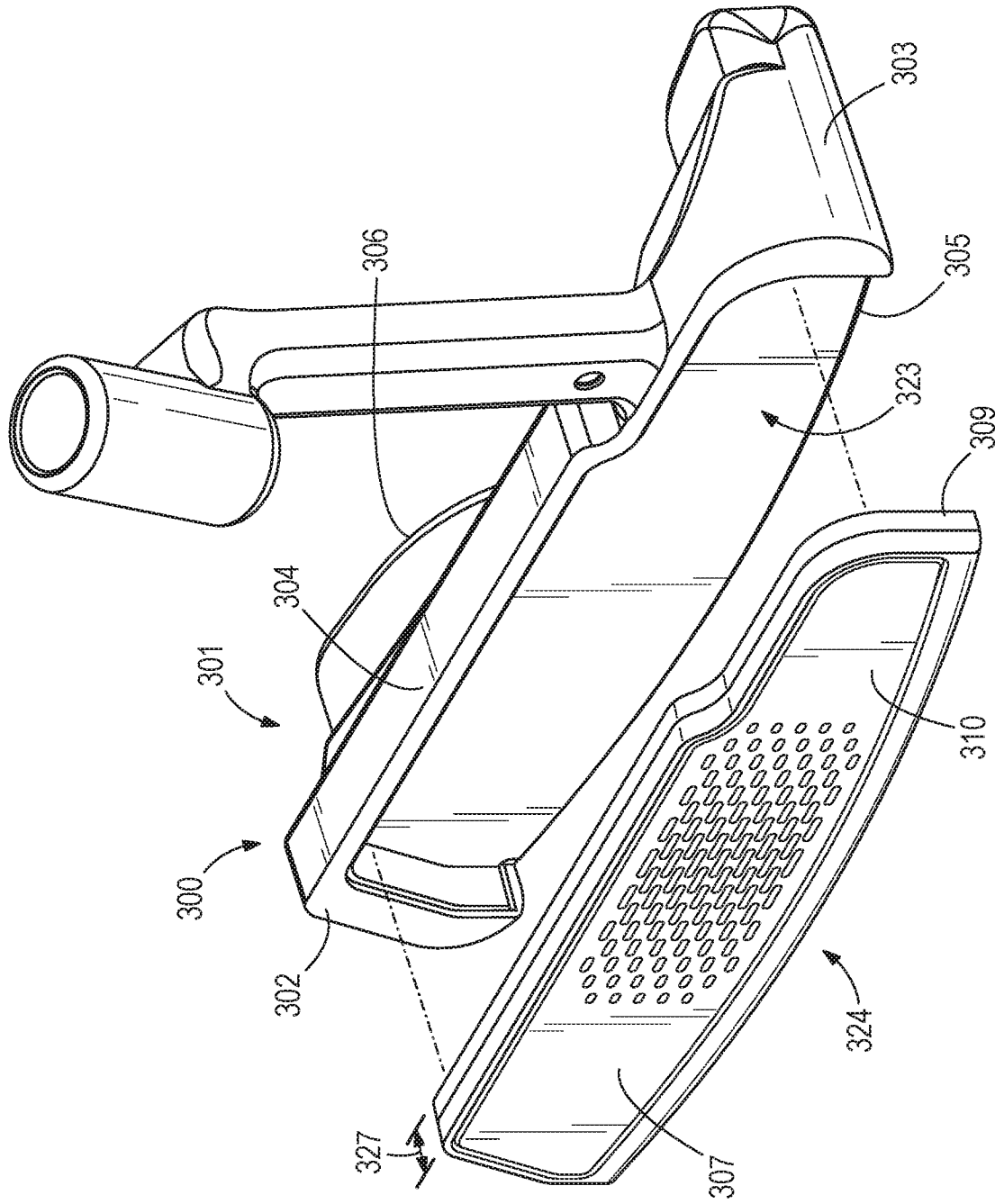

FIG. 10

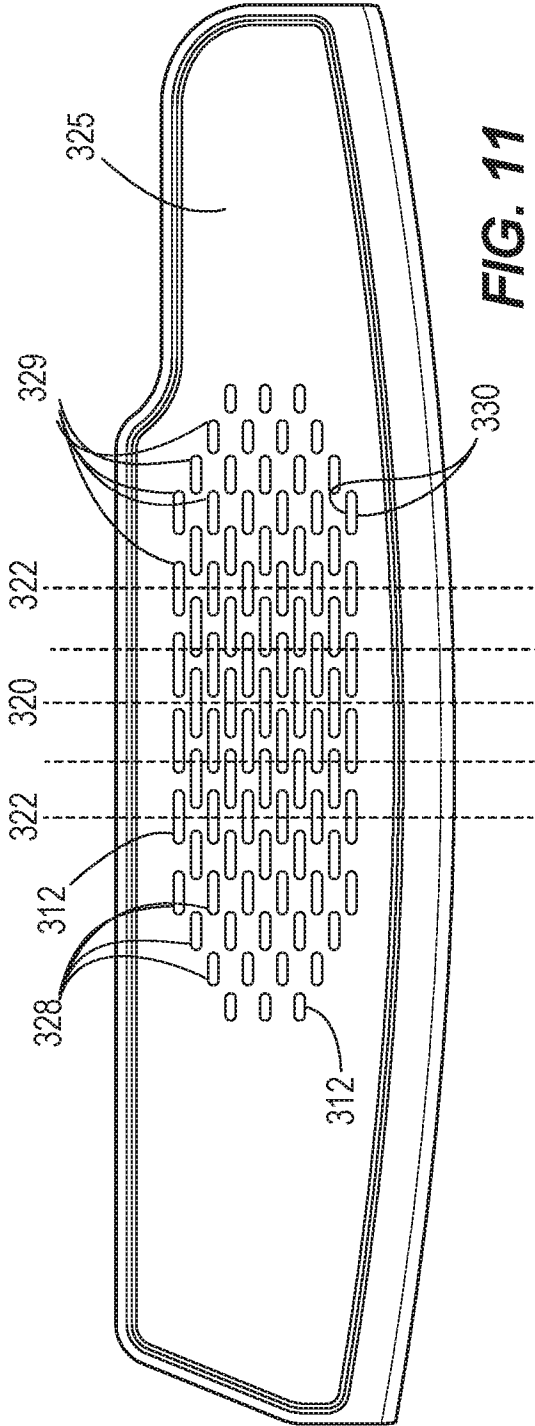

FIG. 11

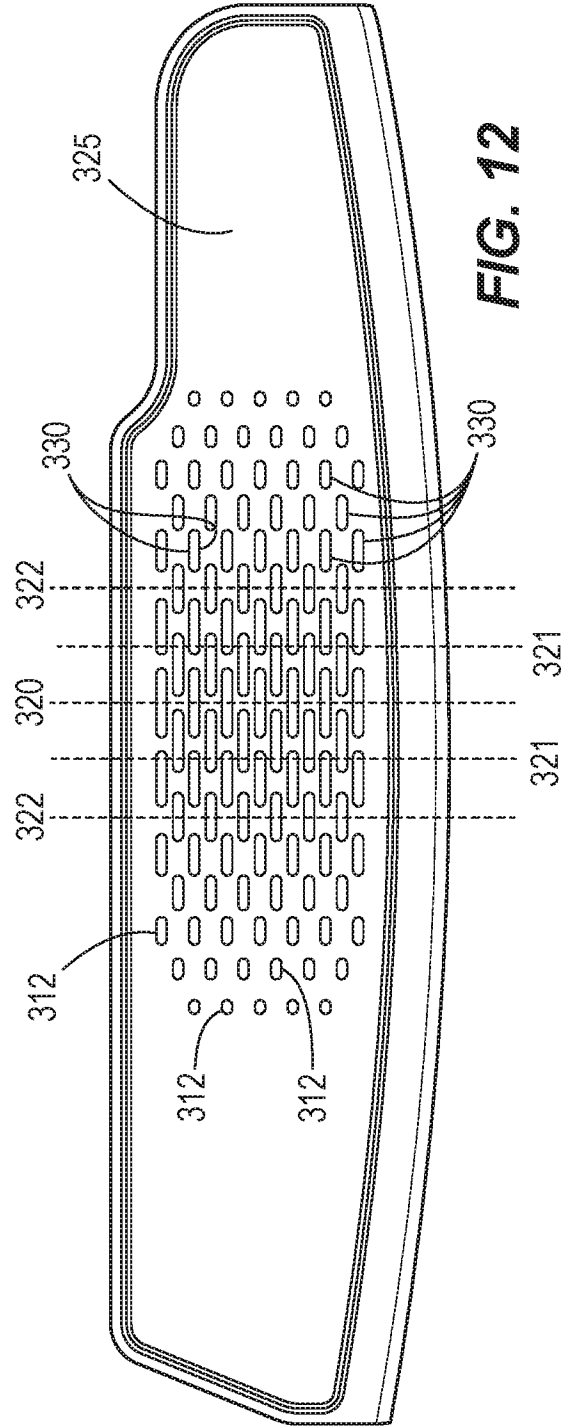

FIG. 12

8/17

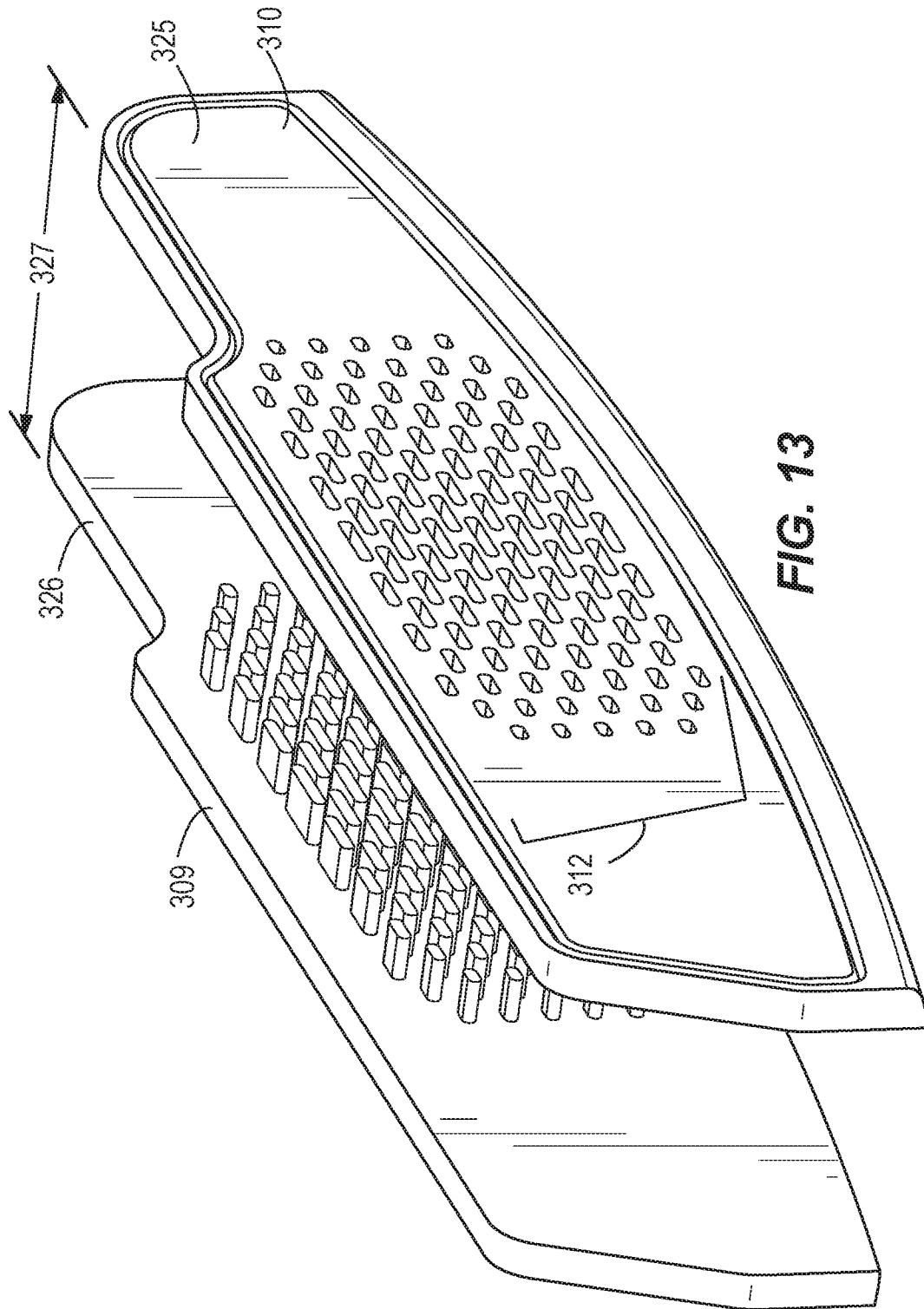

FIG. 13

9/17

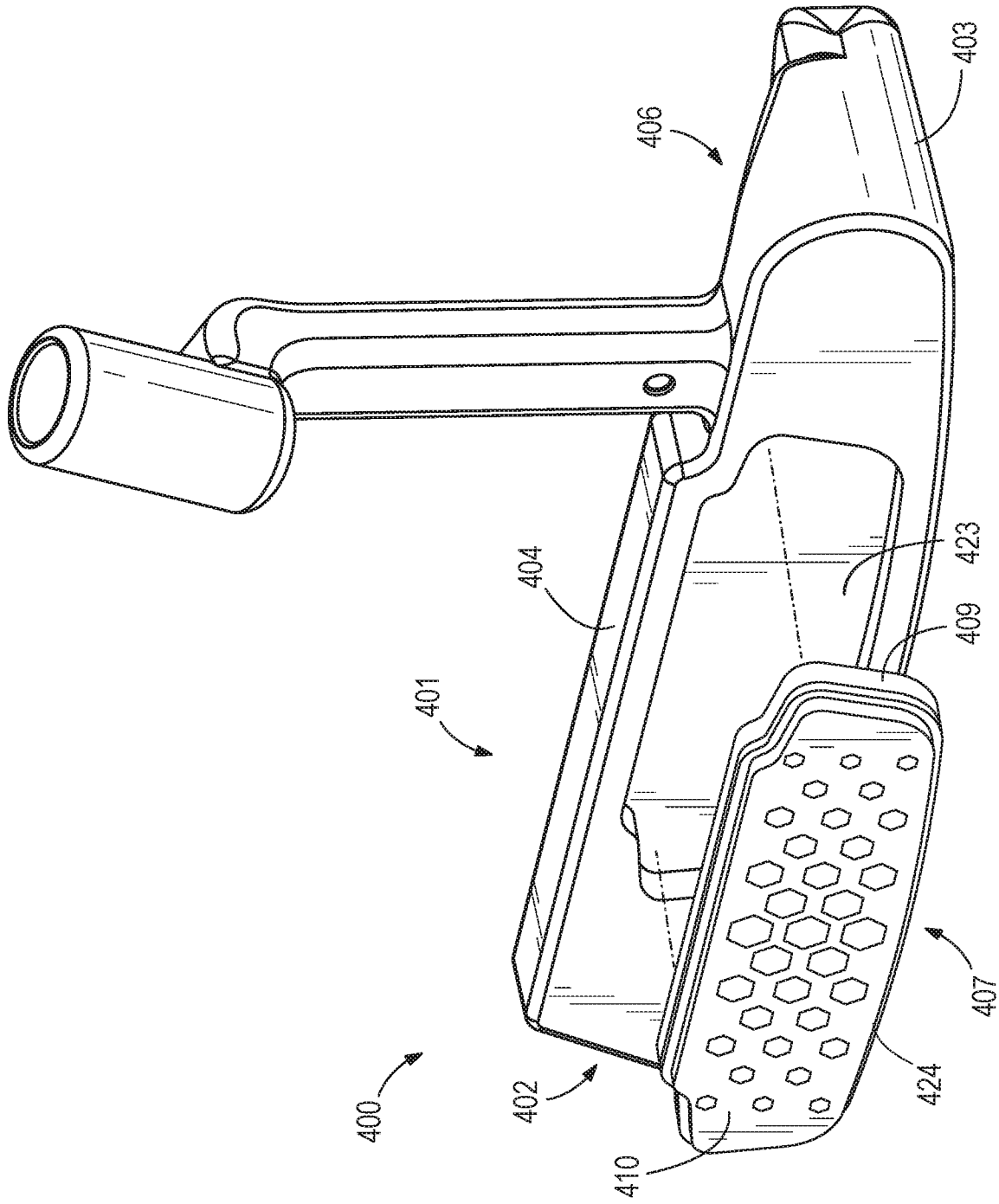
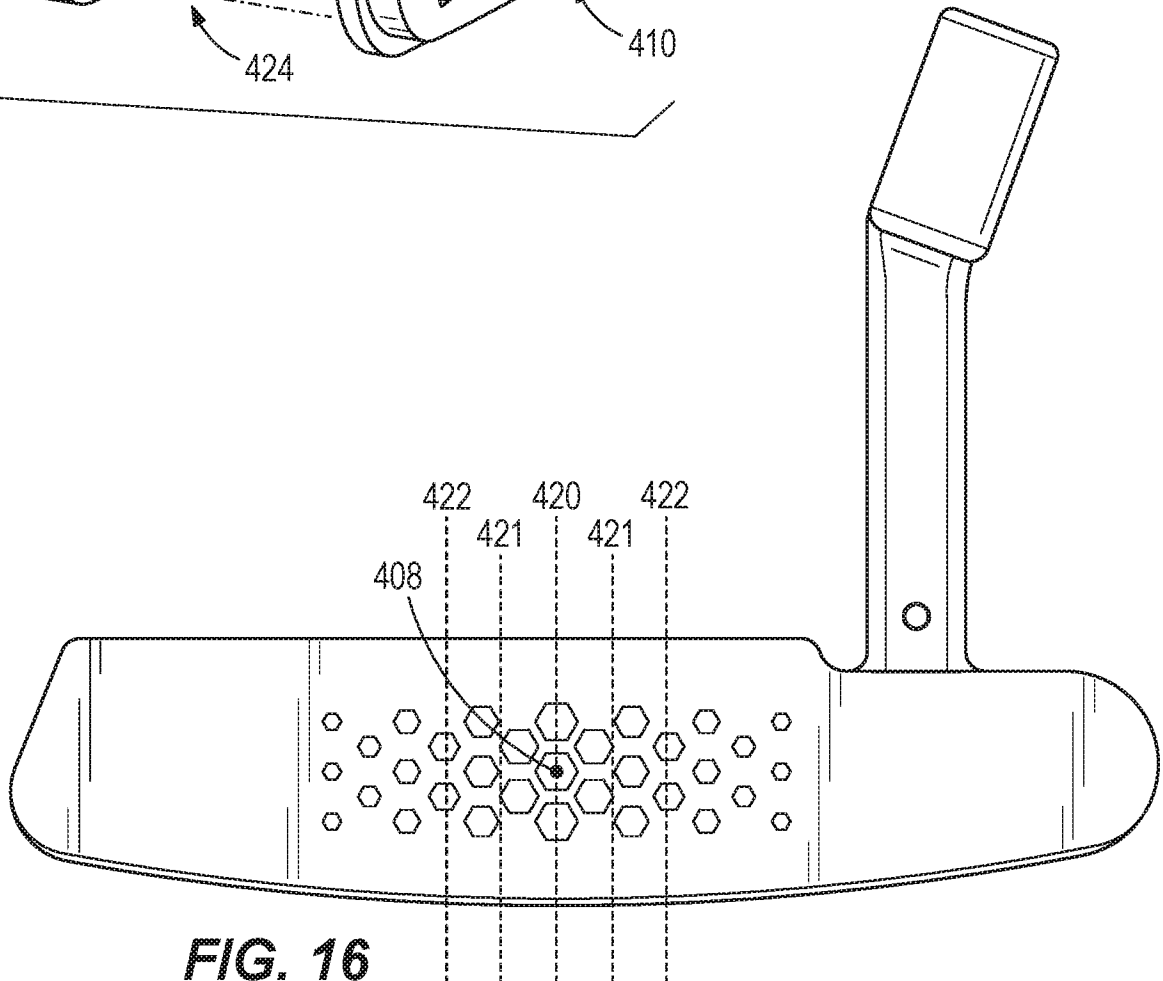
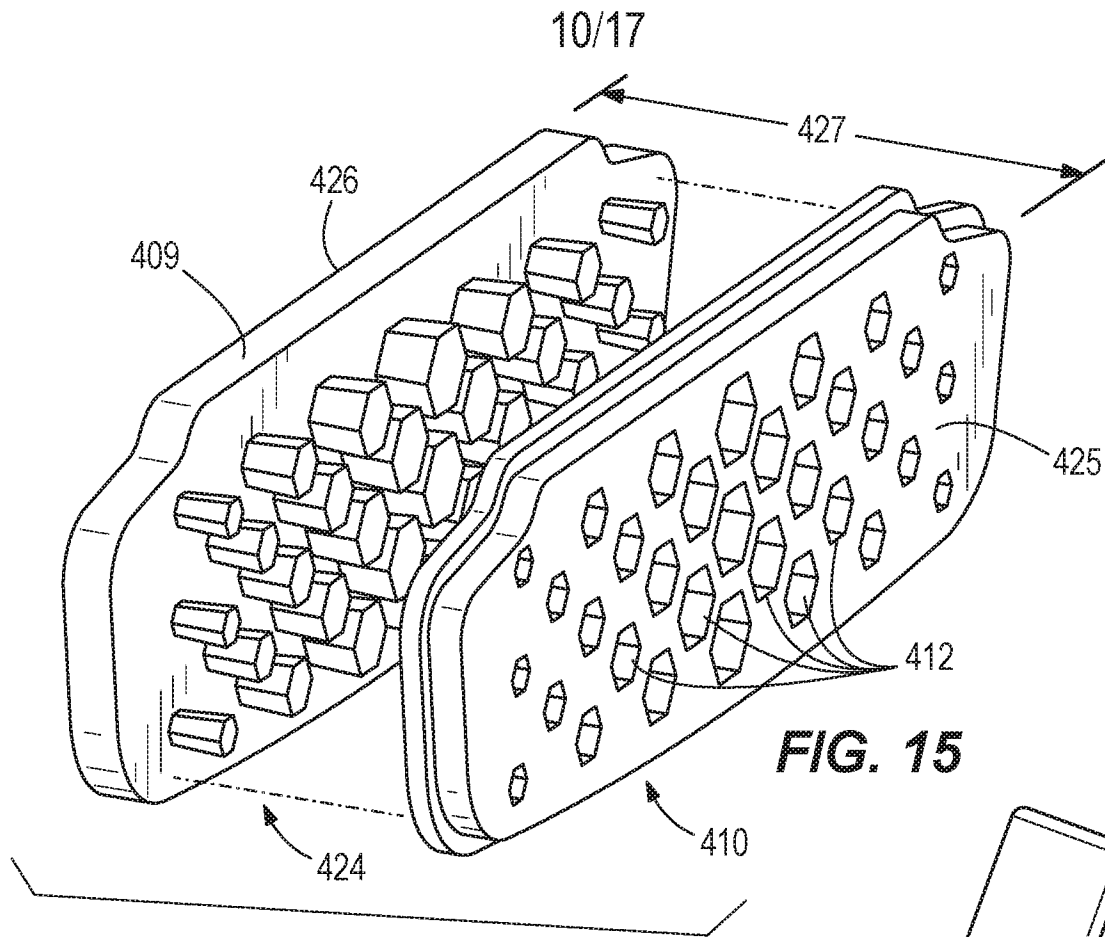
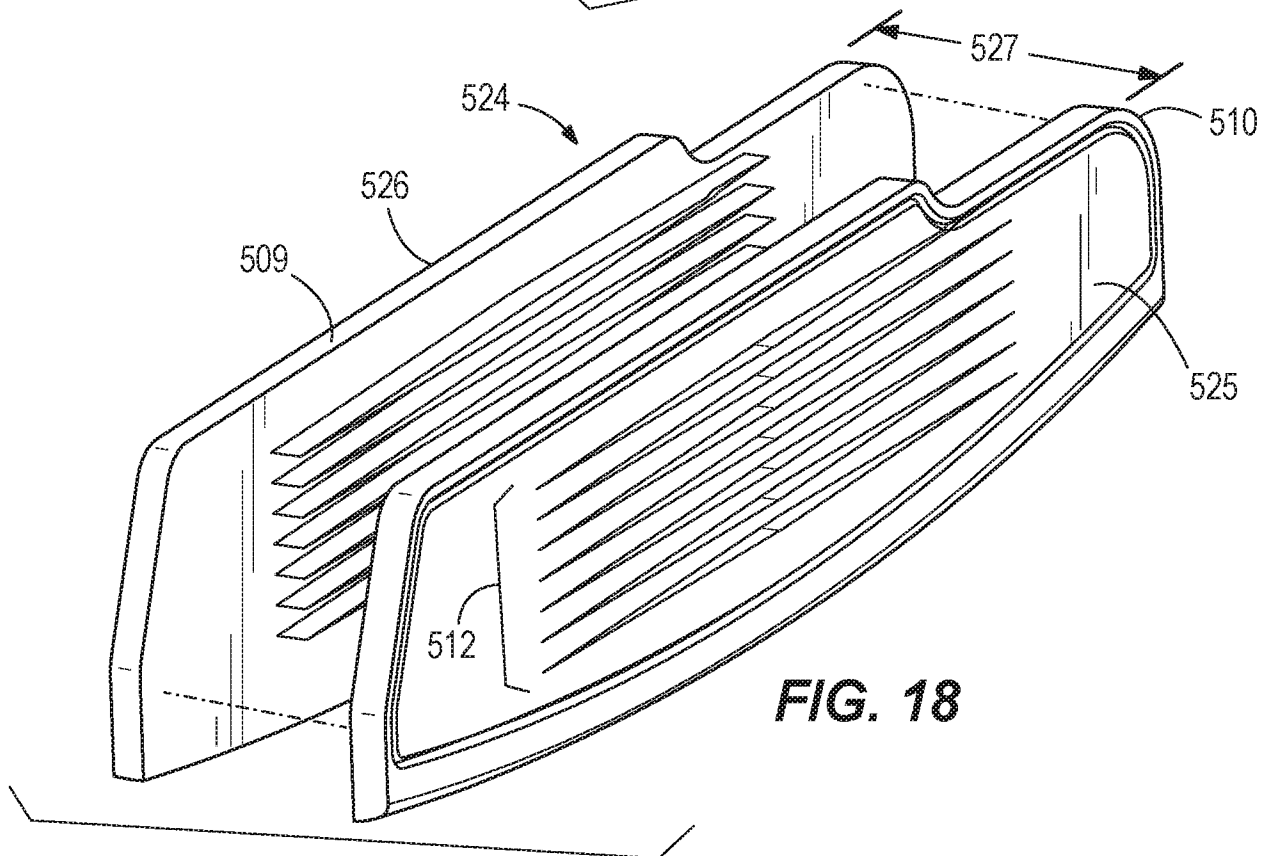
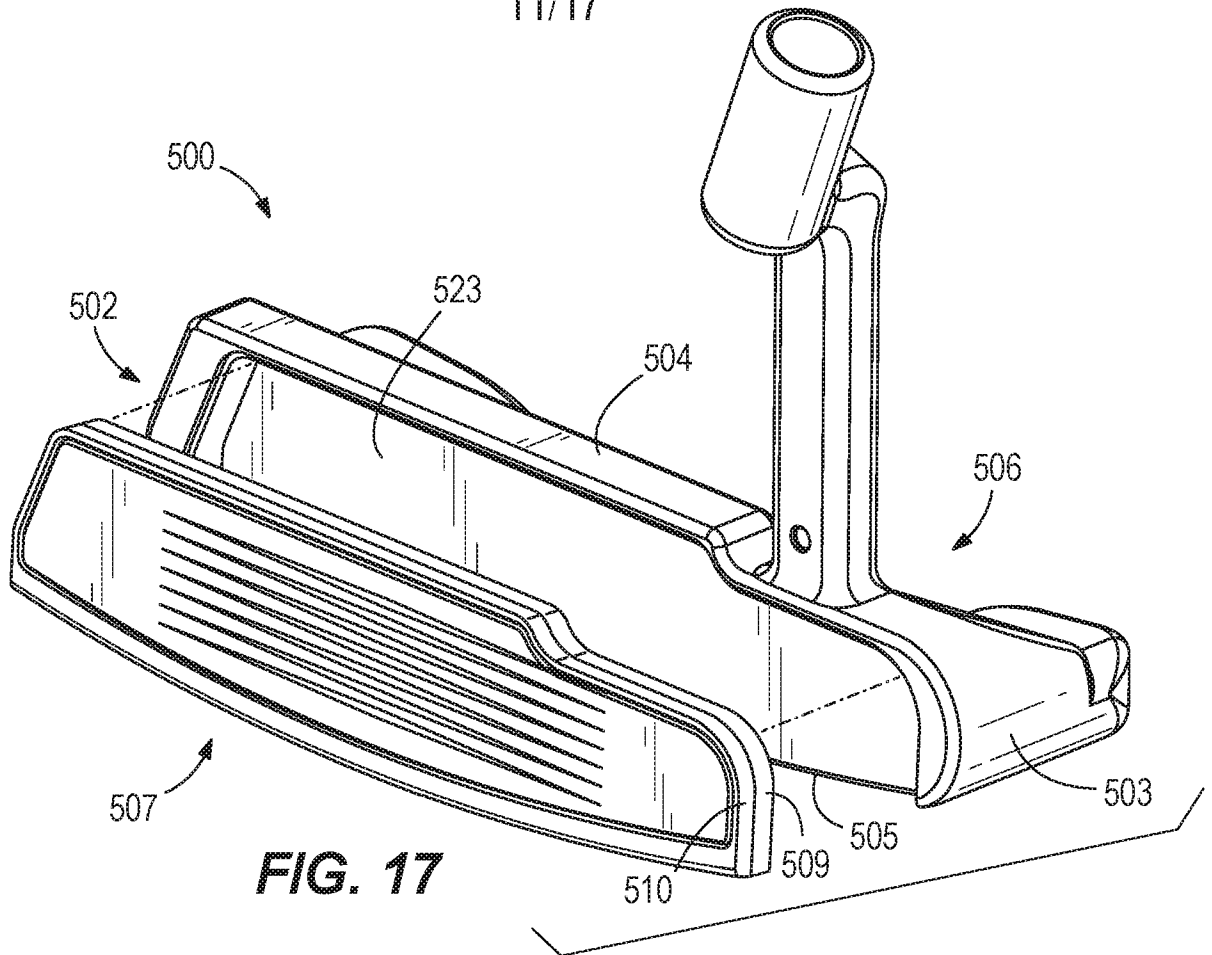

FIG. 14



11/17



12/17

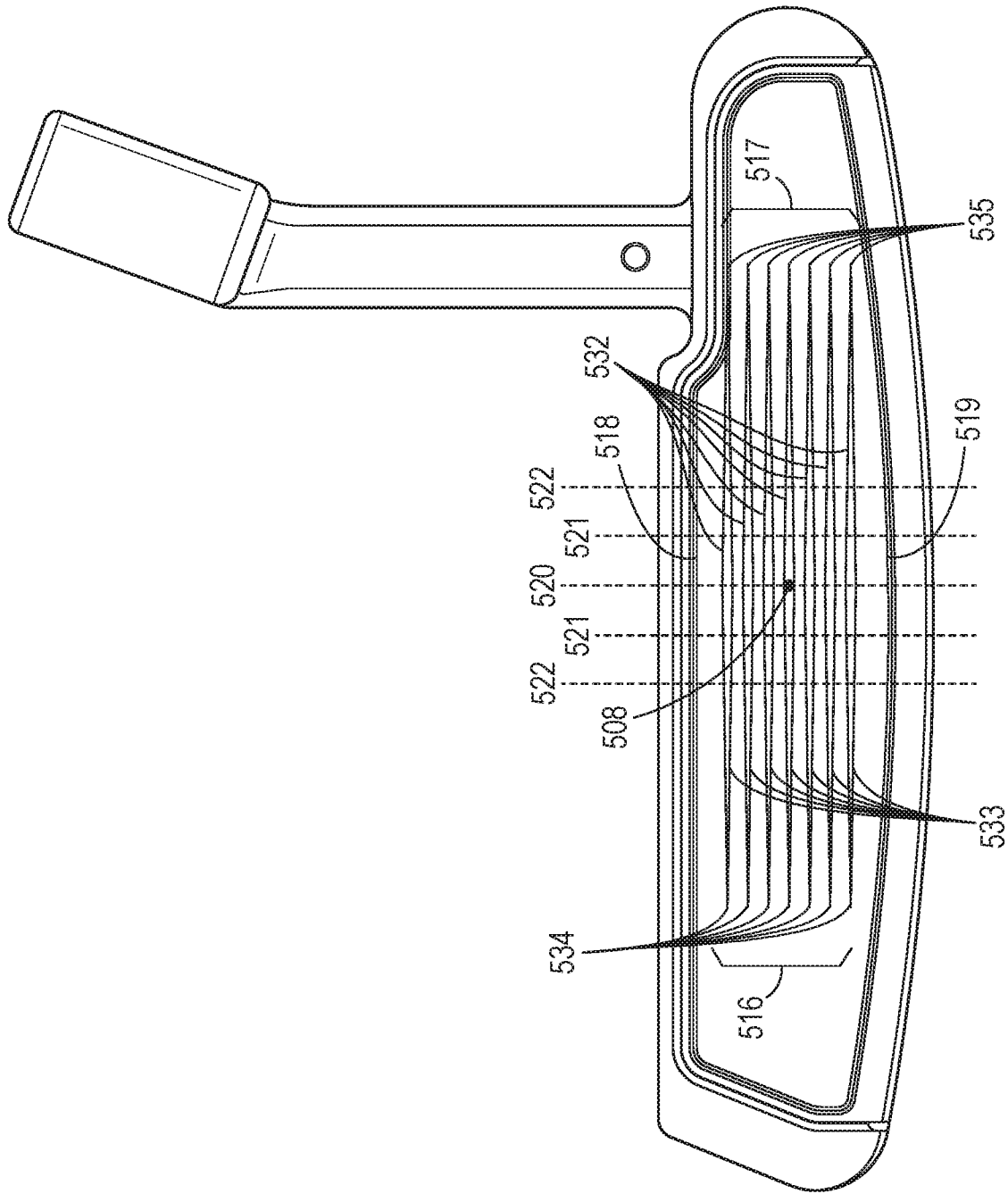

FIG. 19

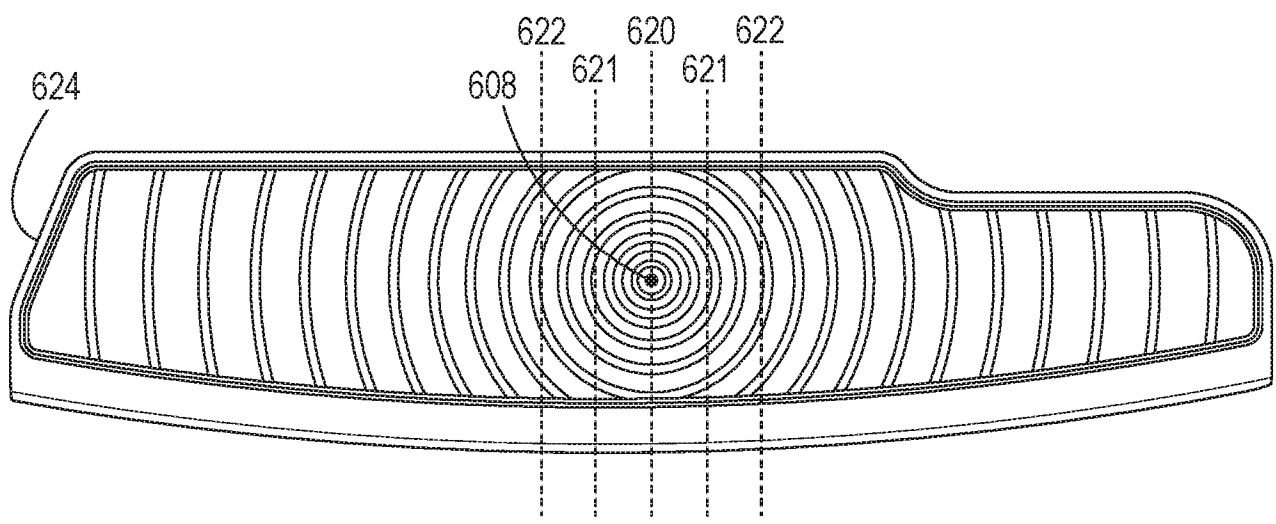
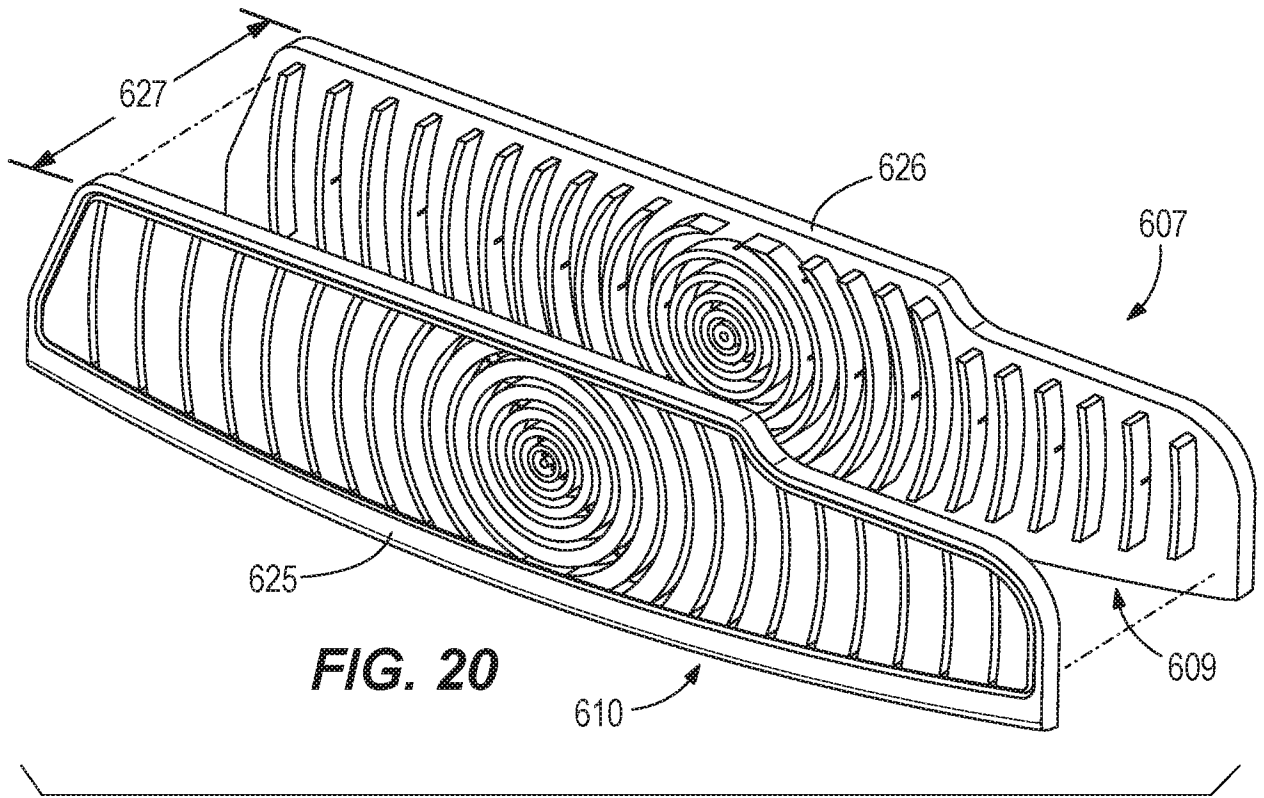

FIG. 21

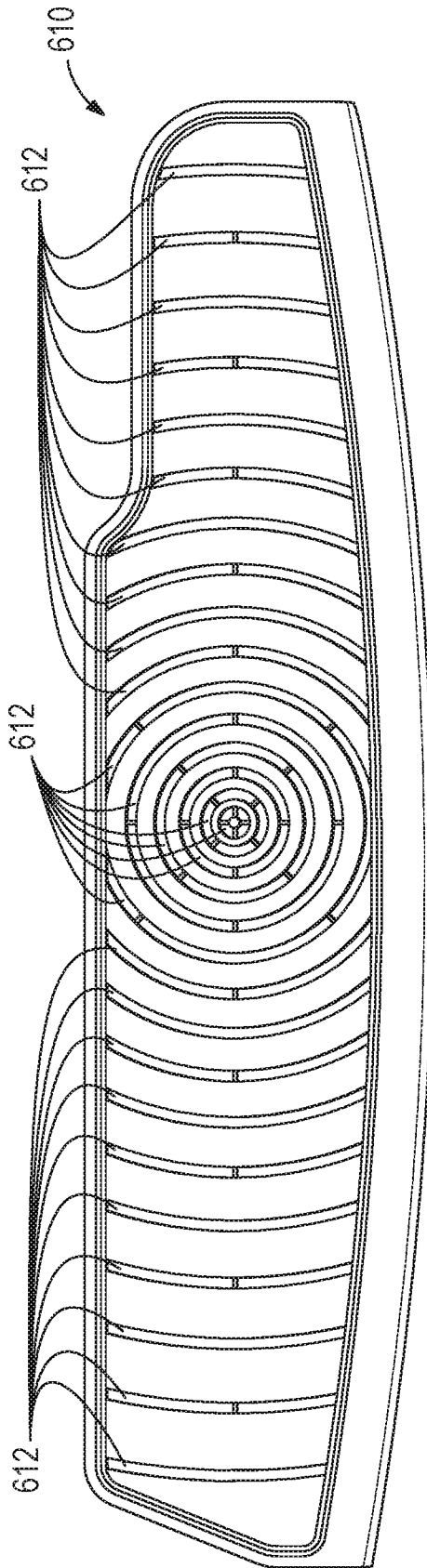

FIG. 22

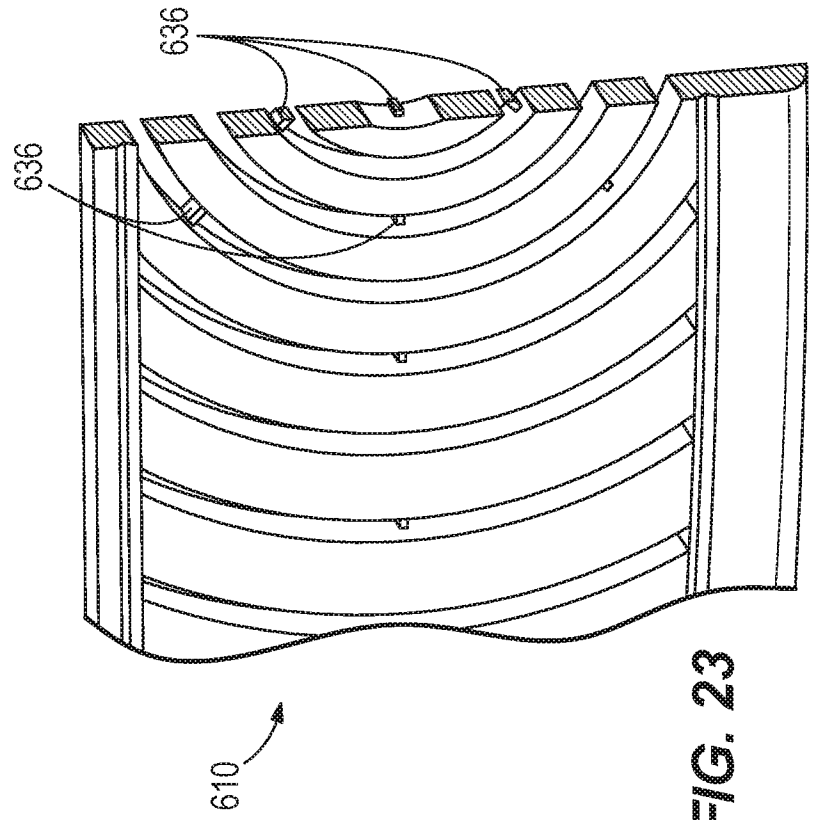

FIG. 23

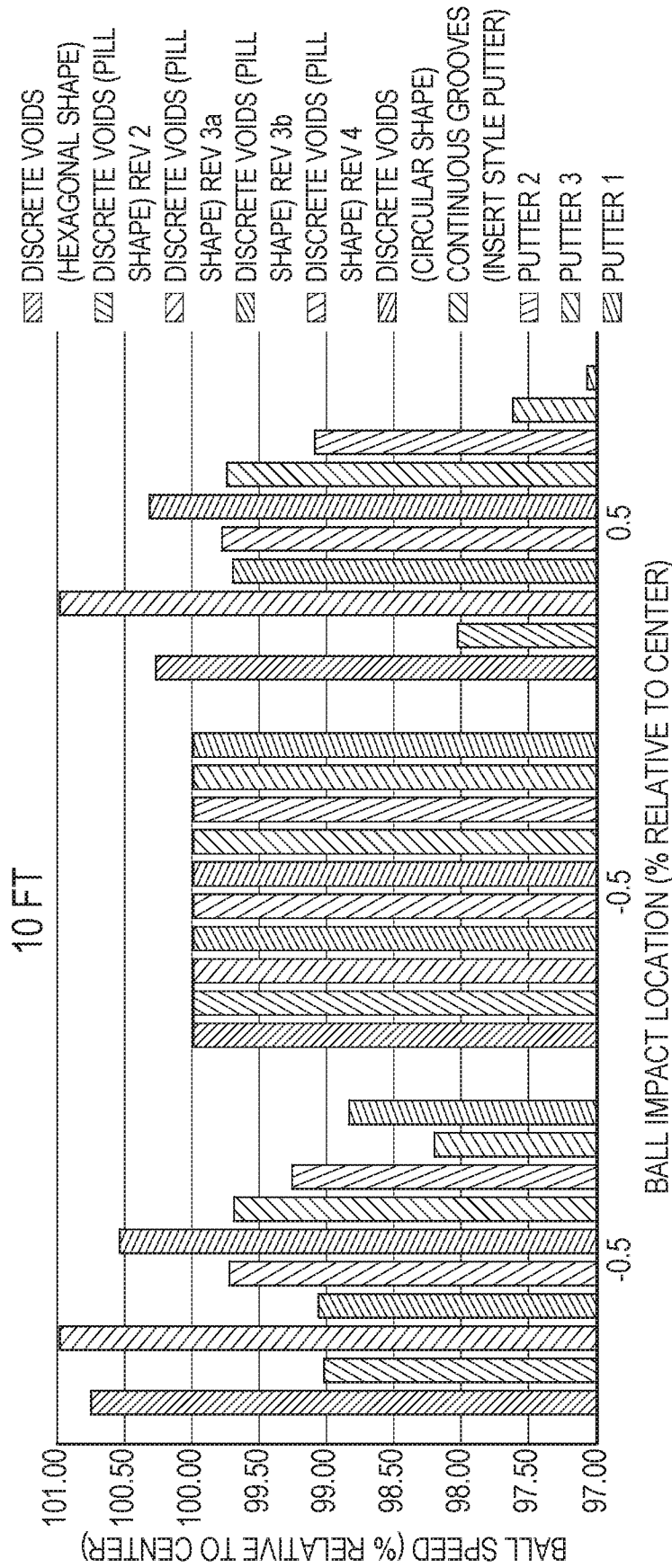

FIG. 24

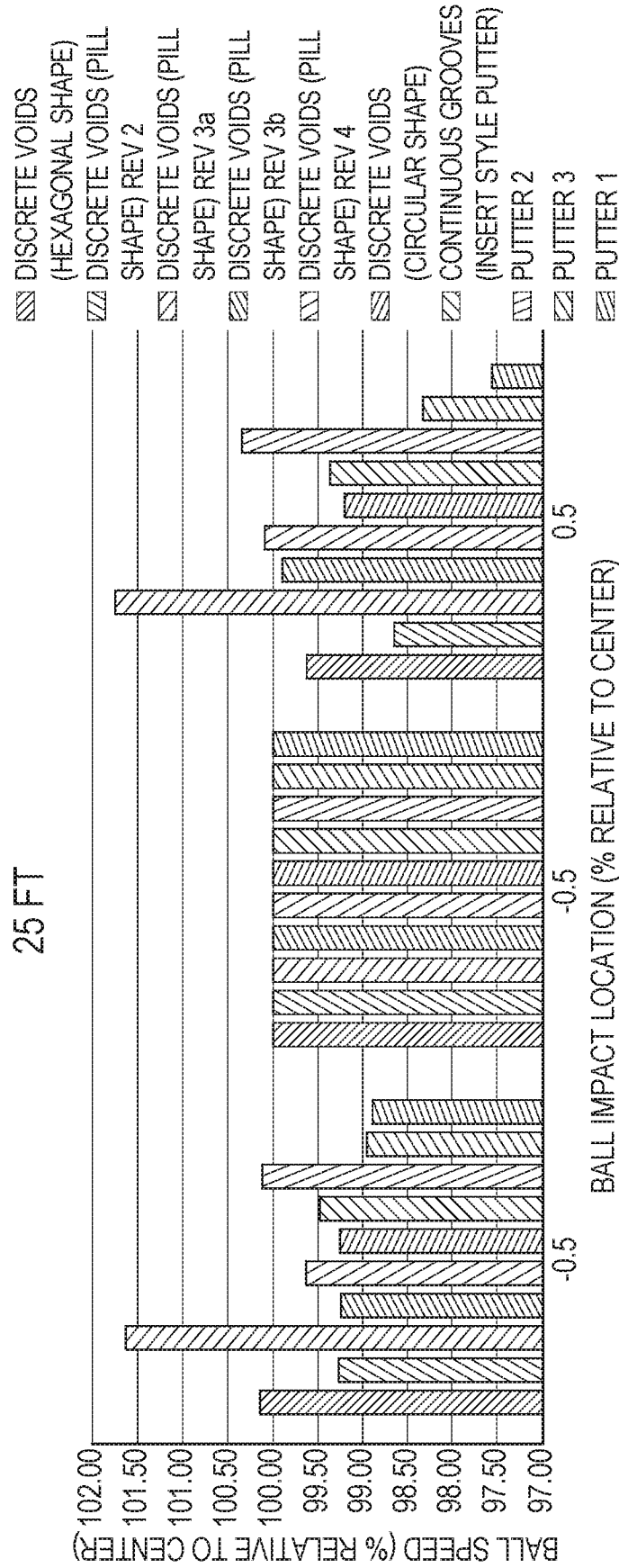

FIG. 25

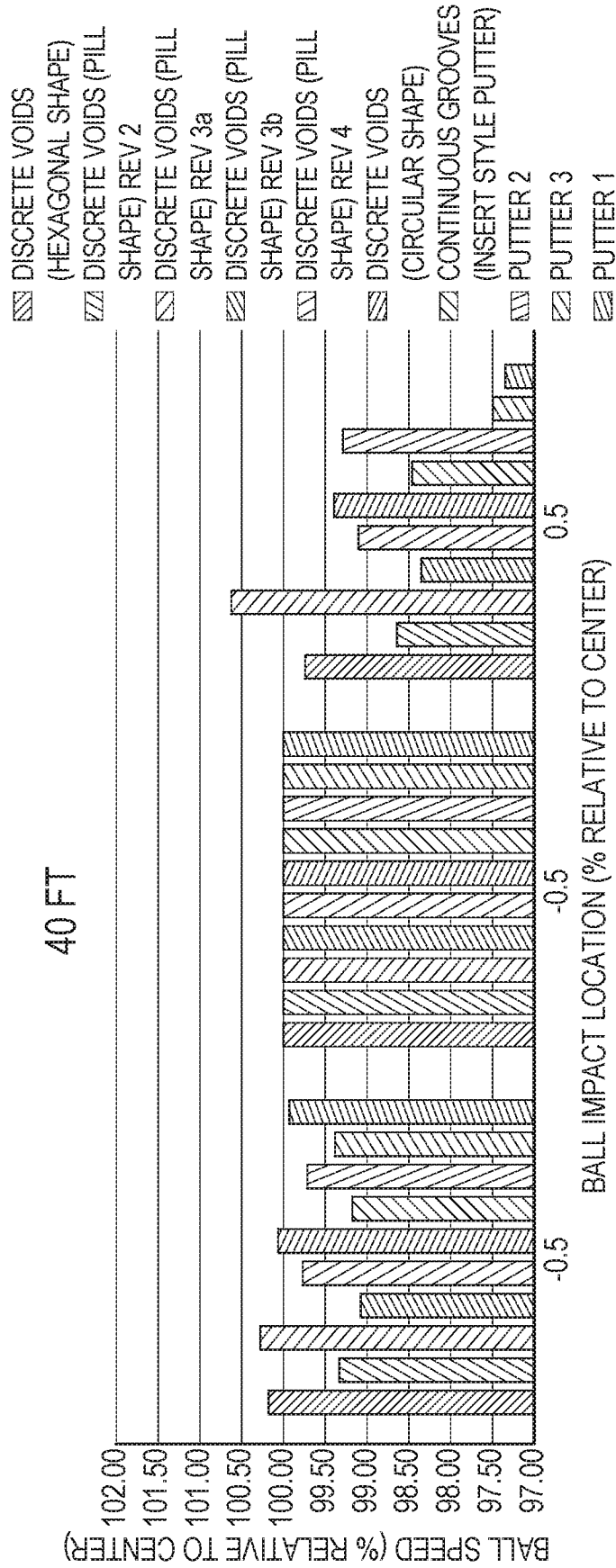

FIG. 26

INTERNATIONAL SEARCH REPORT

International application No.
PCT/US2020/044782

A. CLASSIFICATION OF SUBJECT MATTER
IPC(8) - A63B 53/04; A63B 53/00; A63B 60/00 (2020.01)
CPC - A63B 53/0425; A63B 53/007; A63B 53/0416; A63B 53/042; A63B 53/0445; A63B 53/0487; A63B 60/002 (2020.08)

According to International Patent Classification (IPC) or to both national classification and IPC

B. FIELDS SEARCHED

Minimum documentation searched (classification system followed by classification symbols)
see Search History document

Documentation searched other than minimum documentation to the extent that such documents are included in the fields searched
see Search History document

Electronic data base consulted during the international search (name of data base and, where practicable, search terms used)
see Search History document

C. DOCUMENTS CONSIDERED TO BE RELEVANT

Category*	Citation of document, with indication, where appropriate, of the relevant passages	Relevant to claim No.
A	US 2014/0045606 A1 (NIKE, INC.) 13 February 2014 (13.02.2014) entire document. See page 7 of the ISA/237.	1-20
A	US 2007/0149311 A1 (WRIGHT et al) 28 June 2007 (28.06.2007) entire document	1-20
A	US 2018/0085639 A1 (KARSTEN MANUFACTURING CORPORATION) 29 March 2018 (29.03.2018) entire document	1-20
A	US 6,257,994 B1 (ANTONIOUS) 10 July 2001 (10.07.2001) entire document	1-20
A	US 2005/0130757 A1 (TUCKER SR) 16 June 2005 (16.06.2005) entire document	1-20

Further documents are listed in the continuation of Box C. See patent family annex.

* Special categories of cited documents:

"A" document defining the general state of the art which is not considered to be of particular relevance	"T" later document published after the international filing date or priority date and not in conflict with the application but cited to understand the principle or theory underlying the invention
"D" document cited by the applicant in the international application	"X" document of particular relevance; the claimed invention cannot be considered novel or cannot be considered to involve an inventive step when the document is taken alone
"E" earlier application or patent but published on or after the international filing date	"Y" document of particular relevance; the claimed invention cannot be considered to involve an inventive step when the document is combined with one or more other such documents, such combination being obvious to a person skilled in the art
"L" document which may throw doubts on priority claim(s) or which is cited to establish the publication date of another citation or other special reason (as specified)	"&" document member of the same patent family
"O" document referring to an oral disclosure, use, exhibition or other means	
"P" document published prior to the international filing date but later than the priority date claimed	

Date of the actual completion of the international search 01 October 2020	Date of mailing of the international search report 16 OCT 2020
Name and mailing address of the ISA/US Mail Stop PCT, Attn: ISA/US, Commissioner for Patents P.O. Box 1450, Alexandria, VA 22313-1450 Facsimile No. 571-273-8300	Authorized officer Blaine R. Copenheaver Telephone No. PCT Helpdesk: 571-272-4300