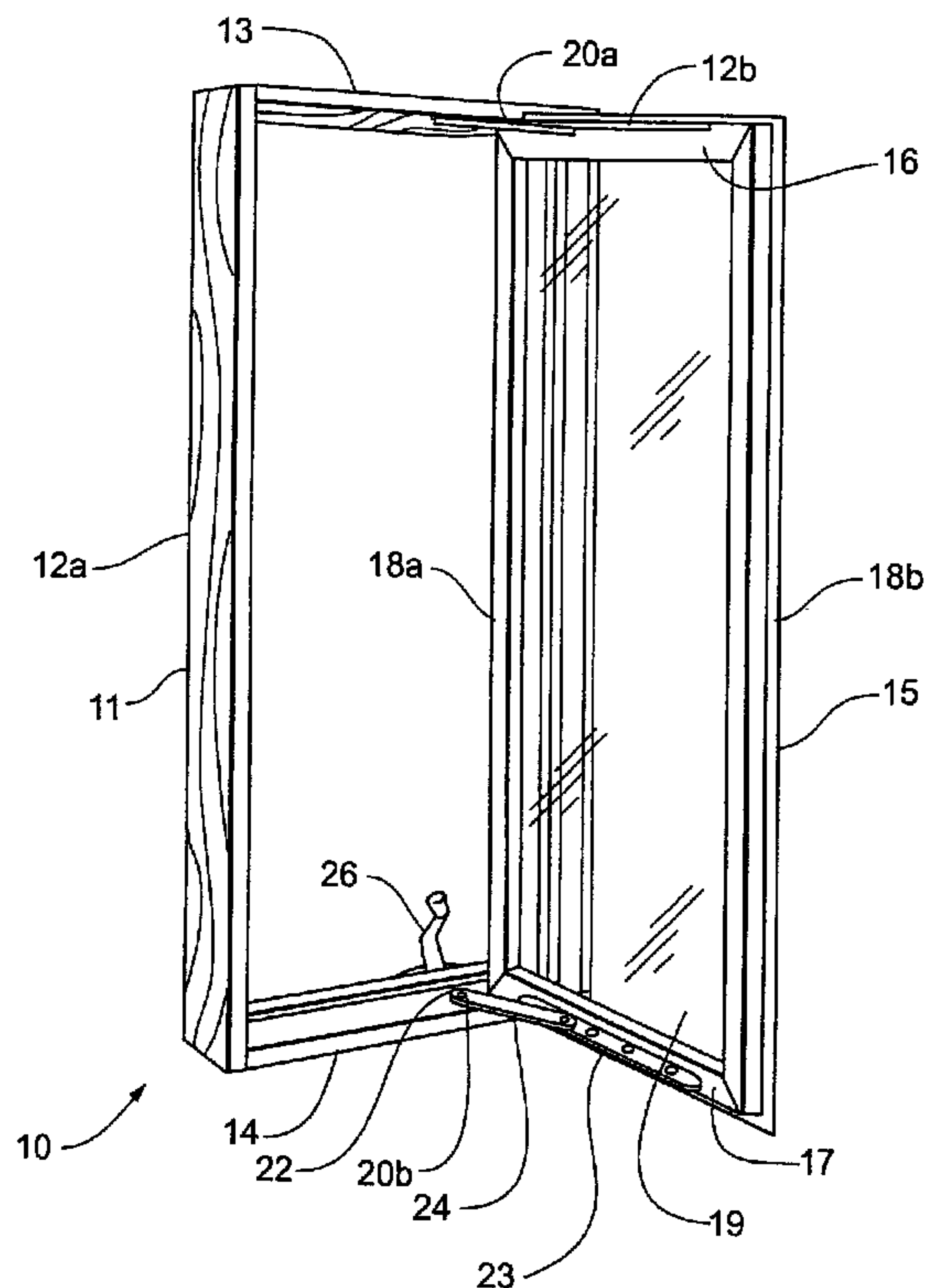




(22) Date de dépôt/Filing Date: 2006/10/27  
(41) Mise à la disp. pub./Open to Public Insp.: 2007/05/07  
(30) Priorité/Priority: 2005/11/07 (US11/268,759)

(51) Cl.Int./Int.Cl. *E05D 15/30* (2006.01)  
(71) Demandeur/Applicant:  
TRUTH HARDWARE CORPORATION, US  
(72) Inventeurs/Inventors:  
BRUZEK, DAN, US;  
TITUS, JOHN E., US;  
FRENZEN, TIM, US;  
VELZKE, CLARK, US  
(74) Agent: MOFFAT & CO.

(54) Titre : ASSEMBLAGE A CHARNIERE POUR FENETRES A BATTANTS  
(54) Title: HINGE ASSEMBLY FOR CASEMENT WINDOWS



(57) **Abrégé/Abstract:**

An improved hinge assembly for a casement window including a track having a cam engaging portion defining a non-circular aperture, a sash arm pivotably and slidably coupled to the track, and a support arm pivotably coupled to the track on a first end and to the to the sash arm at the opposing end. The improved hinge further includes an adjustable cam operably connected through the support arm to engage the non-circular aperture within the track such that rotation of the adjustable cam selectively shifts the position of the support arm relative to the track to alleviate sash sag.

ABSTRACT OF THE INVENTION

An improved hinge assembly for a casement window including a track having a cam engaging portion defining a non-circular aperture, a sash arm pivotably and slidably coupled to the track, and a support arm pivotably coupled to the track on a first end and to  
5 the to the sash arm at the opposing end. The improved hinge further includes an adjustable cam operably connected through the support arm to engage the non-circular aperture within the track such that rotation of the adjustable cam selectively shifts the position of the support arm relative to the track to alleviate sash sag.

## HINGE ASSEMBLY FOR CASEMENT WINDOWS

### Field of the Invention

The invention relates to an improved casement window, and in particular to a  
5 casement window hinge assembly having structure to reduce sash sag.

### Background of the Invention

Casement windows assemblies are well known in the art and described in, for  
example, U.S. Patent No. 3,845,585 to Cecil, entitled "Casement Window," and U.S.  
10 Patent 4,254,583 to Smits et al., entitled "Window Unit," which are both hereby  
incorporated by reference herein. In general, a casement window includes a window sash  
comprised of a sheet of glass surrounded by wood, vinyl or metal structure. A casement  
window has the sash hinged to one side in comparison to windows where the sash slides  
within the frame. The window sash engages the window frame through an upper and  
15 lower hinge assembly. The casement window sash rotates within the window frame  
along a vertical axis. Typically a crank mechanism is attached to the lower hinge for  
selectively opening and closing the window sash. Proper performance of the casement  
window requires that the window sash be properly aligned within the window frame.

One of the more common issues regarding casement windows is sash sag, which  
20 occurs when the sash portion of the window is out of square with the window frame.  
Sash sag can result from movement during installation, improper hinge positioning by the  
window manufacturer, settling of the building, warpage of the window or from external  
contact with the window sash in the open position. A window with sash sag will not  
properly seal. As a result the window is less effective in preventing moisture from

coming in to the structure as well as increasing energy costs for heating and cooling of the building. Moreover, the improper seal may allow moisture into the window frame itself, which can lead to rotting of the window frame and the structure.

Correction of sash sag requires realigning the hinge so that the sash sits properly  
5 within the window frame. On some windows this requires disassembly of the hinge, which is labor intensive and costly. In the alternative, sash sag may be corrected with an adjustable hinge mechanism. An example of an adjustable mechanism designed to alleviate sash sag is disclosed in U.S. Patent Re. 34,657 ('657 reissue) to La See, entitled  
10 "Cam Adjustment Device For Casement Window Unit," which is hereby incorporated by reference herein. More specifically, the '657 reissue discloses an index cam comprising a series of serrations that can engage a plurality of serrations on the track of the hinge assembly, which permits the cam to move relative to the track and facilitates adjustment of a link connected to a casement window sash. However, the engagement of the serrations on the cam with corresponding serrations on the track only permits  
15 predetermined, or defined, movements of the cam within the track. Additionally, the detailed structure of the cam and the track can increase manufacturing costs and make it make difficult to adjust the window sash once the hinge assembly has been installed.

With the number of residential casement windows being installed in new and existing homes, it would be desirable to provide a hinge assembly that can reduce or  
20 eliminate sash sag and overcome the limitations mentioned above. What is still needed is an adjustable hinge assembly that can be easily adjusted without disassembly of the casement window to reduce and/or eliminate sash sag, and that can be manufactured at a lower cost relative to existing hinge assemblies.

Summary of the Invention

The hinge assembly of the present invention addresses the above-mentioned needs by providing a mechanism that can be adjusted to reduce and/or eliminate sash sag without requiring disassembly of the casement window assembly. Additionally, the  
5 hinge assemblies of the present disclosure do not comprise locking structures and therefore can be manufactured at lower costs relative to existing hinges.

In a first embodiment, the improved hinge assembly includes a track having an upwardly struck cam engaging portion defining a non-circular aperture, a first elongated arm or sash arm pivotably coupled to the track assembly, and a second elongated arm or  
10 support arm pivotably coupled to the track assembly and to the first elongated arm. The improved hinge further includes a cam member operably connected to the second elongated arm and the track. The cam member has an aperture engaging portion adapted to engage the non-circular aperture of the track such that the aperture engaging portion is  
15 selectively shiftable within the non-circular aperture. Shifting the aperture engaging portion within the non-circular aperture facilitates adjustment of the second elongated arm, and the attached window sash, which can reduce and/or eliminate sash sag. The non-circular aperture can be a tri-lobed opening, while the aperture engaging portion can  
20 comprise an oval shape, an elliptical shape or the like. In embodiments where the aperture engaging portion is an oval shaped stud, the oval engaging portion can allow the cam member to be shifted up to about thirty-five degrees longitudinally in either direction from a center position within the tri-lobed aperture.

Due to the structure of the non-circular aperture and the aperture engaging portion, the second elongated arm and the attached window sash can be adjusted relative

to the track such that sash sag can be reduced and/or eliminated. In some embodiments, the aperture engaging portion can move within the non-circular aperture such that the movement of the aperture engaging portion is not limited or inhibited by protrusions, serrations or the like, which facilitates finer adjustment of the second elongated arm.

5 Moreover, since the aperture engaging portion and the non-circular aperture do not comprise locking structures such as protrusions or serrations, the hinges of the present disclosure can be manufactured at a lower cost than hinges having locking structures and the like. The structure of the aperture engaging portion, along with the non-circular aperture, can also facilitate adjustment of the second elongated arm, and the attached  
10 window sash, without disassembling the sash from the hinge assembly.

In a first aspect, the invention pertains to a hinge for use with casement window assemblies having a track with a cam engaging portion defining a tri-lobed aperture, a first elongated arm pivotably coupled to the track, and a second elongated arm pivotably coupled to the track and to the first elongated arm. In these embodiments, the hinge can  
15 further include a cam member operably connected to the second elongated arm, the cam member having an oval engaging portion positioned within the tri-lobed aperture, wherein the oval engaging portion is selectively shiftable in the tri-lobed aperture.

In a second aspect, the invention pertains to a cam for use in a hinge assembly, the cam including a body portion having a first end and a second end, an oval engaging  
20 portion oriented towards the first end, and a link engaging stud portion oriented towards the second end. In these embodiments, the oval engaging portion can be adapted to engage with and move within a corresponding aperture in a track such that the cam

member can be selectively shifted up to about thirty-five degrees longitudinally in either direction from a center position within the aperture.

In a third aspect, the invention pertains to a method of reducing sash sag, the method including adjusting an elongated arm connected to a cam member having an oval  
5 engaging portion, wherein the oval engaging portion is positioned within a tri-lobed aperture of a track.

#### Brief Description of the Figures

Fig. 1 is a perspective view of a casement window assembly;

10 Fig. 2 is a plan view of a hinge assembly of the present disclosure, wherein the hinge is depicted in the open position;

Fig. 3 is a top plan view of the track of the hinge assembly of the present disclosure;

Fig. 4 is a side plan view of the track of Figure 3;

15 Fig. 5 is a cross-sectional view of the hinge assembly of Fig.2 depicting the tri-lobed aperture and a cam member positioned within the tri-lobed aperture;

Fig. 6 is a perspective view of a cam member depicting an oval engaging portion that can engage a tri-lobed aperture;

20 Fig. 7 is a plan view of a cam member having an oval engaging portion positioned within a tri-lobed aperture, wherein the oval engaging portion is centered within the tri-lobed aperture;

Fig. 8 is a plan view of a cam member having an oval engaging portion positioned within a tri-lobed aperture, wherein the oval engaging portion is shifted to the maximum travel limit in one direction;

Fig. 9a is a side view of an embodiment of a cam member having a bullet shaped engagement portion;

Fig. 9b is a top view of the cam member of Fig. 9a;

Fig. 9c is a bottom view of the cam member of Fig. 9a;

Fig. 10a is a plan view of a hinge assembly having a generally pentagonal aperture;

Fig. 10b is an enlarged view of a portion of the plan view of Fig. 10a depicting the generally pentagonal aperture;

Fig. 10c is a perspective view of the cam member of Fig. 9a;

Fig. 10d is a plan view of a cam member having an oval engaging portion positioned within a tri-lobed aperture, wherein the oval engaging portion is centered within the tri-lobed aperture;

#### Detailed Description of the Invention

The present invention is an adjustable cam unit disposed within a casement window hinge for alleviating sash sag. As depicted in Fig.1, a conventional residential casement window assembly 10 generally includes a window frame 11 having two vertical frame members 12a, 12b, an upper horizontal frame 13 and a lower horizontal frame 14. Window assembly 10 also comprises a window sash 15, which includes an upper horizontal member 16, a lower horizontal member 17, vertical frame members 18a, 18b

and a glass panel 19. In general, window sash 15 is sized to closely fit within window frame 11 in order to seal out moisture and maintain the environment within the structure.

Window assembly 10 further generally includes upper and lower hinge assemblies 20a, 20b, which facilitate rotatably mounting the window sash 15 to the window frame 11. The hinge assemblies 20a, 20b generally include a track 22 mounted to the window frame 11, a sash arm 23 coupled to the window sash 15 and a support arm 24 mounted on a first end to the track 22 and to the sash arm 23 at the opposing end. The lower hinge assembly 20b is activated by rotating crank mechanism 26 so that window sash 15 pivots about the vertical axis. While the present description generally refers to casement windows, the present invention could be used with other types of window hinges including awning style windows.

Referring to Fig. 2, the improved hinge assembly 25 is depicted. The improved hinge assembly 25 includes a track 22, a sash arm 23, a support arm 24 mounted at a first end to track 22 by an adjustable cam 29 and at an opposing end to sash arm 23. Track 22 includes multiple anchoring holes 26 for mounting to a window frame 11 with screws, nails or other suitable fasteners. Sash arm 23 includes multiple anchoring holes 26 for mounting to a window sash 15 with screws, nails or other suitable fasteners.

Track 22 is operably connected to sash arm 23 through a slide block 27. Slide block 27 includes a pivotable connection 28 to sash arm 23 that allows for rotation of the sash arm 23 about the vertical axis. Slide block 27 is longitudinally slidable on track 22 so that the sash arm connection 28 may move longitudinally along track 22. Track 22 is also operably connected to support arm 24 through adjustable cam 29 that enables rotation about the vertical axis as well as selective longitudinal movement. Opposing end

of support arm 24 is mounted to a pivotable intermediate link 30 of sash arm 24 that allows for rotation about a vertical axis.

As depicted in Figs. 3 - 5, track 22 includes a flange 31 extending the length of track 22. The flange 31 extends over a limited portion of track 22 to form lip portion 33  
5 for guiding and locating slide block 27. The slide block 27 engages arcuate lip portion 33 of track 22 to permit longitudinal sliding movement along track 22 as sash arm 23 pivots during operation of hinge assembly 25. Track 22 has raised cam platform 34 defining pocket 35 between window frame 11 and track 22. In some embodiments, the side  
10 portions of raised cam platform 34 may be sloped from about 40 degrees to about 75 degrees relative to lower horizontal frame 14 of window frame 11. Pocket 35 allows for fastening of adjustable cam 29 to the underside or window frame side of track 22 as further described hereinbelow. Adjustable cam mounting hole 32 is defined in raised cam platform 34.

As depicted in Figs. 5 - 6, adjustable cam 29 generally includes cam body 29a,  
15 retainer 29b, and keeper 41. Cam body 29a presents first end 36 and second end 37 and is substantially symmetrical with respect to axis B-B. Link engaging stud portion 38 is oriented towards first end 37 and aperture-engaging portion 39 is oriented towards second end 37. Link engaging stud portion 38 defines groove 40 for receiving keeper 41 to pivotably secure support arm 24 to adjustable cam 29. In some embodiments, keeper 41  
20 can be an o-ring composed of metal, plastic, rubber or combinations thereof. As depicted in Fig. 6, keeper 41 is received in groove 40 to retain support arm 24 on link engaging stud portion 38. Additionally, cam body 29a include guide plate portion 42 positioned between link engaging stud portion 38 and aperture engaging portion 37. Guide plate

portion 42 is dimensioned so as to be larger than adjustable cam mounting hole 32, thereby preventing adjustable cam 29 from being drawn therethrough. Further, guide plate portion 42 may serve as a seat for guiding and supporting support arm 24.

Aperture engaging portion 39 generally includes post 43 and cam 44, both of which are substantially concentric with respect to axis B-B. In an embodiment of the invention, cam 44 may be generally oval shaped as depicted in Figs. 6-8 so as to conform with the edges 44a of adjustable cam mounting hole 32. Cam 44 and adjustable cam mounting hole 32 are coordinately dimensioned so that cam 44 is rotatably shiftable in adjustable cam mounting hole 32 about either or both vertical axes denoted A-A in the figures. It will be appreciated that, in other embodiments, cam 44 may have an elliptical shape or other shape enabling controlled rotational shifting within adjustable cam mounting hole 32. One of ordinary skill in the art will recognize that no particular shape of is required by the present disclosure. The shape of the stud is guided by the shape of the particular corresponding adjustable cam mounting hole 32 employed in a particular hinge assembly.

Retainer 29b is received on post 43 so as to retain adjustable cam 29 within adjustable cam mounting hole 32 on track 22. In an embodiment, retainer 29b may be a metal ring interference fit onto post 43 so as to clamp track 22 between retainer 29b and guide plate portion 42. In other embodiments, retainer 29b may be an O-ring, split ring, or the like, made from metal, plastic, rubber or combinations thereof.

The operation of adjustable cam 29 is depicted in Figs. 7 and 8. In the depicted embodiment, adjustable cam mounting hole 32 is a tri-lobed non-circular opening adapted to engage corresponding structure on adjustable cam 29. As described above,

cam 44 is oval shaped to conform with edges 44a of adjustable cam mounting hole 32. Cam 44, as depicted in Figs. 7 - 8, contacts track 22 at the endpoints 46, 47 of the major axis 48. Cam 44 is rotatably shiftable within adjustable cam mounting hole 32 about either or both of endpoints 46, 47, which coincide with axes A-A. By rotating adjustable  
5 cam 29, axis B-B, and post 37 which is concentric therewith, moves relative to the window frame 11 to shift the pivot point at which support arm 24 is pivotably connected with track 22. Adjustable cam 29 is held in the adjusted position solely by the frictional forces between adjustable cam 29 and track 22 resulting from the clamping force applied to track 22 by retainer 29b and guide plate portion 42. Significantly, there are no discrete  
10 structures such as serrations, or protrusions on either adjustable cam 29 or adjustable cam mounting hole 32 for mechanically locking the device in one position.

Referring to Fig. 7, cam 44 is centered in tri-lobed adjustable cam mounting hole 32. From this position, cam 44 can be shifted in either direction about endpoint 47, which facilitates shifting adjustable cam 29 and the attached support arm 24 relative to  
15 track 22. Referring to Fig. 8, adjustable cam 29 and oval stud 44 are depicted as being shifted to the maximum travel limit within tri-lobed adjustable cam mounting hole 32. Preferably, cam 44 and adjustable cam mounting hole 32 are dimensioned so as to enable up to about 35 degrees of rotation in either direction about endpoint 47 when cam 44 is centered in tri-lobed adjustable cam mounting hole 32 as depicted in Fig. 7.

20 An alternative embodiment is depicted in Figs. 9a-c and 10a-e for the adjustable cam. In the depicted embodiment, alternate adjustable cam mounting hole 132 has a "kernel-shaped" configuration. In these embodiments, as depicted in Figs. 9a-c, adjustable cam 129 includes a first end 136 and second end 137. Adjustable cam 129 can

Claims

What is claimed is:

1. A hinge assembly for a window comprising:
  - a window frame track disposed on a window frame, said window frame track having a raised cam platform, said raised cam platform defining a cam engaging aperture;
  - a sash arm extending from a window sash and pivotably coupled to a slide block that engages the window frame track;
  - a support arm pivotably coupled to the sash arm at a first end and coupled by an adjustable cam at a second end to the window frame track wherein said adjustable cam includes a link engaging stud portion separated from an aperture engaging portion by a support arm portion, the link engaging stud portion closely proportioned to an aperture in the support arm for rotation about a vertical axis, and the aperture engaging portion proportioned so that rotational movement of the adjustable cam results in longitudinal movement within the cam engaging aperture.
2. The hinge assembly of claim 1, wherein the window frame track comprises a plurality of fastener holes.
3. The hinge assembly of claim 1, wherein the window frame track further comprises an L-shaped track including a vertical flange having an overhang portion, the slide block being movable along the length of the L-shaped track.

4. The hinge assembly of claim 1, wherein the sash arm comprises a plurality of spaced apart fastener holes that facilitate coupling the sash arm to a window sash.
5. The hinge assembly of claim 1, wherein the link engaging stud portion further comprises a groove and a keeper member positioned within the groove, wherein the keeper member retains the support arm in contact with the link engaging stud portion of the adjustable cam.
6. The hinge assembly of claim 1, wherein the aperture engaging portion of the adjustable cam further comprises a post supporting a stud, the stud positioned for contact within the cam engaging aperture.
7. The hinge assembly of claim 6, wherein the post has a vertical dimension sufficient for attachment of a post keeper, said post keeper for maintaining the stud within the cam engaging aperture.
8. The hinge assembly of claim 6, wherein the post has a first end and a second end. said first end is in contact with the window frame.
9. The hinge assembly of claim 6, wherein the post has a cylindrical shape.
10. The hinge assembly of claim 6, wherein the post has a bullet shape.

11. The hinge assembly of claim 1, wherein the cam engaging aperture is a tri-lobed aperture.
12. The hinge assembly of claim 11, wherein the aperture engaging portion is selectively shiftable within the tri-lobed aperture up to about thirty-five degrees longitudinally in either direction from a center position within the tri-lobed aperture.
13. The hinge assembly of claim 1, wherein the cam engaging aperture has a kernel shape.
14. The hinge assembly of claim 13, wherein the aperture engaging portion has two contact points with a perimeter of the cam engaging aperture.
15. A method of reducing sash sag comprising:
  - connecting a window frame support arm to a window frame track with an adjustable cam;
  - rotating the adjustable cam, said adjustable cam having an aperture engaging portion sized to maintain frictional contact with a perimeter of a cam engaging aperture of the window frame track.
16. The method of claim 15, wherein the aperture engaging portion of the adjustable cam further comprises a post supporting an oval stud, the oval stud positioned for contact

within the cam engaging aperture, said post centered about the vertical axis of the aperture engaging portion.

17. The method of claim 16 wherein the cam engaging aperture is a tri-lobed aperture.

18. The method of claim 17, wherein the oval stud shifts within tri-lobed aperture up to about thirty-five degrees longitudinally in either direction from a center position within the tri-lobed aperture.

19. The method of claim 15, wherein the adjustable cam further comprises a groove and a keeper member positioned within the groove, wherein the keeper member retains the support arm about the adjustable cam.

20. The method of claim 15, wherein the aperture engaging portion of the adjustable cam further comprises a bullet shaped post supporting a pair of opposing teeth, said pair of opposing teeth extending from the bullet shaped post contact within the cam engaging aperture.

21. The method of claim 20 wherein the cam engaging aperture is kernel shaped.

22. A hinge assembly comprising:

a window frame track disposed on a window frame, said window frame track having a cam engaging portion defining a non-circular aperture;

a sash arm partially disposed on a window sash, the window sash sized to closely fit within the window frame, said sash arm pivotably coupled to the track through a slide block;

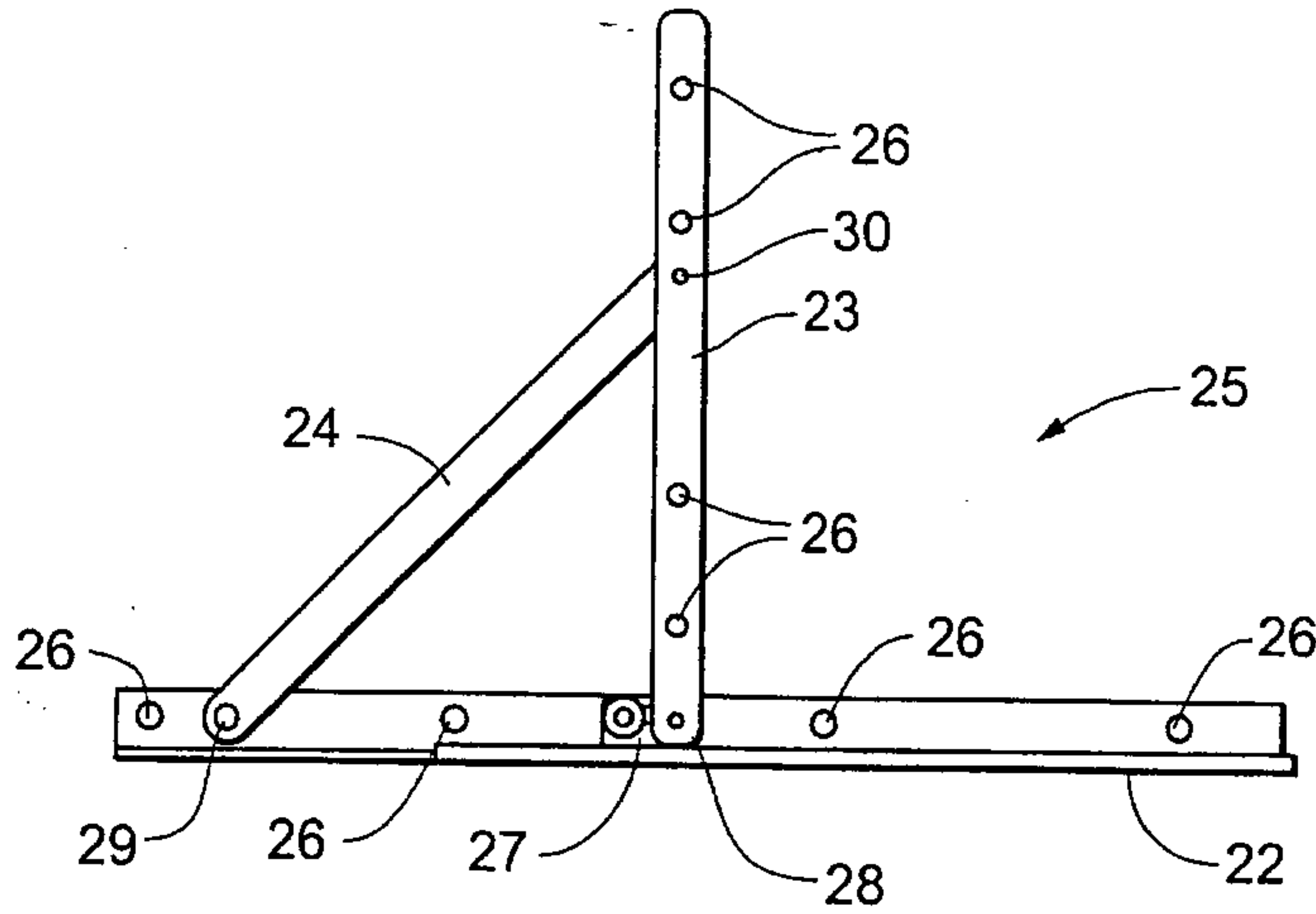
a support arm pivotably coupled at a first end to the window frame track and at a second end to the sash arm; and

means for adjusting window sash alignment, said means including an adjustable cam connecting the support arm to the window frame track, the adjustable cam having a first end set at a fixed point along a vertical axis on the support arm and a second end set within the non-circular aperture, the second end of the adjustable cam including a center post and a pair of parabolic studs disposed on opposing sides of the center post for contact with a perimeter wall of the non-circular aperture.

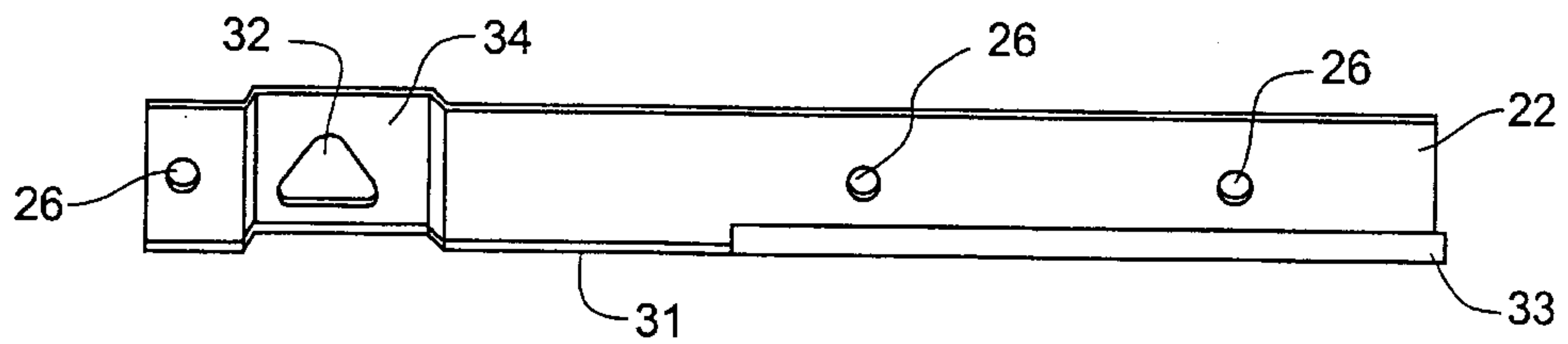
23. The hinge assembly of claim 22 wherein the non-circular aperture is kernel shaped.
24. The hinge assembly of claim 22 wherein the non-circular aperture is tri-lobed shaped.
25. The hinge assembly of claim 22 wherein rotation of the adjustable cam causes the adjustable cam post to trace an arcuate path across the non-circular aperture.



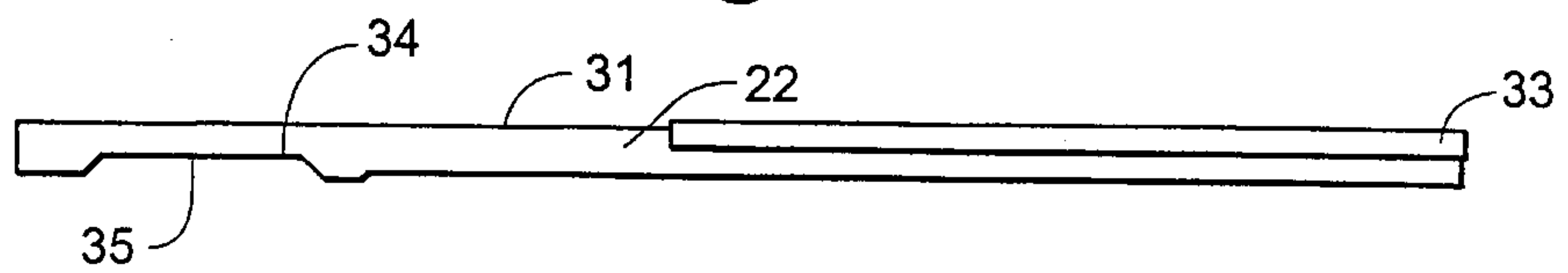
**Fig. 2**



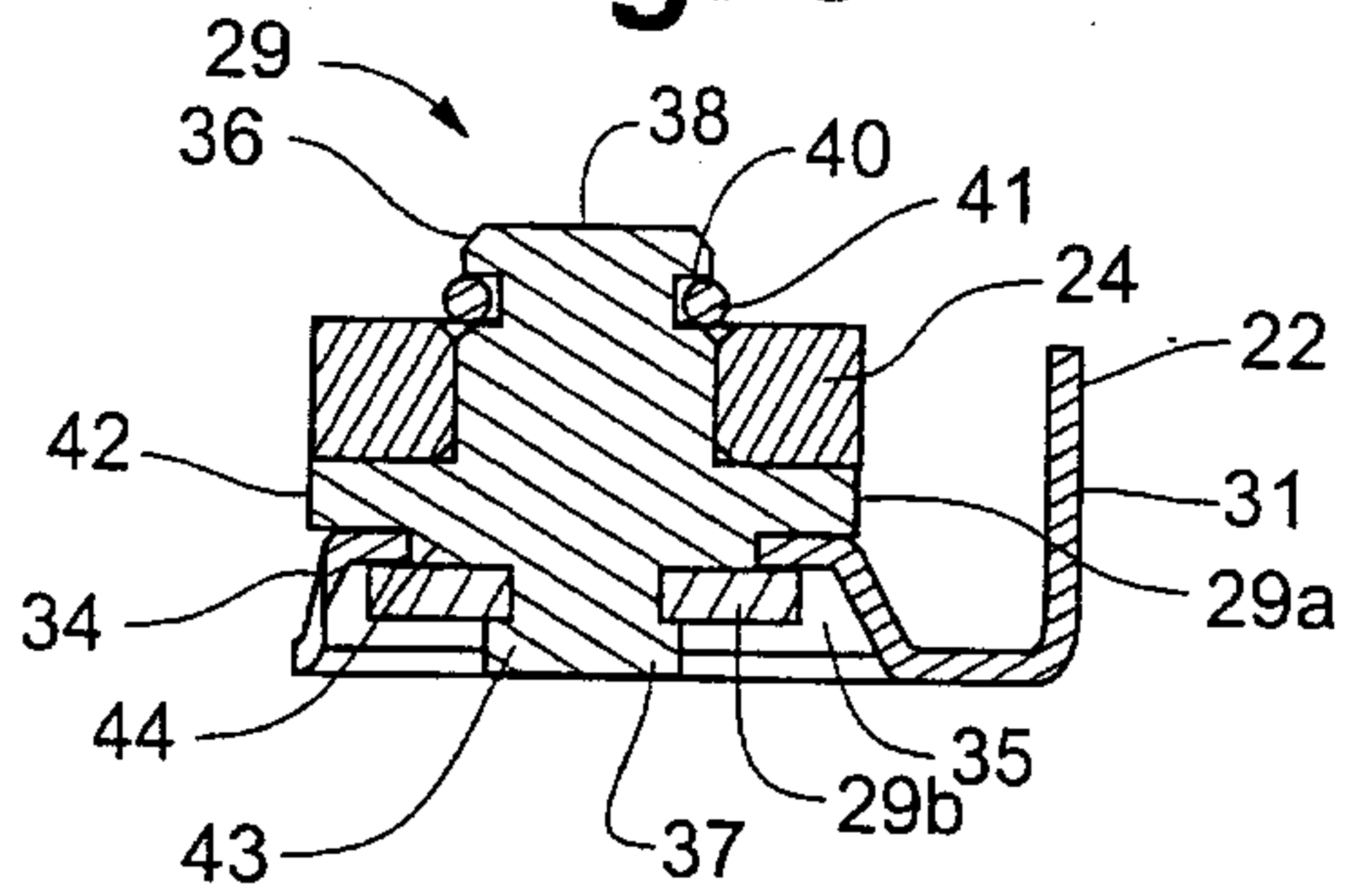
**Fig. 3**



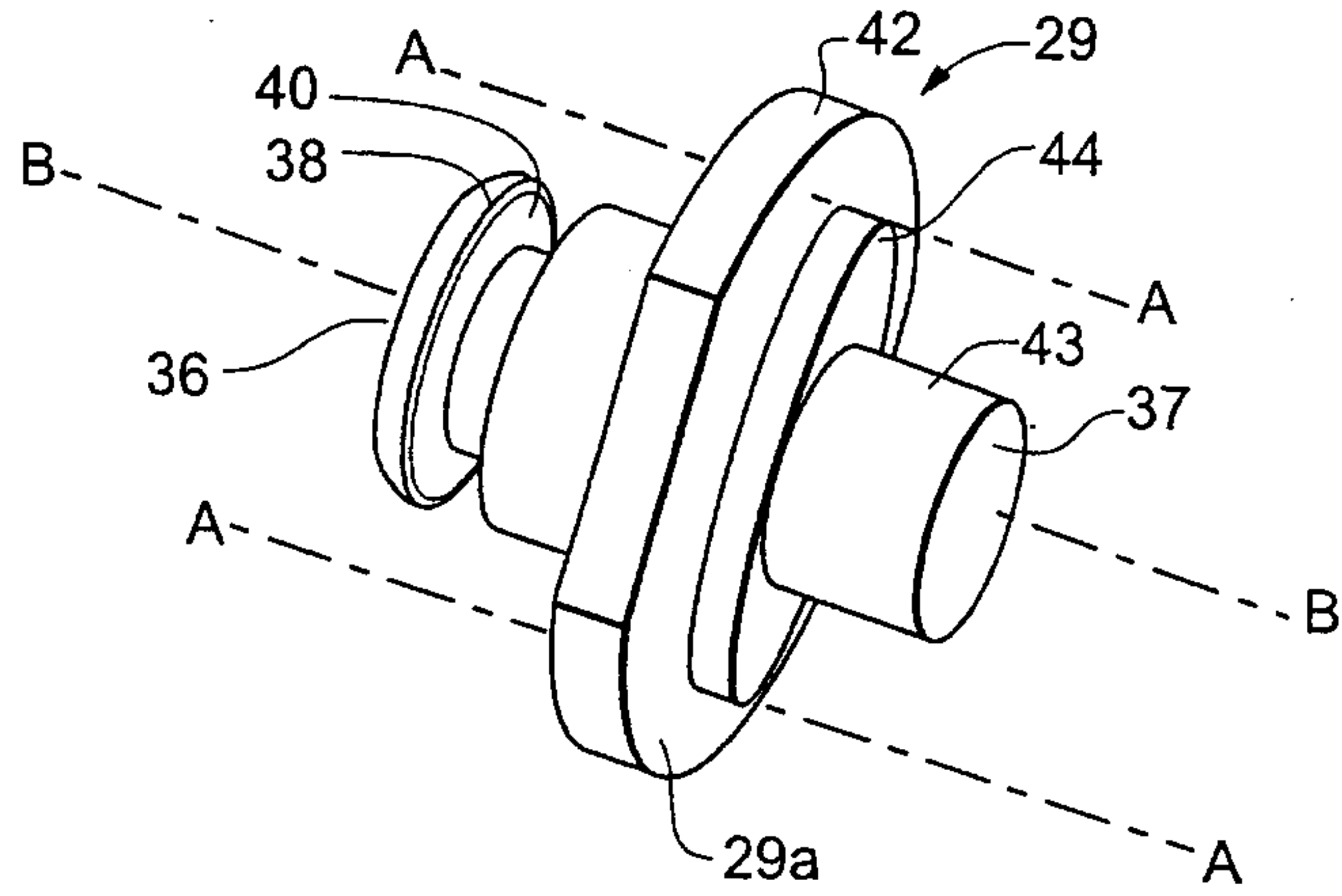
**Fig. 4**



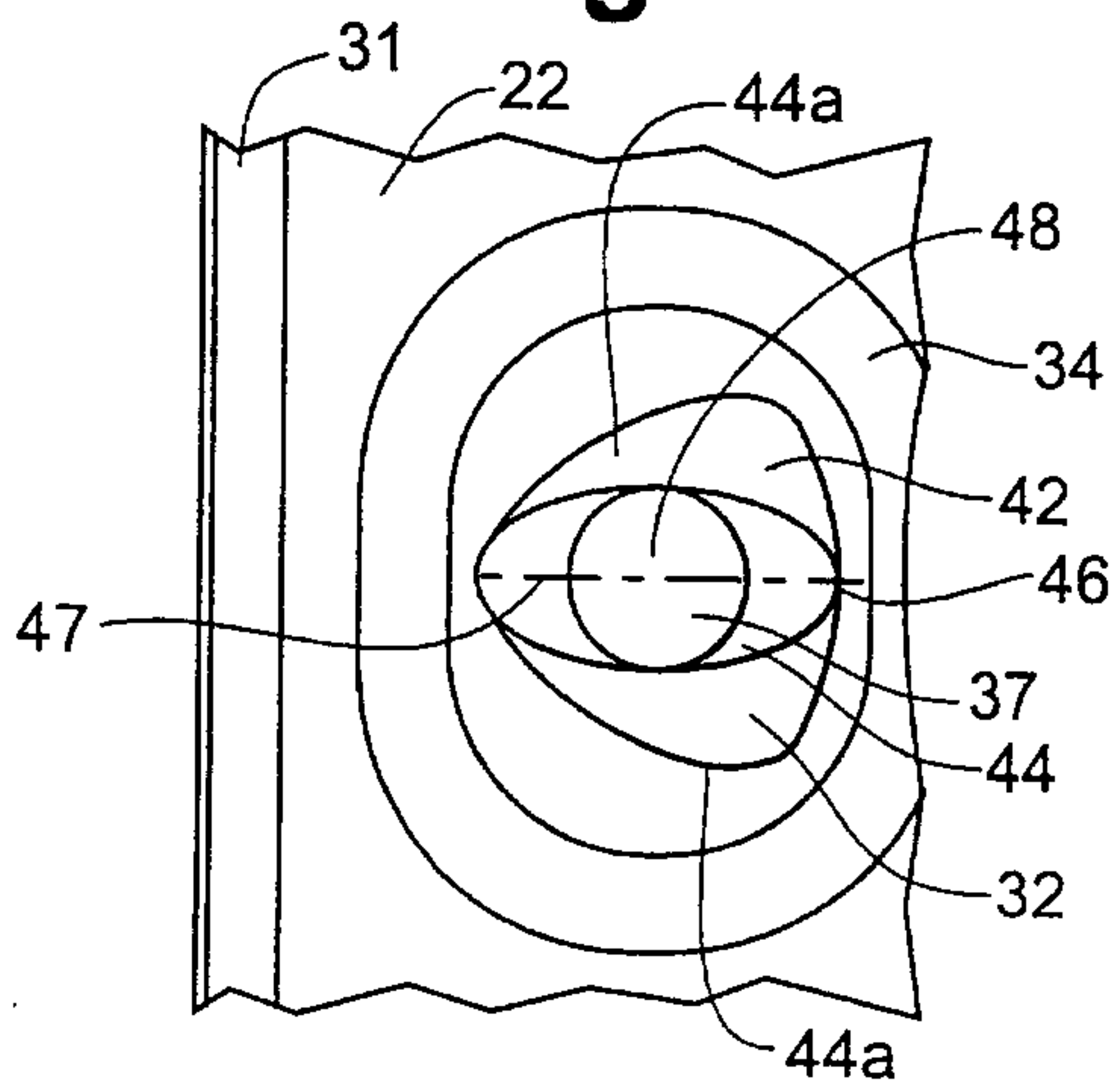
**Fig. 5**



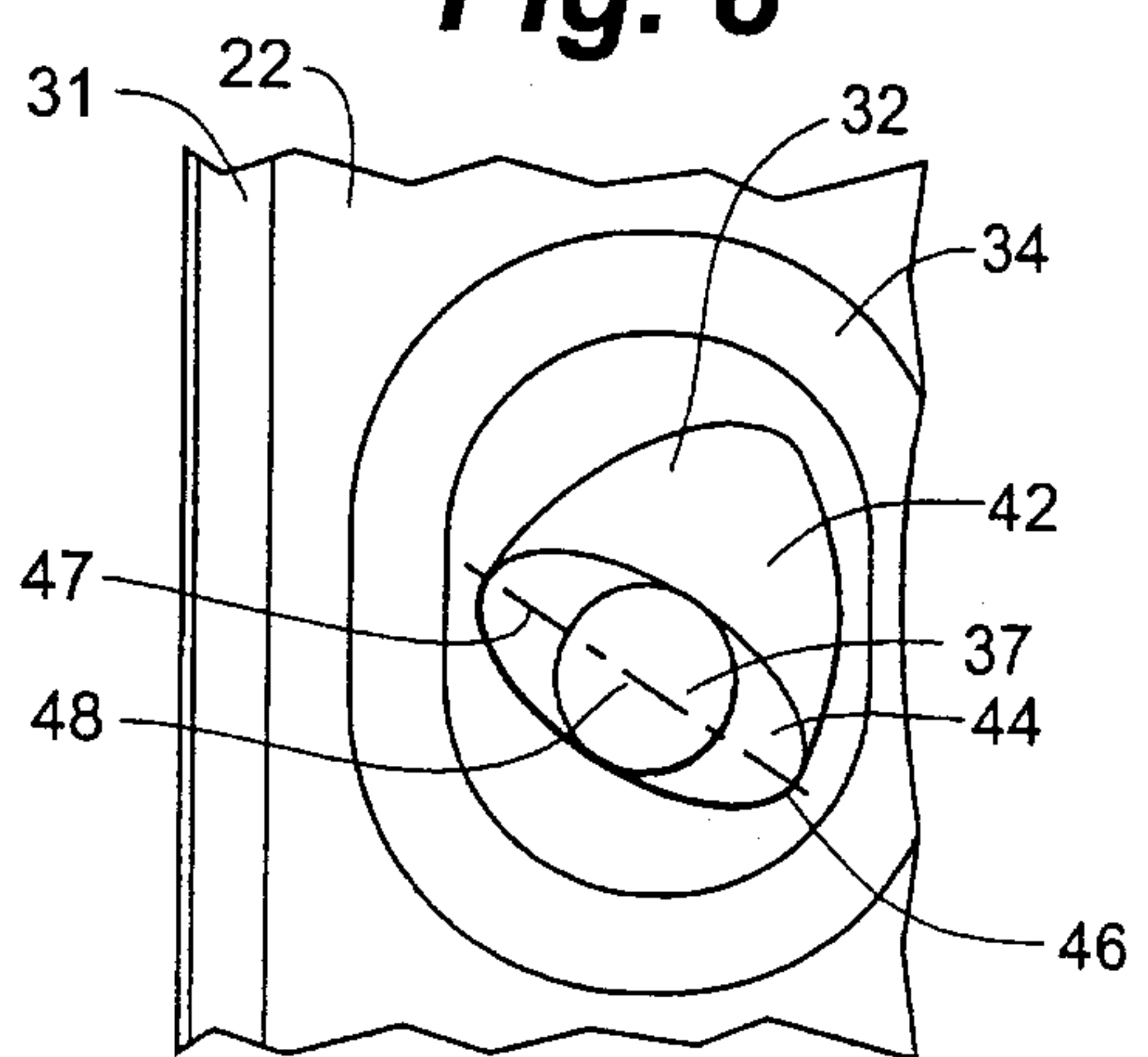
**Fig. 6**



**Fig. 7**

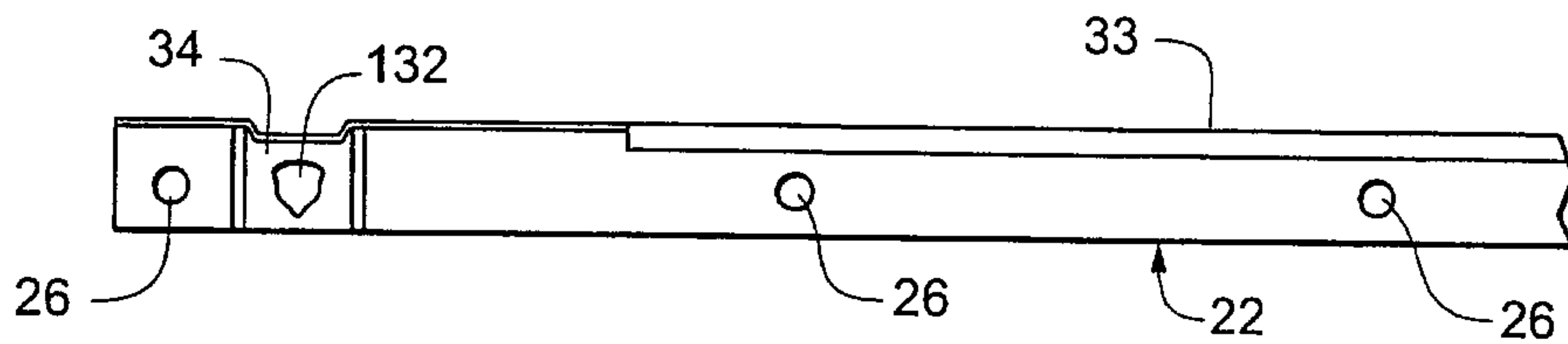


**Fig. 8**

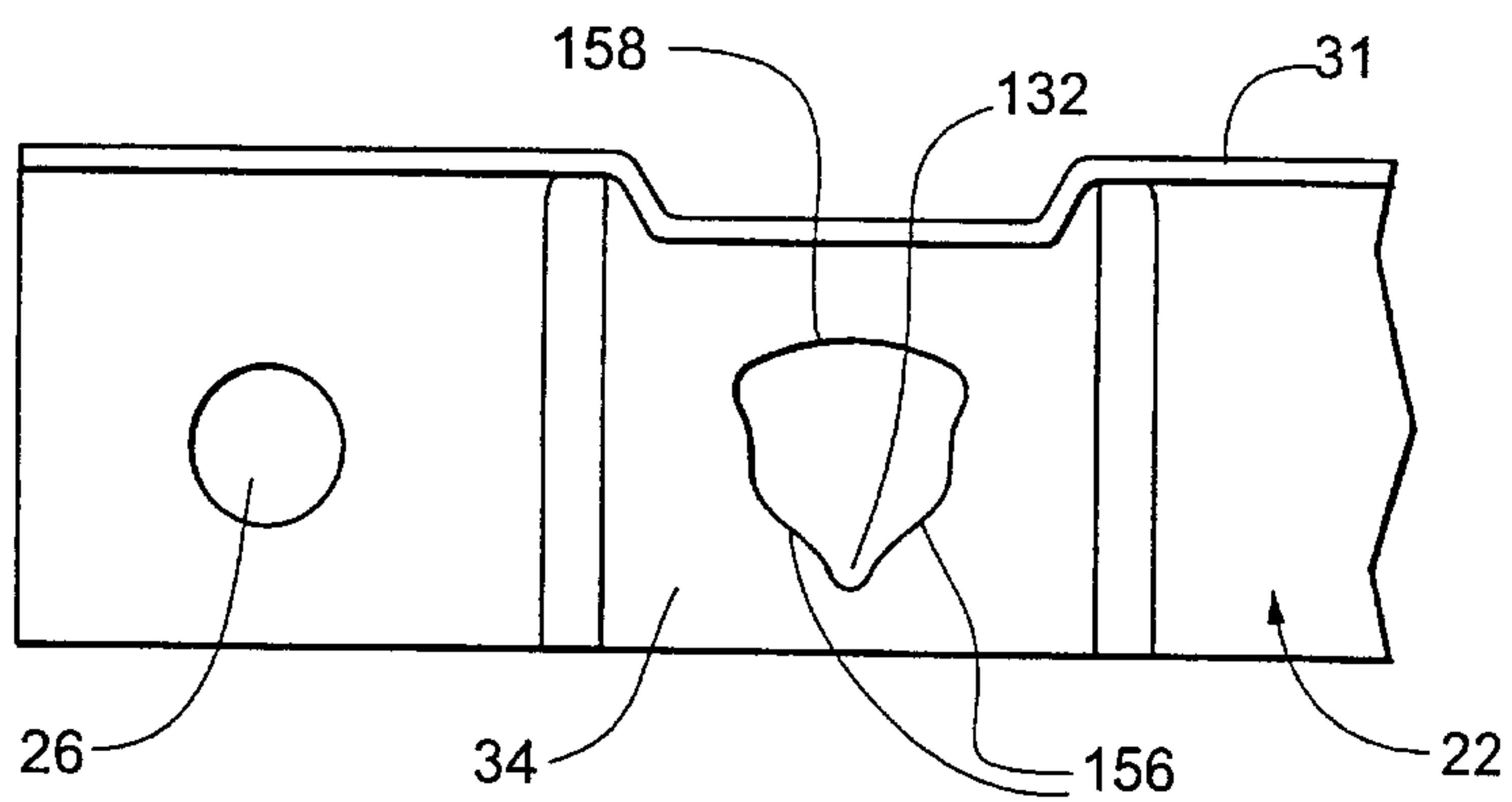




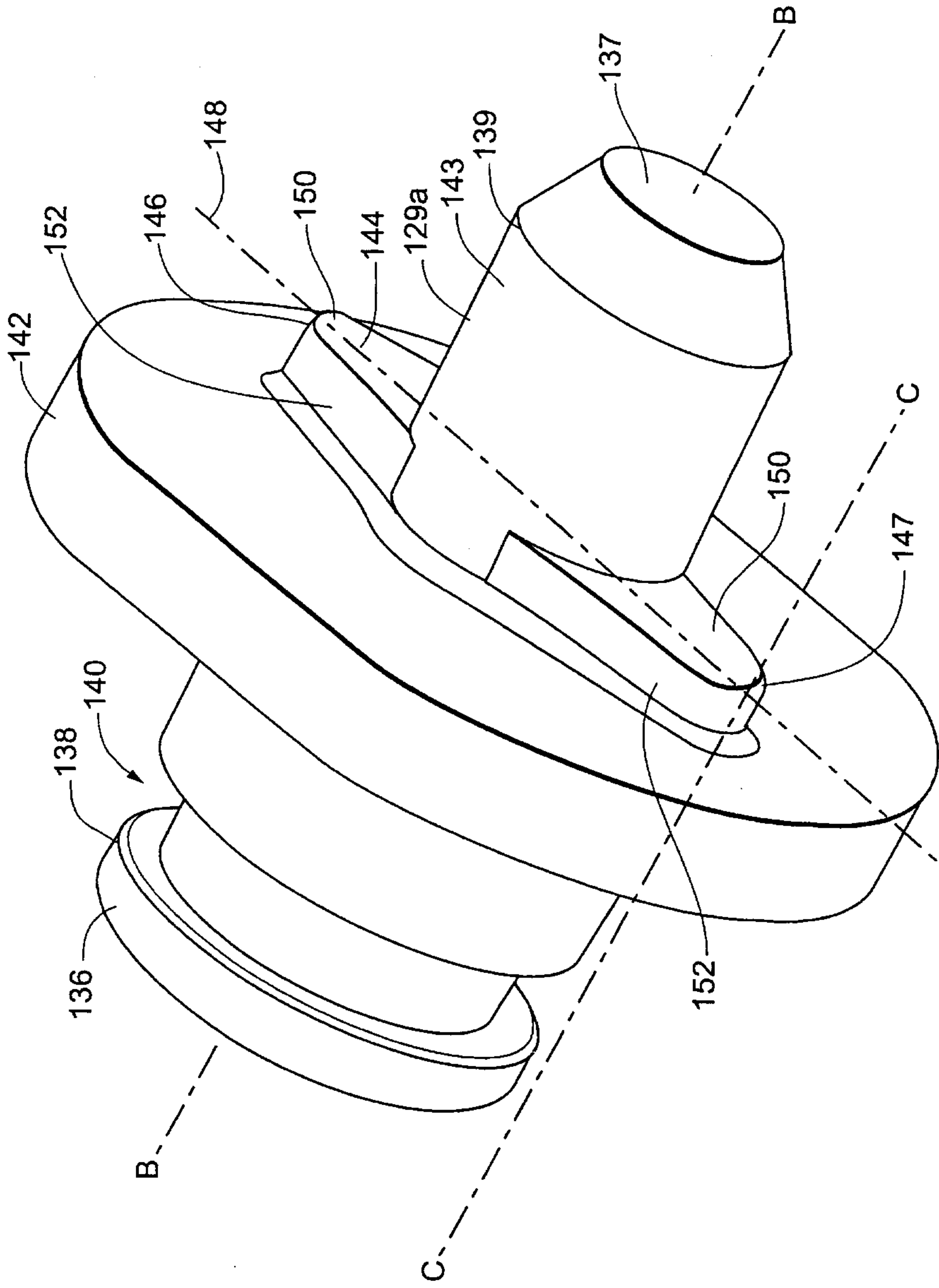
**Fig. 10a**



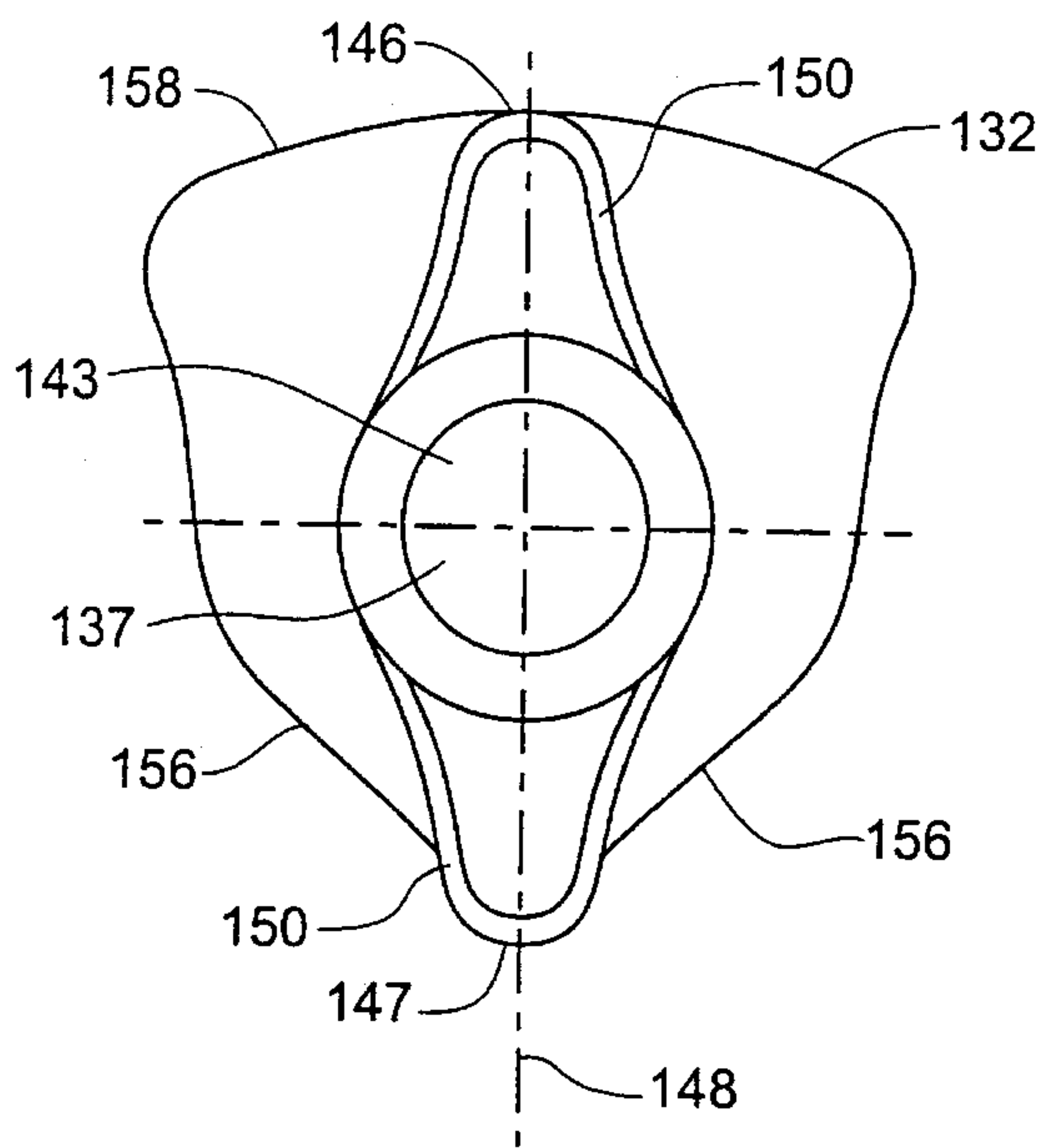
**Fig. 10b**



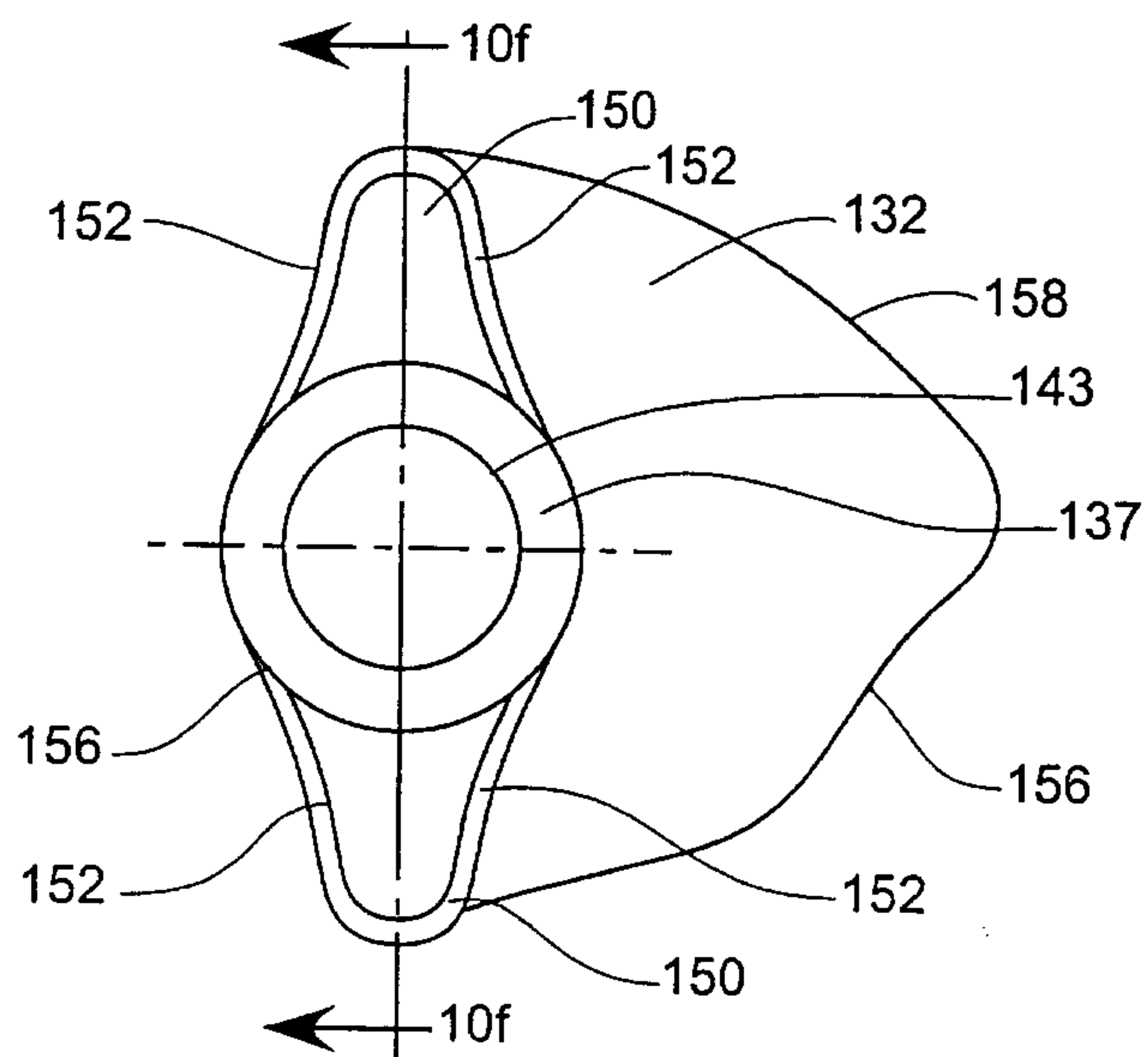
**Fig. 10c**



**Fig. 10d**



**Fig. 10e**



**Fig. 10f**

