

T. H. GREENWOOD.
BOBBIN BUILDER FOR MULES.

No. 246,306.

Patented Aug. 30, 1881.

Fig:1.

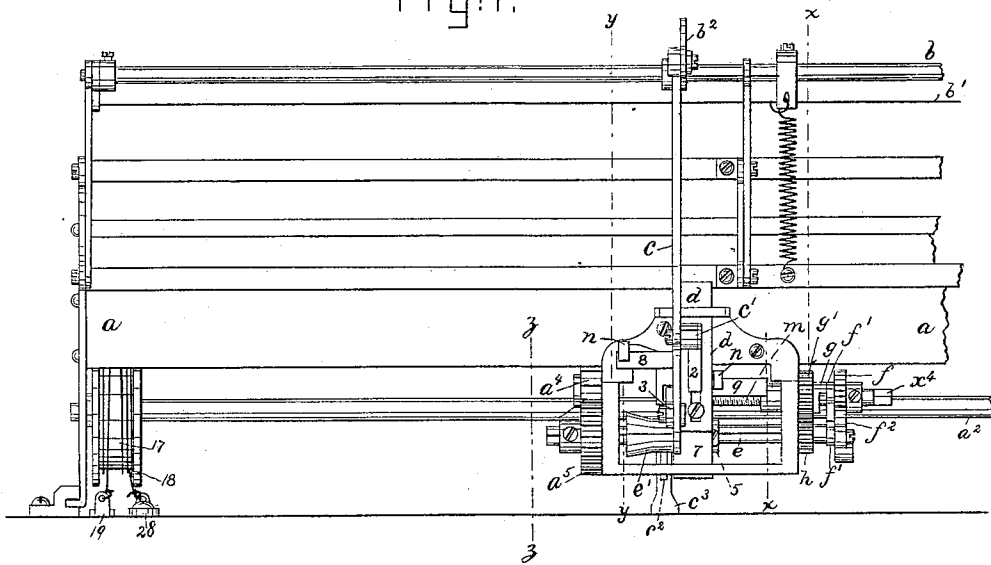

Fig:4.

Fig:2.

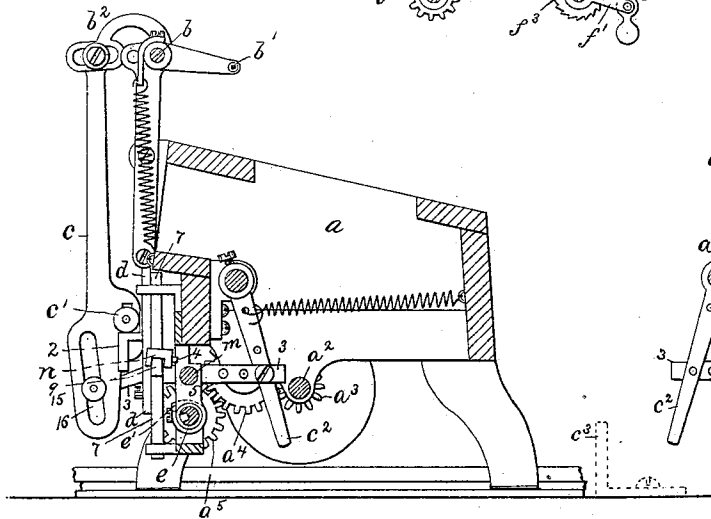
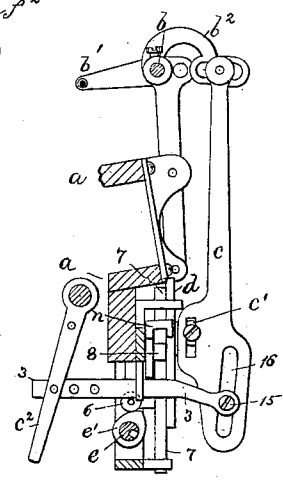

Fig:3.



WITNESSES.

Reynolds
A. C. Whitney.

INVENTOR—

Thomas H. Greenwood.
by Crosby Gregory Attys

T. H. GREENWOOD.
BOBBIN BUILDER FOR MULES.

No. 246,306.

Patented Aug. 30, 1881.

Fig: 5.

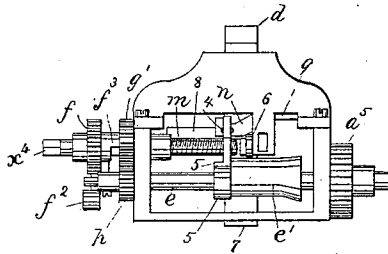

Fig: 6.

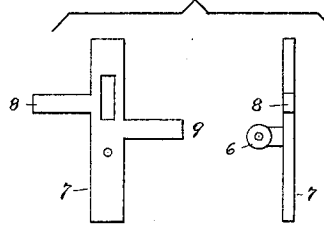

Fig: 7.

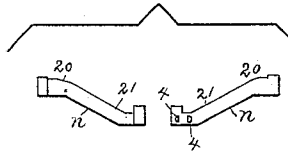

Fig: 8. Fig: 10.

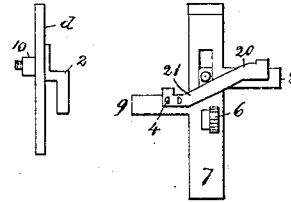

Fig: 9.

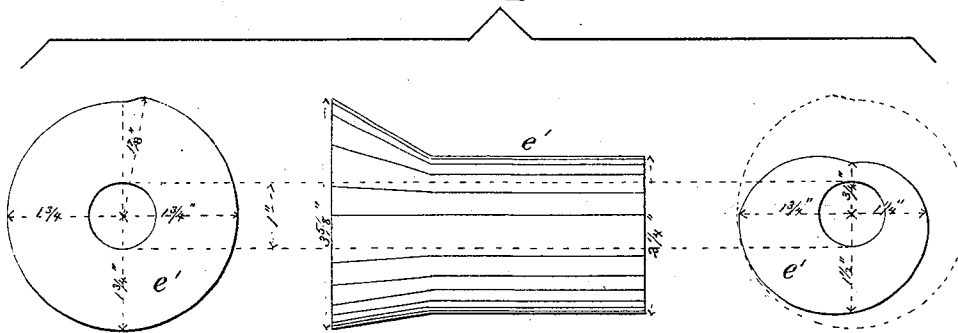

Fig: 11.

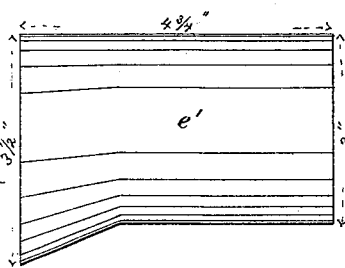
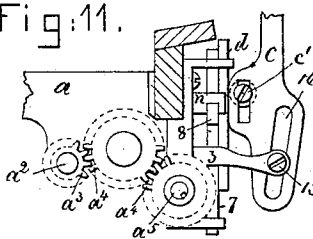
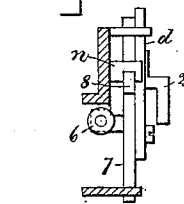

Fig: 12.



WITNESSES.

A. Reynolds
M. E. Whitney

INVENTOR.

Thomas H. Greenwood
by Crosby & Morgan Attys

UNITED STATES PATENT OFFICE.

THOMAS H. GREENWOOD, OF GILBERTVILLE, ASSIGNOR TO DAVIS & FURBER, OF NORTH ANDOVER, MASSACHUSETTS.

BOBBIN-BUILDER FOR MULES.

SPECIFICATION forming part of Letters Patent No. 246,306, dated August 30, 1881.

Application filed September 29, 1880. (No model.)

To all whom it may concern:

Be it known that I, THOMAS HENRY GREENWOOD, of Gilbertville, county of Worcester, State of Massachusetts, have invented an Improvement in Bobbin-Builders for Mules, of which the following description, in connection with the accompanying drawings, is a specification.

This invention relates to self-acting mules, and is especially applicable to that class of mule represented in United States Patent No. 193,887, August 7, 1877, but may be applied to other well-known classes of mules.

This invention has for its object, among other things, a novel mechanism for controlling the building or winding of the yarn upon the bobbin. This mechanism, as herein shown, derives its movement from the squaring-shaft carried by the carriage, the said shaft having suitable gear-wheels to operate a shaft having an irregular cam, which, besides being rotated by, also slides upon, the said shaft. This cam acts upon a roller or other stud connected with what I denominate the "back slide," moving it vertically or up and down at each complete rotation of the cam-shaft, which rotation is completely effected in one direction during each inward traverse of the carriage, the next outward traverse of the carriage turning it backward to its starting-point. This back slide has upon its arms a cam-shaped shoe, which, besides rising and falling with the back slide, is also moved horizontally on the arms of the back slide in unison with the cam before referred to, the shoe being connected by lugs with the same nut which imparts longitudinal movement to the cam. The lug-connection of the shoe with the said nut is such as to permit the shoe and back slide to rise and fall without disturbing the connection of the lug with the nut. The cam-surface or inclined upper face of the shoe serves to support a loosely-held auxiliary slide having only vertical movement. This latter slide has a shoulder to receive upon it an adjustable projection connected with the faller-lock, it being a link adjustably attached to an arm of the faller-shaft. The projection of the faller-lock is placed upon the shoulder of the auxiliary slide when the carriage is at the end of its outer traverse,

having stretched the yarns, the auxiliary slide then being in its lowest position; and as the carriage is being moved toward the head-stock or delivery-rollers this auxiliary slide is raised, and with it the faller-lock, thus depressing the faller to guide the yarn down on the rotating bobbin; but the yarn having reached its lowest position—that depending upon the position of the shoe, which is shifted as the bobbin increases in size—the auxiliary slide and also the back slide and shoe are permitted by the shape of the cam on the cam-shaft to descend, when the faller-lock also descends, lifting the faller, the yarn following it to the top of the "chase," and when the carriage arrives at the head-stock the lower end of the faller-lock is detached from the shoulder of the auxiliary slide through a lever on the carriage, which at that time strikes an adjustable stop on the floor, the lever being adjustably connected by a link with the faller-lock. The carriage is then traversed outward, while the faller is lifted, and the cam on the cam-shaft is reversed or turned in the opposite direction. At each outward movement of the carriage when the rotation of the cam is reversed, as described, it and the shoe are moved longitudinally for a short distance, according to the diameter of the filled bobbin.

Figure 1 represents, in front elevation, a sufficient portion of a self-acting mule to illustrate my improvements; Fig. 2, a partial section thereof on the line *xx*, Fig. 1; Fig. 3, a partial section on the line *yy*; Fig. 4, details showing the ratchet and loose gear on the screw-shaft, to be referred to; Fig. 5, a rear elevation of the cam-shaft, cam thereon, screw-shaft, nut, and means to move the screw-shaft from the cam-shaft; Fig. 6, a front view and side elevation of the back slide; Fig. 7, a front and rear view of the shoe; Fig. 8, a side elevation of the auxiliary slide; Fig. 9, side views and end elevations of the building-cam on a larger scale, its actual dimensions being marked thereon. Fig. 10 is a rear-side elevation of the back slide, shoe, and auxiliary slide in operative position with relation to each other; Fig. 11, a sectional detail on the dotted line *zz*, Fig. 1, looking toward the right, to show the means for operating the shaft of the builder-

cam from the squaring-shaft of the carriage; and Fig. 12, a detail left-side elevation of the back slide, shoe, and auxiliary slide, and the guides for the said slides.

5 The mule-carriage *a*, having spindles of any usual kind and driven in the ordinary manner, will, in practice, be mounted upon wheels, and will be made to traverse backward and forward with relation to the delivering-rolls in the usual
10 fixed part of the frame, not necessary to be herein shown.

The faller-shaft *b*, faller *b'*, and its arm *b²* are all as common, and will in practice be accompanied by the usual counter or tension faller and its operative mechanism. (Not shown.)

15 The faller-lock *c*, shown as a link adjustably connected at its upper end with the slotted part of the arm *b²*, has adjustably secured to it a projection, *c'*, made as a roller which is
20 lifted and seated upon the shoulder 2 of the auxiliary slide *d*, after the carriage reaches its outward movement, the upward movement of the faller-lock for this purpose being produced through the devices of the usual backing-off
25 mechanism, which mechanism operates to turn the faller-shaft and depress the faller after the twist is put into the yarn and just previous to the commencement of the inward run of the carriage, such mechanism being omitted because it is common to self-acting mules of the kind represented in United States Patent No. 113,784, to McGovern. The lower end of the faller-lock *c* is loosely connected by link 3 with
30 the pivoted lever *c²*, the lower end of which, at the end of inward traverse, strikes the stop *c³*, adjustably connected with the floor upon which the mule rests, to, at the proper time, throw the faller-lock backward off from the shoulder 2 of the auxiliary slide and permit the faller
40 to rise and the faller-lock to drop down. In Fig. 2 I have shown this stop in dotted lines.

The squaring-shaft *a²* is the same as in the patent referred to, and has drums 17 at each end, each drum having wound about it a squaring-band, 18, the ends of which are fixed to eyes 19 28 on the floor. It being driven by the squaring-bands, I employ it as the source of motion for my improved building mechanism. Upon this shaft *a²* is a pinion, *a³*, that, through
50 an idle-wheel, *a⁴*, in engagement with the pinion *a³*, fast on the cam-shaft *e*, turns the said shaft at the proper speed. This shaft *e* has upon it the builder-cam *e'*, it being feathered thereon, so as to rotate with the shaft, but so
55 as to be moved longitudinally thereon at the proper times by the screw-shaft *m*, entered into a nut, 5, attached to one end of said cam. This screw-shaft has connected with it a ratchet, *f*, and at the side of the said ratchet is a pawl-carrying arm, *f'*, having an attached weighted pawl, *f²*. This arm *f'* at the inner face of the hub is provided with a projection, *f³*, (see Fig. 4,) which is engaged by a similar projection, *g*, on the gear *g'*, loose on the screw-shaft. This loose gear is partially rotated
65 on the screw-shaft in first one and then in the other direction by each outward and in-

ward movement of the carriage through or by means of the smaller gear *h*, adjustably attached to the cam-shaft *e*. This gear *h* has
70 about half the number of teeth as the gear *g'*, and is secured to the cam-shaft, which, as has been stated, is rotated once in one and then in the reverse direction, and as the teeth of the gears *g'* and *h* are always in engagement,
75 it will be obvious, by partially rotating the gear *h* about the axis of the shaft *e*, that the said gear acting on the gear *g'* will so change the position of gear *g'* circumferentially that the projection *g* of the gear *g'* will be brought,
80 in the movement of the said gear, in contact, sooner or later, with the projection *f³* of the pawl-carrying arm *f'*, and consequently move the said pawl a greater or less distance, causing it to turn the screw-shaft more or less,
85 according to the desired diameter of the filled bobbin. The turning of the screw-shaft, acting on the nut 5, gradually moves the builder-cam longitudinally on its shaft, in order that the chase or wind of the bobbin may be gradually lengthened during the formation of the bottom of the cop or bobbin. As soon as the bottom of the cop or bobbin is established the chase is thereafter uniform, notwithstanding the movement of the cam longitudinally is continued, for the roller or stud 6 on the back slide, 7, then rests upon a portion of the builder-cam of uniform contour in the direction of its length. This back slide, moved vertically by the builder-cam, has two arms, 8 9, to support loosely the shoe *n*, (shown separately in Fig. 7,) it having an inclined or cam-shaped top or surface to receive upon it a pin, 10, connected with the auxiliary slide *d*. (Shown in detail, Fig. 8.) This shoe is formed at its ends to embrace the arms 8 9 of the back slide, and at the rear of the shoe (see Fig. 7) are two lugs, 4, that embrace the edge of the nut 5, so that the said nut, as it moves the cam, also moves the shoe longitudinally in unison with
100 the cam, the shoe at the same time being moved vertically, as it must be, with the back slide, without breaking its connection with the nut.

The builder-cam (see Fig. 9) is of an irregular heart shape in cross-section. A true heart-cam gives the same throw at each half-rotation; but in the cam employed by me the heart is of such cross-section that one-fourth of its circumference gives the same throw as the remaining three-fourths, to thus enable the said cam *e'* to operate the faller and cause the yarn to be wound more or less open during the descent of the faller than during the upward movement of the said faller. This cam
115 at its largest end is of such diameter as to give a throw to the faller of about three-fourths of an inch, and at its smallest end from two to two and one-half inches. When commencing to form a set of bobbins the roller or stud of the back slide rests upon the large end of the builder-cam. As the formation of the bottom of the bobbin proceeds it becomes necessary to lengthen the chase until the bottom is fully

formed, after which the chase is of uniform length. To provide for this variation in the chase the heart is so shaped in the direction of its length as to gradually increase the throw of the back slide operated by it until the bottom or base of the bobbin is fully formed or shaped, after which the heart gives the back slide a uniform throw until the bobbin is fully wound.

The chase may be varied in length by adjusting the connection of the faller-lock with the arm b^2 of the faller-shaft.

During the winding motion the shoe is progressively moved longitudinally, so as to gradually lower the auxiliary slide, permitting its pin 10 to travel down the inclined top of the shoe. The top of the shoe has two inclines, (see Fig. 7,) marked 20 and 21. When the bottom of the bobbin is being formed the pin rests on the incline 20 at the end of the shoe, and descends for a less distance at each traverse of the carriage than when the pin rests upon the surface 21, or longer incline, as it does after the bobbin is formed. As the pin 10 descends along the inclines the position of the auxiliary slide is so changed that it acts upon the faller b' to place and keep it in such position that the lowermost turn of thread for each chase shall be a little higher on the bobbin than the one preceding it. The short incline 20 of the shoe and that part of the builder-cam which operates during the time the bottom of the bobbin is being formed are so proportioned with relation to each other that the pin on the auxiliary slide does not leave the short incline until just as that part of the builder-cam which is to give the regular chase comes into operative position. To return the builder-cam e' to its starting position after completing a set of cops or bobbins, the operator will apply a crank to the squared end x^4 of the screw-shaft m , lift the pawl f^2 from the ratchet f , and turn the said screw-shaft in the opposite direction, so that the nut 5 thereon will be moved back, it moving with it the shoe n and builder-cam.

Adjustment of the roll e' adapts the faller to bobbins of different length.

Instead of driving the cam-shaft from the

squaring-shaft, it may be driven from any other proper source—as, for instance, a rack on the floor.

I claim—

1. In a mule, the faller and faller-lock, combined with the auxiliary slide to co-operate therewith, the shoe, and back slide, and the builder-cam, and mechanism to both rotate and reciprocate it, substantially as described.

2. In a mule, the carriage and its squaring-shaft a^3 , and means to turn it, combined with the cam-shaft e and building-cam e' , and intermediate connections between the said cam-shaft and squaring-shaft, to rotate the cam-shaft and building-cam from the squaring-shaft during the building of the bobbin, substantially as described.

3. In a bobbin-builder, the cam-shaft, builder-cam, and mechanism to rotate it, the screw-shaft, nut moved by it, the ratchet, the pawl-carrier provided with a projection, and the pawl, combined with the loose gear provided with the projection to engage the projection of the pawl-carrier, and the adjustable gear located on the cam-shaft and engaged with the loose gear on the screw-shaft, to govern the extent of movement of the screw-shaft, nut, and builder-cam according to the desired diameter of the filled bobbin, substantially as described.

4. In a bobbin-builder for mules, the builder-cam, its shaft, and means to rotate it, a nut connected therewith, and a single screw-shaft and means to turn it intermittently, combined with the faller, the back slide, and its shoe having an inclined surface, and with suitable mechanism to connect the faller and shoe, the shoe being adapted to be moved in unison with the builder-cam, the change of position of the shoe and the said back slide controlling the extent of throw or movement of the faller, substantially as described.

In testimony whereof I have signed my name to this specification in the presence of two subscribing witnesses.

THOMAS H. GREENWOOD.

Witnesses:

G. W. GREGORY,
N. E. C. WHITNEY.