



US00RE49608E

(19) **United States**
(12) **Reissued Patent**
Chen

(10) **Patent Number:** **US RE49,608 E**
(45) **Date of Reissued Patent:** **Aug. 15, 2023**

(54) **TWO-WHEEL SELF-BALANCING VEHICLE WITH INDEPENDENTLY MOVABLE FOOT PLACEMENT SECTIONS**

(71) Applicant: **SOLOWHEEL INC.**, Camas, WA (US)

(72) Inventor: **Shane Chen**, Camas, WA (US)

(21) Appl. No.: **16/000,535**

(22) Filed: **Jun. 5, 2018**

Related U.S. Patent Documents

Reissue of:

(64) Patent No.: **8,738,278**
Issued: **May 27, 2014**
Appl. No.: **13/764,781**
Filed: **Feb. 11, 2013**

U.S. Applications:

(63) Continuation of application No. 15/165,654, filed on May 26, 2016, now Pat. No. Re. 46,964, which is an application for the reissue of Pat. No. 8,738,278.

(Continued)

(51) **Int. Cl.**
B60L 15/20 (2006.01)
B62K 11/00 (2006.01)
B60L 1/00 (2006.01)

(52) **U.S. Cl.**
CPC **B60L 15/20** (2013.01); **B62K 11/007** (2016.11); **B60L 2200/16** (2013.01);
(Continued)

(58) **Field of Classification Search**
CPC .. B62D 1/00; B62D 1/02; B60L 15/20; B60L 2260/34; B60L 2200/16; B62K 3/02;
(Continued)

(56) **References Cited**

U.S. PATENT DOCUMENTS

5,131,875 A 7/1992 Lee
6,302,230 B1 10/2001 Kamen
(Continued)

FOREIGN PATENT DOCUMENTS

CN 2486450 Y 4/2002
CN 100431906 C 11/2008
(Continued)

OTHER PUBLICATIONS

United States Court of Appeals for the Federal Circuit Court, No. 2017-2591, *Razor USA LLC, Inventist, Inc. and Shane Chen v. International Trade Commission and Hangzhou Chic Intelligent Technology Co., Ltd., Alibaba Group Holding Ltd. and Alibaba.com Limited., Swagway, LLC, and Jetson Electric Bikes, LLC.*, Investigation No. 337-TA-1000, Reply of Appellee U.S. International Trade Commission to Appellants' Response to the Commission's Motion for Dismissal of the Appeal, May 25, 2018, 52 pages.

(Continued)

Primary Examiner — Jeffrey D Carlson

(57) **ABSTRACT**

A two-wheel, self-balancing personal vehicle having independently movable foot placement sections. The foot placement sections have an associated wheel, sensor and motor and are independently self-balancing which gives the user independent control over the movement of each platform section by the magnitude and direction of tilt a user induces in a given platform section. Various embodiments are disclosed including those with a continuous housing, discrete platform sections and/or tapering platform sections.

4 Claims, 4 Drawing Sheets

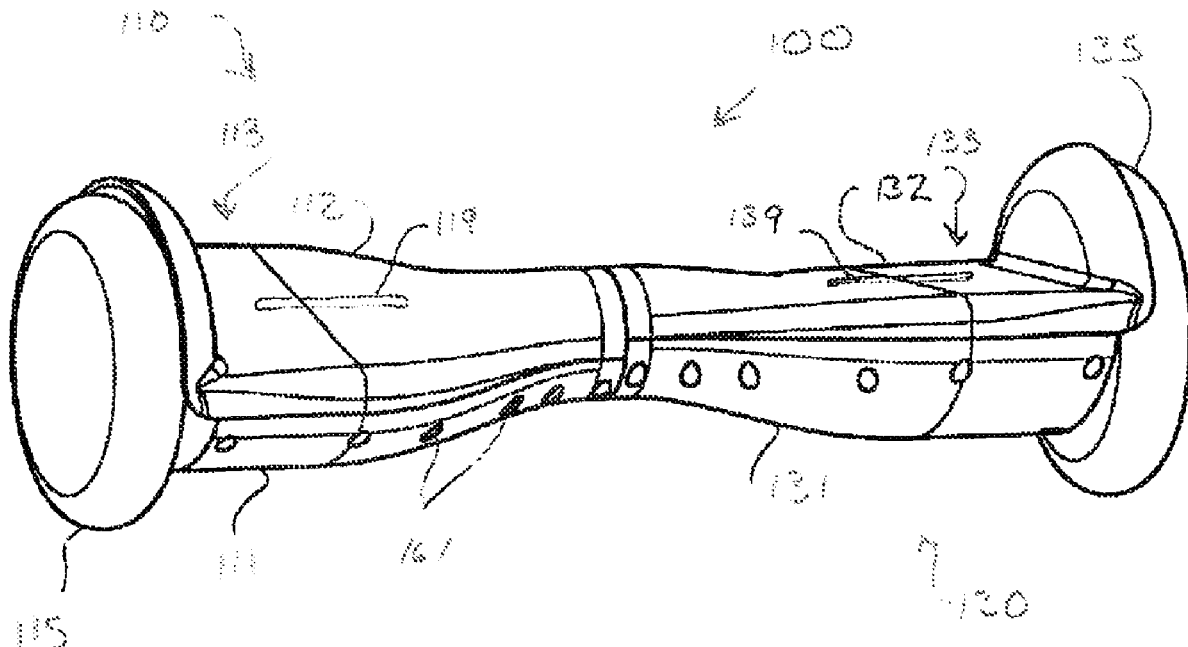

Related U.S. Application Data

- (60) Provisional application No. 61/597,777, filed on Feb. 12, 2012.
- (52) **U.S. Cl.**
CPC B60L 2260/34 (2013.01); Y02T 10/64 (2013.01); Y02T 10/72 (2013.01)
- (58) **Field of Classification Search**
CPC B62K 3/06; B62K 11/00; B62K 11/07; B62K 17/00; B62K 21/00; B62K 21/22; B62K 23/08; B62K 2202/00; B62K 11/007

See application file for complete search history.

2010/0225080	A1	9/2010	Smith	
2010/0237645	A1*	9/2010	Trainer	296/21
2011/0131759	A1	6/2011	An	
2011/0209929	A1*	9/2011	Heinzmann et al.	180/6.2
2011/0220427	A1*	9/2011	Chen	180/21
2011/0221160	A1*	9/2011	Shaw	280/205
2011/0238247	A1*	9/2011	Yen et al.	701/22
2011/0282532	A1	11/2011	Kosaka et al.	
2012/0035809	A1	2/2012	Kosaka	
2012/0205176	A1*	8/2012	Ha et al.	180/220
2012/0239284	A1*	9/2012	Field et al.	701/124
2012/0290162	A1*	11/2012	Stevens et al.	701/22
2013/0032422	A1*	2/2013	Chen	180/218
2013/0032423	A1*	2/2013	Chen	180/218
2013/0105239	A1*	5/2013	Fung	180/218
2013/0228385	A1*	9/2013	Chen	180/6.5

(56) **References Cited**

U.S. PATENT DOCUMENTS

6,367,817	B1	4/2002	Kamen et al.	
6,538,411	B1	3/2003	Field et al.	
6,581,714	B1	6/2003	Kamen et al.	
6,651,763	B1	11/2003	Kamen et al.	
6,845,829	B2	1/2005	Hafendorfer	
6,920,947	B2	7/2005	Kamen et al.	
7,023,330	B2	4/2006	Kamen et al.	
7,083,178	B2	8/2006	Potter	
7,090,040	B2	8/2006	Kamen et al.	
7,195,259	B2	3/2007	Gang	
7,275,607	B2	10/2007	Kamen et al.	
7,338,056	B2	3/2008	Chen	
7,363,993	B2	4/2008	Ishii	
7,367,572	B2	5/2008	Jiang	
7,467,681	B2	12/2008	Hiramatsu	
7,479,872	B2	1/2009	Kamen et al.	
7,481,291	B2	1/2009	Nishikawa	
D601,922	S *	10/2009	Imai et al.	D12/1
7,597,334	B2	10/2009	Chen	
7,740,099	B2	6/2010	Field et al.	
7,775,534	B2	8/2010	Chen et al.	
7,783,392	B2	8/2010	Oikawa	
7,857,088	B2	12/2010	Field et al.	
7,958,956	B2	6/2011	Kakinuma et al.	
8,014,923	B2	9/2011	Ishii et al.	
8,028,777	B2	10/2011	Kakinuma et al.	
8,047,556	B2	11/2011	Jang et al.	
8,113,524	B2	2/2012	Karpman	
8,157,274	B2	4/2012	Chen	
8,170,780	B2	5/2012	Field et al.	
8,225,891	B2*	7/2012	Takenaka et al.	180/7.1
8,408,565	B2	4/2013	An	
8,459,668	B2	6/2013	Yoon	
8,467,941	B2	6/2013	Field et al.	
8,490,723	B2	7/2013	Heinzmann et al.	
8,606,468	B2	12/2013	Kosaka	
8,738,278	B2	5/2014	Chen	
8,978,791	B2	3/2015	Ha et al.	
2003/0155167	A1*	8/2003	Kamen	A63C 17/12 180/272
2004/0005958	A1*	1/2004	Kamen et al.	482/51
2004/0262871	A1*	12/2004	Schreuder et al.	280/87.1
2006/0202439	A1*	9/2006	Kahlert et al.	280/47.24
2006/0260857	A1	11/2006	Kakinuma et al.	
2007/0273118	A1	11/2007	Conrad	
2008/0029985	A1*	2/2008	Chen	280/87.042
2008/0147281	A1*	6/2008	Ishii et al.	701/49
2009/0032323	A1*	2/2009	Kakinuma et al.	180/218
2009/0078485	A1*	3/2009	Gutsch et al.	180/218
2009/0105908	A1*	4/2009	Casey et al.	701/41
2009/0115149	A1	5/2009	Wallis et al.	
2009/0200746	A1	8/2009	Yamamoto	
2009/0315293	A1	12/2009	Kosaka	
2010/0025139	A1*	2/2010	Kosaka et al.	180/218
2010/0114468	A1*	5/2010	Field et al.	701/124
2010/0121538	A1*	5/2010	Ishii et al.	701/48
2010/0222994	A1*	9/2010	Field et al.	701/124

FOREIGN PATENT DOCUMENTS

CN	101309730	A	11/2008
CN	101353070	A	1/2009
CN	201205442	Y	3/2009
CN	101444667	A	6/2009
CN	101513569		8/2009
CN	201283206	Y	8/2009
CN	201350326	Y	11/2009
CN	20142315	Y	3/2010
CN	201419008	Y	3/2010
CN	201431762	Y	3/2010
CN	101920728		12/2010
CN	101920728	A	12/2010
CN	101939065	A	1/2011
CN	102089200	A	6/2011
CN	101513569	B	7/2011
CN	301604610	S	7/2011
CN	201978449	U	9/2011
CN	202201103	U	4/2012
CN	10251663	B	6/2012
CN	102514662	A	6/2012
CN	102514662	B	6/2012
CN	102514663	A	6/2012
CN	102602481	A	7/2012
CN	102616310	A	8/2012
EP	1791609	B1	11/2011
JP	2001178863	A	7/2001
JP	2004359094	A	12/2004
JP	200594898	A	4/2005
JP	2005094898		4/2005
JP	2005094898	A	4/2005
JP	2005335471	A	12/2005
JP	2006001384	A	1/2006
JP	2006001385	A	1/2006
JP	2006008013	A	1/2006
JP	3981733	A	9/2007
JP	2010030436	A	2/2010
JP	2010030437	A	2/2010
JP	2010030438	A	2/2010
JP	2010030568	A	2/2010
JP	2010030569	A	2/2010
JP	2010035330	A	2/2010
JP	2011131620	A	7/2011

OTHER PUBLICATIONS

Administrative Judgment, Beijing Intellectual Property Court of the People's Republic of China, dated Jan. 16, 2018, 10 pages.
 Exhibit 11 from co-pending Chinese litigation for rejected Application No. CN201210112847.X (CN102602481), including Office Actions from the Examiner, dated Oct. 20, 2016, 81 pages.
 Appellants' (Razor USA LLC, Inventist, Inc. and Shane Chen), Non-Confidential Brief, Appeal from ITC Case No. 337-TA-1000, U.S. Court of Appeals for the Federal Circuit No. 17-2591, Jan. 8, 2018, 174 pages. [Divided Into 4 Parts].
 Kim et al., Development of a Two-Wheeled Mobile Tilting & Balancing (MTB) Robot, 2011 11th International Conference on Control, Automation and Systems (ICCAS), Gyeonggi-do, 2011, pp. 1-6.

(56)

References Cited

OTHER PUBLICATIONS

- Clark, et al. "Edgar, A Self-Balancing Scooter Final Report" (2005). (Divided in to 2 parts for submission).
- Li et al., A coaxial couple wheeled equilibrium robot with T-S fuzzy equilibrium control, *Industrial Robot: An International Journal*, vol. 38, Issue 3, pp. 202-300, 2011.
- Complainants' (Razor USA LLC, Inventist, Inc., and Shane Chen), Documents in Support of Request to commence an investigation, ITC Case No. 337-TA-1000, Exhibit 1010, Mar. 21, 2016, pp. 1-132. [References split in to 6 parts].
- Declaration of Dr. Gerald Cook, Exhibit 1008, Inter Partes Review No. 2016-01778, Sep. 13, 2016, pp. 1-98.
- Respondents' (Hangzhou Chic Intelligent Technology Co., Ltd, Swagway, LLC, Modell's Sporting Goods, Inc., Newegg, Inc., Powerboard a.k.a. Optimum Trading Co., United Integral, Inc. dba Skque Products, Alibaba Group Holding Ltd. and Alibaba.com Ltd., and Jetson Electric Bikes LLC) Opening Claim Construction Brief, ITC Case No. 337-TA-1000, Aug. 19, 2016, pp. 1-229 [References split in to 4 parts].
- Contingent Petition for Review of Initial Determination by Respondents Swagway, LLC, Modell's Sporting Goods, Inc., and Newegg, Inc., ITC Case No. 337-TA-1000, Jun. 12, 2017, pp. 1-39.
- Quick, Darren, Nissan Joins Personal Mobility Field with "Segway-skis", <http://www.gizmag.com/nissan-personal-mobility-device/13210/>, New Atlas, Urban Transport, Oct. 27, 2009, pp. 1-9.
- Decision Denying Institution of Inter Partes Review under 37 C.F.R. 42.108, Petravick et al., Administrative Patent Judges, Inter Partes Review No. IPR2016-01778, Mar. 16, 2017, pp. 1-20.
- Quick, Darren, Nissan joins personal mobility field with Segway-skis, www.gizmag.com, Oct. 27, 2009.
- Sasaki, Makiko, et al., Steering Control of the Personal Riding type Wheeled Mobile Platform (PMP), 2005 IEEE, International Conference on Intelligent Robots and Systems, Aug. 2005, pp. 54-60.
- Hornyak, Tim, Robot roller skates less bulky than Segway, www.cnet.com, Nov. 27, 2009.
- Initial Determination on Violation of Section 337 and Recommended Determination on Remedy and Bond, ITC Case No. 337-TA-1000, May 26, 2017, pp. 1-93.
- Declaration of W. Mark Richter in Support of Patent Owner Preliminary Response, Inter Partes Review No. IPR2016-01778, Dec. 27, 2016, pp. 1-8.
- Complainants' (Razor USA LLC, Inventist, Inc., and Shane Chen), Documents in Support of Request to commence an investigation, ITC Case No. 337-TA-1000, Exhibit 1010, Mar. 21, 2016, pp. 1-132.
- Declaration of Dr. Gerald Cook, Exhibit 1008, Inter Partes Review No. IPR2016-01778, Sep. 13, 2016, pp. 1-98.
- Complainants' (Razor USA LLC, Inventist, Inc., and Shane Chen) Initial Claim Construction Brief, ITC Case No. 337-TA-1000, Aug. 19, 2016, pp. 1-217.
- Respondents' (Hangzhou Chic Intelligent Technology Co., Ltd, Swagway, LLC, Modell's Sporting Goods, Inc., Newegg, Inc., Powerboard a.k.a. Optimum Trading Co., United Integral, Inc. dba Skque Products, Alibaba Group Holding Ltd. and Alibaba.com Ltd., and Jetson Electric Bikes LLC) Opening Claim Construction Brief, ITC Case No. 337-TA-1000, Aug. 19, 2016, pp. 1-229.
- Claim Construction Brief of The Commission Investigative Staff, ITC Case No. 337-TA-1000, Aug. 29, 2016, pp. 1-26.
- Complainants' (Razor USA LLC, Inventist, Inc., and Shane Chen) Rebuttal Claim Construction Brief, ITC Case No. 337-TA-1000, Sep. 2, 2016, pp. 1-24.
- Respondents' (Hangzhou Chic Intelligent Technology Co., Ltd, Swagway, LLC, Modell's Sporting Goods, Inc., Newegg, Inc., Powerboard a.k.a. Optimum Trading Co., United Integral, Inc. dba Skque Products, Alibaba Group Holding Ltd. and Alibaba.com Ltd., and Jetson Electric Bikes LLC) Rebuttal Claim Construction Brief, ITC Case No. 337-TA-1000, Sep. 2, 2016, pp. 1-48.
- Notice of Institution of Investigation, ITC Case No. 337-TA-1000, May 20, 2016, pp. 1-48.
- Patent Owner Preliminary Response, Inter Partes Review No. IPR2016-01778, Dec. 27, 2016, pp. 1-51.
- Complainants' (Razor USA LLC, Inventist, Inc., and Shane Chen) Petition for Review, ITC Case No. 337-TA-1000, Jun. 12, 2017, pp. 1-40.
- Contingent Petition for Review of Initial Determination by Respondents Swagway, LLC, Modell's Sporting Goods, Inc., and Newegg, Inc., ITC Case No. 337-TA-1000, Jun. 12, 2017, pp. 1-39.
- Respondent Hangzhou Chic Intelligent Technology Co., Ltd's Contingent Petition for Review, ITC Case No. 337-TA-1000, Jun. 12, 2017, pp. 1-22.
- Petition of the Office of Unfair Import Investigations for Review In-Part of the Initial Determination on Violation, ITC Case No. 337-TA-1000, Jun. 12, 2017, pp. 1-28.
- Jetson's Opposition to Petitions Filed by the ITC Attorney and Razor, ITC Case No. 337-TA-1000, Jun. 20, 2017, pp. 1-16.
- Complainants' Opposition to Respondents' Contingent Petitions for Review Filed By (1) Hangzhou Chic Intelligent Co., Ltd., and (2) Respondents Swagway, LLC, Modell's Sporting Goods, Inc., and Newegg, Inc., ITC Case No. 337-TA-1000, Jun. 20, 2017, pp. 1-62.
- Combined Response of the Office of Unfair Import Investigations to Complainants' Petition for Review and Respondents' Contingent Petitions For Review of the Initial Determination on Violation, ITC Case No. 337-TA-1000, Jun. 20, 2017, pp. 1-48.
- Response to Complainants' and Staff's Petitions for Review of Initial Determination by Respondents Swagway, LLC, Modell's Sporting Goods, Inc., Hangzhou Chic Intelligent Technology Co., Ltd., and Newegg.com, Inc., ITC Case No. 337-TA-1000, Jun. 20, 2017, pp. 1-34.
- Alibaba's Response to the Petitions for Review, ITC Case No. 337-TA-1000, Jun. 20, 2017, pp. 1-7.
- Order 25: Construing the Terms of the Asserted Claims of the Patent at Issue, ITC Case No. 337-TA-1000, Nov. 1, 2016, pp. 1-26.
- Consolidated Initial Proposed Claim Constructions, ITC Case No. 337-TA-1000, Jul. 19, 2016, pp. 1-8.
- Respondents Powerboard LLC's and Jetson Electric Bikes, LLC's Motion for Summary Determination of Non-Infringement, ITC Case No. 337-TA-1000, Dec. 12, 2016, pp. 1-30.
- Respondent Hangzhou Chic Intelligent Technology Co., Ltd.'s Objections and Responses to Complainants' First Set of Contention Interrogatories, ITC Case No. 337-TA-1000, Sep. 9, 2016, pp. 1-208.
- Petition for Inter Partes Review of U.S. Pat. No. 8,738,278, Inter Partes Review No. IPR2016-01778, Sep. 13, 2016, pp. 1-73.
- Steering Control of the Personal Riding-type Wheeled Mobile Platform (PMP) Edmonton, AB, Canada (Sasaki) 2005.
- "More Weird Ways to Skate the Streets" (Tran), Sep. 7, 2007.
- Personal Mobility Robot, Mar. 2011.
- "Getting Started Manual, Segway Personal Transporter (PT) i2, x2" (Segway Manual) 2006.
- Razor USA LLC and Shane Chen*, Plaintiffs. v. *DGL Group, Ltd.*, Defendant; Defendant DGL Group, Ltd.'s Second Amended Invalidity Contentions, Case No. 2:19-cv-12939-JMV-MF.
- Razor USA LLC and Shane Chen*, Plaintiffs. v. *DGL Group, Ltd.*, Defendant; Defendant DGL Group, Ltd.'s Second Amended Invalidity Contentions, Case No. 2:19-cv-12939-JMV-MF; Exhibit AA (Claim Chart for U.S. Pat. No. 6,845,829).
- Razor USA LLC and Shane Chen*, Plaintiffs. v. *DGL Group, Ltd.*, Defendant; Defendant DGL Group, Ltd.'s Second Amended Invalidity Contentions, Case No. 2:19-cv-12939-JMV-MF; Exhibit BB (Claim Chart for U.S. Pat. No. 5,131,875).
- Razor USA LLC and Shane Chen*, Plaintiffs. v. *DGL Group, Ltd.*, Defendant; Defendant DGL Group, Ltd.'s Second Amended Invalidity Contentions, Case No. 2:19-cv-12939-JMV-MF; DGL Defendant's Disclosure of Invalidity Contentions Pursuant to Patent Local Rule 3.3 U.S. Pat. No. RE. 46,964 Exhibit E, Sasaki-Steering Control of the Personal Riding-type Wheeled Mobile Platform (PMP) Published: 2005.
- Razor USA LLC and Shane Chen*, Plaintiffs. v. *DGL Group, Ltd.*, Defendant; Defendant DGL Group, Ltd.'s Second Amended Invalidity Contentions, Case No. 2:19-cv-12939-JMV-MF; Amended Exhibit I—JP 2005-94898 A, Published: Apr. 7, 2005.

(56)

References Cited

OTHER PUBLICATIONS

Razor USA LLC and Shane Chen, Plaintiffs. v. *DGL Group, Ltd.*, Defendant; Defendant DGL Group, Ltd.'s Second Amended Invalidation Contentions, Case No. 2:19-cv-12939-JMV-MF; Exhibit Y (Claim Chart for U.S. Pat. No. 6,302,230).

Razor USA LLC and Shane Chen, Plaintiffs. v. *DGL Group, Ltd.*, Defendant; Defendant DGL Group, Ltd.'s Second Amended Invalidation Contentions, Case No. 2:19-cv-12939-JMV-MF; Exhibit Z—"Getting Started Manual, Segway Personal Transporter (PT) i2, x2" (Segway Manual).

Kim, Sangtae et al., Development of a Two-Wheeled Mobile Tilting & Balancing (MTB) Robot, 11th International Conference on Control, Automation and Systems (ICCAS), Oct. 26-29, 2011, pp. 1-6, Kintex, Gyeonggi-do, Korea.

Quirk, Trevor, "Why you shouldn't expect a hoverboard any time soon," *Christian Science Monitor*, URL=<https://www.csmonitor.com/Science/2012/0213/Why-you-shouldn-t-expect-a-hoverboard-any-time-soon>, Feb. 13, 2012, Web. Jul. 5, 2016, pp. 1-5.

Quick, Darren, Nissan Joins Personal Mobility Field with "Segway-skis", <http://www.gizmag.com/nissan-personal-mobility-device/13210/>, *New Atlas, Urban Transport*, Oct. 27, 2009, pp. 1-9.

Bash, John D., "How Do Self Balancing Scooters Work?" URL=<https://bestelectrichoverboard.com/hoverboard-faq/how-do-self-balancing-scooters-work/>, Exhibit 2012, Inter Partes Review No. IPR2016-01778, Nov. 12, 2015, Web. Oct. 8, 2016, pp. 1-7.

Wells, Georgia, "What It's Like to Have Wheels for Feet: Test Driving the Latest 'Hoverboards,'" *The Wall Street Journal*, URL=<https://www.wsj.com/articles/what-its-like-to-have-wheels-for-feet-test-driving-the-latest-hoverboards-1446055640>, Exhibit 2011, Oct. 28, 2015, Web. Oct. 8, 2016, Inter Partes Review No. IPR2016-01778, pp. 1-5.

Google Trends—Web Search Interest: hoverboard—United States, Jan. 2004-Jul. 2016, Jul. 5, 2016, Exhibit 2010, Inter Partes Review No. IPR2016-01778, pp. 1-6.

Banks, Alec, "Everything You Need to Know About the 'Hoverboard' Craze," URL=<http://www.highsnobiety.com/2015/10/14/hoverboard-history/>, Exhibit 2004, Inter Partes Review No. IPR2016-01778, Oct. 14, 2015, Web. Jul. 25, 2016, pp. 1-13.

Detrick, Ben, "Celebrities on Scooters (Catch Them if You Can)," *The New York Times*, URL=<https://www.nytimes.com/2015/08/16/fashion/cara-delevingne-justin-bieber-meek-mill-stephen-curry-on-scooters.html>, Exhibit 2005, Inter Partes Review No. IPR2016-01778, Aug. 15, 2015, Web. Jul. 25, 2016, pp. 1-6.

Murphy, Mike, "Everything you've ever wanted to know about the hoverboard craze," *Quartz*, URL=<https://qz.com/495935/everything-youve-ever-wanted-to-know-about-the-hoverboard-craze/>, Exhibit 2006, Inter Partes Review No. IPR2016-01778, Nov. 11, 2015, Web. Jul. 25, 2016, pp. 1-12.

Kantrowitz, Alex, Everything You Need to Know About The Hoverboard Craze, *BuzzFeed News*, URL=https://www.buzzfeed.com/alexkantrowitz/a-crash-course-in-hoverboards?utm_term=.qwV3MnB77#.debmbaMjj, Exhibit 2007, Inter Partes Review No. IPR2016-01778, Aug. 27, 2015, Web. Dec. 26, 2016, pp. 1-9.

Hoverguru, <http://hoverguru.com/>, "'They're completely different products': IO HAWK President John Soibatian not concerned about infringing on Hovertrax patent," URL=<http://hoverguru.com/posts/theyre-completely-different-products-io-hawk-president-john-soibatian-not-concerned-about-infringing-on-hovertrax-patent/>, Exhibit 2008, Inter Partes Review No. IPR2016-01778, Aug. 31, 2015, pp. 1-5.

Robinson, Mandy, "Hoverboard Black Friday Sales: Best Places to Get One Before Christmas," URL=<https://www.inquisitr.com/2589773/hoverboard-black-friday-sales-best-places-to-get-one-before-christmas/>, *Gadgets, INQUISITR.com*, Exhibit 2009, Inter Partes Review No. IPR2016-01778, Nov. 24, 2015, Web. Jul. 27, 2016, pp. 1-8.

U.S. Appl. No. 61/597,777, filed Feb. 12, 2012, Applicant: Shane Chen, 8 pages.

Abeygunawardhana et al., Vibration Suppression of Two-Wheel Mobile Manipulator Using Resonance-Ratio-Control-Based Null-Space Control, *IEEE Transactions on Industrial Electronics*, vol. 57, No. 12, pp. 4137-4146 (2010).

Kim et al., Development of a Two-Wheeled Mobile Tilting & Balancing (MTB) Robot, 2011 11th International Conference on Control, Automation and Systems (ICCAS), Gyeonggi-do, 2011, pp. 1-6.

Azizan et al., Fuzzy Control Based on LMI Approach and Fuzzy Interpretation of the Rider Input for Two Wheeled Balancing Human Transporter, 2010 8th IEEE International Conference on Control and Automation, Xiamen, 2010, pp. 192-197.

Cardozo et al., Prototype for a Self-Balanced Personal Transporter, 2012 Workshop on Engineering Applications (WEA), Bogota, 2012, pp. 1-6.

Chiu et al., Design and implement of the self-dynamic controller for two-wheel transporter, 2006 IEEE International Conference on Fuzzy Systems, Vancouver, BC, 2006, pp. 480-483.

Tsai et al., Intelligent Adaptive Motion Control Using Fuzzy Basis Function Networks for Self-Balancing Two-Wheeled Transporters, 2010 IEEE Conference on Fuzzy Systems, Barcelona, 2010 pp. 1-6.

Choi et al., Four and Two Wheel Transformable Dynamic Mobile Platform, 2011 IEEE International Conference on Robotics and Automation (ICRA), Shanghai, pp. 1-4.

Clark, et al. "Edgar, A Self-Balancing Scooter Final Report" (2005).

Coelho et al., Development of a Mobile Two-Wheel Balancing Platform for Autonomous Applications, 15th International Conference on Mechatronics and Machine Vision in Practice, Auckland, 2008, pp. 575-580.

Rebuttal Expert Report of William Singhose, Ph.D., on Claim Construction Issues (dated Aug. 10, 2016), including all attachments thereto and exhibits thereto.

Sasaki et al., Forward and Backward Motion Control of Personal Riding-type Wheeled Mobile Platform, Proceedings of the 2004 IEEE International Conference on Robotics and Automation, vol. 4, pp. 3331-3336.

Li et al., A coaxial couple wheeled equilibrium robot with T-S fuzzy equilibrium control, *Industrial Robot: An International Journal*, vol. 38, Issue 3, pp. 292-300, 2011.

Li et al., Controller Design of a Two-Wheeled Inverted Pendulum Mobile Robot, 2008 IEEE International Conference on Mechatronics and Automation, Takamatsu, pp. 7-12.

Seo et al., Simulation of Attitude Control of a Wheeled Inverted Pendulum, *International Conference on Control, Automation, and Systems*, 2007, Seoul, pp. 2264-2269.

Li et al., Mechanical Design and Dynamic Modeling of a Two-Wheeled Inverted Pendulum Mobile Robot, Proceedings of the 2007 IEEE International Conference on Automation and Logistics, Jinan, 2007, pp. 1614-1619.

Lin et al., Adaptive Robust Self-Balancing and Steering of a Two-Wheeled Human Transportation Vehicle, *62 J Intell Robot Syst*, pp. 103-123 (2011) (first published online Aug. 27, 2010).

Decision Denying Institution of Inter Partes Review under 37 C.F.R. 42.108, Petravick et al., Administrative Patent Judges, Inter Partes Review No. IPR2016-01778, Mar. 16, 2017, pp. 1-20.

Sasaki, Makiko et al., Steering Control of the Personal Riding-type Wheeled Mobile Platform (PMP), IEEE, International Conference on Intelligent Robots and Systems, Dec. 5, 2005, pp. 3821-3826, Edmonton, Alberta, Canada.

Razor USA LLC and Shane Chen, Plaintiffs. v. *DGL Group, Ltd.*, Defendant; Defendant DGL Group, Ltd.'s Notice of Unopposed Motion for Leave to Amend its Second Amended Non-Infringement Contentions, Case No. 2:19-cv-12939-JMV-AME.

Razor USA LLC and Shane Chen, Plaintiffs. v. *DGL Group, Ltd.*, Defendant; Plaintiff's Motion for Leave to Amend Their Fourth Amended Infringement Contentions; Case No. 2:19-cv-12939-JMV-AME.

Razor USA LLC and Shane Chen, Plaintiffs. v. *DGL Group, Ltd.*, Defendant; Memorandum in Support of Plaintiff's Motion for Leave to Amend Their Fourth Amended Infringement Contentions; Case No. 2:19-cv-12939-JMV-AME.

Razor USA LLC and Shane Chen, Plaintiffs. v. *DGL Group, Ltd.*, Defendant; Declaration of Benjamin A. Katzenellenbogen in Sup-

(56)

References Cited

OTHER PUBLICATIONS

port of Plaintiffs Motion for Leave to Amend Their Fourth Amended Infringement Contentions; Case No. 2:19-cv-12939-JMV-AME.

Razor USA LLC and Shane Chen, Plaintiffs. v. *DGL Group, Ltd.*, Defendant; Defendant DGL Group Ltd.'s Brief in Opposition to Plaintiff's Motion for Leave to Amend Their Fourth Amended Infringement Contentions; Case No. 2:19-cv-12939-JMV-AME.

Razor USA LLC and Shane Chen, Plaintiffs. v. *DGL Group, Ltd.*, Defendant; Notice of Motion to Stay, Oral Argument Requested [L.Civ.R. 78.1]; Case No. 2:19-cv-12939-JMV-AME.

Razor USA LLC and Shane Chen, Plaintiffs. v. *DGL Group, Ltd.*, Defendant; Brief in Support of Motion to Stay, Oral Argument Requested [L.Civ.R. 78.1]; Case No. 2:19-cv-12939-JMV-AME.

Razor USA LLC and Shane Chen, Plaintiffs. v. *DGL Group, Ltd.*, Defendant; Declaration of Bryan J. Jaketic in Support of Defendant DGL Group Ltd.'s Opposition to Plaintiff's Motion for Leave to Amend Their Fourth Amended Infringement Contentions; Case No. 2:19-cv-12939-JMV-AME, with Exhibits (Part 1 of 4).

Razor USA LLC and Shane Chen, Plaintiffs. v. *DGL Group, Ltd.*, Defendant; Declaration of Steven M. Auvil in Support of Motion to Stay; Case No. 2:19-cv-12939-JMV-AME, with Exhibits (Part 2 of 4).

Razor USA LLC and Shane Chen, Plaintiffs. v. *DGL Group, Ltd.*, Defendant; Declaration of Steven M. Auvil in Support of Motion to Stay; Case No. 2:19-cv-12939-JMV-AME, with Exhibits (Part 3 of 4).

Razor USA LLC and Shane Chen, Plaintiffs. v. *DGL Group, Ltd.*, Defendant; Declaration of Steven M. Auvil in Support of Motion to Stay; Case No. 2:19-cv-12939-JMV-AME, with Exhibits (Part 4 of 4).

Razor USA LLC and Shane Chen, Plaintiffs. v. *DGL Group, Ltd.*, Defendant; Declaration of Bryan J. Jaketic in Support of Defendant DGL Group Ltd.'s Opposition to Plaintiff's Motion for Leave to Amend Their Fourth Amended Infringement Contentions; Case No. 2:19-cv-12939-JMV-AME, with Exhibits (Part 2 of 4).

Razor USA LLC and Shane Chen, Plaintiffs. v. *DGL Group, Ltd.*, Defendant; Declaration of Bryan J. Jaketic in Support of Defendant DGL Group Ltd.'s Opposition to Plaintiff's Motion for Leave to Amend Their Fourth Amended Infringement Contentions; Case No. 2:19-cv-12939-JMV-AME, with Exhibits (Part 3 of 4).

Razor USA LLC and Shane Chen, Plaintiffs. v. *DGL Group, Ltd.*, Defendant; Declaration of Bryan J. Jaketic in Support of Defendant DGL Group Ltd.'s Opposition to Plaintiff's Motion for Leave to Amend Their Fourth Amended Infringement Contentions; Case No. 2:19-cv-12939-JMV-AME, with Exhibits (Part 4 of 4).

Razor USA LLC and Shane Chen, Plaintiffs. v. *DGL Group, Ltd.*, Defendant; Declaration of Steven M. Auvil in Support of Motion to Stay; Case No. 2:19-cv-12939-JMV-AME, with Exhibits (Part 1 of 4).

Razor USA LLC and Shane Chen, Plaintiffs. v. *DGL Group, Ltd.*, Defendant; Declaration of Steven M. Auvil in Support of Motion to Stay; Case No. 2:19-cv-12939-JMV-AME, with Exhibits (Part 2 of 4).

Razor USA LLC and Shane Chen, Plaintiffs. v. *DGL Group, Ltd.*, Defendant; Declaration of Steven M. Auvil in Support of Motion to Stay; Case No. 2:19-cv-12939-JMV-AME, with Exhibits (Part 3 of 4).

Razor USA LLC and Shane Chen, Plaintiffs. v. *DGL Group, Ltd.*, Defendant; Declaration of Steven M. Auvil in Support of Motion to Stay; Case No. 2:19-cv-12939-JMV-AME, with Exhibits (Part 4 of 4).

* cited by examiner

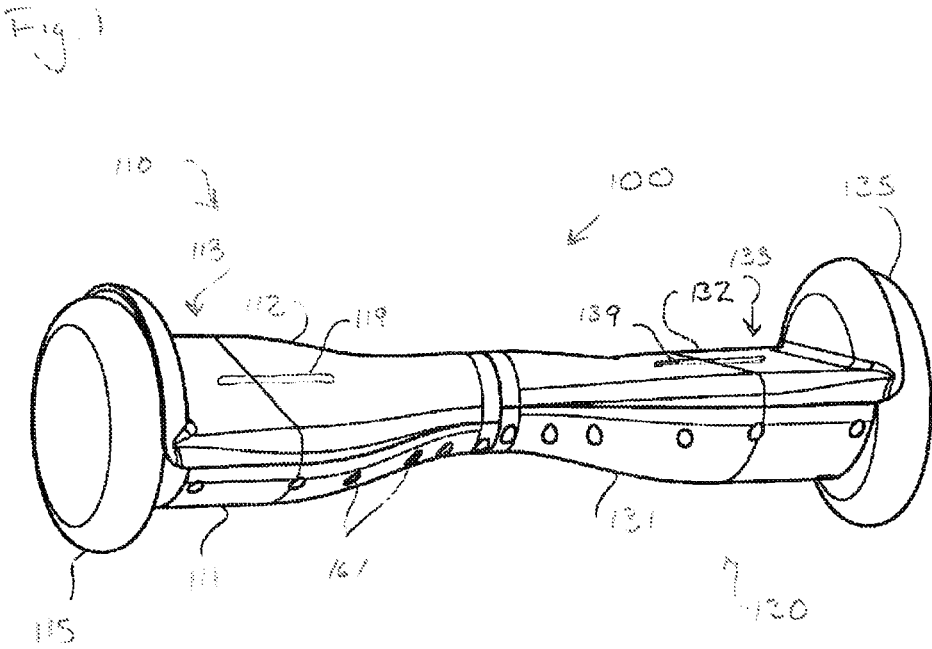

Fig. 2

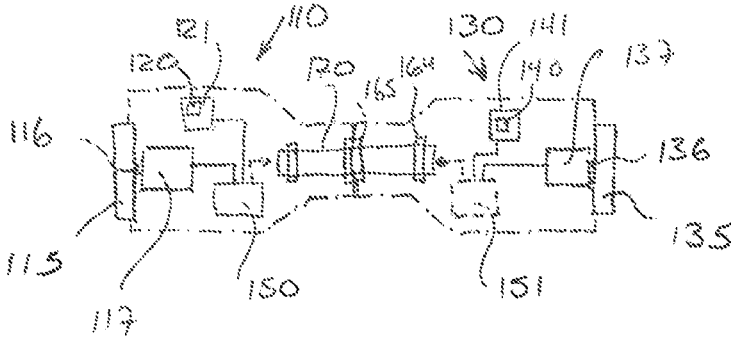

Fig 3

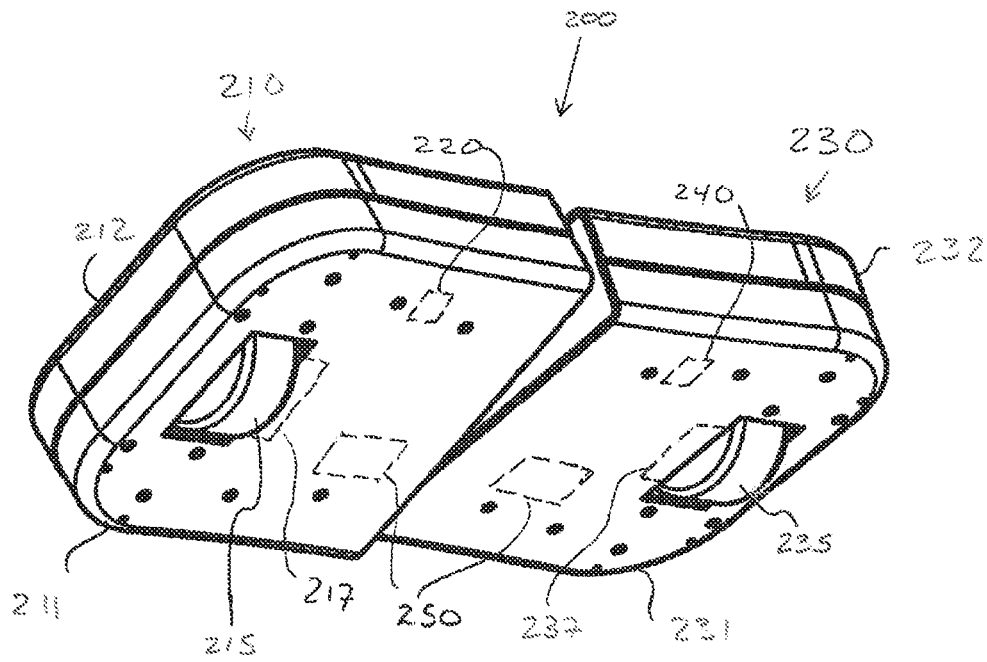

Fig 4

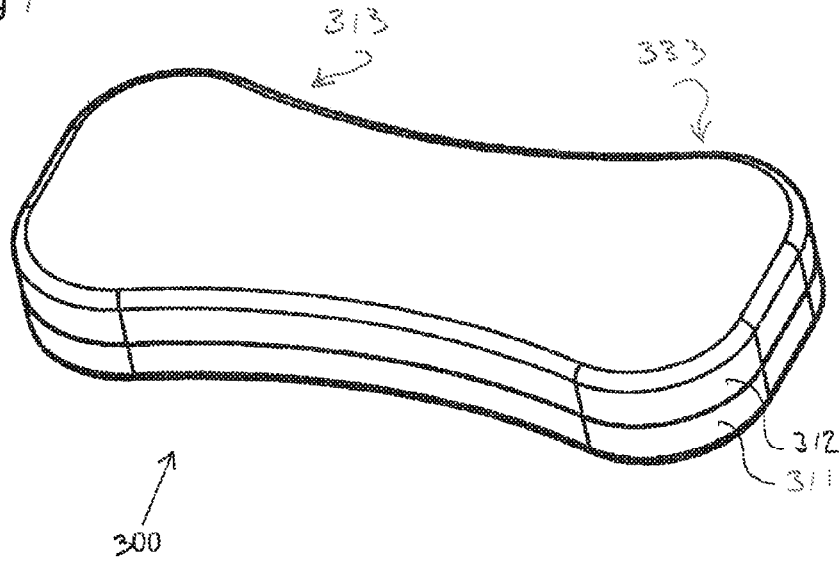
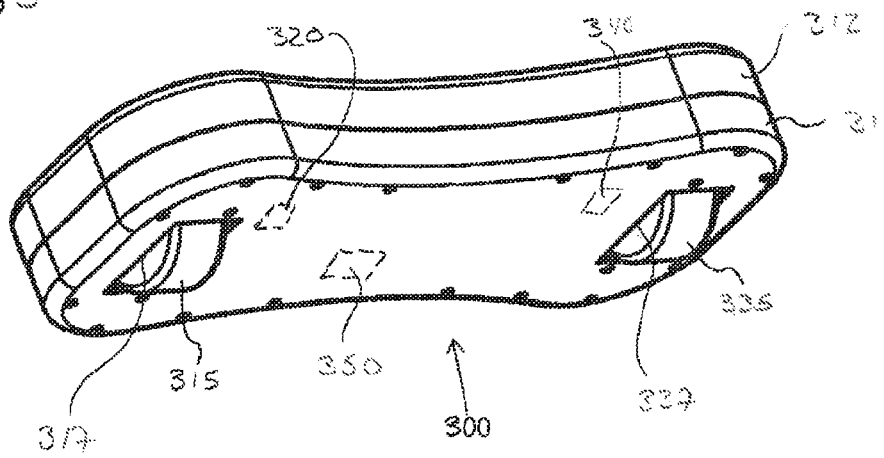

Fig 5



TWO-WHEEL SELF-BALANCING VEHICLE WITH INDEPENDENTLY MOVABLE FOOT PLACEMENT SECTIONS

Matter enclosed in heavy brackets [] appears in the original patent but forms no part of this reissue specification; matter printed in italics indicates the additions made by reissue; a claim printed with strikethrough indicates that the claim was canceled, disclaimed, or held invalid by a prior post-patent action or proceeding.

CROSS REFERENCE TO RELATED APPLICATIONS

[The present application] *This is an application for reissue of U.S. Pat. No. 8,738,278. This application claims benefit under 35 U.S.C. 120 as a continuation of application Ser. No. 15/165,654, which is an application for reissue of U.S. Pat. No. 8,738,278. Each of the aforementioned patent and applications claims the benefit of provisional application No. 61/597,777, filed Feb. 12, 2012, for a Two-Wheeled Self-Balancing Vehicle by the inventor herein.*

FIELD OF THE INVENTION

The present invention relates to two-wheel, self-balancing vehicles and, more specifically, to such vehicles with two platform sections or areas that are independently movable with respect to one another and that thereby provide independent control and/or drive of the wheel associated with the given platform section/area.

BACKGROUND OF THE INVENTION

A first group of prior art two-wheel self-balancing vehicles is represented by a product known commonly as the "Segway." This product is disclosed in U.S. Pat. No. 6,302,230, issued to Sramek et al (the '230 patent). While a contribution in the field, the Segway and like devices are disadvantageous in that they are large, heavy and expensive, i.e., too heavy to be carried by a commuter or youth, too expensive for most to buy. Furthermore, turning is achieved through a handle bar structure that ascends from the platform upward toward the chest of a user. This tall steering structure is a trip hazard when a user makes an unplanned exit from the vehicle.

Another group of prior art two-wheel self-balancing vehicles has two platform sections, each associated with a given wheel, that tilt from side-to-side as a user leans left or right. The two platform sections move in a linked or "dependent" manner (for example, through a parallelogram frame, and not independently) and there is a single "vertical" axis for the platforms. When the axis is tilted directly forward or backward, both wheels drive at the same speed (as required for self-balancing). If a user leans to the side (tilts the "vertical" axis sideways), then the outside wheel is driven faster than the inside wheel to effect a turn toward the direction of the tilt.

These devices typically require a multi-component parallelogram structure to coordinate/link movement of the two platform sections and the wheels. Such componentry adds to the weight, bulk, complexity, and potential for mechanical failure of the device. Also, the turning radius is fairly large as one wheel is typically rotating around the other (moving in the same direction though at different speeds).

A need exists for a two-wheel self-balancing vehicle that provides independent wheel control, is light-weight and compact, is easy and safe to use, and that may be made in a cost-effective manner. A need also exists for a two-wheel self-balancing vehicle that is more maneuverable and more ergonomic (functioning more naturally with the bio-mechanics of a user's legs and body) than prior art devices.

Other prior art includes skateboards that have two platform sections that are movable with respect to one another. Some have a shared shaft about which the two platform sections pivot, while others have a degree of flexibility in the platform. In both of these arrangements, the platform sections are arranged longitudinally, one primarily behind the other in the longitudinal line-of-direction of travel.

SUMMARY OF THE INVENTION

Accordingly, it is an object of the present invention to provide a two-wheel, self-balancing vehicle that overcomes the shortcomings of the prior art.

It is another object of the present invention to provide a two-wheel, self-balancing vehicle that has independently movable foot placement sections.

It is also an object of the present invention to provide such a two-wheel, self-balancing vehicle in which the independently movable foot placement sections are used by an operator to assert independent control over the driving of the wheel associated with the respective foot placement section. These and related objects of the present invention are achieved by use of a two-wheel, self-balancing vehicle with independently movable foot placement sections as described herein.

The attainment of the foregoing and related advantages and features of the invention should be more readily apparent to those skilled in the art, after review of the following more detailed description of the invention taken together with the drawings.

BRIEF DESCRIPTION OF THE DRAWINGS

FIG. 1 is a perspective view of a two-wheel, self-balancing vehicle with independently movable platform sections in accordance with the present invention.

FIG. 2 is a block diagram of components within the vehicle of FIG. 1.

FIG. 3 is a bottom perspective view of another embodiment of a two-wheel, self-balancing vehicle with independently movable platform sections in accordance with the present invention.

FIGS. 4-5 are a top perspective view and a bottom perspective view of another embodiment of a two-wheel, self-balancing vehicle with independently movable platform sections in accordance with the present invention.

DETAILED DESCRIPTION

Referring to FIG. 1, is a perspective view of a two-wheel, self-balancing vehicle **100** with independently movable platform sections in accordance with the present invention is shown.

Vehicle **100** may have a first and a second platform section **110,130**. Each platform section **110,130** may include a housing formed of a bottom housing member **111,131** and a top housing member **112,132**. The top housing members may have a foot placement section or area **113,133** formed integrally therewith or affixed thereon. The foot placement

section is preferably of sufficient size to receive the foot of a user and may include a tread or the like for traction and/or comfort.

The housing may be formed of metal, sturdy plastic or other suitable material. The housing members may be molded and incorporate strengthening reinforcements, and be shaped to receive and “nest” the internal components (discussed below) of the vehicle. The bottom and top housing sections are formed complementarily so that after the internal components are installed, the top housing section is fitted onto the bottom housing section and secured with screws or other fasteners. FIG. 1 illustrates holes 161, through which the fasteners are inserted.

Each platform section includes a wheel 115,135, and each wheel preferably has an axle 116,136 and motorized hub assembly 117,137 (shown in FIG. 2). Motorized hub assemblies are known in the art.

Referring to FIG. 2, a block diagram of components within vehicle 100 in accordance with the invention is shown. The dot-dash line represents a rough outline of the housing members. Each platform section preferably includes a position sensor 120,140, which may be a gyroscopic sensor, for independent measurement of the position of the respective platform section. The sensors are preferably mounted on circuit boards 121,141 that may be attached to the interior of the respective bottom housings. Sensed position information from sensor 120,140 is used to drive the corresponding motor 117,137 and wheel 115,135. The control logic for translating position data to motor drive signals may be centralized or split between the two platform sections. For example, control logic 150 may be electrically connected to sensors 120,140 and to drive motors 117,137, with electrical conduits connecting through the connecting shaft 170 between sensor 140, control logic 150, and drive motor 137.

Alternatively, a separate processor/control logic 151 may be provided in the second platform section 130. Logic 151, in this case, [would be] is [connect] *connected* directly to sensor 140 and drive motor 137 and [generate] *generates* drive signals to motor 137 (and wheel 135) based on data from sensor 140.

Communication between these components is primarily in the direction of data from the sensor and drive signals to the motor. However, communication in the other direction may include start signals ([ie] *i.e.*, to the sensor), status signals ([ie] *i.e.*, from the motor indicating an unsafe condition (e.g., excessive rpm), or a motor/drive failure or irregularity). This information, in addition to battery information, etc., could be communicated back to a user via lights or another interface, or communicated wirelessly (e.g., bluetooth) from the vehicle to a hand-held device such as a mobile phone. In addition, if the platform sections have separate and independent control logic 150,151, these processing units may still share information with one another, such as status, safe operation information, etc.

The two platform sections 110,130 are movably coupled to one another. FIG. 2 illustrates a shaft 170 about which they may rotate (or pivot with respect to one another). Brackets 164 and flange brackets 165 may secure the shaft to the platform sections, with the flange brackets preferably configured to prevent or reduce the entry of dirt or moisture within the housings. Shaft 170 may be hollow in part and thereby allowing for the passage of conduits therethrough. Pivoting or rotating shaft arrangements are known in the art, and others may be used without deviating from the present invention as long as the foot placement sections may move independently.

Since the platform sections may rotate or pivot with respect to one another, the left section 110, for example, may tilt forward while the right section tilts backward. This would cause the wheels to be driven in opposite directions, causing a user to spin-in-place or “pirouette” much like a figure skater. Alternatively, the platform wheels could be tilted in the same direction, but one platform more than the other. This would cause the wheel associated with the more steeply tilted platform to drive faster, in turn causing the vehicle to turn. The sharpness of the turn could be readily adjusted by the user based on the relative tilt of the platform sections.

This leg movement to control turning is a very ergonomic and natural movement, akin to skiing and other gliding/sliding activities.

The rotating shaft 170 may also include a bias mechanism integral with the flange bracket 165 or otherwise configured to return the platform section to an even level in the absence of displacement from a riders weight.

Each platform section 110,130 may also include a platform or “shut-off” sensor 119,139 that detects when a user is standing [of] on the platform. When a user falls off, the absence of the rider is sensed and the control logic, in response, stops driving the wheels such that the vehicle comes to a stop (and does not carry on [rider less] *riderless*). In the absence of such a shut-off sensor, the vehicle would still stop rather soon as the wheels will be driven to a self-balancing position for their respective sections bringing the device to rest.

Referring to FIG. 3, a bottom perspective view of another embodiment of a two-wheel, self-balancing vehicle 200 with independently movable platform sections in accordance with the present invention is shown. Vehicle 200 may include first and second platform section 210,230 that are formed of bottom 211,231 and top 212,232 housing sections, similar to those in vehicle 100 above.

Each platform section 110,130 includes a wheel 215,235 which is respectively driven by a motorized hub 217,237 and an associated position sensor 220,240. Control logic 250 receives the sensed position information and drives the associated wheel toward self-balancing. As discussed above, the control logic 250 may be independent, provided in each platform section, or centralized, provided in one section. Regardless, the driving of each wheel is based on the position sensed by the sensor associated with that wheel.

A pivoting shaft or other arrangement may be used to movably/rotatably join the two platform sections.

Referring to FIGS. 4-5, a top perspective view and a bottom perspective view of another embodiment of a two-wheel, self-balancing vehicle with independently movable platform sections 300 in accordance with the present invention is shown. Vehicle 300 is similar to the other vehicles herein, yet instead of a pivoting or rotating connection between platform sections, the frame or housing is made of a sturdy yet sufficiently flexible material that the two foot placement sections are effectively first and second platform sections that move independently with respect to each other for independent control of wheels 315,335.

Vehicle 300 may include a bottom 311 and a top 312 housing sections. These may be made of a flexible steel or durable flexible plastic or the like. The two sections are preferably configured to receive the internal components. They are preferably complementary in shape and may be secured by fasteners from below. The top housing may include or have attached to it a rubber coating or surface or the like in the foot placement areas 313,333 to increase traction and/or comfort with the foot of a user.

5

The internal components may include position sensors for both sections 320,340, hub motors 317,337, and control logic 350 for independently driving wheels 315,335 toward a self-balancing position based on position information [sensor] sensed by their respective sensors 320,340. These components may be the same or similar to those discussed above for vehicles 100 and 200 (FIGS. 1-3).

While the invention has been described in connection with specific embodiments thereof, it will be understood that it is capable of further modification, and this application is intended to cover any variations, uses, or adaptations of the invention following, in general, the principles of the invention and including such departures from the present disclosure as come within known or customary practice in the art to which the invention pertains and as may be applied to the essential features hereinbefore set forth, and as fall within the scope of the invention and the limits of the appended claims.

The invention claimed is:

[1. A two-wheel, self-balancing vehicle device, comprising:

a first foot placement section and a second foot placement section that are coupled to one another and are independently movable with respect to one another;

a first wheel associated with the first foot placement section and a second wheel associated with the second foot placement section, the first and second wheels being spaced apart and substantially parallel to one another;

a first position sensor and a first drive motor configured to drive the first wheel, a second position sensor and a second drive motor configured to drive the second wheel; and

control logic that drives the first wheel toward self-balancing the first foot placement section in response to position data from the first sensor and that drives the second wheel toward self-balancing the second foot placement section in response to position data from the second foot placement section.]

[2. The device of claim 1, wherein the first foot placement section and the second foot placement section are rotatably coupled to one another.]

[3. The device of claim 1, wherein the first foot placement section and the second foot placement section are positioned substantially linearly between the first and second wheel.]

[4. The device of claim 1, wherein said first and second foot placement sections are mounted to a frame that is sufficiently flexible that the first and second foot placement platforms can move independently with respect to one another under the weight of a user.]

[5. The device of claim 1, further comprising:

a first housing section on which the first foot placement section is provided, the first housing section housing the first sensor and first drive motor; and

a second housing section on which the second foot placement section is provided, the second housing section housing the second sensor and second drive motor.]

[6. The device of claim 5, wherein the control logic include a first control logic controlling the first drive motor located in the first housing section and a second control logic controlling the second drive motor located in the second housing section.]

[7. The device of claim 5, wherein the first drive wheel extends from the first housing section on an end substantially opposite where the first housing section is coupled to the second housing section, and the second drive wheel

6

extends from the second housing section on an end substantially opposite where the second housing section is coupled to the first housing section.]

[8. The device of claim 1, further comprising a platform sensor provided at at least one of the first and second foot placement sections that detects when a user is standing on that foot placement section.]

[9. The device of claim 1, further comprising a bias mechanism for returning the two independently movable first and second foot placement sections toward alignment in the absence of a force by a user displacing the two foot placement sections from alignment.]

10. A two-wheel, self-balancing vehicle device, comprising:

a first foot placement section and a second foot placement section that are rotatably coupled to one another;

a first wheel associated with the first foot placement section and a second wheel associated with the second foot placement section, the first and second wheels being spaced apart and substantially parallel to one another;

a first position sensor configured to sense the position of the first foot placement section;

a first drive motor configured to drive the first wheel; a second position sensor configured to sense the position of the second foot placement section; and

a second drive motor configured to drive the second wheel,

wherein the device excludes a steering structure that ascends upward from the foot placement sections, and wherein the first foot placement section is coupled to the second foot placement section such that the first foot placement section can rotate forward while the second foot placement section can rotate backward.

11. A two-wheel, self-balancing vehicle device, comprising:

a first foot placement section and a second foot placement section that are rotatably coupled to one another;

a first wheel associated with the first foot placement section and a second wheel associated with the second foot placement section, the first and second wheels being spaced apart and substantially parallel to one another;

a first position sensor configured to sense the position of the first foot placement section;

a first drive motor configured to drive the first wheel; a second position sensor configured to sense the position of the second foot placement section; and

a second drive motor configured to drive the second wheel,

wherein the device excludes a steering structure that ascends upward from the foot placement sections, and wherein the first foot placement section is coupled to the second foot placement section such that the first foot placement section can rotate in the same direction as, and more steeply than, the second foot placement section.

12. A two-wheel, self-balancing vehicle device, comprising:

a first foot placement section and a second foot placement section that are rotatably coupled to one another;

a first wheel associated with the first foot placement section and a second wheel associated with the second foot placement section, the first and second wheels being spaced apart and substantially parallel to one another;

7

a first position sensor configured to sense the position of the first foot placement section;
a first drive motor configured to drive the first wheel;
a second position sensor configured to sense the position of the second foot placement section; and
a second drive motor configured to drive the second wheel,

wherein the device excludes a steering structure that ascends upward from the foot placement sections, and wherein the vehicle is configured to move in a forward direction and a rearward direction, and wherein the first foot placement section is configured to rotate in the forward direction and the second foot placement section is configured to rotate in the rearward direction.

13. A two-wheel, self-balancing vehicle device, comprising:

a first foot placement section and a second foot placement section that are rotatably coupled to one another;
a first wheel associated with the first foot placement section and a second wheel associated with the second

8

foot placement section, the first and second wheels being spaced apart and substantially parallel to one another;

a processor; and

a first position sensor associated with the first foot placement section and a first motor configured to drive the first wheel, and a second position sensor associated with the second foot placement section and a second motor configured to drive the second wheel,

wherein tilting the first foot placement section forward results in the first wheel being driven forward, and tilting the first foot placement section more steeply forward than the second foot placement section is tilted forward results in the first wheel being driven faster forward than the second wheel, and wherein tilting the first foot placement section forward while tilting the second foot placement section backward results in the wheels being driven in opposite directions.

* * * * *