

(19) AUSTRALIAN PATENT OFFICE

(54) Title
A Continuously Adjustable Furring Channel Clip

(51)⁶ International Patent Classification(s)
E04B 1/38 (2006.01) 9/22
E04B 9/22 (2006.01) 20060101ALI2009110
E04F 13/00 (2006.01) 5BHAU E04F
E04B 1/38 13/00
20060101AFI2009110 20060101ALI2009110
5BHAU E04B 5BHAU

(21) Application No: 2009101115

(22) Application Date: 2009.10.30

(43) Publication Date : 2009.12.10

(43) Publication Journal Date : 2009.12.10

(62) Divisional of:
2007200753

(71) Applicant(s)
Rong Wang

(72) Inventor(s)
Wang, Rong Feng20091210

(74) Agent/Attorney
Halfords IP, Level 7 1 Market Street, Sydney, NSW, 2000

ABSTRACT

A panel frame attachment clip 200 includes a rail attachment member 211 and a support surface attachment member 201, the support surface attachment member and the rail attachment member being relatively movable to adjust the distance between the support surface and the rail by virtue of a pair of adjustment posts 218 and associated slots 222 on the support engagement member which align with threaded holes 214 on the rail attachment member. Screws 215 are used to lock the clip in the required position.

Figure 2

FIGURE 2

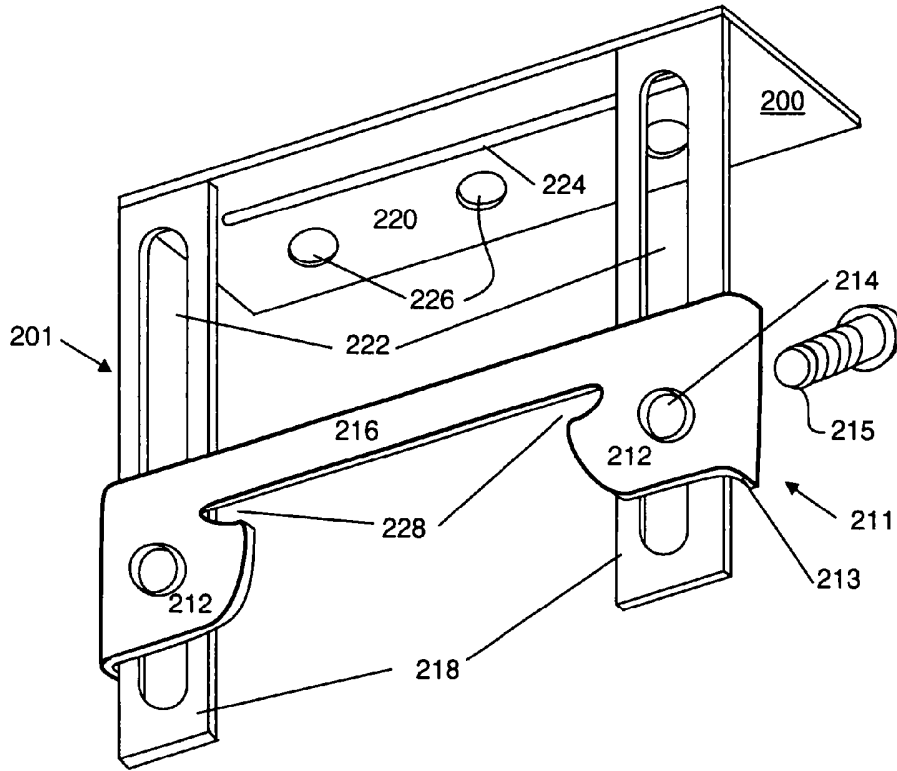

A Continuously Adjustable Furring Channel Clip

Field of the invention

[001] This invention relates to support brackets or attachment clips such as furring channel clips and the like.

[002] Furring channels and furring channels clips are used to attach panels to structural walls and ceilings. Channels can be used to carry the panels.

Background of the invention

[003] Decorative wall and ceiling panels such as fibre board or plasterboard etc., are fixed to the ceiling by the use of clips and frames formed of metal channels or rails. However the structural ceiling may not provide a level surface, so the decorative panels may not present a smooth, continuous surface because the clips are of fixed lengths and a compromise is required in selecting a clip for a specific location. Furthermore, the design specifications of different buildings may call for the panels to be spaced at different distances from the structural wall or ceiling. Thus a builder needs to access a supply of different length clips.

[004] Various clips such as those described in AU2004100681, WO1996/009449, DE2806872, and DE3409992 disclose clips with stepwise adjustment. However, these documents do not disclose a clip with continuous adjustability.

[005] The applicant does not concede that the references to prior art forms part of the common knowledge in the field.

Summary of the invention

[006] This invention proposes a furring channel attachment arrangement which is continuously adjustable.

[007] According to an embodiment of the invention, there is provided a furring channel clip including a base member and a channel attachment members, the first base member including a pair of slotted projections, the channel attachment member including a pair of threaded holes aligned with corresponding ones of the

slots of the projections, the clip including a pair of threaded connectors adapted cooperate with the threaded holes and the slots to slidably adjust the relative position of the base and the channel adjustment member.

[008] The channel attachment member can include a clip aperture having a pair of recesses to receive projecting flanges of a furring channel.

[009] The recesses can be spaced to form a resilient engagement with the flanges.

[010] The channel attachment member can include one or more slide stabilizing means adapted to engage with an edge of the corresponding projections to limit skewing between the rail attachment member and the second attachment member.

[011] The channel attachment member includes a recess having a lateral trapezoidal projection adapted to complement a portion of the profile of a channel.

[012] The invention thus provides a furring channel clip which is continuously relatively adjustable.

[013] The projections can have a roughened surface to increase friction with the fastening means.

[014] The base member can include a substantially planar attachment portion, and a pair of elongate adjustment posts substantially transverse to the attachment portion.

[015] The fastening means can include a threaded fastening arrangement.

[016] A levelling device such as a string level or laser leveller can be used to set the correct position of the connexion member.

[017] The furring channel clip can be made in various sizes to suit channels of differing dimensions. In particular, the width of the clip and/or the length of the adjustment limbs can be varied to suit different channel sizes.

Brief description of the drawings

[018] An embodiment or embodiments of the present invention will now be described, by way of example only, with reference to the accompanying drawings, in which:

[019] Figure 1 shows a portion of a furring channel;

[020] Figure 2 shows a furring channel clip;

[021] Figure 3 shows a cross-runner;

[022] Figure 4 shows a clip adapted to receive a cross-runner;

[023] Figure 5 shows a cross-runner and a furring channel;

[024] Figure 6 illustrates an arrangement including an alternative form of adjustment post;

[025] Figure 7 illustrates a further alternative adjustment post.

[026] The numbering convention used in the drawings is that the digits in front of the full stop indicate the drawing number, and the digits after the full stop are the element reference numbers. Where possible, the same element reference number is used in different drawings to indicate corresponding elements.

[027] It is understood that the drawings are intended to be illustrative rather than exact reproductions, and are not necessarily drawn to scale. The orientation of the drawings is chosen to illustrate the features of the objects shown, and does not necessarily represent the orientation of the objects in use.

Detailed description of the embodiment or embodiments

[028] The invention will be described with reference to the embodiments shown in the accompanying drawings. Figure 1 shows a furring channel 100 in the form of a "U" shaped channel having a base 102 to which the decorative panel can be attached, and side walls 104, 106. The free ends of the side walls terminate in outwardly extending flanges 108, 110. The ends of the flanges can be folded to provide strength. An attachment clip 111 from a furring channel clip is shown in dashed outline.

[029] Figure 2 shows a furring channel clip 200 having a channel attachment clip 211 adjustably connectable to a connexion member 201. The connexion member 201 is attached to a connexion base 220 with attachment holes 226. The panel can be screwed and/or glued to the channel.

[030] The attachment clip 211 has a pair of opposed end portions 212 joined by cross-member 216. Each of the end portions 212 includes a threaded hole 214 and an engagement recess 228. The engagement recess 228 is adapted to slidably receive a corresponding flange 108, 110 of the furring channel 100. In addition, each end portion 212 includes a slide stabilizing extension 213 which is adapted to engage against the slide "pillars" 218 of the connexion 201.

[031] The furring channel can be made of formed sheet material which has sufficient flexibility to enable the free ends to be pressed inwardly under hand pressure as indicated by arrows 118 so the flanges 108, 110 can engage with the engagement recesses 228.

[032] The connexion member 201 has a pair of slide grooves 222 formed in pillars 218. The slide grooves are adapted to align with the screw holes 214 and the clip 211 and connexion member 220 can be fixed together by screws as illustrated by 215.

[033] In operation, the connexion member 201 and the clip member 211 are loosely connected by screws 215 to permit relative movement between the base 220 and the clip 211. The clip 211 is attached to the furring channel by manually forcing the clip 211 over the flanges 108, 110 and compressing the free ends of the furring channel so the flanges engage with the recesses 228. When the manual force is removed the free ends of the furring channel wall expand and the flanges 108, 110 resiliently engage in the recesses 228. Then the clip is slidably adjusted to the required gap location and the screws 215 are tightened to hold the connexion member and clip in place.

[034] Typically, the furring channel clip adjustment slot may provide adjustment of the order of 20 mm.

- [035] A reinforcing ridge 224 can be pressed into the base 220 to improve strength.
- [036] Figure 3 shows a section of a top cross runner 300 in the form of a “U” shaped channel having a base 302 and side walls 304, 306. The free ends of the side walls terminate in flanges 308. The junction of the walls and the base is formed into a projection 310.
- [037] Figure 4 illustrates a cross runner clip 400 with a cross runner section 402 shown in dotted outline. The cross runner clip includes a runner engaging clip 411 slidably engageable with attachment member 401. The engaging clip 411 has a pair of opposed end portions 412 with screw holes 414 joined by a cross element 416. One or both the end portions 412 can include a slide stabilizing extension 413 which acts to reduce skewing of the elements 401, 411 while they are being adjusted.
- [038] The runner engaging clip 411 includes a trapezoidal projection 429 adapted to engage in the concavity formed between flange 308 and projection 310 of the runner 300. A recess 428 can be provided to engage a flange 308.
- [039] The engaging member 401 includes a pair of slide “pillars” 418 carrying slots 422, the slots being adapted to align with the threaded holes 414 of the runner clip 411. The base 420 of the engaging member 401 is adapted to enable connection. It includes holes 426. Reinforcing is provided by pressed groove 424.
- [040] As shown in Figure 4, the runner clip 400 can be used to enclose the runner 402. The rail attachment member and the engagement member are adapted to form a rail capture enclosure.
- [041] The adjustment pillars can be longer than the depth of the cross runner. As shown in Figure 5, the cross runner can be mounted on further rails such as furring channels.
- [042] Typically, the cross runner clip adjustment slot may provide of the order of 50 mm adjustment.
- [043] As shown in Figure 5, the cross runners 540 can be arranged transversely to the furring channels 560. Suitable attachment keys (not shown) can be

used to connect the cross runners and the furring channels. The cross runner may be formed of heavier gauge metal than the furring channel.

[044] Figure 6 illustrates an arrangement including an alternative form of connexion between the rail attachment member 662 and the engagement member 668. The slide posts 666 are of circular section, and the rail attachment member 662 includes post loops 664 adapted to fit around at least a portion of the corresponding posts 666 and to be fastened thereto by a screw 670.

[045] While the rail attachment member 662 is shown as a straight member with looped ends, the dashed lines indicate that it can also have the connexion arrangements of the engagement members 211 or 411.

[046] The posts 666 can be affixed to the base 620 by any suitable means such as screw attachment, welding, or other suitable means.

[047] Other shapes can be used for the adjustment posts. For example, Figure 7 illustrates an adjustment post 770 having an angle section which can be formed integrally with the base (not shown) by stamping, pressing, etc.

[048] The frictional engagement between the clip and the support can be enhanced by roughening the surfaces. A surface of the post can be roughened as shown at 772.

[049] Where ever it is used, the word "comprising" is to be understood in its "open" sense, that is, in the sense of "including", and thus not limited to its "closed" sense, that is the sense of "consisting only of". A corresponding meaning is to be attributed to the corresponding words "comprise", "comprised" and "comprises" where they appear.

[050] In this specification, reference to a document, disclosure, or other publication or use is not an admission that the document, disclosure, publication or use forms part of the common general knowledge of the skilled worker in the field of this invention at the priority date of this specification, unless otherwise stated.

[051] In this specification, terms indicating orientation or direction, such as "up", "down", "vertical", "horizontal", "left", "right" "upright", "transverse" etc. are

not intended to be absolute terms unless the context requires or indicates otherwise. These terms will normally refer to orientations shown in the drawings.

[052] It will be understood that the invention disclosed and defined herein extends to all alternative combinations of two or more of the individual features mentioned or evident from the text. All of these different combinations constitute various alternative aspects of the invention.

[053] While particular embodiments of this invention have been described, it will be evident to those skilled in the art that the present invention may be embodied in other specific forms without departing from the essential characteristics thereof. The present embodiments and examples are therefore to be considered in all respects as illustrative and not restrictive, and all modifications which would be obvious to those skilled in the art are therefore intended to be embraced therein.

Claims

1. A furring channel clip including a base member and a channel attachment members, the first base member including a pair of slotted projections, the channel attachment member including a pair of threaded holes aligned with corresponding ones of the slots of the projections, the clip including a pair of threaded connectors adapted cooperate with the threaded holes and the slots to slidably adjust the relative position of the base and the channel adjustment member.
2. A clip as claimed in claim 1, wherein the channel attachment member includes a clip aperture having a pair of recesses to receive projecting flanges of a furring channel.
3. A clip as claimed in claim 2, wherein the recesses are spaced to form a resilient engagement with the flanges.
4. A clip as claimed in any one of the preceding claims, wherein the channel attachment member includes one or more slide stabilizing means adapted to engage with an edge of the corresponding projections to limit skewing between the rail attachment member and the second attachment member.
5. A clip as claimed in claim 1, including frictional engagement enhancement between the mating surfaces of the projections and the clip.

FIGURE 1

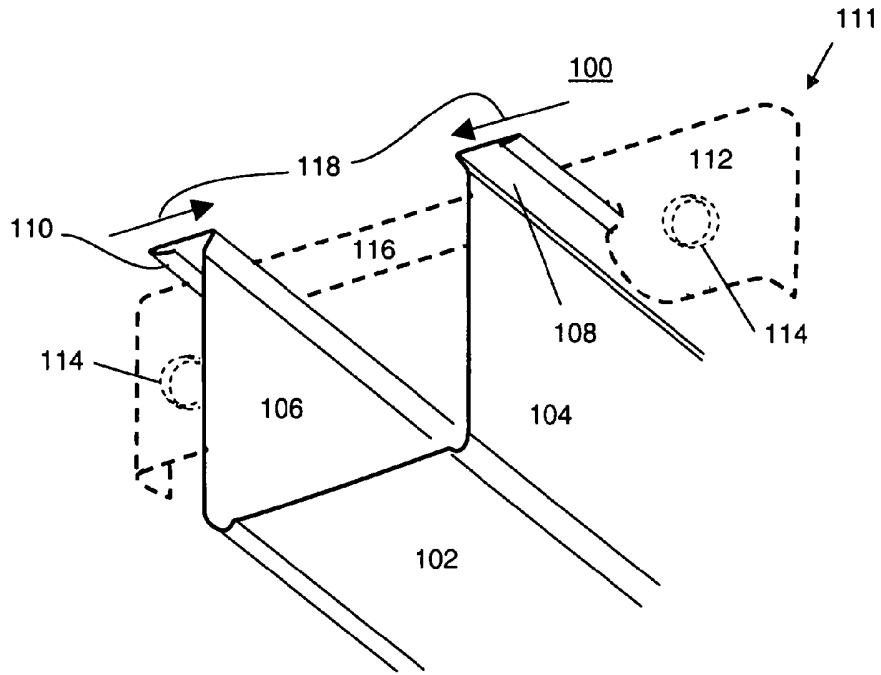

FIGURE 2

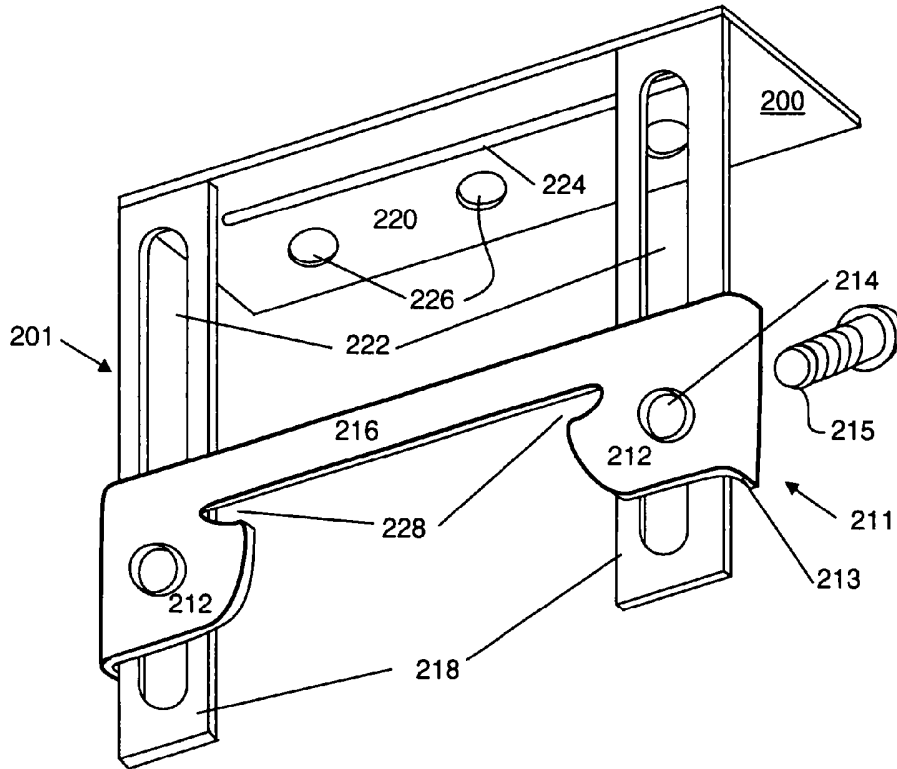

FIGURE 3

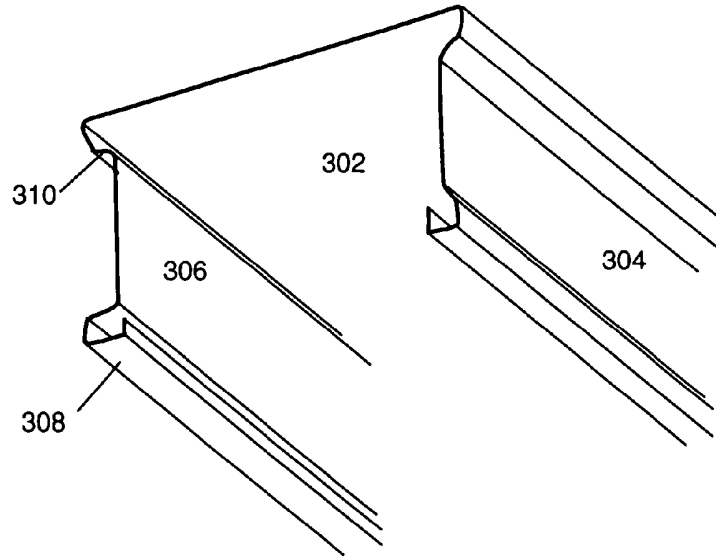

FIGURE 4

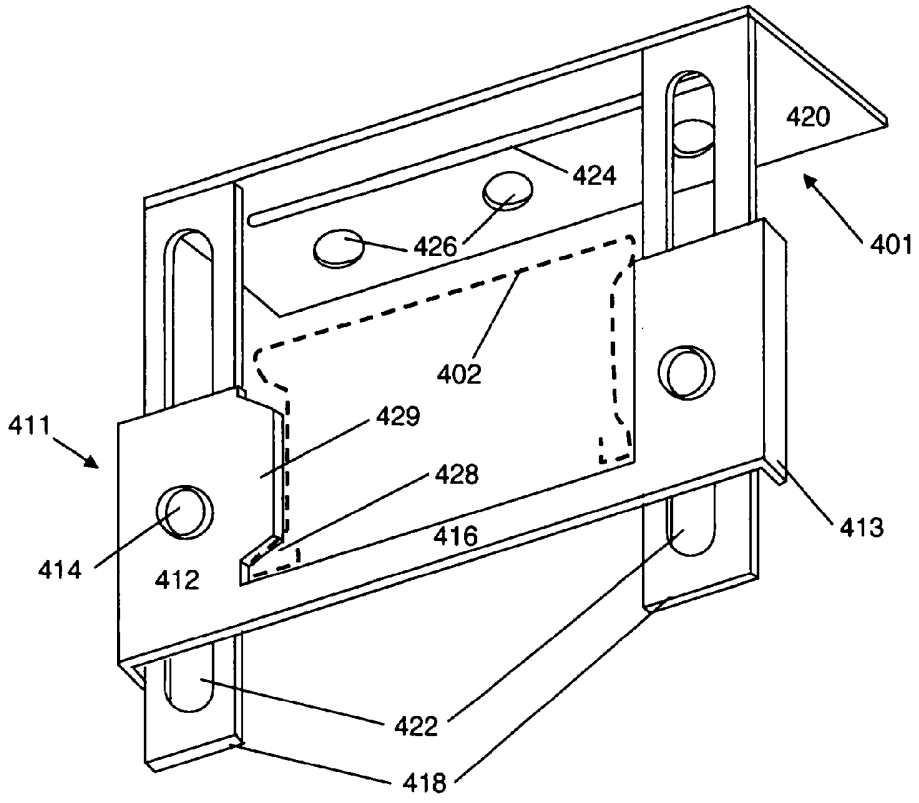

FIGURE 5

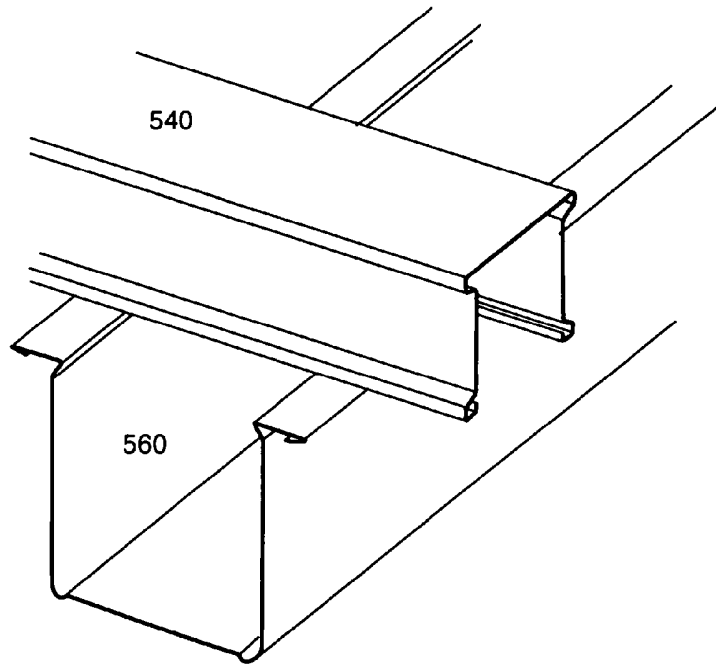

FIGURE 6

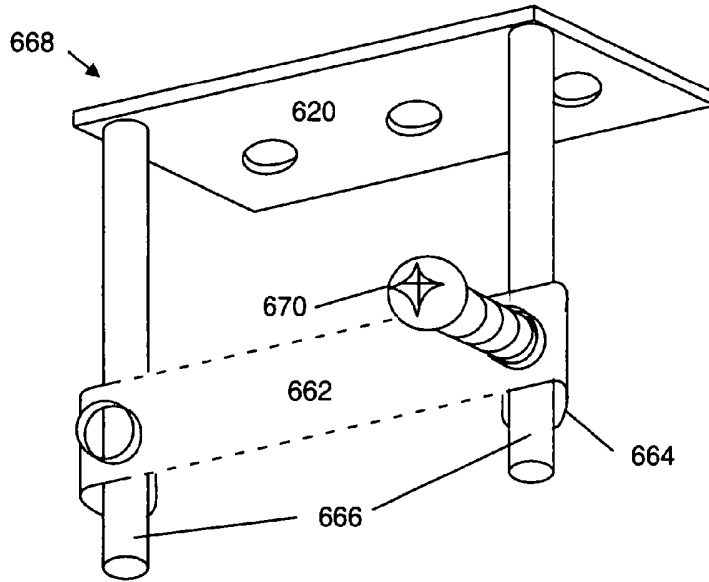

FIGURE 7

