

H. AIKEN.

APPARATUS FOR THE MANUFACTURE OF AXLES.

No. 415,402.

Patented Nov. 19, 1889.

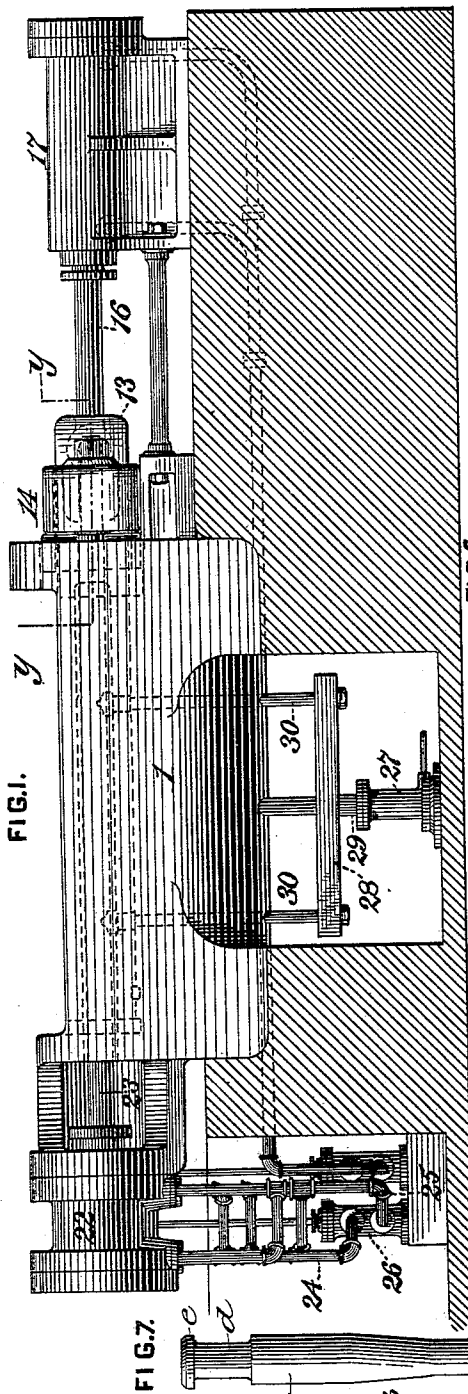

FIG. 1.



FIG. 6.

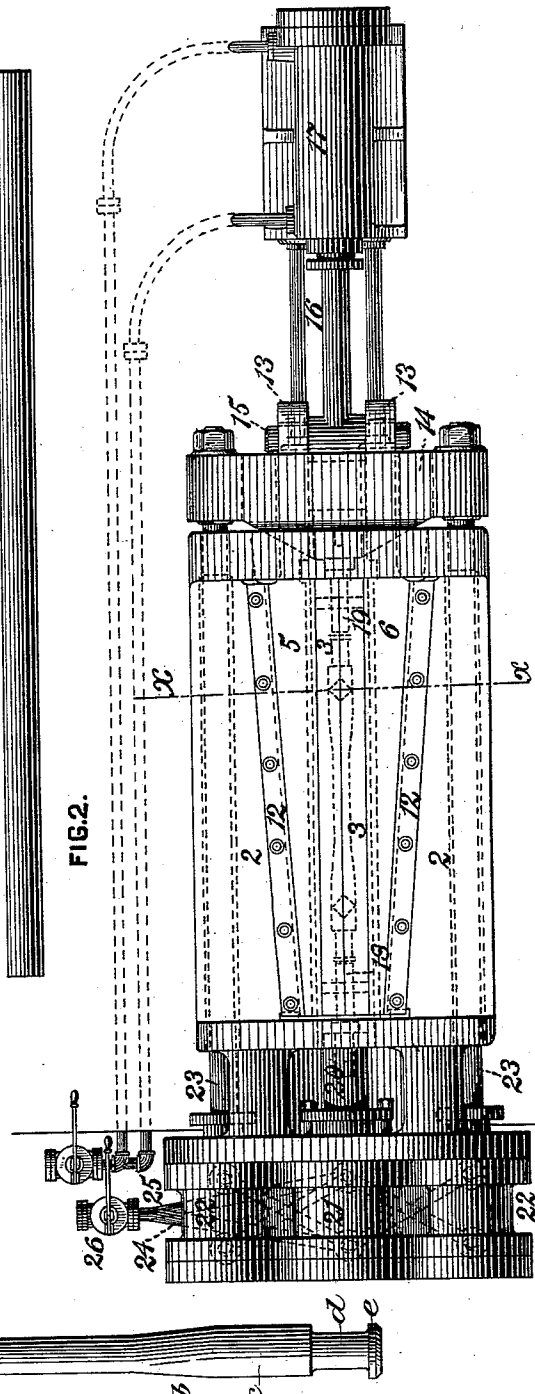

FIG. 2.

WITNESSES

R. H. Whittelsey
F. E. Gaither

INVENTOR

Henry Aiken
 by *George H. Christy*
attor

H. AIKEN.

APPARATUS FOR THE MANUFACTURE OF AXLES.

No. 415,402.

Patented Nov. 19, 1889.

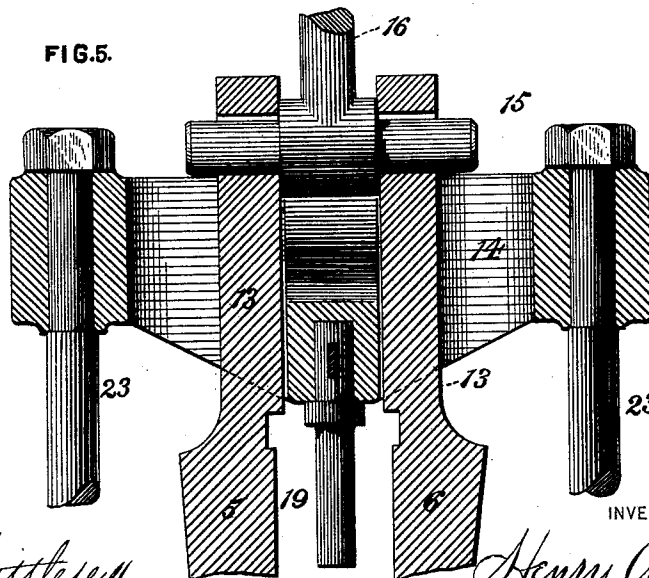
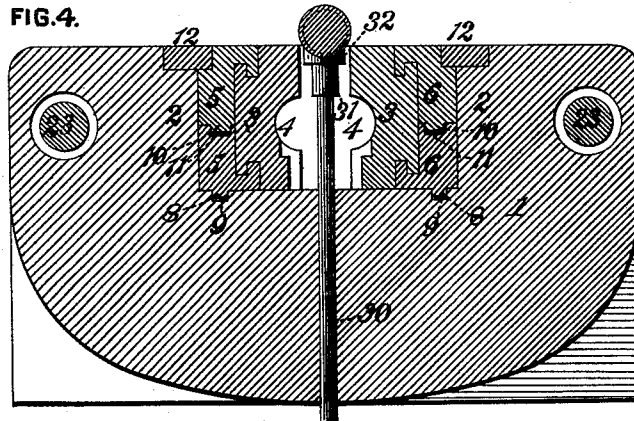
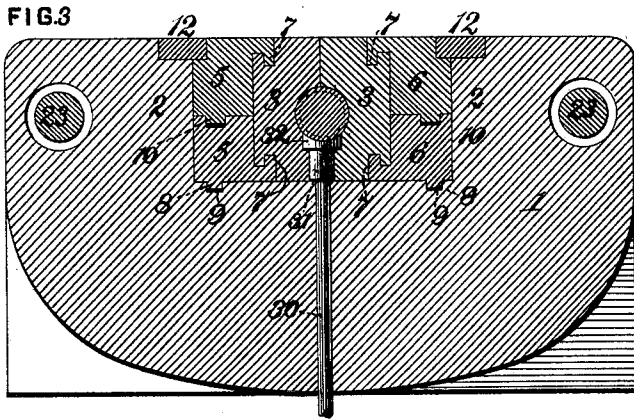

WITNESSES.

R. H. Whittlessey
F. E. Gardner

INVENTOR.

Henry Aiken
 By *George H. Christy*

Att'y.

(No Model.)

3 Sheets—Sheet 3.

H. AIKEN.

APPARATUS FOR THE MANUFACTURE OF AXLES.

No. 415,402.

Patented Nov. 19, 1889.

FIG. 8.

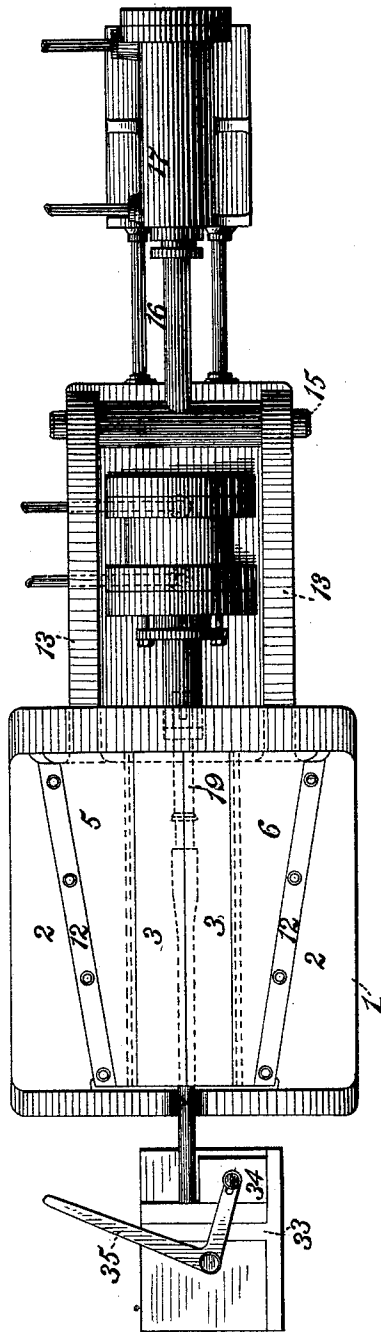

WITNESSES.

R. H. Whittless
H. E. Gaither

INVENTOR.

Henry Aiken
By *George H. Christy*

Att'y.

UNITED STATES PATENT OFFICE.

HENRY AIKEN, OF HOMESTEAD, ASSIGNOR TO CARNEGIE, PHIPPS & COMPANY, (LIMITED,) OF ALLEGHENY COUNTY, PENNSYLVANIA.

APPARATUS FOR THE MANUFACTURE OF AXLES.

SPECIFICATION forming part of Letters Patent No. 415,402, dated November 19, 1889.

Application filed December 24, 1888. Serial No. 294,497. (No model.)

To all whom it may concern:

Be it known that I, HENRY AIKEN, a citizen of the United States, residing at Homestead, in the county of Allegheny and State of Pennsylvania, have invented or discovered certain new and useful Improvements in Apparatus for the Manufacture of Axles, of which improvements the following is a specification.

In an application, No. 291,371, filed November 20, 1888, I have described and claimed certain improvements in the manufacture of railway-car axles, wherein a blank of suitable length and of a diameter approximately equal to the diameter of the axle to be produced at its smallest part is suitably shaped by pressure applied to the ends of the blank, thereby reducing the blank in length and enlarging certain portions near the ends thereof.

The invention described herein relates to certain improvements in apparatus employed in carrying out the method described in the application above referred to.

In the accompanying drawings, forming a part of this specification, Figure 1 is a view in side elevation of my improved apparatus. Fig. 2 is a top plan view of the same. Figs. 3 and 4 are sectional views taken in the plane indicated by the line *x x*, Fig. 2, the dies being shown closed in Fig. 3 and open in Fig. 4. Fig. 5 is a sectional view of the cross-head, taken on the plane indicated by the line *y y*, Fig. 1. Fig. 6 is a view in elevation of the blank. Fig. 7 is a similar view of the completed axle, and Fig. 8 is a sectional view of a modified form of apparatus.

In the practice of my invention the casting 1 is arranged upon a suitable foundation, as shown in Fig. 1. In the upper side of this casting is made a longitudinal recess forming jaws 2, having their inner faces inclined toward each other from end to end, as shown in Fig. 2. Between the jaws are placed dies 3, having their meeting faces recessed, as at 4, said recesses being constructed to form, when the dies are placed together, a matrix corresponding as to shape and dimensions to the axle to be formed. These dies 3 are moved toward and away from each other by means of the sectional wedges 5 and 6, said wedges being arranged between the dies and the jaws 2, and connected to said dies by means of lugs 7, engaging grooves formed in

the upper and lower faces of the dies, as shown in Figs. 3 and 4. In order to insure a separation of the wedges and with them of the dies when the former are shifted longitudinally outward, as hereinafter described, said wedges are provided with tongues 8, engaging grooves 9 formed in the casting 1 parallel with the faces of the jaws 2, and the sections forming each wedge are connected together in order to insure simultaneous lateral movements of both sections by means of tongues 10 and grooves 11, as shown in Figs. 3 and 4. The grooves 9 and 11 should be made somewhat wider than the tongues 8 and 10, and so located with reference to the jaws 2 as to prevent the lateral thrust of the wedges being taken up by the tongues rather than the jaws 2. The wedges are held in position as against vertical movement by the plates 12, bolted to the jaws 2 and extending over the wedges, as shown in Figs. 2, 3, and 4. Each wedge is provided at one end with a shank 13, extending through the cross-head 14 and connected by a pin 15 to the piston-rod 16 of the fluid-pressure cylinder 17, as shown in Figs. 1, 2, and 5.

The dies 3 are provided in their meeting faces at the ends of the matrices proper with circular grooves for the reception of the excess of length at each end of the blank, as hereinafter stated, and also to permit of the movement of the plungers 18 and 19 in the upsetting operation, as indicated by dotted lines in Fig. 2.

The plunger 18 is secured to the piston 20 of the fluid-pressure cylinder 21, arranged with its axis in line with the plunger 18, and on opposite sides of the cylinder 21 are placed the fluid-pressure cylinders 22. The piston-rods 23 of said cylinders extend through passages in opposite sides of the casting 1 to the cross-head 14, and to this cross-head is attached the plunger 19, as shown in Figs. 2 and 5. The cylinders 22 are so proportioned as to their diameters that the power exerted by said cylinders shall equal that exerted by the cylinder 21, so that when said cylinders are operating on a blank through the medium of the plungers 18 and 19 the power exerted by cylinders 22 shall counterbalance that exerted by the large cylinder 21.

In order to insure practically simultaneous

action of each cylinder, the fluid-pressure-conducting pipes from each cylinder are connected to common supply-pipes 24 and 25, leading to the valve mechanism 26, as shown in Figs. 1 and 2.

As stated in the application hereinbefore referred to, the blank *a* is reduced by rolling or forging to a uniform diameter throughout its entire length, such diameter being equal, or practically so, to the diameter of the axle to be made at its smallest part. The blank should exceed the length of the desired axle by an amount sufficient to supply the metal necessary for the required enlargements of the blank near its ends, as shown in Fig. 7, such enlargements forming the neck *b*, wheel-seat *c*, journal *d*, and collar *e*. After being properly heated the blank is placed between the dies, which are then closed by the wedges actuated by the cylinder 17. The blank having been firmly grasped by the dies, fluid-pressure is admitted to the cylinders 21 and 22, thereby forcing the plungers 18 and 19 inward, upsetting the ends of the blank and causing portions to expand outward and fill the matrix of the dies. The plungers are then retracted, the dies opened by moving the wedges outwardly in a longitudinal direction, as hereinbefore stated, the completed axle removed, and another blank inserted.

In order to facilitate the removal of the axle and the placing of a blank in position between the dies, a fluid-pressure cylinder 27 is arranged beneath the casting 1, and on the cross-head 28, carried by the piston-rod 29 of said cylinder, bars or rods 30 are secured. These rods 30 pass up through openings in the casting 1, as shown in Figs. 1, 3, and 4, said openings being arranged in a vertical plane passing through the parting-line of the dies 3.

On the upper ends of the rods 30 are placed crutches, consisting of a shank or stem 31 and a concave head 32. The shank and head are constructed so as to have the one a firm bearing on the bottom of the recess in the casting and the other on the bottom of a recess formed in the dies for the reception of the crutches when lowered. By means of these crutches the finished axle can be raised sufficiently high to permit of its being rolled or pushed to one side. A blank is then placed on the crutches and lowered into position for being grasped by the dies.

If desired, any lettering or other mark which is to be placed on the axle can be cut in reverse on the concave surfaces of the head 32, and the metal of the blank will be forced into said mark or lettering by the upsetting operation, as will be readily understood.

As shown in Figs. 3 and 4, the stem 31 of the crutch rests upon the bottom of the recess in the casting, and hence during the upsetting operation hereinbefore described and consequent expansion of portions of the blank the crutch will act as an anvil and there will be an upward pressure exerted upon the dies

proportional to the area of the heads 32 and the expansive force of the metal. All tendency to displacement of the dies by reason of this upwardly-acting force is counterbalanced by the fluid-pressure cylinder 27, acting through the heads 32, which engage shoulders in the dies, as hereinbefore described.

As shown in Fig. 8, the apparatus may be modified so as to operate upon one end of the blank at a time. In this "single apparatus," as I prefer to term it, the shaping-dies are made so as to inclose only about half the blank and only one plunger is employed in the upsetting operation. The dies are opened and closed by means of wedges, as in the double apparatus, said wedges being provided with shanks sufficiently long and arranged at such a distance apart that the fluid-pressure cylinder employed for operating the plunger may be arranged between said shanks.

In order to insure the proper adjustment of both ends of the blank within the dies, I provide a stop 33, so located as to properly adjust the blank within the dies for the first upsetting operation. As this upsetting operation shortens the blank considerably, I provide a sliding block 34, which can be moved across the face of the stop 33 into line with the axis of the dies by means of the lever 35. This block is made of a thickness equal to the amount of reduction effected by the first upsetting operation, and after one end of the blank has been shaped the blank is removed from the dies, the block 34 moved into position, and the opposite end of the blank placed in the dies, the end of the blank previously operated on resting against the block 34.

I claim herein as my invention—

1. In an apparatus for the manufacture of axles, the combination of separable dies having in their adjacent faces recesses suitably shaped for the formation of wheel-seats, journal, and collars on the end of a blank, and a plunger operative against the end of a blank held by said dies, whereby said blank is reduced in length and expanded laterally to fill the recesses, substantially as set forth.

2. In an apparatus for the manufacture of axles, the combination of separable dies having in their adjacent faces recesses suitably shaped for the formation of wheel-seats, journals, and collars on the ends of a blank, and plungers operative in opposite directions against the ends of a blank held by said dies, whereby said blank is reduced in length and portions thereof expanded laterally to fill the recesses in the dies, substantially as set forth.

3. In an apparatus for the manufacture of axles, the combination of stationary jaws, separable dies located between said jaws, wedges interposed between the jaws and dies and adapted to open and close the latter, and plungers operative in opposite directions against the ends of a blank held by said dies, substantially as set forth.

4. In an apparatus for the manufacture of axles, the combination of separable dies having their meeting faces recessed to form a matrix, and crutches movable transversely of the matrix and having their faces forming a part of said matrix, substantially as set forth.

5. In an apparatus for the manufacture of axles, the combination of separable dies, plungers operative on the ends of the blank held by said dies, crutches movable transversely of the dies and having their heads arranged in recesses in the dies, and a fluid-pressure cylinder for operating said crutches, substantially as set forth.

6. In an apparatus for the manufacture of axles, the combination of stationary jaws, separable dies arranged between said jaws, and sectional wedges arranged between the dies and jaws and interlocking with the dies, substantially as set forth.

7. In an apparatus for the manufacture of

axles, the combination of stationary jaws, separable dies located between said jaws, wedges arranged between the dies and jaws, and a fluid-pressure cylinder for operating the wedges, substantially as set forth.

8. In an apparatus for the manufacture of axles, the combination of separable dies, plungers for operating on the opposite ends of a blank held by the dies, and fluid-pressure cylinders located at one end of the dies, one of the cylinders having its piston-rod connected to one of the plungers, the other cylinders having their rods connected through suitable mechanism to the other plunger, substantially as set forth.

In testimony whereof I have hereunto set my hand.

HENRY AIKEN.

Witnesses:

R. H. WHITTLESEY,
DARWIN S. WOLCOTT.