



(12) **DEMANDE DE BREVET CANADIEN
CANADIAN PATENT APPLICATION**

(13) **A1**

(22) **Date de dépôt/Filing Date:** 2020/02/11
(41) **Mise à la disp. pub./Open to Public Insp.:** 2020/08/27
(62) **Demande originale/Original Application:** 3 126 714
(30) **Priorité/Priority:** 2019/02/18 (US16/278,560)

(51) **Cl.Int./Int.Cl. E04F 15/02** (2006.01),
B32B 18/00 (2006.01), **B32B 27/04** (2006.01),
B32B 27/38 (2006.01), **B32B 37/10** (2006.01),
B32B 37/12 (2006.01), **B32B 38/10** (2006.01),
B32B 7/12 (2006.01), **E04F 15/08** (2006.01),
E04F 21/22 (2006.01)
(71) **Demandeur/Applicant:**
DAL-TILE CORPORATION, US
(72) **Inventeurs/Inventors:**
CASELLI, CLAUDIO, US;
PATKI, RAHUL, US;
DE RICK, JAN EDDY, BE
(74) **Agent:** ROBIC AGENCE PI S.E.C./ROBIC IP AGENCY
LP

(54) **Titre : ELEMENT DE PLANCHER POUR LA FORMATION D'UN REVETEMENT DE SOL, REVETEMENT DE SOL, ET PROCEDE DE FABRICATION D'UN ELEMENT DE PLANCHER**
(54) **Title: A FLOOR ELEMENT FOR FORMING A FLOOR COVERING, A FLOOR COVERING, AND A METHOD FOR MANUFACTURING A FLOOR ELEMENT**

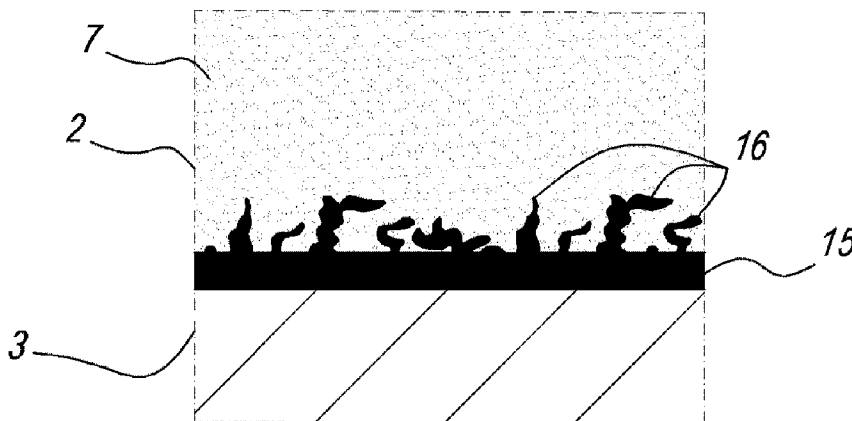

(57) **Abrégé/Abstract:**

A floor element for forming a floor covering, wherein the floor element comprises a board having edges provided with coupling elements adapted to cooperate with coupling elements of an adjacent similar floor element in said floor covering wherein the coupling elements comprise at least one male part and at least one female part said male part being positioned along a first edge and protruding outwardly beyond an upper edge at said first edge, said female part being positioned along a second edge and extending inwardly beyond an upper edge at said second edge to thereby form a recess for at least partially receive the male part, wherein said recess comprises an inlet opening having a vertical breadth, with the characteristic that the ratio between the vertical breadth and the thickness of the board is more than 0.4.

Abstract

A floor element for forming a floor covering, wherein the floor element comprises a board having edges provided with coupling elements adapted to cooperate with coupling elements of an adjacent similar floor element in said floor covering wherein the coupling elements comprise at least one male part and at least one female part said male part being positioned along a first edge and protruding outwardly beyond an upper edge at said first edge, said female part being positioned along a second edge and extending inwardly beyond an upper edge at said second edge to thereby form a recess for at least partially receive the male part, wherein said recess comprises an inlet opening having a vertical breadth, with the characteristic that the ratio between the vertical breadth and the thickness of the board is more than 0.4.

A FLOOR ELEMENT FOR FORMING A FLOOR COVERING, A FLOOR COVERING, AND A METHOD FOR MANUFACTURING A FLOOR ELEMENT

TECHNICAL FIELD

The present invention relates to a floor element for forming a floor covering, a floor covering,
5 and a method for manufacturing a floor element.

More particularly, the invention is related to a floor element for forming a floor covering,
wherein this floor element comprises a board having coupling edges having edges provided with
coupling elements adapted to cooperate with coupling elements of an adjacent similar floor element in
said floor covering and wherein the coupling elements comprise at least one male part and at least one
10 female part.

BACKGROUND

An example of said floor element is described in WO 97/47834 A1. Said kind of floor elements
has become more and more important in the recent years due to the easiness of installation provided
by the coupling elements. In fact, a floor covering can be quickly installed by non-professional
15 installer and, in case of restoration, without the necessity of removing the pre-existing floor covering.
Furthermore, thanks to the coupling elements, the floor covering is substantially flat and well
levelled. In fact, since the floor elements are not glued to the subfloor there is no glue accumulation
below the floor elements that can affect the leveling of the floor covering.

Due to the material properties and/or to the manufacturing process, the floor elements may be
20 bowed and/or have a substantially convex shape in such a way that, for example, a central portion of
the floor element is disposed at an upper level with respect to the extremal portion. In this case it could
be difficult to couple together the coupling elements of the floor elements, especially in case the floor
elements are disposed in an offset configuration. In fact, in this case, for example, it would be difficult,
if not impossible, to insert the male part of the central portion of a first floor element into the female
25 part of the extremal portion of a second adjacent element, since they are on different heights. Moreover,
in this coupled condition the couple elements are highly solicited, and they could break or damage.

This problem is enhanced when the floor element comprises a board made of a rigid material and/or when the floor element comprises a decorative layer provided above said board and wherein the decorative a decorative layer is made of a brittle material such as natural stone, glass or sintered ceramic materials like porcelain, earthenware or the like. The decorative layer
5 can be, for example, a ceramic tile. Examples of said floor elements are shown in WO 2004/097141 and WO 2008/097860.

The present invention aims in the first place to provide an alternative floor element, which, in accordance with several of its preferred embodiments, is directed to solve one or more of the problems arising in the state of the art.

10

BRIEF SUMMARY OF THE INVENTION

In a first aspect, the invention provides a floor element for forming a floor covering, wherein the floor element comprises a board having edges provided with coupling elements adapted to cooperate with coupling elements of an adjacent similar floor element in said floor covering wherein the coupling elements comprise at least one male part and at least one female
15 part said male part being positioned along a first edge and protruding outwardly beyond an upper edge at said first edge, said female part being positioned along a second edge and extending inwardly beyond an upper edge at said second edge to thereby form a recess for at least partially receive the male part, wherein said recess comprises an inlet opening having a vertical breadth, with the characteristic that the ratio between the vertical breadth and the
20 thickness of the board is more than 0.4.

In another aspect, the invention provides a floor element for forming a floor covering, wherein this floor element comprises a decorative layer made of a ceramic material and a board arranged below this decorative layer, wherein the floor element comprises a layer having a resin material disposed below the decorative layer, and wherein said resin compresses the
25 decorative layer.

In another aspect, the invention provides a floor covering comprising a plurality of adjacent floor elements as described herein, and wherein the floor covering comprises a grout filling an intermediate distance separating the decorative layers of the floor elements.

In another aspect, the invention provides the use of a resin material for bonding together
30 a decorative layer made of a ceramic material and a board to form a floor element, wherein the resin material comprises a viscosity at 20°C less than 1000 mPas, preferably less than 800 mPas, more preferably less than 600 mPas, for example approximately 400 mPas.

In another aspect, the invention provides a method for manufacturing a floor element comprising the steps of: providing a decorative layer made of a ceramic material; providing a board; providing a resin material for bonding the decorative layer and the board together; pressing the layers together for forming the floor element such that the resin material permeates the ceramic layer.

In another aspect, the invention provides a method for manufacturing a floor element comprising the steps of: providing a decorative layer made of a ceramic material; providing a board; providing a resin material for bonding the decorative layer and the board together; cure the resin; promote the shrinkage of the resin.

In another aspect, the invention provides a tool suitable for installing a floor covering having floor elements, wherein the floor elements comprise a decorative layer and a board disposed below the decorative layer and wherein the board having edges provided with coupling elements adapted to cooperate with coupling elements of an adjacent similar floor element in said floor covering, wherein the first tool comprises a body having first beating surface adapted to contact a surface of the decorative layer, and at least a second beating surface adapted to be hammered.

In another aspect, the invention provides a tool suitable for installing a floor covering, wherein the floor covering comprises a board having edges provided with coupling elements adapted to cooperate with coupling elements of an adjacent similar floor element in said floor covering, wherein the second tool comprises an handle portion and a plane portion provided with at least one edge and wherein said edge is provided with a coupling element to be coupled with at least one coupling element of the board.

In another aspect, the invention provides a kit for installing a floor covering having floor elements, wherein the floor elements comprise a decorative layer and a board disposed below the decorative layer and wherein the board having edges provided with coupling elements adapted to cooperate with coupling elements of an adjacent similar floor element in said floor covering, wherein the kit comprises at least one tool as described herein.

In another aspect, the invention provides a kit for installing a floor covering having floor elements, wherein the floor elements comprise a decorative layer and a board disposed below the decorative layer and wherein the board having edges provided with coupling elements adapted to cooperate with coupling elements of an adjacent similar floor element in said floor covering, wherein the kit comprises an automatic and/or electric hammer having a

body adapted to be handled by at least an operator and a body housing a motor or operating element adapted to activate an operative end, said end being adapted to cooperate with an edge of the decorative layer and/or with a second beating surface of between the first and second tool as described herein.

5 In another aspect, the invention provides an automatic and/or electric hammer for installing a floor covering having floor elements, wherein the floor elements comprise a decorative layer and a board disposed below the decorative layer and wherein the board having edges provided with coupling elements adapted to cooperate with coupling elements of an adjacent similar floor element in said floor covering, said automatic and/or electric hammer
10 having a body adapted to be handled by at least an operator and a body housing a motor or operating element adapted to activate an operative end, said end being adapted to cooperate with an edge of the decorative layer and/or with a second beating surface of between the first and second tool as described herein.

 In another aspect, the invention provides a kit for installing a floor covering having
15 floor elements, wherein the floor elements comprise a decorative layer and a board disposed below the decorative layer and wherein the board having edges provided with coupling elements adapted to cooperate with coupling elements of an adjacent similar floor element in said floor covering, wherein the kit comprises an automatic and/or electric hammer as described herein, and at least one other tool as described herein.

20 In another aspect, the invention provides a floor element for forming a floor covering, wherein the floor element comprises edges provided with coupling elements adapted to cooperate with coupling elements of an adjacent similar floor element in said floor covering, wherein said floor element has a decorative layer provided above a board, wherein said decorative layer comprises a brittle material, for example ceramic, porcelain, natural stone,
25 concrete, glass or glass-ceramic material, and wherein the board comprises a cement-based material, or a mineral based material, preferably a mineral-based material comprising magnesium, more preferably magnesium oxide.

 These and other objects, features and advantages of the present invention will become more apparent upon reading the following specification in conjunction with the accompanying
30 description, claims and drawings.

BRIEF DESCRIPTION OF THE DRAWINGS

The accompanying Figures illustrate several aspects described below.

Figure 1 shows a top view of a first embodiment of a floor element of the invention;

Figure 2 on a larger scale shows a cross section along the line II-II of Figure 1;

Figure 3 on a larger scale shows a view on the area F3 indicated on Figure 2;

5 Figure 4a and 4b on a larger scale respectively show a view of the areas F4a and Fb indicated on Figure 2;

Figure 5 on a smaller scale shows a top plane view of a floor covering comprising a plurality of the floor elements of Figure 1;

Figure 6 on a larger scale shows a cross section along the line VI-VI of Figure 5;

10 Figure 7 on a larger scale shows a view on the area F7 indicated on Figure 6;

Figure 8 show a schematic side view of a floor element of Figure 1;

Figure 9 on a smaller scale shows a top plane view of a floor covering comprising a plurality of the floor elements according to a second embodiment of the invention;

Figure 10 on a larger scale shows a cross section along the line X-X of Figure 9;

15 Figure 11 on a larger scale shows a view on the area F11 indicated on Figure 10;

Figure 12 shows some steps of a method for manufacturing a floor element.

Figure 13 shows a top plane view of a kit for installing the floor elements for forming the floor covering.

20 Figure 14 on a larger scale shows a cross section of a first embodiment of a first tool of the kit along the line XIV-XIV of Figure 13.

Figure 15 on a larger scale shows a cross section of an alternative embodiment the first tool of the kit along the line XV-XV of Figure 13.

Figure 16 on a larger scale shows a cross section of the second tool along the line XVI-XVI of Figure 13.

25 **DETAILED DESCRIPTION OF THE INVENTION**

Thus, the present invention, according to a first independent aspect, relates to a floor element for forming a floor covering, wherein the floor element comprises a board having

edges provided with coupling elements adapted to cooperate with coupling elements of an adjacent similar floor element in said floor covering wherein the coupling elements comprise at least one male part and at least one female part said male part being positioned along a first edge and protruding outwardly beyond an upper edge at said first edge, said female part being positioned along a second edge and extending inwardly beyond an upper edge at said second edge to thereby form a recess for at least partially receive the male part, wherein said recess comprises an inlet opening having a vertical breadth, with the characteristic that the ratio between the vertical breadth and the thickness of the board is more than 0.4, preferably more than 0.45, more preferably more than 0.5, even more preferably about 0.53. In other words, the vertical breadth is at least 0.4 times the thickness of the board, preferably more than 0.45 times, more preferably more than 0.5 times, even more preferably about 0.53 times. Preferably, the ratio between the vertical breadth and the thickness of the board is comprised between 0.4 and 0.7, preferably between 0.5 and 0.6. A female part of the coupling element having an enlarged vertical inlet opening provides the possibility to engage the male part with the female part of two adjacent floor elements even in case of highly bended floor elements. In fact, in this way a male part can engage an adjacent female part even if it is at a different height. This is particularly the case of an offset installation wherein the central portion of one floor element is at an upper height with respect of the extremal portion of an adjacent floor element. Moreover, this characteristic provides for an eased insertion of the male part into the female part so that subsequently, once complete engagement between the coupling elements is reached, they can still lock to prevent vertical and/or horizontal movements between the floor elements.

It is to be noted that the vertical breadth of said inlet opening is preferably measured substantially on the vertical plane on which lies the upper edge of said first edge.

It is also to be noted that preferably the vertical breadth of the inlet opening may correspond to the maximum breadth of the recess of the female part.

According to a preferred embodiment of the invention, the vertical breadth is above 1.6 mm, preferably above 1.8 mm, more preferably above 2 mm. In this way it would be possible to couple two floor elements having a planarity deviation of 1 mm or more measured between the center and the ends of the edge, even in a 50/50 offset installation.

Moreover, between the upper border of the inlet opening of the recess and the upper edge of said first edge, is provided a distance. The ratio between said distance and the thickness of the board can be below 0.2, preferably below 0.15. For example, said ratio can be comprised

between 0.2 and 0.1. A reduced distance between the inlet opening and the upper edge increases the chances of easily inserting the male part into the recess of the female part in case the male part is disposed at an upper level with respect to the recess. For example, said distance can be below 0.9 mm, preferably below 0.6mm. For example, said distance can be comprised between
5 0.9 and 0.4 mm.

According to an embodiment of the invention, the recess may comprise a first portion close to the inlet opening and a second portion close to the bottom of said recess. Preferably, said first portion is larger than the second portion, wherein with larger it is meant with respect with the vertical dimension of the recess. Preferably said first portion may extends toward the
10 bottom of the recess for a deepness/depth that is at least 0.3 times the whole maximum deepness/depth of the recess, i.e. the sum of the deepness/depth of the first and of the deepness of the second portion. Preferably, the deepness/depth of the first portion is at least 0.4 times, more preferably at least 0.5 times (i.e. at least the half) of the whole maximum deepness/depth of the recess. Said deepness/depth shall be measured starting from the inlet opening, i.e. from
15 substantially form a vertical plane parallel to the longitudinal edge and on which lies the upper edge of said first edge. Therefore, the deepness/depth of the first portion is measured starting from the inlet opening until the transition between the first and the second portion. Whereas the whole maximum deepness/depth of the recess is measured starting from the inlet opening until bottom of the recess. Having such a deep first portion improves the engagement between
20 the male and the female part. The first portion is enlarged to pilot the male part into the female part and the second portion is narrower in order to provide a vertical locking. Therefore, making the first portion deeper improves the efficacy of this piloting effect in particular when the coupling is difficult because of unevenness of the subfloor or in case of planarity deviation of the floor element. According to a preferred embodiment said deepness/depth of the first portion
25 is more than 0.5 mm, preferably more than 0.75 mm, for example more than 1mm. For example, said deepness of the first portion is comprised between 0.5 and 1.5 mm, preferably between 0.75 and 1.25 mm. Preferably said first portion comprises an inclined upper surface descending toward the bottom of the recess. More preferably said inclined upper surface is inclined with respect to the horizontal of an angle comprised between 30° and 50°, for example about 45°.
30 This would improve the abovementioned piloting effect of the first portion. The transition between the first and the second portion substantially coincides with a change in the inclination of said inclined upper surface, in particular when said angle diminishes.

It is to be noted that, said male and female part in a connected state of two similar floor elements engage into each other to create a mechanical coupling between the respective edges, preferably resulting in a locking between said edges in vertical and/or one or more horizontal directions. The term “mechanical coupling” includes a coupling that allows adjacent floor elements to be coupled to each other without the need for glue or the like.

As used herein, the terms “horizontal” and “vertical” are basically expressed regarding a floor covering installed on a surface which is considered to be horizontal in its general meaning. Thus, when used regarding a single floor element which is a substantially flat element provided with a main plane, the terms “horizontal” and “vertical” are to be considered respectively equivalent to the terms “parallel with respect to the main plane of the floor element/installed floor elements” and “perpendicular with respect to the main plane of the floor element/installed floor elements”.

Furthermore, in a coupled condition of two of said adjacent floor elements, the coupling elements cooperate and preferably form locking surfaces limiting the mutual movement of said floor elements in vertical and/or one or more horizontal directions. Preferably, in a coupled condition of two adjacent floor elements, first locking surfaces are formed limiting the mutual movement of said floor elements in a direction perpendicular to the coupled edges and in a substantially horizontal plane. Furthermore, in said coupled condition, second locking surfaces are formed limiting the mutual movement of said floor elements in a substantially vertical direction. Due to this solution, the floor elements can fluently be installed without the occurrence of unacceptable height differences between adjacent floor elements. Moreover, the floor elements are solidly coupled to each other to improve the fatigue behavior of the floor covering. Further, by limiting relative movement of the floor element, it is possible to reduce the step noise effect, i.e. reduce the noise generated at every step.

According to a preferred embodiment of the invention, the male part and female part can be disposed substantially along the whole length of the related edge, for example, substantially defining the related edge. For example, according to this embodiment, the male and the female parts, can be basically shaped as a tongue and a groove that substantially runs through the whole length of the related mutually opposite edges. Preferably, the male part is positioned at a first edge of the floor element and at least the female part is positioned at a second opposite edge of the floor element.

Alternatively, the male part and the female part may extend over a limited length portion of the related edge, wherein such limited length is smaller than the whole length of the related edge itself, preferably smaller than half the length of the related edge. In accordance with this possibility, the edges preferably comprise sections free from said male part and said female parts. Geometries for coupling parts in accordance with this alternative embodiment include cooperating male and female parts which in a top plan view are dovetail-shaped or male and female parts which in a top plan view resemble the connections of jigsaw puzzles.

In some embodiments the coupling elements are configured so that, in a coupled condition, a pretensioned state is established between the coupling element. In other words, the coupling element are configured so that in the coupled condition they are elastically deformed thereby exerting a counter reaction on each other. Due to this solution the coupling between the floor element is strengthened and the coupling itself helps the waterproofing of the floor covering. According to a preferred embodiment of the invention the coupling elements are configured so that, in a coupled condition, the coupling is free from pretension so that the coupling is simplified, and a lower force needs to be exerted by the operator. That is to say that, in the coupled condition the coupling elements are in an undeformed condition. Moreover, also the coupling movement of the coupling element, i.e. the relative movement between the coupling elements that allows the mechanical coupling, occurs without deformation of the coupling elements. For example, in some embodiments a play is established between the coupling elements so that tiny movements between the coupling elements in a vertical and/or horizontal direction are admitted. For example, the dimension of the male part on a plane orthogonal to the respective edge is equal or slightly smaller than the dimension of the female part on the same plane. Preferably said play is greater than 0.01 mm and less than 0.15 mm, more preferably said play is comprised between 0.03 mm and 0.1 mm.

The coupling elements are configured to allow realizing a coupling by means of a movement of one floor element with respect to another adjacent floor element. Such movement may be a translational motion in a downward, e.g. vertical, direction, a translational motion in a horizontal direction, e.g. perpendicular to the edges or an angling motion around a horizontal axis parallel to the edges. Therefore, the respective motion preferably results in the aforementioned male and female parts of adjacent floor elements becoming mutually engaged. The coupling elements may be construed in accordance with several different possibilities, two of which are briefly described below. According to a first possibility, said coupling elements are configured for being coupled each other by means of an angling motion around a horizontal

axis parallel to the edges. According to this first possibility, it is also preferred that the coupling element are configured for being coupled by means of a translational motion in a horizontal direction, e.g. perpendicular to the edge.

5 According to said first possibility the male and female parts are respectively shaped in form of tongue and groove, wherein the tongue projects outwardly beyond its respective edge in a horizontal direction and the groove projects inwardly with respect to the respective edge in a horizontal direction. As already indicated above the tongue and the groove are configured in such a way that in a coupled condition of said tongue and groove the first and second locking surfaces are formed to limit relative movements of the floor elements in vertical and horizontal
10 direction, and wherein said horizontal direction is perpendicular to the edge.

According to a preferred embodiment, the tongue comprises a horizontal extending lip and a downward projecting hump. As a consequence, in this embodiment, the groove has a horizontal recess, for receiving the lip of the tongue, and an upward oriented hollow portion, for receiving the hump of the tongue, so that the tongue can be fitted into the groove. The
15 horizontally extending lip extends beyond the upper edge of the longitudinal edge. Moreover, the horizontally extending lip has a section tapered toward its tip. According to the preferred embodiment the horizontally extending lip has a maximum thickness comprised between 0.20 and 0.4 times the thickness of the board, preferably is 0.33 times the thickness of the board. In other words, the ratio between the maximum thickness of the horizontally extending lip and
20 the thickness of the board is comprised between 0.25 and 0.4 and preferably is about 0.33. Within the scope of the present application the maximum thickness is the maximum thickness of the portion of the lip that extends beyond the upper edge, for example it is measured substantially in correspondence of a vertical plane, parallel to the longitudinal edge, on which lies the upper edge. According to a preferred embodiment the maximum thickness of the lip is
25 comprised between 1 mm and 1.6 mm, preferably 1.3 mm.

According to a preferred embodiment the horizontal recess comprises one or more of the features described above with reference to the recess of the female part of the coupling element. Therefore, it is evident that by providing a horizontal recess having the enlarged inlet, opening the angling movement of the male part is eased, in particularly when the board is
30 bowed.

It is also preferred that in a coupled condition the tongue fits into the groove in such a way that a horizontal inoperative space is established between the tip of the tongue, in particular

of the lip thereof, and the bottom of the groove, in particular of the recess thereof. It is also preferred that in a coupled condition the tongue fits into the groove in such a way that a vertical inoperative space is established between the lower surface of the tongue, in particular of the lip thereof, and the groove, in particular the recess thereof. There is thus provided a tongue having a lip narrower than the groove so that the angling movement for coupling the floor elements is definitely improved. It is also preferred that in the coupled condition the downward projecting hump of the tongue contacts the hollow portion of the groove, and the upper surface of the tongue contacts the groove. In particular, it is preferred that the lower surface of the tongue contacts the groove only in correspondence of the hump. Due to this said second contact surfaces for preventing the vertical mutual movement of the floor element are provided, while coupling by angling movement is simplified because the lower contact is formed only in correspondence of the hump the tongue and not of the lip thereof.

Moreover, according to a preferred embodiment of this first possibility, in the coupled condition of the tongue and the groove is formed a play. Said play allows tiny movements in a vertical and/or horizontal direction, preferably in the horizontal direction. The play is such that the tongue and the groove can be coupled to each other without being deformed.

As a consequence of this, the effort exerted by the operator who wants to install the floor elements is significantly reduced, this is particularly important since the weight of the decorative layer if on one hand complicates the installation operations, on the other hands helps the locking between the floor elements. Therefore, a slightly slack coupling due to the play is admitted and helpful for improving the easiness of installation. Preferably said play is larger than 0.01 mm and lower than 0.15 mm, more preferably said play is comprised between 0.03 mm and 0.1 mm.

According to a second possibility, said coupling elements are configured for being coupled by means of a translational motion in a downward, e.g. vertical, direction. According to this second possibility the coupling elements comprise an upward-directed lower hook-shaped part which is situated on one edge, as well as a downward-directed upper hook-shaped part, which is situated on the opposite edge. The lower hook-shaped part defines an upward directed cavity forming a female part, whereas the upper hook-shaped part defines a downward-directed lip forming a male part. Once in a coupled position the downward-directed lip and the upward-directed cavity form the first locking surface for limiting mutual movement in a horizontal direction, e.g. perpendicular to the edge. Preferably the upper hook-shaped part

and the lower hook shaped part, more preferably respectively the lip and the cavity, are configured so that in the coupled condition the second locking surface are formed to limit the mutual movement of the floor elements in the vertical direction. Particularly, the upper hook-shaped part and the lower hook shaped part are configured so that two sets of said second locking surfaces are formed, for example on opposite of the male part and the female part. Preferably, both the upper hook-shaped part and the lower hook shaped part comprise undercut portions so that in the coupled condition the first and/or the second locking surfaces are formed to limit the mutual movement of the floor elements. Moreover, the coupling elements according to said second possibility are configured to be deformed during the coupling movement. Preferably, the lower hook shaped part comprises a flexible lever portion configured to be deformed by the coupling off the upper hook-shaped part lower hook shaped part so that by means of said deformation it is possible the coupling of the undercut portions.

It is noted that the floor element may comprise the same coupling elements, i.e. according to the first or to the second possibility, on all its edges. In particular, according to the preferred embodiment, the floor element comprises coupling elements according to the first possibility on all its edges. In this case the vertical locking between the floor elements can be very strong so to keep the levelling of the floor covering and the mechanical coupling can be particularly effective in killing or decreasing the step sound. According to alternative embodiments of the invention, the floor element can comprise coupling elements of different shapes or of different dimensions on different edges. For example, a floor element can comprise coupling elements according to the first possibility on a first couple of opposite edges, e.g. in the case of rectangular floor elements the long edges, and coupling elements according to the second possibility on a second couple of opposite edges, e.g. the short edges. In other words, a rectangular floor element can comprise coupling elements adapted for being coupled by means of an angling movement on the long edges and coupling elements adapted for being coupled by means of a translational motion in a downward direction on the short edges. Due to this solution, the coupling between the floor elements is simplified. In fact, thanks to the angling movement, for example provided by the tongue and groove, it is easy to align the long edges of the floor elements thereby simplifying the positioning and providing a strong coupling in both vertical and horizontal direction between the long edge, while the short edges can be easily coupled by means of a translational motion in a downward direction as a direct consequence of the coupling between the long edges. This is particularly advantageous in case of a heavy decorative layers, in fact once the coupling elements according to the first possibility, e.g. the

tongue and the groove on the long sides, are coupled it is sufficient to let the floor element lay in the horizontal position to realize the mechanical coupling of the coupling elements according to the second possibility, e.g. on the short edges without the need of hammering or beating the floor element itself. This happens also in case the coupling elements according to the second possibility are deformed during the coupling since the weight of the decorative layer may be sufficient to cause said deformation.

Preferably, the board is preferably made of a material adapted to be provided with coupling elements and/or made of a waterproof material and/or made of a compressible material. According to the preferred embodiment, the board is made of a polymeric material. Polymeric materials have good mechanical properties in combination with relative low cost and low weight and, further, they provide for an impermeable and a sound reducing board.

Preferably, the board is made of a thermoplastic polymeric material, preferably with a glass transition temperature (T_g) below 100°C , for example of PVC (polyvinyl chloride) or polyurethane, more particularly thermoplastic polyurethane. Examples of thermoplastic material are PVC, polyethylene, polypropylene, polyethylene terephthalate. Forming the board out of a material with a relatively low glass transition temperature leads to a board which is easily compressed at room temperature. Compression is desirable in many respects. For example, a possible thermal expansion of the board may be partially or wholly suppressed by the more rigid or stiffer decorative layer and/or reinforcing element that holds the material of the board in its original dimension. Compression is also interesting for the design of the coupling elements and allows for a certain adaptation to unevenness of the subfloor, which in its turn prevents air chambers in between the board and the subfloor that may amplify walking noises. Compression is also preferable for floor element having a significant planarity deviation since the coupling elements can more easily adapt each other in case of differences in heights.

Among thermoplastic materials, PVC is a preferred choice for the board due to the balance between processability, physical and mechanical properties and cost.

The board can be made either of a flexible or, preferably, of a rigid PVC, wherein rigid PVC comprises an amount of plasticizer lower than 15 phr, and flexible PVC comprises an amount of plasticizer of 15 phr or higher, preferably more than 20 or more than 25 phr. Within the context of the present description, "rigid" means that the board, taken alone, bends under the own weight thereof less than 10 cm per meter and still better less than 5 cm per meter, whereas the "flexible" means that the board, taken alone, bends under the own weight thereof

more than 10 cm per meter. The board may also comprise a high amount of filler materials, such as chalk, e.g. more than 30 wt% or more than 60%wt of such filler materials. The fillers add weight to the board and make the board very effective in killing the transit of walking sound to lower quarters. The content of filler should be preferably limited to below 60 wt%, preferably below 50wt% in order to avoid excessively increasing the brittleness of the board. Rigid PVC provides for a board having good dimensional stability when exposed to variation of the temperature. In other words, the expansion of the board, when exposed to high temperature, is limited thereby providing a good stability of the floor. A board made of flexible PVC has a lower dimensional stability but is more easily compressed and therefore its tendency to expand could be suppressed at least to some extent by other components of the floor elements.

According to a preferred embodiment, the board is made of a rigid PVC. Preferably the rigid PVC may comprise a flexural modulus between 1.5 and 3.5 GPa, for example, approximately 2.6 GPa. The board may also comprise a flexural strength between 60 and 90 MPa, for example approximately 76 MPa. Moreover, the board may comprise a compressive strength between 40 and 70 MPa, for example approximately 56 MPa. In fact, the inventors have found that the rigidity of the board helps absorb the impact energy thereby improving the impact strength.

According to an embodiment of the invention the board can be designed in such a way to compensate for variations of shape and/or dimension due, for example, to variations of the temperature. For example, the board can be formed of a plurality of separated elements, for example strips, or can comprises transversal notches separating adjacent portions of the board thereby permitting the expansion of said portions without affecting the global stability of the floor.

Furthermore, the board has preferably a thickness comprised between 3.2 mm and 6 mm, more preferably about 4 mm. For example, the preferred embodiment of the invention provides for a board made of rigid PVC and showing a thickness of 4 mm, thereby representing a good solution in terms of thermal stability, noise reduction, low weight and low cost.

Although according to a preferred embodiment the board comprises of polymeric material, in alternative embodiments the board may comprise other materials. In fact, with the aim of the present invention the substrate may comprise any material suitable to be used as board in furniture, wall covering or floor panel. It is also preferable that the substrate is

waterproof. For example, the substrate can comprise a cement-based material, or a mineral based material.

In the case of cement-based material the substrate may comprise a fiber containing cement board, for example portland cement board. With fiber containing cement board is
5 intended a board containing at least a cement and a fibrous material, bonded together, for example pressed together to form the board. The fibers can be for example polymeric fibers or natural fibers. The adhesion is preferably carried out under pressure either in a cold or warm condition.

In the case of mineral-based material the substrate may comprise a fiber containing
10 mineral board. With fiber containing mineral board is intended a board containing at least a mineral and a fibrous material, bonded together, for example pressed together to form the board. The mineral can comprise silica, calcium carbonate, gypsum and/or magnesium oxide. The fibers can be for example polymeric fibers or natural fibers, for example cellulose or wood fibers. The mineral-based material the substrate may comprise glass fibers, preferably non-
15 woven fiberglass. The adhesion is preferably carried out under pressure either in either in a cold or warm condition.

In the case of mineral-based material the substrate may comprises a multilayer structure. For example, the substrate can comprise a plurality of sheets or layers of mineral-based material bonded together to form the substrate. Said sheets can have the same composition or,
20 preferably, said sheets can have different compositions. For example, the substrate can comprise an upper sheet, a lower sheet and at least an intermediate sheet, wherein said upper sheet and said lower sheet can have substantially the same composition that is different from the composition of the intermediate sheet. For example, the upper and lower sheets can comprise fiberglass, and/or a higher amount of fiber, preferably natural fiber, with respect to
25 the intermediate sheet. This solution provides for an engineered substrate having the desired mechanical and physical properties, particularly thermal stability and rigidity, and a low cost due to an intermediate sheet having a cheaper composition. It is to be noted that the multilayer structure can comprise a plurality of sheets having different physical and/or mechanical characteristics. For example, said sheets can have different density and/or porosity. In a
30 preferred example, the substrate can comprise a lower and/or a top sheet with lower porosity and an intermediate sheet with higher porosity to provide waterproofness while the intermediate layer help in keeping a lower overall density of the substrate and reducing the cost of the substrate itself.

In the case of mineral-based material, examples of magnesium oxide-based boards are inter alia magnesium oxychloride-based board (Sorel cement), magnesium oxysulfate-based board and magnesium sulfate-based.

5 In the case of mineral-based material the substrate may have a density for example between 0.85 g/cm^3 and 2 g/cm^3 , for example between 0.85 g/cm^3 and 1.5 g/cm^3 .

10 It is to be noted that cement-based material and mineral-based material provides the advantage of a low flammability. Moreover, said cement-based material and mineral-based material are rigid and show a limited thermal expansion. Said thermal expansion is in fact very similar to that of stone like material, therefore the floor covering result in a highly stable floor covering. The high rigidity of the cement-based material or mineral-based material can provide an important contribution in the overall impact strength of the floor covering. Moreover, the mineral-based material shows a relatively low density, so that a floor covering resulting from the combination of a substrate made of mineral-based material and a decorative layer made of stone like material, like ceramic, provides a relatively light, and stable floor element.

15 According to a preferred embodiment of the invention, the floor element comprises a decorative layer provided above the board. Preferably the decorative layer is made of a material that is different from the material of the board. It is to be noted, the according to this preferred embodiment the coupling elements may be, preferably, wholly formed in said board. Moreover, the decorative layer can be attached to the board by means of an adhesive, preferably a resin
20 which will be described hereinafter.

The decorative layer can be made of any kind of hard or brittle material, such as ceramic, natural stone, concrete, glass or glass-ceramic material. Said brittle materials show high wear resistance, impermeability and cleanability. With brittle material is intended a material that breaks without significant plastic deformation. In particular, for the scope of said
25 patent application, with the term brittle material is intended a material that of its own (if not bonded to a board and without any reinforcing element) has an impact strength lower than 1,68J (corresponding to a ball falling from a height lower than 762 mm) according to the ball impact test described herein. Impact strength for flooring can be determined by means of a steel ball impact test. According to this test the impact strength is measured by dropping a steel ball on
30 the floor element from a certain height, if the floor element does not break the height is increased until a height is reached where the steel ball breaks the floor element. The steel ball has a weight of 225.5 grams and a diameter of 38.1 mm (1.5 inches). The impact strength is

expressed in terms of the maximum attainable height from which the steel ball, when dropped on the floor element does not break the floor element. The higher the drop height, the higher is the impact strength. The impact strength can be expressed in Joule (J), i.e. the energy of the steel ball when hitting the surface of the floor element.

5 According to a preferred embodiment the decorative layer comprises a ceramic body, for example made of porcelain, red body ceramic, stoneware, earthenware, or other sintered ceramic powders. Preferably, the decorative layer is a ceramic tile or slab. The term “ceramic tile” includes an element with a substantially flat body consisting of baked minerals, such as clay, and preferably with a fired decorative top surface, preferably but not necessarily, on the
10 basis of a glaze. The glaze has also the effect of preventing the resin permeating the decorative layer from reaching the upper surface of the decorative layer thereby affecting the appearance of the floor element.

 According to a preferred aspect of the invention the decorative layer may comprise, at least in correspondence of its lower surface, an open porosity adapted to allow the adhesive or
15 resin to permeate the decorative layer itself, thereby improving the bonding with the board. Thus, according to a preferred embodiment of the invention the decorative layer comprises an apparent porosity between 0.1% and 10% determined according to ASTM C373, more preferably between 2% and 8%, for example 6%. Since, the pores of the material, especially the closed pores, may represent weak points of the material itself, it is preferable that the
20 decorative layer comprises an apparent porosity lower than 15 %, preferably lower than 10% measured according to ASTM C373. Furthermore, the decorative layer may preferably have a volume of the open pores comprised between 0.01 cc (cubic centimeter) and 1 cc, more preferably between 0.10cc and 0.90cc, for example 0.60cc. The abovementioned ranges and values of apparent porosity provide the optimum balance between intrinsic mechanical
25 properties of the decorative layer and the resin permeability thereof thereby providing the best bonding between the resin without affecting the intrinsic mechanical properties of the decorative layer. In this way the pores are big enough to be filled by the resin while at the same time they are sufficiently small to not compromise the mechanical properties of the decorative layer. As it will be further described subsequently, by permeating the lower surface of the
30 decorative layer with the resin it is possible improve the impact strength thereof since the resin seals the pores forming a sort of polymeric-ceramic composite material and the transfer of the stress generated during the impact is significantly improved. This result is particularly impressive since the apparent porosity range is peculiar for ceramic tiles that are used mainly

for wall covering or for floor covering in residential installations, but for floor covering of commercial installations where the traffic is more intense and higher mechanical properties are required, it generally is preferred the use of ceramic tiles having lower apparent porosity. Surprisingly, the inventors have found that by permeating the lower surface of the decorative layer, a tile usually destined to wall covering or low traffic environment can achieve properties and behavior typical for high traffic floor installation. It is to be noted that said porosity and the reinforcing mechanism of the resin is effective not only for ceramic tile, which constitutes the preferred embodiment of the invention, but for any material suitable for the decorative layer as previously indicated.

10 According to a first preferred possibility for forming the ceramic tile of the decorative layer, the ceramic tile is made of porcelain. Porcelain is a ceramic material obtained by firing at high temperature, for example around 1200 °C, a mixture of relatively pure raw material comprising clays, kaolin, quartz, feldspar, calcium carbonate and/or other mineral raw materials. Porcelain shows a very low apparent porosity, preferably below 1%, for example
15 0.3% measured according to ASTM C373. Porcelain has a volume of the open pores comprised between 0.01 cc (cubic centimeter) and 0.1 cc, more preferably between 0.1 cc and 0.6cc. Said porosity values are such that the porcelain material shows relatively high mechanical properties and it can efficiently bond to the board via a resin or adhesive.

 According to a second preferred possibility for forming the ceramic tile of the
20 decorative layer, the ceramic tile is made of a red body ceramic tile. Red body ceramic is a ceramic material obtained by firing at high temperature, for example around 1150°C, of a raw material mixture comprising clays, kaolin, quartz, feldspar, calcium carbonate and/or other mineral raw materials. Red body ceramic may be fired at lower temperature with respect to porcelain thereby showing a higher porosity and water absorption rate. Moreover, red body
25 ceramic is obtainable starting from a raw material mixture that is cheaper than the raw material mixture that is necessary to obtain porcelain. For example, red body ceramic may comprise an apparent porosity less than 10%, preferably between 2% and 8%, for example 6% measured according to ASTM C373. Red body ceramic may have a volume of the open pores comprised between 0.10cc and 0.90cc, for example 0.60cc.

30 The inventors have found that the interaction between the resin or adhesive and the decorative layer is improved if the decorative layer comprises a lower surface that is substantially flat. The lower surface is the non-visible surface (in use) that is opposite to the upper decorative surface of the decorative layer. Usually, the lower surface of a ceramic tile

comprises ribs that can have a thickness up to 1 mm, but the inventors have found that for the application of the resin to the lower surface itself it is preferred to use a decorative layer that is free from said ribs. Furthermore, according to a preferred embodiment of the invention the lower surface of the decorative layer, in particular of the ceramic tile, is free from backwash.

5 The backwash is a thin coating basically comprising an engobe that is applied to the lower surface of the ceramic tile and has the function of preventing the material of the non-fired ceramic tile from sticking onto the rollers of the firing kiln. Since the backwash comprises an engobe that is at least partially composed by a glass composition, during firing of the ceramic tile it melts permeating the pores of the ceramic tile that are open on the lower surface thereof
10 so that the lower surface itself becomes impermeable. Thus, the inventors have found that a decorative layer made of a ceramic tile having a lower surface free from backwash provides a better resin permeability of the lower surface of the ceramic tile. It is also possible that the backwash covers a portion of the lower surface of the decorative layer that is lower to the 20%, preferably the 10% of said lower surface. In this way the backwash does not totally
15 impermeabilize the lower surface allowing the resin to permeate said porosity of the decorative layer, while on the other hand helps the manufacturing of the decorative layer preventing the material of the non-fired ceramic tile from sticking onto the rollers of the firing kiln.

The decorative layer has an upper face comprising a décor. The décor can be provided with a variety of textures, designs and colors. In a preferred embodiment, the décor simulates
20 a natural product, such as natural stone or wood. Preferably, the décor is at least partially formed by a print. The print is preferably realized by means of digital printing, such as inkjet printing, although screen printing, rotogravure, flexography or off-set printing is not excluded. According to another embodiment, the décor is at least partially formed by uniformly colored base material or by a mix of colored base materials.

25 The decorative layer can comprise a background coating covering at least partially its upper surface and adapted to receive the décor on its top, for example adapted to receive the print on its top. The background coating can be white, beige, brown or of any color suitable to receive a décor on its top. In the case that the decorative layer is made of a ceramic material, the background layer preferably comprises at least a glaze covering the upper surface of the
30 ceramic body.

The decorative layer can also comprise a protective coating that covers at least partially its upper surface and is adapted to be placed above the décor. The protective coating can be transparent or translucent. The protective coating can be used in combination with the

background coating. In the case that the decorative layer is made of a ceramic material, the protective layer preferably is a glaze.

It is noted that the decorative layer may comprise density as expressed by surface weight of at least 10 kg/sqm, preferably 15 kg/sqm, for example greater than 19 kg/sqm. High
5 density of the decorative layer may improve installation of the floor covering and in particular a vertical locking of between the floor elements as it will be described below in more detail. It is also preferred that the decorative layer comprises a density as expressed by surface weight of less than 35 kg/sqm, preferably less than 30 kg/sqm, for example less than 25 kg/sqm. In fact, an excessively heavy decorative layer may affect the maneuverability of the floor element
10 as well as complicating the packaging and the transportation thereof.

Preferably, the decorative layer has a thickness comprised between 4 and 15 mm, for example more than 6 mm, preferably more than 7 mm, for example about 8 or about 10 mm. Thus, the thickness of the floor element is less than 20 mm, preferably 18 mm or less, more preferably 13 mm or less. In this way, the thickness of the resulting floor element is relatively
15 thin, so that the impact of the floor in the environment is reduced, especially in case of restoration of existing flooring. Moreover, in this way, the surface weight of the floor element is limited so that the packaging, the transport and the installation are made easier. For example, the surface weight of the floor element is at least 18 kg/sqm, preferably at least 21 kg/sqm. For example, in a preferred embodiment wherein the decorative layer is made of porcelain and
20 comprises a thickness of 8.5mm and wherein the board is made of PVC and comprises a thickness of 4 mm, the surface weight of the floor element is approximatively 24 kg/sqm. Due to this there is a good balance between economy of transport and packaging and easiness of installation. In fact, a weight above said limits may help the coupling between two floor elements, especially improving a vertical locking between them.

25 The decorative layer can be made of any shape, for example a squared, rectangular or hexagonal shape. In the preferred embodiment, the floor elements are rectangular and oblong in shape, and are preferably provided with a wood grain or stone print depicting wood grain lines or stone veins extending globally in the longitudinal direction of the rectangular decorative layer.

30 Moreover, the decorative layer, especially in the case that it is made of a ceramic material, may be slightly bowed so that there may be the same issues due to irregularities of the subfloor. The larger the side of the decorative layer is, the larger said bending is so that is

preferred that the floor element, and the decorative layer, comprise a reduced superficial area. The bowing of the decorative layer is also reflected into the bowing of the whole floor element and, as already introduced, it may complicate the coupling of the floor element. Therefore according to a preferred embodiment, the decorative layer comprises a planarity deviation less than 1.5mm, preferably less than 1 mm, even more preferably less than 0.8mm. Within the context of the present application, the planarity deviation is defined as the vertical height difference between the extremal portion and the central portion of an edge of the decorative layer. In particular within the scope of the present invention the planarity deviation is measured by placing the extremes of one edge of the decorative layer, on a horizontal plane and measuring the distance between the middle of the edge from that horizontal plane. Moreover, within the context of the present application the planarity deviation is preferably measured considering the lower surface of the decorative layer. In fact, the board glued below the decorative layer acquires at least the same planarity deviation.

The floor element may comprise any dimension, although it is preferred that it comprises a superficial area of less than 1.5 sqm, preferably less than 1 sqm, more preferably less than 0.4 sqm. For example, the floor element, and in particular the decorative layer, comprises an edge having a maximum length of less than 1.5 m, preferably less than 0.9 m. In fact, the floor elements are destined to lay on a subfloor that may have irregularities like depressions or bumps that can affect the floor covering installation, the impact resistance and also the fatigue resistance of the floor elements. For floor elements having a reduced area it is reduced the effect of said irregularities as well as the probability of encounter said irregularities. Moreover, the planarity deviation is often a function of the length of the edges of the floor element, and in particular the longer the edge means that the planarity deviation could be higher. Therefore, to limit the length of the edges can prevent an excessive planarity deviation of the floor element that can complicate the coupling.

Preferably, the board has a shape basically corresponding to the decorative layer, however, preferably, with one or more portions extending beyond the decorative layer. The board may also comprise one or more recesses extending underneath the decorative layer. The board preferably is a coherent element, wherein the board preferably covers the majority, i.e. at least 50 percent, of the lower surface of said decorative layer. Preferably the board covers 80 percent or more of the lower surface of the decorative layer. According to a variant, the board comprises a plurality of separate adjacent board portions, in which case said plurality of board portions preferably covers at least 50 percent of the lower surface, or even 80 percent or

more thereof. In a coupled condition of two of said floor elements preferably an intermediate distance is available between the respective upper edges of adjacent floor elements. Preferably, the decorative layer is mounted on the board in such a way that when the floor elements are in a coupled condition said intermediate distance is available between the edges of adjacent decorative layers, while the edges of the underlying board are coupled to each other by means of the available coupling elements. Due to this solution slight dimensional variations of the decorative layer of adjacent tiles may be tolerated. In the cases where the decorative layer is formed by one or more ceramic tiles, both unrectified tiles and rectified tiles may be selected, wherein unrectified tiles are preferred since they are less expensive than the rectified ones. Even when rectified tiles would be selected, an intermediate distance of at least 1.5 millimeter, for example around 3 millimeters or more is preferred in case of unrectified tiles. In general, with brittle decorative layers, direct contact between the edges of the decorative layers of adjacent floor elements is best to be prevented in order to minimize the risk of breaking off edge portions upon installation, or upon use of the floor covering. The prevention of direct contact between the edges of the decorative layers also prevents squeaking noises from generating when the floor is walked upon. Further some decorative layers and/or boards may expand or contract due to thermal variation. The available intermediate distance prevents that such expansion and contraction affect the stability of the floor. For example, the decorative layer is mounted on the board in such a way that is centered onto an upper surface of the board, e.g. each upper edge of the board extends beyond the edge of the decorative layer of the same predetermined distance. For example, said predetermined distance is the half of the intermediate distance between the respective upper edges of adjacent floor elements in the coupled condition. This solution is especially preferred in case unrectified tiles are used because it simplifies the positioning of tiles that may have slightly different dimensions on boards having the same dimensions.

In accordance with a preferred aspect of the invention the floor element comprises an intermediate layer disposed between the decorative layer and the board. The intermediate layer preferably comprises an adhesive or a resin that bonds together the decorative layer and the board. According to the preferred embodiment the decorative layer comprises a resin, for example a thermosetting resin or thermoplastic resin. Examples of thermosetting resin are epoxy, polyurethane, unsaturated polyester, vinyl ester, cyanoacrylate. Examples of thermoplastic resin are hot melt, polyester thermoplastic, acrylic resin, vinyl etc. Preferably the resin is a rigid resin. In fact, the inventors have found that a rigid resin, rather than flexible

resin, improves the transfer of the impact energy between the layers. In particular, according to the preferred embodiment of the invention the intermediate layer comprises an epoxy resin. It is also preferred that the epoxy is a bicomponent resin, i.e. a thermosetting resin obtained by curing at low temperature (for example at room temperature) a mixture of two components, namely a resin and a hardener. When the two components of the resin are mixed together the curing reaction starts so that it is not necessary to activate the cure by providing external energy, like heat, UV or EB radiation. Said external energy could be optionally provided in order to accelerate the curing process.

Moreover, according to a preferred embodiment, the resin material permeates a lower surface of the decorative layer. In other words, the resin material penetrates the open porosity of the decorative layer. The inventors have found that, due to this solution, the impact resistance of the floor element, more particularly of the decorative layer of ceramic, is highly increased, so that, even with the mechanical locking between such floor elements, the impact strength achieves or even exceeds the impact strength of the traditional elements installed by means of adhesives. Moreover, in this way it is possible to improve the impact resistance of the floor element without the necessity to add further rigid or resilient reinforcing elements like rubber layer, fiberglass or metal plates. In fact, the resin permeating the pores of the decorative layer substantially improves the transmission and dissipation of the impact stress through the floor element so that a lower portion of said energy is absorbed by the decorative layer improving the impact resistance thereof. Since it is not necessary to add rigid reinforcing elements, the resulting floor element is lighter and thinner. Moreover, the resin constitutes a hinder to the propagation of cracks in the decorative layer itself. Furthermore, in case of superficial cracks of the decorative layer, the intermediate layer keeps the decorative layer itself coherent, and preferably compacted, thereby disguising the visual appearance of the superficial cracks.

According to a preferred embodiment the resin comprises epoxy resin. The inventors have found that the epoxy resin shows very good affinity both with the decorative layer and PVC where PVC is a material forming the board. In fact, the inventors have found that PVC shows a good affinity with epoxy resin so that it is possible to form a very good bonding and interphase between the board and the intermediate layer. This interphase improves the transfer of impact energy between the layers of the floor element thereby improving impact strength thereof. Moreover, the inventors have found that due to the interaction between PVC and epoxy resin it is possible to reduce or avoid any delamination effect between the board and the intermediate layer, and this has the consequence of improving the fatigue resistance of the floor

element. In fact, since the board and the intermediate layer are not separated from each other because of the delamination, the floor element can maintain substantially unaffected its mechanical properties even after prolonged solicitation, thereby showing good fatigue strength. Moreover, according to the preferred embodiment the decorative layer comprises a ceramic tile
5 which could be either a porcelain tile or a red body ceramic tile. In fact, a porcelain tile as such, i.e. when not bonded to a board and without the resin permeating the decorative layer, shows an impact resistance of 0.73 J, whereas a floor element comprising a decorative layer made of porcelain bonded above a board by means of an intermediate layer comprising a resin that permeates the lower surface of the decorative layer can reach an impact resistance up to 3.37J.
10 Usually a red body ceramic tile as such, i.e. when not bonded to a board and without the resin permeating the decorative layer, shows an impact resistance of 0.67 J, whereas a floor element comprising a decorative layer made of red body ceramic bonded above a board by means of an intermediate layer comprising a resin that permeates the lower surface of the decorative layer can reach an impact resistance up to 5.62J. It is to be noted that a red body ceramic tile as such
15 has an impact resistance lower than a porcelain tile as such, whereas a floor element according to the invention and comprising red body ceramic shows a significantly higher resistance than a floor element comprising porcelain.

According to a preferred aspect of the invention the resin comprises a viscosity at 20°C less than 1000 mPas, preferably less than 800 mPas, more preferably less than 600 mPas, for
20 example approximately 400 mPas. Within the scope of the invention viscosity means the viscosity of the uncured resin, for example the viscosity of the mixture of the two components before the completion of the curing, i.e. during the so-called pot life. Values of viscosity expressed in the present application are referred to dynamic viscosity and can be measure with torsional rheometer like, for example those of Anton Paar Physica MCR series. In fact, the
25 inventors have found that if the resin is sufficiently fluid, during its application onto the back of the decorative layer, it can permeate the pores thereof in order to extremely improving the bonding between the intermediate layer and the decorative layer. In practice the when the resin permeates the pores of the decorative layer it substantially forms a “composite polymer-ceramic layer” that can significantly improve the impact strength of the floor element.
30 Moreover, due to the intermediate here described it is possible improve the impact resistance and fatigue behavior of relatively thin decorative layer. It is noted that, according to a preferred solution the resin is in a substantially liquid state during the manufacturing process of the floor element. It is also possible that the resin can be in a pasty or gel state during the manufacturing

process, for example showing a thixotropic behavior in order to reach a sufficient fluidity to permeate the pores of the decorative layer under predetermined process conditions, for example during a pressing step. According to an embodiment of the invention the intermediate layer may comprise two or more different resins. For example, the intermediate layer may comprise
5 a first resin for impregnating the pores of the decorative layer and a second resin for bonding together the decorative layer and the board. According to said embodiment the first resin may be a rigid resin for reinforcing the decorative layer and the second resin may be a for example a soft or elastomeric resin that provides a cushioning effect in case of impact.

Preferably the resin may also show a shrinkage, after curing, comprised between 0.5
10 and 15% for example between 1 and 10 %. The inventors have surprisingly found that a resin showing this characteristic during its curing retires significantly. Since during curing the resin is the only component of the floor element that shrinks, it compresses the decorative layer disposed above thereby reinforcing the decorative layer itself. This effect can be further enhanced if the resin permeates the lower surface of the decorative layer. In fact, if the resin of
15 the intermediate layer permeates the lower surface of the decorative layer the strong bonding within the two layers helps the compressive action of the resin. Moreover, this reinforcing mechanism due to the compressive action of the resin may join the reinforcing action due to the filling of the pores and the improved stress transfer mechanism toward, if present, the board.

This compressive effect is evident by measuring the bowing of the floor element, i.e.
20 the planarity deviation thereof. Usually, the planarity deviation of the decorative layer is reflected into the bowing of the whole floor element and, as already introduced, it may complicate the coupling of the floor element. The inventors have found that after curing of the resin the floor element shows a planarity deviation which is higher than the planarity deviation of the sole decorative layer before application of the resin. This means that the decorative layer
25 is compressed and reinforced. Therefore, according to the preferred embodiment, after gluing, the board comprises a planarity deviation below 1.5mm, preferably below 1 mm, more preferably below 0.8mm. Within the context of the present application, the planarity deviation is defined as the height difference between the extremal portion and the central portion of an edge of the board. In particular within the scope of the present invention the planarity deviation
30 is measured by placing the extremes of one edge of the decorative layer, on a horizontal plane and measuring the distance between the middle of the edge from that horizontal plane. According to an embodiment of the invention, upon this compressive effect the planarity

deviation of the floor element after gluing is at least 1%, preferably at least 5%, for example at least 10% higher than the planarity deviation of the decorative layer before gluing.

The inventors have also found that preferably the resin may be free from fillers, like mineral fillers. In fact, the inventors have found that the presence of fillers if on one hand
5 improves mechanical properties of the resin as such, on the other hand increases the viscosity of the resin thereby forming an obstacle to the permeation of the decorative layer.

The resin preferably comprises a tensile strength between 50 and 90 MPa, more preferably between 60 and 80 MPa, for example 75 MPa. It is noted that the resin preferably
10 comprises a compressive strength between 90 and 130 MPa, more preferably between 100 and 120 MPa, for example 110 MPa. The inventors have found that such strength is sufficient to provide a rigid matrix for the composite polymer-ceramic layer that allows dissipation of the impact energy. It is also noted that the resin may preferably show a hardness value of at least 50 measured on a Shore D scale.

Preferably the resin covers at least a portion of the lower surface of the decorative layer,
15 for example the majority, i.e. at least 50 percent, of the lower surface of said decorative layer. More preferably the resin covers 80 percent or more of the lower surface of the decorative layer, for example it covers the 100 percent of the lower surface of the decorative layer so that the effect of distribution and dissipation of the impact energy is obtained for an impact occurring in any point of the decorative layer.

20 The resin is preferably provided onto the lower surface of the decorative layer in an amount more than 150 g/sqm, more preferably more than 200 g/sqm, for example 220 g/sqm so that the resin is in an amount that is sufficient to fully permeate the open pores of the lower surface of the decorative layer.

It is also preferable that the resin is provided in an amount sufficient to overflow from
25 the open porosity of the decorative layer in order to act as a glue for the board. In other words, it is preferable that the resin partially permeates the open porosity of the decorative layer and partially coats the lower surface thereof for forming the intermediate layer and improving the transfer of energy. Said effect of transfer of energy is further improved if the board is directly fixed to the intermediate layer and, in particular, to said portion of the resin that coats the lower
30 surface of the decorative layer, so that the intermediate layer acts as an adhesive layer that bonds together the decorative layer and the board.

Further, the intermediate layer may comprise a reinforcing element. The reinforcing element may be embedded into the intermediate layer, for example embedded into the resin material or may be a reinforcing layer placed between the intermediate layer and the board. The reinforcing element may comprise fibers like glass fibers carbon fibers, polymeric fibers, for example aramid or polyamide fibers, or ceramic fibers, for example boron or silicate fibers. The fibers may be woven or non-woven fibers, for example with fibers disposed at different orientations, and may be in in form of mat, fleece or cloth. Said reinforcing element may be used to further improve the impact resistance of the floor elements especially in case of special and peculiar installation like raised floors.

According to an alternative embodiment the reinforcing element may comprise a metal plate, for example a steel or aluminum plate. Preferably, the metal plate is configured to establish a compressive state in the decorative layer. In this way, since the decorative layer is in a compressive state, the impact resistance is strongly improved, because the compression obstacles the propagation of cracks and helps in disguising the visual effect of superficial cracks. To achieve this goal, the metal plate is first stretched, for example by means of a mechanical or thermal stretching, and then is bonded to the decorative layer while the metal plate is in the stretched state. Subsequently, the stretch is released, by interrupting the mechanical solicitation or by cooling the metal plate itself, thereby establishing a compressive state in the decorative layer. For example, in this embodiment, the metal plate has a coefficient of thermal expansion higher than the coefficient of thermal expansion of the decorative layer. Due to this solution, the reinforcing element is heated to a stretched state, and then it is bonded to the decorative layer while it is still in the stretched state and subsequently it is cooled down to retract and put the decorative layer in compression.

As already stated above, it is preferred that in a coupled condition, the decorative surface of two adjacent floor elements are separated by an intermediate distance. The intermediate distance, or gap, between the decorative layers of adjacent floor elements can be further finished in several possible ways.

According to a first possibility, said intermediate distance between the decorative layer can be filled by a grout thereby providing an impermeable floor covering. The grout may be a flexible or rigid grout. The grout may be polymer-based, cement-based or be based on a mixture of polymer and cement. Example of polymer-based grout are epoxy based, acrylic based, urethane based or silicone base.

In a second possibility, the decorative layer can be at least partially, preferably completely, surrounded by a gasket so that in a coupled condition of two adjacent floor elements said gasket is compressed by the decorative layer of an adjacent floor element so to form a substantially water tight connection between the floor elements.

5 It is noted that the characteristic that the floor element comprises an intermediate layer having a resin material that permeates a lower surface of the decorative layer, forms an inventive idea irrespective of the presence of a board, and in particular of a board comprising edges with coupling elements configured to realize a mechanical coupling with coupling elements of an adjacent floor element. Hence, the present invention, according to its second
10 independent aspect, relates to a floor element for forming a floor covering, wherein this floor element comprises a first decorative layer made of a ceramic material and a second layer arranged below this decorative layer, wherein the second comprises a resin material that permeates a lower surface of the decorative layer.

The inventors have found that traditional floorings, for example floorings made of
15 porcelain floor elements with a thickness of approximately 10 mm, directly glued to a subfloor, usually show impact strength comprised between 1.68 J and 2,25 J (corresponding to a ball falling from a height comprised between 762 and 1016 mm) whereas known floating floors show an impact strength usually lower than 1.12 j(corresponding to a ball falling from a height lower than 508 mm). The inventors have found that, thanks to second layer of the second
20 aspect, an impact strength above 5.62 J (corresponding to a fall of the steel ball from a height of above 2540 mm) can be achieved.

Fatigue strength for flooring is determined by means of the so-called Robinson Test according to ASTM C627. According to this test a three-wheel cart rotates about its center on top of a sample section of a tiles floor. Above each wheel is a rod along which weights can be
25 stacked. A power motor drives the assembly and the cart rotates at a rate of 15 revolutions per minute. The test is run according to a loading schedule with 14 different cycles. For each cycle, the schedule specifies a type of wheel to be used (soft rubber, hard rubber, or steel), the amount of weight to be stacked above each wheel, and the total number of cart revolutions to be executed. After the completion of each cycle, the sample floor section is visually examined.
30 The test result qualifies the floor according to the number of cycles passed without failure and indicates the following service level to which the floor is destined:

- Sample completing cycles 1 through 3 without failure: "Residential" rating;

- Samples completing cycles 1 through 6: “Light” commercial rating;
- Samples completing cycles 1 through 10: “Moderate” commercial rating;
- Samples completing cycles 1 through 12: “Heavy” commercial rating;
- Samples completing all 14 cycles without failure are assigned in “Extra heavy” commercial rating.

5

The inventors have found that due to the use of the second layer according to the second aspect of the invention, the Robinson Test can result in passing 6 cycles (Light Commercial) as minimum.

10 According to a second independent aspect of the invention the floor element may optionally comprise a third board placed below the second layer. Moreover, optionally said third board may comprise one or more of the features of the board described above in relation to the first independent aspect. Also, the decorative layer and the intermediate layer may comprise one or more of the features described above in relation to the first independent aspect.

15 As an example, a floor element according to said second independent aspect may be installed on a subfloor by means of a pressure sensitive adhesive layer, a tack fast loop fabric layer, (for example Velcro®). For example, the floor element may comprise a pressure sensitive adhesive layer placed below the second layer, for example a bi-adhesive layer covered by a covering sheet to be peeled out before installing the floor element onto the subfloor. Alternatively, the floor element may also be installed on a pressure sensitive adhesive
20 underlayment. As a further example a floor element according to said second independent aspect may be installed on a subfloor by means of a tack fast loop fabric layer (for example Velcro®). In this case the floor element may comprise a third board comprising a loop and hook fabric adapted to interlock with an underlayment of the subfloor. Moreover, for example, the floor element according to said second independent aspect may be installed on a subfloor
25 by means of magnetic means. In this case the, floor element may comprise a third board comprising a magnetic and/or ferromagnetic material suitable to interact with a magnetic and/or ferromagnetic underlayment of the subfloor.

30 It is also to be noted that the fact that after curing of the resin the tile is compressed and therefore reinforced, forms an inventive idea irrespective form the presence of a board and from the fact that the resin permeates the lower surface of the decorative layer. Thereto, the present invention, according to a third independent aspect, relates to a floor element for forming a floor covering, wherein this floor element comprises a decorative layer made of a ceramic

material and a board arranged below this decorative layer, wherein the floor element comprises a layer having a resin material disposed below the decorative layer, and wherein said resin compresses the decorative layer. In fact, the inventors have surprisingly found that if the resin during its curing compresses the decorative layer, the impact strength of the whole floor element is increased.

It is noted that the floor element according to the third aspect may comprise one or more of the features described in relation to the first and or the second aspect. In fact, although not necessary, the presence of a board and/or the fact that the resin permeates the lower surface of the decorative layer are preferable features of the third layer.

It is to be noted that the fact that the resin material may be used for forming a floor covering comprising a decorative layer, for example made of a ceramic material, and wherein the resin permeates a lower surface of the decorative layer and/or compresses the decorative layer, forms an inventive idea irrespective of the further characteristic of the floor element like, by way of example, the nature of the decorative layer and the presence of the board. Hence, for example, according to a fourth independent aspect, the invention relates to a use of a resin material for bonding together a decorative layer made of a ceramic material and a board to form a floor element. Wherein the resin material may comprise one or more of the features of the board described above in relation to the first independent aspect. Also, the decorative layer and the board may comprise one or more of the features described above in relation to the first independent aspect.

According to a fifth independent aspect of the invention, there is provided a floor covering comprising a plurality of adjacent floor elements, wherein one or more of the floor element are made according to the first, second or third aspect and wherein the floor covering comprises a grout filling an intermediate distance separating the decorative layers of the floor elements. Preferably the floor elements are separated from a subsurface, for example the subfloor, i.e. they are not bonded to the subsurface by means of adhesive or mechanical means. Due to this solution there is provided a floor covering composed of floor elements installed without using of adhesive, that shows a high satisfying impact and fatigue strength, and is totally impermeable. By means of the fifth aspect, the inventors have finally offered a solution to a long-felt need in the ceramic flooring world. They have provided an easy to be installed ceramic tile flooring, with a good impact strength and waterproofness.

According to a preferred embodiment of the invention the floor covering comprises an under-layer disposed beneath the floor elements that is configured to act as a moisture barrier. Thank to this solution it is possible to prevent the forming of mold underneath the floor elements. In combination or as an alternative to this solution, the under-layer can be configured
5 to act as a noise barrier thereby reducing the noise generated by steps on the floor.

The invention further relates to a method for manufacturing a floor element, for example the floor element according to the first second and/or third aspect of the invention. Therefore, according to a sixth independent aspect of the invention it is provided a method for manufacturing a floor element comprising the steps of: providing a decorative layer made of a
10 ceramic material; providing a board; providing a resin material for bonding the decorative layer and the board together; pressing the layers together for forming the floor element such that the resin material permeates the ceramic layer. In this way it is provided a method that allows manufacturing of floor elements to be installed on a subfloor without glue or adhesive and that shows relevant impact and fatigue resistance. Moreover, said method allows the manufacturing
15 of high resistance floor elements in a simple and effective way. In fact, since it is not necessary the use of rigid reinforcing element, the method comprise a reduced number of steps so that it is relatively quick, and it can be carried out by means of a relatively simple equipment. It is clear that the obtained floor element preferably shows the characteristic of the previously described floor elements of the invention in any of its aspects.

20 The step of providing the decorative layer may comprise a step of brushing and/or roughing the lower surface of the decorative. Said step of brushing and/or roughing has the goal of prepare the lower surface of the decorative layer to be permeated by the resin material. For example, in case the decorative layer is made of a ceramic material, said step of brushing and/or roughing aims to remove the backwash and/or the structure of the lower surface of the
25 decorative layer. In this way, any decorative layer may be used for manufacturing the floor element without being necessary to manufacture a specific decorative layer for the floor element, for example without being necessary to manufacture a ceramic tile without the backwash and without the structure on the lower surface.

According to an embodiment of the invention, the method may further comprise a step
30 of annealing the board. Said step is particularly effective in case the board comprises a polymeric material, more preferably a thermoplastic material, for example PVC. The annealing step remove internal stresses in the material of the board thereby reducing planarity deviation of the board itself. During the annealing step the board is heated up to an annealing procedure

which is preferably below the glass transition temperature of the material of the board. The annealing step can be performed at any moment prior to the step of providing the resin. It is also possible that the method comprises the step of providing an already annealed board.

As described above, the board may comprise edges provided with coupling elements.

5 Therefore, according to a preferred embodiment of the invention, the step of providing the board may comprise the step of providing a board comprising edges provided with coupling elements, i.e. the coupling elements are provided in the board during a separate process. Alternatively, the method for manufacturing the floor element may comprise a step of providing the coupling elements in the edges of the board. Said step of providing the coupling

10 elements may comprising milling, molding or other techniques. Moreover, said step of providing the coupling elements may be conducted either before or after a step of placing the decorative layer above the board, for example either before said step of providing the resin or after said step of pressing.

According to a preferred embodiment, the method may comprise a step of treating the

15 upper surface of the board. Said step of treating the upper surface of the board may comprise sanding, brushing, grinding or any other technique suitable to roughing the upper surface of the board. This could improve the bonding between the resin and the upper surface of the board and would also provide friction between the decorative layer and the board so in order to prevent sliding of the decorative layer upon the board that can otherwise occur when the resin

20 is not yet cured. In alternative embodiments, the method may comprise the step of providing a board having a roughed surface.

The step of providing the resin comprises the step of applying a non-cured resin on at least a surface of the decorative layer and/or of the board. The resin material may be provided by means of rolling, ejection from a nozzle (for example spraying), curtain or other techniques.

25 According to an embodiment of the invention the resin material is applied onto the upper surface of the board. According to an alternative embodiment the resin material is applied during multiple intermediate steps, for example a first amount of resin is applied onto the upper surface of the board in a first intermediate step and a second amount of resin is applied onto the lower surface of the decorative layer in a second intermediate step. This solution is preferred

30 especially for manufacturing floor elements wherein the intermediate layer comprises a reinforcing element, for example a fiber. In fact, in this case a higher amount of resin may be necessary and multiple steps for providing the resin may be ideal to ensure the correct gluing

between the layers, embedding of the reinforcing element and permeation of the decorative layer.

The step of providing the resin can comprise the step of mixing the components thereof, in case the resin is a bicomponent resin, for example a bicomponent epoxy. Said step of mixing
5 may be executed during, i.e. contemporarily, or shortly before the step of applying the uncured resin. In fact, often the curing of the resin is activated by the mixing of its components and as a consequence the viscosity of the resin increases. Thus, it is preferable to delay as much as possible the start of the curing reaction in order to make easier to spread the resin onto the layers' surfaces and improve the permeation of the decorative layer. For example, according to
10 a preferred embodiment of the invention, the resin is applied by means of ejection from a nozzle, for example spraying, and the components are mixed during spraying, for example substantially in correspondence of a nozzle of the equipment.

Preferably, during the pressing step it is exerted onto the layers a pressure of at least 350 kg/sqm, more preferably at least 370 kg/sqm. Said values have been found optimal to make
15 the resin permeating the decorative layer. Moreover, these values have been found optimal for allowing the resin to reach a 100% coverage of the lower surface of the decorative layer, because in certain embodiment the resin is applied according to a pattern and then spread during said pressing step. Moreover, the inventors have found that by keeping the pressure for a prolonged pressing time it is possible to improve the permeation of the decorative layer, for
20 example it is possible to obtain a higher penetration depth. Therefore, according to a preferred aspect of the invention the during the pressing step, the pressure is kept for a pressing time of more than 1 second, preferably more than 10 seconds, for example 30 seconds. This pressing time have been found optimal for allowing the resin to reach a 100% coverage of the lower surface of the decorative layer in case the resin is applied according to a pattern. Moreover,
25 especially in case of resin made of epoxy, said pressing time is sufficient for making the resin to start curing so that the decorative layer and the board at least partially adhere each other and sliding between them during transportation of the floor elements after pressing are prevented.

The step of pressing may be conducted in any suitable way for applying a pressure to the decorative layer and/or the board in order to help the resin penetrating the decorative layer.
30 Therefore, according to an embodiment of the invention the step of pressing may be a static pressing step wherein the layers enters into a mold of a static press so that is subjected to a predetermined pressure by means of a punch of the press. In this way it is possible to keep the pressure for the predetermined pressing time to improve the permeation of the decorative layer.

According to an alternative embodiment the step of pressing may be a lamination step wherein the layers runs into a laminating equipment, for example under one laminating roller or belt, or between a couple of laminating rollers, so that is subjected to a predetermined pressure. Since lamination is a continuous process it is possible to speed up the global manufacturing method while at the same time exerting a sufficient pressure onto the layers for the permeation of the decorative layer. During lamination the pressing time is function of the advancing speed of the layers, therefore the advancing speed may be regulated in order to speed up the process while at the same time a sufficient pressing time is guaranteed.

Preferably, the method comprises a step of stocking the floor elements for a stocking time in order to allow the resin to at least partially cure before being, packaged, transported and/or used in a floor covering. Preferably the stocking time is such to allow the resin to be at least 70% cured, preferably 85% cured, more preferably fully cured. For example, said stocking time is at least 0,5 h, preferably more than 1 h, for example 2 h.

According to an embodiment of the invention during the step of stocking the floor elements, the floor elements are stacked one above the other. This is to prevent delamination between the decorative layer and the board when the resin is not yet sufficiently cured. In fact, in this way the decorative layer and the board of one floor element are kept in contact by the weight of the floor elements disposed above. This is especially the case when the decorative layer comprises a significant planarity deviation, especially when measured on the back side. Another possibility for preventing delamination could be a step of applying a fast curing resin before the step of pressing. This fast curing resin can be for example acrylic resin or cyanoacrylates or hot melt resin. Said fast curing resin can constitute the resin of the intermediate layer or be applied in addition to the resin of the intermediate layer, for example in a smaller amount. For example, said fast curing resin can be provided according to a pattern or in dots, for example at least one dot in a central or a peripheral portion of the decorative layer, preferably in form of dots in at least two opposites corners of the decorative layer. In this way the fast curing resin immediately cures and stick together the decorative layer and the board thereby preventing delamination. The fast curing resin may further prevent sliding of the decorative layer above the board that could otherwise occur after pressing during moving of the floor elements, for example exiting of the press, if the resin of the reinforcing layer is not yet cured.

According to an embodiment of the invention, the method comprises a step of compressing the decorative layer. Said step of compressing, preferably substantially coincide

with the curing of the resin. For example, the compressing step may coincide with the stocking step.

In fact, the inventors have found that with resins showing the features described with reference to the first aspect of the invention, since during curing the resin is the only component
5 of the floor element that shrinks, it compresses the decorative layer disposed above thereby reinforcing the decorative layer itself. This effect can be further enhanced if the resin permeates the lower surface of the decorative layer. In fact, if the resin of the intermediate layer permeates the lower surface of the decorative layer the strong bonding within the two layers helps the compressive action of the resin. Moreover, this reinforcing mechanism due to the compressive
10 action of the resin may join the reinforcing action due to the filling of the pores and the improved stress transfer mechanism toward, if present, the board.

This compressive effect is evident by measuring the bowing of the floor element, i.e. the planarity deviation thereof. Usually, the planarity deviation of the decorative layer is reflected into the bowing of the whole floor element and, as already introduced, it may
15 complicate the coupling of the floor element. The inventors have found that after curing of the resin the floor element shows a planarity deviation which is higher than the planarity deviation of the sole decorative layer before application of the resin. This means that the decorative layer is compressed and reinforced. According to an embodiment of the invention, upon this compressive effect the planarity deviation of the floor element after gluing is at least 1%,
20 preferably at least 5%, for example at least 10% higher than the planarity deviation of the decorative layer before gluing.

There to according to a seventh independent aspect of the invention it is provided a method for manufacturing a floor element comprising the steps of: providing a decorative layer made of a ceramic material; providing a board; providing a resin material for bonding the
25 decorative layer and the board together; cure the resin; promote the shrinkage of the resin. It is noted that the method may comprise one or more of the features described in relation to the sixth aspect, as well as the decorative layer, the resin and the board show one or more of the features described in the aspects from the first to the fifth.

It is to be noted that in order to simplify installation of the floor covering comprising
30 the floor elements according to the anyone from the first to the third aspects, one or more tools may be used.

Therefore according to an eighth independent aspect is provided a first tool suitable for installing a floor covering having floor elements, wherein the floor elements comprise a decorative layer and a board disposed below the decorative layer and wherein the board having edges provided with coupling elements adapted to cooperate with coupling elements of an adjacent similar floor element in said floor covering, wherein the first tool comprises a body having first beating surface adapted to contact a surface of the decorative layer, and at least a second beating surface adapted to be hammered. In this way, in case it is needed to force the coupling between the floor elements, it is possible to use a hammer and exert the necessary force without breaking the decorative layer because said force is dampened and transferred to the decorative layer by the first beating surface.

In one embodiment the first beating surface is adapted to contact the surface of an edge of the decorative layer, for example the first beating surface is adapted to be placed vertical in use, and, preferably, said first beating surface has a vertical dimension (in use) substantially equal or lower than the thickness of the decorative layer, for example said vertical dimension is less than 15 mm, preferably less than 10 mm, for example about 8 mm. In this way the first beating surface can transfer to the decorative layer horizontal forces exerted to move horizontally the floor element and effecting the coupling via a translational horizontal movement. By way of example, this operation is performed to couple the transversal edges of two floor elements on a same row that is parallel to the longitudinal edges of the floor elements, once one longitudinal edge of the floor elements to be moved is already coupled with a third-floor element on a parallel row.

In one embodiment the first beating surface is adapted to contact the top surface of the decorative layer, for example the first beating surface is adapted to be placed vertical in use. In this way the first beating surface can transfer to the decorative layer vertical forces exerted to move horizontally the floor element and effecting the coupling via a translational vertical movement. This is particularly the case when the coupling elements are adapted to be coupled via a translational vertical movement.

In one embodiment, the first tool may comprise a plurality of said first beating surfaces. For example, the first tool may comprise a plurality of said first beating surfaces adapted to contact the surface of an edge of the decorative layer, for example a couple of said first beating surfaces adapted to contact the surface of an edge of the decorative layer wherein said two first beating surfaces are orthogonal each other so that the first tool may be disposed contact and angle portion of the decorative layer. In this way, while hammering to push the floor element

along a direction which is perpendicular to an active first beating surface, the orthogonal second first beating surface is substantially inactive but helps keeping aligned the floor element to be moved. Alternatively, the first tool may comprise one or more of said first beating surfaces adapted to contact the surface of an edge of the decorative layer, and one first beating surface is adapted to contact the top surface of the decorative layer.

In one embodiment, the first beating surface may comprise a dampening element adapted to dampen the force exerted by the hammer to reduce the risk of breaking the decorative layer. For example, the dampening element can comprise a soft coating of the first beating surface. For example, said soft coating may be made of rubber or a textile like felt. This solution is particularly effective in case the decorative layer comprises a ceramic tile, and in particular in case the ceramic tile is glazed. In fact, the glaze, being a glassy material, is particularly fragile and can break or crack because of the force exerted by the hammer.

The second beating surface is preferably, although not necessarily, parallel to the first beating surface. Moreover, the first tool comprises at least one second beating surface for each first beating surface. In a preferred embodiment, the second beating surface is provided on the same body portion of the first tool and is opposite to the first beating surface. Within the scope of the present application “opposite on the same body portion” means that exist one straight line that is orthogonal to both the first beating surface and the correspondent second beating surface. According to an alternative embodiment, the second beating surface may be provided on a different body portion of the correspondent first beating surface, for example they may be not opposite each other. Within the scope of the present application “not being opposite on different body portion” means that there is not one straight line that is orthogonal to both the first beating surface and the correspondent second beating surface. This solution is particularly effective when it is needed to hammer a floor element in a position of the room where the operation is difficult for the limited space, for example close to a wall.

The first tool may further comprise a handle portion to simplify its handling.

In a preferred embodiment, the first tool is made of at least a polymeric material, preferably a thermoplastic material, for example polycarbonate (PC), poly methyl methacrylate (PMMA acrylic), polyethylene (PVC), polypropylene (PP), PVC, PET, ABS, PA.

According to a ninth independent aspect there is provided a second tool suitable for installing a floor covering having floor elements, wherein the floor elements comprise a board having edges provided with coupling elements adapted to cooperate with coupling elements of

an adjacent similar floor element in said floor covering, wherein the second tool comprises an handle portion and a plane portion provided with at least one edge and wherein said edge is provided with a coupling element to be coupled with at least one coupling element of the board. This tool is particularly useful to couple the transversal edges of two floor elements on a same row that is parallel to the longitudinal edges of the floor elements. In this case the second tool may be coupled to the longitudinal edges, via its coupling element, of both the floor elements so that during the translational horizontal movement to couple the transversal edges it guides said translational movement along the horizontal direction.

Preferably the plane portion of the second tool comprises coupling elements on each of its opposite edges. For example, a male coupling element along a first edge and a female coupling element along a second coupling edge.

In a preferred embodiment, the second tool, and in particular at least the handle thereof, is made of at least a polymeric material, preferably a thermoplastic material, for example polycarbonate (PC), poly methyl methacrylate (PMMA acrylic), polyethylene (PVC), polypropylene (PP), PVC, PET, ABS, PA.

According to an embodiment of the invention the plane portion can be made of the same material of the board and can be attached to the handle.

As described above a hammer can be used for installing the covering elements. The inventors have found that by using an electric and/or automatic hammer installation is made exceptionally simple, fast and risk of damage of the decorative layer is extremely reduced. In fact, an automatic and/or electric hammer provide a more accurate control of the impulse to be transferred to the decorative layer. This impulse can be further reduced by using the first and/or second tool described above. Moreover, by using the automatic and/or electric hammer it is possible to substitute one or a few impulses at high and irregular intensity, with a plurality of impulses at regular low intensity that are exerted at high frequency. To this aim, the hammer may comprise a control unit adapted to control and/or manage the intensity and/or the frequency of an impulse to be exerted on said floor element.

The automatic and/or electric hammer comprises a body adapted to be handed by at least an operator, and a motor or operating element being adapted to activate an operative end of the hammer. Said operative end can be preferably a plate shaped or comprising a surface adapted to cooperate with a surface of the covering element, and/or with the second beating surface of the first and/or the second toll. It is also possible that the first tool and or the second

tool are mechanically connectable, preferably via a mechanical locking element, to the automatic and/or electric hammer in order to form a unique tool for installing the floor covering. In this case it is to be noted that the fact the automatic and or electric hammer comprises an operative end, said operative end comprising a beating surface adapted to contact a surface of the decorative layer form an inventive idea irrespective of all the other independent aspect of the invention. In this case the operative end of the hammer is in fact substituted by the first and/or the second tool and can comprise one or more of the features described in connection with the ninth or eighth independent aspect. It is also to be noted that, in this case, the second beating surface of the first or second tool can be substantially substituted by said mechanical locking element. Further the operative end can be removably mechanically locked to the body of the hammer so that it can be substituted and the operator can exchange an operative hand having the features of the first tool with an operative end having the feature of the second tool.

It is to be noted that the invention also relates, according to a tenth independent aspect, to a kit comprising one or more first tool, and/or one or more second tool, and/or one or more automatic and/or electric hammer. Wherein the first tool and the second tool comprise one or more of the features described with reference to the eight and the ninth independent aspect respectively.

It is also to be noted that floor element mentioned within said eight, ninth and tenth independent aspect may comprise may have one or more of the features described in the first, second and third independent aspect.

The fact that the floor element comprises a board having a coupling element and that it is made of a cement-based or a mineral-based material and having a decorative layer provided on the board, forms an inventive concept that is independent to other characteristics of the floor element, in particular of the coupling elements. Thereto an eleventh independent aspect of the invention further provides for a floor element for forming a floor covering, wherein the floor element comprises edges provided with coupling elements adapted to cooperate with coupling elements of an adjacent similar floor element in said floor covering, wherein said floor element has a decorative layer provided above a board, wherein said decorative layer comprises a brittle material, for example ceramic, porcelain, natural stone, concrete, glass or glass-ceramic material, and wherein the board comprises a cement-based material, or a mineral based material, preferably a mineral-based material comprising magnesium, more preferably magnesium oxide. This solution provides for a floor element having a decorative layer with

high aesthetical value that can be easily installed thank to the coupling elements and with a board that is rigid, thermally stable, waterproof, that provides an important contributes in the overall impact strength of the floor covering and with a relatively low weight. It is to be noted that the rigidity of the board further improves the fatigue resistance of the floor covering.

5 Moreover, this solution provides for an easily installable floor element that is completely fireproof. The floor element according to the eleventh aspect can comprise any of the features described in relation to any of the first to tenth aspects. A floor covering comprising a plurality of floor element according to the eleventh aspect can form an independent solution itself.

10 With the intention of better showing the characteristics of the invention, in the following, as an example without any limitative character, several preferred forms of embodiments are described with reference to the accompanying drawings, wherein:

Figure 1 shows a top view of a first embodiment of a floor element of the invention;

Figure 2 on a larger scale shows a cross section along the line II-II of Figure 1;

Figure 3 on a larger scale shows a view on the area F3 indicated on Figure 2;

15 Figure 4a and 4b on a larger scale respectively show a view of the areas F4a and Fb indicated on Figure 2;

Figure 5 on a smaller scale shows a top plane view of a floor covering comprising a plurality of the floor elements of Figure 1;

Figure 6 on a larger scale shows a cross section along the line VI-VI of Figure 5;

20 Figure 7 on a larger scale shows a view on the area F7 indicated on Figure 6;

Figure 8 show a schematic side view of a floor element of Figure 1;

Figure 9 on a smaller scale shows a top plane view of a floor covering comprising a plurality of the floor elements according to a second embodiment of the invention;

Figure 10 on a larger scale shows a cross section along the line X-X of Figure 9;

25 Figure 11 on a larger scale shows a view on the area F11 indicated on Figure 10;

Figure 12 shows some steps of a method for manufacturing a floor element.

Figure 13 shows a top plane view of a kit for installing the floor elements for forming the floor covering.

Figure 14 on a larger scale shows a cross section of a first embodiment of a first tool of the kit along the line XIV-XIV of Figure 13.

Figure 15 on a larger scale shows a cross section of an alternative embodiment the first tool of the kit along the line XV-XV of Figure 13.

5 Figure 16 on a larger scale shows a cross section of the second tool along the line XVI-XVI of Figure 13.

Figure 1 shows a top view of a first embodiment of a floor element 1 according to the invention. The floor element 1 comprises a decorative layer 2 disposed above a board 3.

10 As illustrated, the floor element 1 comprises a rectangular elongated shape. Preferably, the floor element 1 comprises a superficial area of less than 1.5 sqm, preferably less than 1 sqm, more preferably less than 0.4 sqm. For example, the decorative layer 2 comprises edges having a maximum length L of less than 1.5 m, preferably less than 0.9 m.

15 The decorative layer 2 has an upper face 4 comprising a décor 5. The décor 5 can be provided with a variety of textures, designs and colors. In the illustrated example the décor 5 simulates a wood pattern comprising wood nerves and flakes. Preferably, the décor 5 is at least partially formed by a print 6. The print 6 is preferably realized by means of digital printing, such as inkjet printing, although screen printing, rotogravure, flexography or off-set printing is not excluded.

20 Figure 2 on a larger scale shows a cross section along the line II-II of Figure 1. According to the illustrated example the decorative layer 2 comprises a body 7 made of a ceramic material, for example red body ceramic or porcelain.

25 The decorative layer 2 comprises a background coating 8 covering at least partially the upper surface of the body 7, for example comprising at least a glaze. The background coating 8 is adapted to receive the décor 5 on its top, for example adapted to receive the print 6 on its top. The background coating 8 can be white, beige, brown or of any color suitable to receive the décor 5 on its top.

The decorative layer 2 further comprises a protective coating 9 covering at least partially the upper surface of the body 7, for example comprising at least a glaze. The protective coating 9 is adapted to be placed above the décor 5 and is transparent or translucent.

30 Figure 2 also shows that decorative layer 2 has a thickness T1 comprised between 4 and 15 mm, for example 6 mm, preferably greater than 7 mm, for example 8 mm or 10 mm.

The board 3, according to the example, is made of a polymeric material, preferably a thermoplastic material like PVC. In a preferred embodiment, the board is made of a rigid PVC. Within the context of the present description, “rigid” means that the board, taken alone, bends under the own weight thereof less than 10 cm per meter and still better less than 5 cm per meter.

5 The board 3 may also comprise a high amount of filler materials, such as chalk, e.g. more than 30 wt% or more than 60%wt of such filler materials.

Moreover, according to a preferred embodiment, the board 3 is made of a rigid PVC that may comprise a flexural modulus between 1.5 and 3.5 GPa, for example, approximately 2.6 GPa. The board 3 may also comprise a flexural strength between 60 and 90 MPa, for example approximately 76 MPa. Moreover, the board 3 may comprise a compressive strength
10 between 40 and 70 MPa, for example approximately 56 MPa.

Furthermore, the board 3 preferably has a thickness T2 comprised between 2 mm and 7 mm, preferably below 6 mm, for example about 4 mm.

Figure 2 also shows that the board 3 comprises longitudinal edges 10 provided with
15 first coupling elements 11,12 configured to realize a mechanical coupling with coupling elements 11,12 of an adjacent floor element 1. In the illustrated examples the coupling elements 11,12 comprise a male and female parts disposed on opposite longitudinal edges 10.

The first coupling elements 11,12 of the longitudinal edges 10 are configured for being coupled each other by means of an angling motion around a horizontal axis parallel to the
20 longitudinal edges 10. The male and female parts are respectively shaped in form of a tongue 11 and a groove 12 wherein the tongue 11 projects outwardly beyond its respective longitudinal edge 10 in a horizontal direction X and the groove 12 projects inwardly with respect to the respective longitudinal edge 10 in said horizontal direction.

The board 3 extends beyond longitudinal edges 13 of the decorative layer 2. In the
25 example, the board 3 comprises upper longitudinal edges 14 that extend beyond the longitudinal edge 13 of the decorative layer 2 of a distance DI. Said distance DI is equal on both the opposite longitudinal edges 13 of the decorative layer 2.

Figure 2 further shows that the floor element 1 comprises an intermediate layer 15
30 disposed between the decorative layer 2 and the board 3. The intermediate layer 15 comprises a resin material, for example a thermosetting resin or thermoplastic resin. Examples of thermosetting resin are epoxy, polyurethane, cyanoacrylate, unsaturated polyester, vinyl ester or acrylic resin. Examples of thermoplastic resin are hot melt, polyester thermoplastic, vinyl

etc. Preferably the resin is a rigid resin. In particular, according to a preferred embodiment of the invention the intermediate layer 15 comprises an epoxy resin. It is also preferred that the epoxy is a bicomponent resin, i.e. a thermosetting resin obtained by curing at low temperature (for example at room temperature) a mixture of two components, namely a resin and a hardener.

5 The resin preferably comprises a tensile strength between 50 and 90 MPa, more preferably between 60 and 80 MPa, for example 75 MPa. Moreover, the resin preferably comprises a compressive strength between 90 and 130 MPa, more preferably between 100 and 120 MPa, for example 110 MPa. It is also preferable that the resin shows a hardness value of at least 50 measured on a Shore D scale.

10 As illustrated the intermediate layer 15 covers the 100 percent of the lower surface of the decorative layer 2. The resin is preferably provided onto the lower surface of the decorative layer 2 in an amount above 150 g/sqm, more preferably above 200 g/sqm, for example 220 g/sqm.

15 In a preferred example illustrated in figure 2, the intermediate layer 15 is in direct contact with the upper surface of the board 3 so that act as a glue between the decorative layer 2 and the board 3.

20 Figure 3 on a larger scale shows a view on the area F3 indicated on Figure 2. As illustrated in figure 3 the decorative layer 2, more in detail the body 7 thereof, comprises, at least in correspondence of its lower surface, an open porosity 16 adapted to be permeated by the resin of the intermediate layer 15.

25 Thus, according to a preferred embodiment of the invention, the decorative layer 2 comprises an apparent porosity between 0.1% and 10% determined according to ASTM C373, more preferably between 2% and 8%, for example 6%. Furthermore, the decorative layer 2 may preferably have a volume of the open pores 16 comprised between 0.01 cc (cubic centimeter) and 1 cc, more preferably between 0.10cc and 0.90cc, for example 0.60cc.

30 Therefore, in order to properly flow into said open pores 16 the resin of the intermediate layer 15 comprises a viscosity at 20°C less than 1000 mPas, preferably less than 800 mPas, more preferably less than 600 mPas, for example approximately 400 mPas. Within the scope of the invention “viscosity” means the viscosity of the uncured resin, for example the viscosity of the mixture of the two components before the completion of the curing, i.e. during the so-called pot life.

Figure 4a and Bb show on a larger scale a view on the areas F4a and F4b indicated on Figure 2.

Figure 4a shows in more detail the tongue 11 which comprises a horizontally extending lip 17 and a downward projecting hump 18. The horizontally extending lip 17 extends beyond the upper edge 14 of the longitudinal edge 10. Moreover, the horizontally extending lip 17 has a section tapered toward its tip. According to the preferred embodiment the horizontally extending lip 17 has a maximum thickness LT comprised between 0.20 and 0.4 times the thickness T2 of the board 3, preferably is 0.33 times the thickness T2 of the board 3. In other words, the ratio between the maximum thickness LT of the horizontally extending lip 17 and the thickness T2 of the board 3 is comprised between 0.25 and 0.4 and preferably is about 0.33. Within the scope of the present application the maximum thickness LT is the maximum thickness of the portion of the lip 17 that extends beyond the upper edge 14, for example it is measured substantially in correspondence of a vertical plane, parallel to the longitudinal edge 10, on which lies the upper edge 14. According to the preferred embodiment the maximum thickness LT of the lip 17 is comprised between 1 and 1.6 mm, preferably 1.3 mm.

Figure 4b shows in more detail the groove 12 which has a horizontal recess 19, for receiving the lip 17 of the tongue 11, and an upward oriented hollow portion 20, for receiving the hump 18 of the tongue 11, so that tongue 11 can be fitted into the groove 12.

The horizontal recess 19 comprises an inlet opening 21 having a vertical breadth VB which is at least 0.4 times the thickness T2 of the board 3, preferably more than 0.45 times, more preferably more than 0.5 times, even more preferably about 0.53 times. In other words, the ratio between the vertical breadth VB and the thickness T2 of the board is more than 0.4, preferably more than 0.45, more preferably more than 0.5, even more preferably about 0.53. Preferably, the ratio between the vertical breadth VB and the thickness of the board is comprised between 0.4 and 0.7, preferably between 0.5 and 0.6.

It is to be noted that the vertical breadth VB of said inlet opening 21 is preferably measured substantially on the vertical plane on which lies the upper edge 14 of the longitudinal edge 10. It is also to be noted that preferably the vertical breadth VB of the inlet opening 21 may correspond to the maximum breadth of the recess 19 of the groove 12. According to the preferred embodiment of the invention, the vertical breadth VB is greater than 1.6 mm, preferably greater than 1.8 mm, more preferably greater than 2 mm.

Moreover, between the upper border of the inlet opening 21 of the recess 19 and the upper edge 24 of the longitudinal edge 10 is provided a separating distance SD. The ratio between said separating distance SD and the thickness T2 of the board 3 can be below 0.2, preferably below 0.15. For example, said ratio between said separating distance SD and the thickness T2 of the board 3 can be comprised between 0.2 and 0.1. For example, said separating distance SD can be less than 0.9 mm, preferably less than 0.6mm. For example, said separating distance can be comprised between 0.9 and 0.4 mm.

Figure 4b also shows that the recess 19 may comprise a first portion 22 close to the inlet opening 21 and a second portion 23 close to the bottom of said recess 19. Preferably said first portion 22 comprises an inclined upper surface 24 descending toward the bottom of the recess, i.e. descending toward the second portion. Said inclined upper surface 24 is inclined with respect to the horizontal (preferably with respect to the upper surface of the board 3) of an angle α comprised between 30° and 50° , for example about 45° . The transition between the first and the second portion 22,23 substantially coincides with a change in the inclination of said inclined upper surface 24, in particular when said angle α diminishes. It is to be noted that said first portion 22 is larger than the second portion 23, wherein with larger it is meant with respect with the vertical dimension of the recess 19. Said first portion 23 may extends toward the bottom of the recess 19 for a deepness DE that is at least 0.3 times the whole maximum deepness of the recess 19, i.e. the sum of the deepness the first and the second portion 22,23. Preferably, the deepness DE of the first portion 22 is at least 0.4 times, more preferably at least 0.5 times (i.e. at least the half) of the whole maximum deepness of the recess 19. Said deepness shall be measured starting from the inlet opening 21, i.e. from substantially form a vertical plane parallel to the longitudinal edge 10 and on which lies the upper edge 14 of the longitudinal edge 10. Therefore, the deepness DE of the first portion 22 is measured starting from the inlet opening until the transition between the first and the second portion 22,23. Whereas the whole maximum deepness of the recess is measured starting from the inlet opening 21 until bottom of the recess 19. According to a preferred embodiment said deepness DE of the first portion 22 is more than 0.5 mm, preferably more than 0.75 mm, for example more than 1mm. For example, said deepness DE of the first portion 22 is comprised between 0.5 and 1.5 mm, preferably between 0.75 and 1.25 mm.

Figure 5 is a top plane view of a floor covering 25 comprising a plurality of floor elements 1 of Figure 1 coupled by means of the first coupling elements 11,12 along the longitudinal edges 10 and by means of second coupling elements 26,27 along transversal edges

28 of the board 3. It is to be noted that in the preferred embodiment shown on Figures 1 and 5 the second coupling elements 26,27 are similar to the first coupling elements 11,12 described above. Within the scope of the present invention, with "similar" it is to be understood that the second coupling elements 26,27 are configured for being coupled each other by means of an angling motion around a horizontal axis parallel to the transversal edges 28. Moreover, with "similar" it is meant that the second coupling elements 26,27 are respectively shaped in form of a tongue 26 and a groove 27. It is also preferable, although not necessary, that the second coupling elements 26,27 comprise substantially the dimensions described for the firsts coupling elements 11,12. Therefore, they are neither shown nor described in further detail.

Figure 6 on a larger scale shows a cross section along the line VI-VI of Figure 5. The floor covering 25 comprises a grout 29 filling an intermediate distance I that separates the decorative layers 2 of the floor elements 1. According to the illustrated example, the intermediate distance I is twice the distance DI between the upper edge 14 of the board 3 and the edge 13 of the decorative layer 2.

The grout 29 may be a flexible or rigid grout. The grout 29 may be polymer-based, cement-based or be based on a mixture of polymer and cement. Example of polymer-based grout are epoxy based, acrylic based, urethane based, silicone based. In the preferred embodiment the grout 19 is a flexible and acrylic based.

Figure 6 further shows a section of the mechanical coupling between the firsts coupling elements 11,12 along a plane transversal to the longitudinal edges 10. Said mechanical coupling between the firsts coupling elements 11,12 is described in detail with the aid of Figure 7.

In the coupled condition shown in Figure 7 the upper edges 14 of the boards 3 contact each other thereby forming a first set of first locking surfaces 30 limiting the mutual movement of said floor elements 1 in a horizontal direction X perpendicular to the coupled longitudinal edges 10.

Figure 7 also shows that in said coupled condition, the lip 17 is received by the recess 19. The upper surface of the lip 17 contacts an upper wall of the recess 19, in particular of the second portion 23 thereof, thereby forming a first set of second locking surfaces 31 that limit the mutual movement of said floor elements 1 in a substantially vertical direction Y. It is noted that between the tip of the lip 17 and the bottom of the recess 19 is established a horizontal inoperative space S1. Moreover, between lower surface of the lip 17 and the recess 19 is established a vertical inoperative space S2.

The downward projecting hump 18 of the tongue 11 is received by the hollow portion 20 of the groove 12. The lower surface of the downward projecting hump 18 contacts said hollow portion 20 so that a second set of second locking surfaces 31 is formed. In other words, the lower surface of the tongue 11 contacts the groove 12 exclusively in correspondence of the downward projecting hump 18.

In the coupled condition of Figure 7, between the projecting hump 18 and the hollow portion 20 is formed a horizontal play P that allows tiny horizontal movement of the tongue 11 into the groove 12. Said play P and said tiny horizontal movements are limited by a set of first contact surface that may be formed between the projecting hump 18 and the hollow portion 20.

Preferably, said play P is larger than 0.01 mm and lower than 0.15 mm, more preferably said play P is comprised between 0.03 and 0.1 mm.

It is noted that in the coupled condition the tongue 11 and the groove 12 are in an undeformed condition. Further, the whole angling movement that allows the coupling between the tongue 11 and the groove 12 occur without deformation of the first coupling elements 11,12. In fact due to the play P and the inoperative spaces S1, S2 the coupling between the tongue 11 and the groove 12 is significantly simplified.

It is also evident that due to the wide vertical breadth VB the insertion of the lip 17 into the recess 19 is simplified even in case the lip 17 and the groove 20 are not perfectly aligned along the longitudinal edges 10, wherein with "aligned" it is meant that they are not on the same plane. This is, for example, the case shown in Figure 8 wherein the floor element 1, and in particular the board 3 shows a planarity deviation PD above 0.1 mm, for example above 0.4 mm. It is anyway preferable that the planarity deviation PD is below 1.5 mm, more preferably below 1 mm, even more preferably below 0.8mm. Within the scope of the present invention the planarity deviation PD is measured by placing the extremes of one edge 10, 28 of the floor element 1, for example of the board 3, on an horizontal plane HP and measuring the distance between the middle of the edge 10,28 from that horizontal plane HP. In case the floor element 1 is rectangular and oblong the planarity deviation PD is higher along the longitudinal edges 10. Figure 8 shows a floor element 1 wherein the planarity deviation has been highly enhanced and is not in scale to help the description and explanation. Considering a floor covering with an offset installation (Figure 5) having the floor elements 1 showed in Figure 8 it is evident that the longitudinal edges 10 of two adjacent floor elements 1 to be coupled each other do not lay on the same horizontal plane. Therefore, the recess 19 with a vertical breadth VB as

described above improves the insertion of the lip 17 into the recess 19 even in case of relevant planarity deviation PD.

Figure 9 is a top plane view of a floor covering 25 comprising a plurality of floor elements according to an alternative embodiment. This alternative embodiment differs from
5 the first embodiment described above only in that it comprises second coupling elements 32,33 at the transversal edges 28 different from the first coupling element 11,12 at the longitudinal edges.

Figure 10 on a larger scale shows a cross section along the line X-X of Figure 9. Figure
10 shows a section of the mechanical coupling between the second coupling elements 32,33 along a plane transversal to the transversal edges 28. Said mechanical coupling between the
10 second coupling elements 32,33 is described in detail with the aid of figure 11.

In this second embodiment, the second coupling elements 32,33 of the transversal edges
28 are configured for being coupled each other by means of a translational movement along a substantially vertical direction. In the illustrated examples, said second coupling element 16,
15 17 are configured for being coupled by means of a translational motion in a downward, e.g. vertical, direction Y.

Figure 11 on a larger scale shows a view on the area F11 indicated on Figure 10.

The second coupling element elements 32,33 comprise downward-directed upper hook-shaped part 32 that is situated on one transversal edge 28 and an upward-directed lower hook-shaped part 33, which is situated on the opposite edge 28. The lower hook-shaped part 33
20 defines an upward directed cavity forming a female part, whereas the upper hook-shaped part 32 defines a downward-directed lip forming a male part.

Once in a coupled position the upper edges 14 of the transversal edges form the first locking surface 30 for limiting mutual movement of the floor elements 1 in a horizontal
25 direction Z perpendicular to the transversal edge 28.

Moreover, both the upper hook-shaped part 32 and the lower hook shaped part 33 comprise undercut portions 34 so that in the coupled condition the second locking surfaces 31 are formed to limit the mutual movement of the floor elements 1 in the vertical direction Y. More in particular, two sets of said second locking surfaces 31 are formed, for example on
30 opposite sides of upper hook-shaped part 32 and the lower hook shaped part 33.

Preferably, the lower hook shaped part 33 comprise a flexible lever portion 35 configured to be deformed by the coupling of the upper hook-shaped part 32 with the lower hook shaped part 33 so that by means of said deformation it is possible the coupling of the undercut portions 34.

5 It is to be noted that below the undercut portion 34 of the lower hook shaped part 33 are defined recess having a vertical inlet 21 opening that could comprise a vertical breadth VB having the dimension described above in relation to the first coupling element of the first embodiment. In this second embodiment, the second coupling elements 32,33 does not show said dimensions since the planarity deviation on the transversal edge is generally neglectable
10 with respect to the planarity deviation PD of the longitudinal edge 10.

Figure 12 shows some steps of a method for manufacturing a floor element. The method comprises a first step S1 of providing the decorative layer 2. In the step S1 the decorative layer 2 is provided into a resin application station 40 wherein the uncured resin material R is provided, for example according to a pattern, onto a lower surface of the decorative layer 2.
15 The uncured resin R preferably comprises a viscosity at 20°C lower than 1000 mPas, preferably less than 800 mPas, more preferably less than 600 mPas, for example approximately 400 mPas. It is noted that in the resin application station 40 the decorative layer is placed with the upper surface, comprising the décor 6, facing down.

Then, in a step S2 the decorative layer 2 is carried into a placing station 41 wherein the
20 board 3 is provided. The board 2 is placed below the lower surface decorative layer 3 thereby forming a semi-finished sandwich 42. Preferably, in said placing station 41 the decorative layer 2 and the board 2 are properly centered with respect to each other.

Successively, in a step S3 the semi-finished sandwich 42 is carried into a pressing station 43 wherein the layers 2,3 are pressed together for forming the floor element 1 such that
25 the resin material permeates the pores of the ceramic material of the decorative layer 2 and forms the intermediate layer 15. Preferably, the pressure is kept for a pressing time of at least 1 second, preferably 30 seconds so that the uncured resin R can flow covering, at least the 80 %, preferably the 100% of the lower surface of the decorative layer 2. Moreover, said pressing time is necessary to let the uncured resin R permeates the decorative layer 2. Preferably, during
30 step S4 it is exerted onto the layers a pressure of at least 350 kg/sqm.

Then in a step S4 pressed floor element 1 is then carried into a stocking station 44 wherein for a predetermined stocking time in order to allow the resin R to continue curing

before being, packaged, transported and/or used in a floor covering. Preferably the stocking time is such to allow the resin R to be at least 70% cured, preferably 85% cured, more preferably fully cured. For example, said stocking time is at least 0.5 h, preferably more than 1 h, for example 2 h.

5 According to a preferred embodiment of the invention, the method comprises a step of compressing the decorative layer 2. Said step of compressing preferably substantially coincide with the curing of the resin R and, in the example showed in the drawing, with the stocking step. In fact, the decorative layer 2 is preferably compressed by the shrinkage of the resin during curing in order to be reinforced against impacts. It is to be noted that upon this compression
10 the floor element 1, after curing, shows a planarity deviation PD higher than the planarity deviation PD of the decorative layer 2 before application of the resin R.

Figure 13 shows a top plane view of a kit for installing the floor elements 1 for forming the floor covering 25 wherein the kit comprises a first and a second first tool 50,51 and a second tool 52. The kit further comprises an automatic and/or electric hammer 60 having a body
15 adapted to be handled by at least an operator said body housing a motor or operating element adapted to activate an operative end 61, said end being adapted to cooperate with an edge of the decorative layer 2 and/or with a second beating surface 55 of between the first 50,51 and second tool 52. The hammer 60 is only schematically illustrated in the drawings.

Figure 14 on a larger scale shows a cross section of the first tool 50 along the plane
20 XIV-XIV of Figure 13. The First tool 50 comprises a body 53 having first beating surface 54 adapted to contact a surface of the decorative layer 2, and a second beating surface 55 adapted to be hammered.

In Figure 14 is shown a first tool 50 according to a preferred embodiment wherein the first beating surface 54 is adapted to contact the surface of the 13 edge of the decorative layer
25 2 of the floor element 2. In the example, the first beating surface 54 is adapted to be placed vertical in use, and, preferably, said first beating surface has a vertical dimension TT (in use) substantially equal or lower than the thickness of the decorative layer, for example said vertical dimension TT is lower than 15 mm, preferably lower than 10 mm, for example about 8 mm. In this way the first beating surface 54 can transfer to the decorative layer 2 horizontal forces
30 exerted to move horizontally the floor element 1 along the horizontal direction Z toward the adjacent floor element 1 and effecting the coupling via said translational horizontal movement.

Advantageously the first beating surface 54 comprises a soft coating for dampening the hammering force. For example, said soft coating may be made of rubber or a textile like felt.

The second beating surface 55 is parallel to the first beating surface 54. In the embodiment of Figure 14, the second beating surface 55 is provided on the same body 53
5 portion of the first tool 50 and is opposite to the first beating surface 54. Within the scope of the present application “opposite on the same body portion” means that exist one straight line that is orthogonal to both the first beating surface 54 and the correspondent second beating surface 55.

It is to be noted that in the example shown in figures 13 and 14 the first tool 50
10 comprises a couple of orthogonal first surfaces 54 and of correspondent orthogonal second surfaces 55.

The first tool 50 further comprises a handle 56. In a preferred embodiment, the first tool 50 is made of at least a polymeric material, preferably a thermoplastic material, for example polyethylene (PVC), polypropylene (PP), PVC, PET, ABS, PA.

Figure 15 on a larger scale shows a cross section of an alternative embodiment the first
15 tool 51 along the plane XV-XV of Figure 13. In Figure 15 is shown a first tool 51 according to an alternative embodiment wherein the first beating surface 54 is substantially equal to that of the embodiment shown in Figure 14. In this alternative embodiment the second beating surface 55 is provided on a different body portion of the correspondent first beating surface. Within
20 the scope of the present application “not being opposite on different body portion” means that there is not one straight line that is orthogonal to both the first beating surface and the correspondent second beating surface. In fact, in this embodiment, the body 53 of the first tool 51 is conformed substantially in an S-shape and it is provided with the first beating surface 54 on a extremal portion of said body 53 and with the second beating surface 56 on the other
25 extremal portion of the body 53. This solution is particularly effective when it is needed to hammer a floor element in a position of the room where the operation is difficult for the limited space, for example close to a wall.

Figure 16 on a larger scale shows a cross section of the second tool 52 along the plane
XVI-XVI of figure 13. The second tool 52 comprises a handle portion 57 and a plane portion
30 58. The plane portion 58 is provided with on one edge with a coupling element 59 adapted to be coupled with one correspondent coupling element 11,12 of the board 3. This second tool 52 is particularly useful to couple the transversal edges 28 of two floor elements 1 on a same row

that is parallel to the longitudinal edges 10 of the floor elements 1. In this case the second tool 52 is coupled to the longitudinal edges 10, via its coupling element 59, of both the floor elements 1 so that during the translational horizontal movement along the direction Z to couple the transversal edges 28 it guides said translational movement of the floor elements 1.

5 Preferably the plane portion 58 of the second tool 52 comprises coupling elements 59 on each of its opposite edges. For example, a male coupling element along a first edge and a female coupling element along a second coupling edge.

The present invention is in no way limited to the hereinabove described embodiments, but such floor elements may be realized according to different variants without leaving the scope of the present
10 invention.

Further, as is clear from the content of the description, the present invention relates to one or more of the items as listed below:

1.- A floor element for forming a floor covering, wherein this floor element comprises a decorative layer made of a ceramic material and a board arranged below this decorative layer, wherein the floor
15 element comprises a layer having a resin material disposed below the decorative layer, and wherein said resin compresses the decorative layer.

2.- The floor element according to item 1, wherein the floor element comprises a third layer placed below the second layer.
20

3.- A use of a resin material for bonding together a decorative layer made of a ceramic material and a board to form a floor element, wherein the resin material comprises a viscosity at 20°C below 1000 mPas.

25 4.- The use according to item 3, wherein the resin is an epoxy resin.

5.- A method for manufacturing a floor element comprising the steps of: providing a decorative layer made of a ceramic material; providing a board; providing a resin material for bonding the decorative layer and the board together; pressing the layers together for forming the floor element such that the
30 resin material permeates the ceramic layer.

6.- The method according to item 5, wherein the step of providing the decorative layer comprises a step of brushing and/or roughing the lower surface of the decorative layer.

7.- The method according to item 5 or 6, wherein the method comprises a step of annealing the board.

8.- The method according to any one of items 5 to 7, wherein the method comprises a step of treating the upper surface of the board.

5

9.- The method according to item 8, wherein said step of treating the upper surface of the board comprises the step of roughing the upper surface of the board.

10.- The method according to any one of items 5 to 9, wherein the step of providing the resin comprises the step of applying a non-cured resin on at least a surface of the decorative layer or of the board.

10

11.- The method according to any one of items 5 to 10, wherein during the pressing step it is exerted onto the layers a pressure of at least 350 kg/sqm.

15

12.- The method according to any one of items 5 to 11, wherein during the pressing step, the pressure is kept for a pressing time of more than 1 second.

13.- A method for manufacturing a floor element comprising the steps of: providing a decorative layer made of a ceramic material; providing a board; providing a resin material for bonding the decorative layer and the board together; curing the resin; and promoting the shrinkage of the resin.

20

14.- A tool suitable for installing a floor covering having floor elements, wherein the floor elements comprise a decorative layer and a board disposed below the decorative layer and wherein the board having edges provided with coupling elements adapted to cooperate with coupling elements of an adjacent similar floor element in said floor covering, wherein the first tool comprises a body having first beating surface adapted to contact a surface of the decorative layer, and at least a second beating surface adapted to be hammered.

25

15.- The tool according to item 14, wherein the first beating surface is adapted to contact the surface of an edge of the decorative layer.

30

16.- The tool according to item 14 or 15, wherein the first beating surface has a vertical dimension equal or lower than the thickness of the decorative layer.

17.- The tool according to any one of items 14 to 16, wherein the first beating surface comprises a soft coating.

18.- The tool according to any one of items 14 to 17, wherein the second beating surface is provided on the same body portion of the first tool and is opposite to the first beating surface.

19.- The tool according to any one of items 14 to 17, wherein the second beating surface is provided on a different body portion of the correspondent first beating surface.

20.- A tool suitable for installing a floor covering, wherein the floor covering comprises a board having edges provided with coupling elements adapted to cooperate with coupling elements of an adjacent similar floor element in said floor covering, wherein the second tool comprises an handle portion and a plane portion provided with at least one edge and wherein said edge is provided with a coupling element to be coupled with at least one coupling element of the board.

While several possible embodiments are disclosed above, embodiments of the present invention are not so limited. These exemplary embodiments are not intended to be exhaustive or to unnecessarily limit the scope of the invention, but instead were chosen and described in order to explain the principles of the present invention so that others skilled in the art may practice the invention. Indeed, various modifications of the invention in addition to those described herein will become apparent to those skilled in the art from the foregoing description.

Claims

- 5 1.- A floor element for forming a floor covering, wherein this floor element comprises a decorative layer made of a ceramic material and a board arranged below this decorative layer, wherein the floor element comprises a layer having a resin material disposed below the decorative layer, and wherein said resin compresses the decorative layer.
- 10 2.- The floor element according to claim 1, wherein the floor element comprises a third layer placed below the second layer.
- 3.- A use of a resin material for bonding together a decorative layer made of a ceramic material and a board to form a floor element, wherein the resin material comprises a
15 viscosity at 20°C below 1000 mPas.
- 4.- The use according to claim 3, wherein the resin is an epoxy resin.
- 5.- A method for manufacturing a floor element comprising the steps of: providing a
20 decorative layer made of a ceramic material; providing a board; providing a resin material for bonding the decorative layer and the board together; pressing the layers together for forming the floor element such that the resin material permeates the ceramic layer.
- 25 6.- The method according to claim 5, wherein the step of providing the decorative layer comprises a step of brushing and/or roughing the lower surface of the decorative layer.
- 7.- The method according to claim 5 or 6, wherein the method comprises a step of
annealing the board.
- 30 8.- The method according to any one of claims 5 to 7, wherein the method comprises a step of treating the upper surface of the board.

- 9.- The method according to claim 8, wherein said step of treating the upper surface of the board comprises the step of roughing the upper surface of the board.
- 10.- The method according to any one of claims 5 to 9, wherein the step of providing the resin comprises the step of applying a non-cured resin on at least a surface of the decorative layer or of the board.
- 11.- The method according to any one of claims 5 to 10, wherein during the pressing step it is exerted onto the layers a pressure of at least 350 kg/sqm.
- 12.- The method according to any one of claims 5 to 11, wherein during the pressing step, the pressure is kept for a pressing time of more than 1 second.
- 13.- A method for manufacturing a floor element comprising the steps of: providing a decorative layer made of a ceramic material; providing a board; providing a resin material for bonding the decorative layer and the board together; curing the resin; and promoting the shrinkage of the resin.
- 14.- A tool suitable for installing a floor covering having floor elements, wherein the floor elements comprise a decorative layer and a board disposed below the decorative layer and wherein the board having edges provided with coupling elements adapted to cooperate with coupling elements of an adjacent similar floor element in said floor covering, wherein the first tool comprises a body having first beating surface adapted to contact a surface of the decorative layer, and at least a second beating surface adapted to be hammered.
- 15.- The tool according to claim 14, wherein the first beating surface is adapted to contact the surface of an edge of the decorative layer.
- 16.- The tool according to claim 14 or 15, wherein the first beating surface has a vertical dimension equal or lower than the thickness of the decorative layer.

17.- The tool according to any one of claims 14 to 16, wherein the first beating surface comprises a soft coating.

5 18.- The tool according to any one of claims 14 to 17, wherein the second beating surface is provided on the same body portion of the first tool and is opposite to the first beating surface.

10 19.- The tool according to any one of claims 14 to 17, wherein the second beating surface is provided on a different body portion of the correspondent first beating surface.

15 20.- A tool suitable for installing a floor covering, wherein the floor covering comprises a board having edges provided with coupling elements adapted to cooperate with coupling elements of an adjacent similar floor element in said floor covering, wherein the second tool comprises an handle portion and a plane portion provided with at least one edge and wherein said edge is provided with a coupling element to be coupled with at least one coupling element of the board.

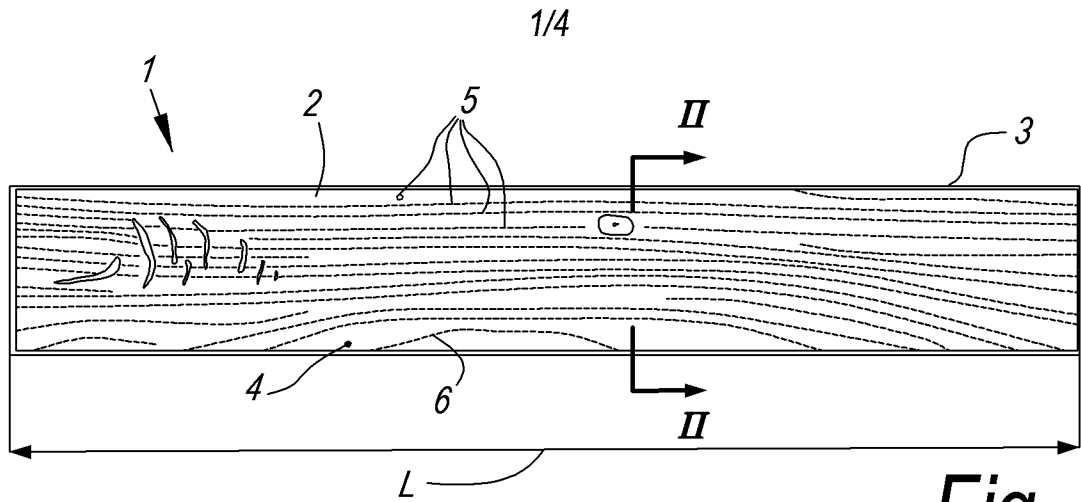

Fig. 1

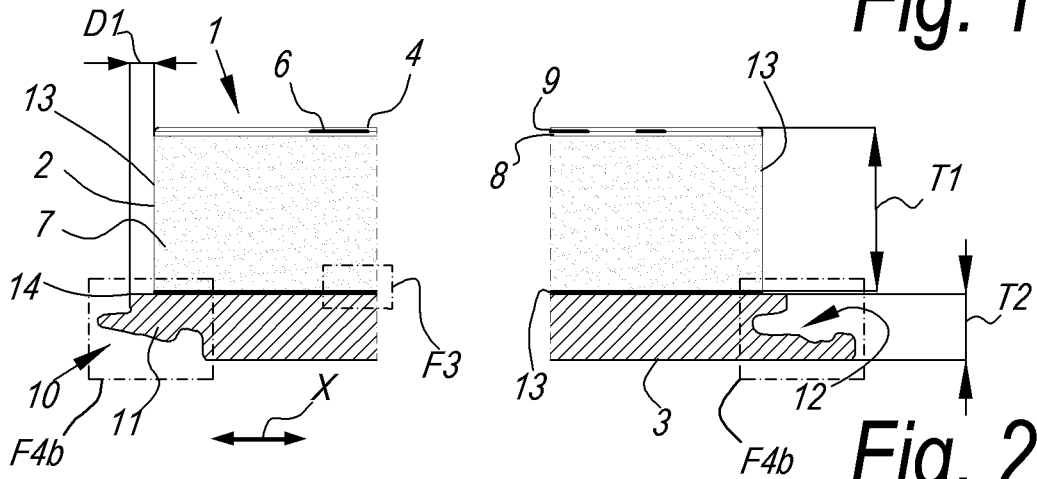

Fig. 2

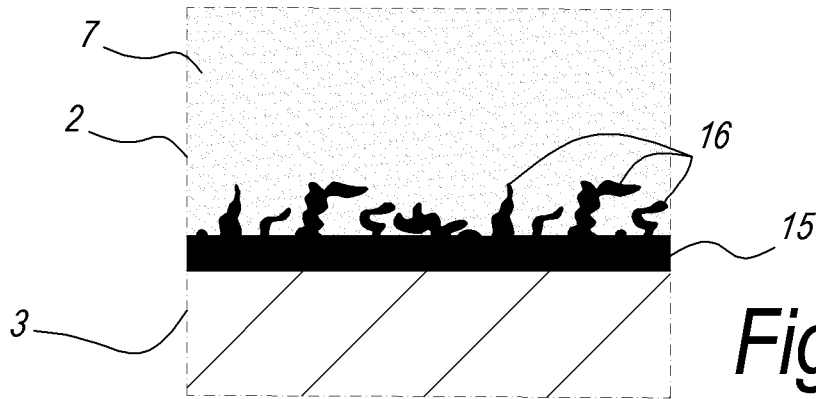

Fig. 3

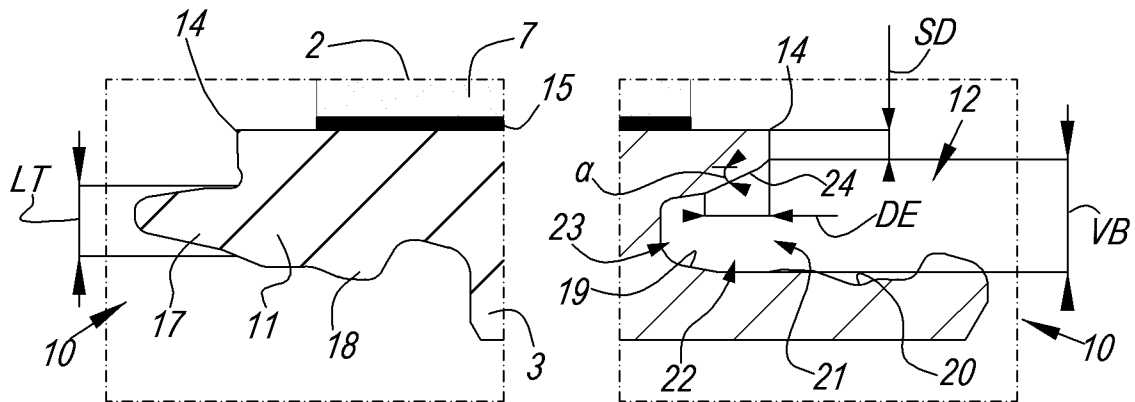
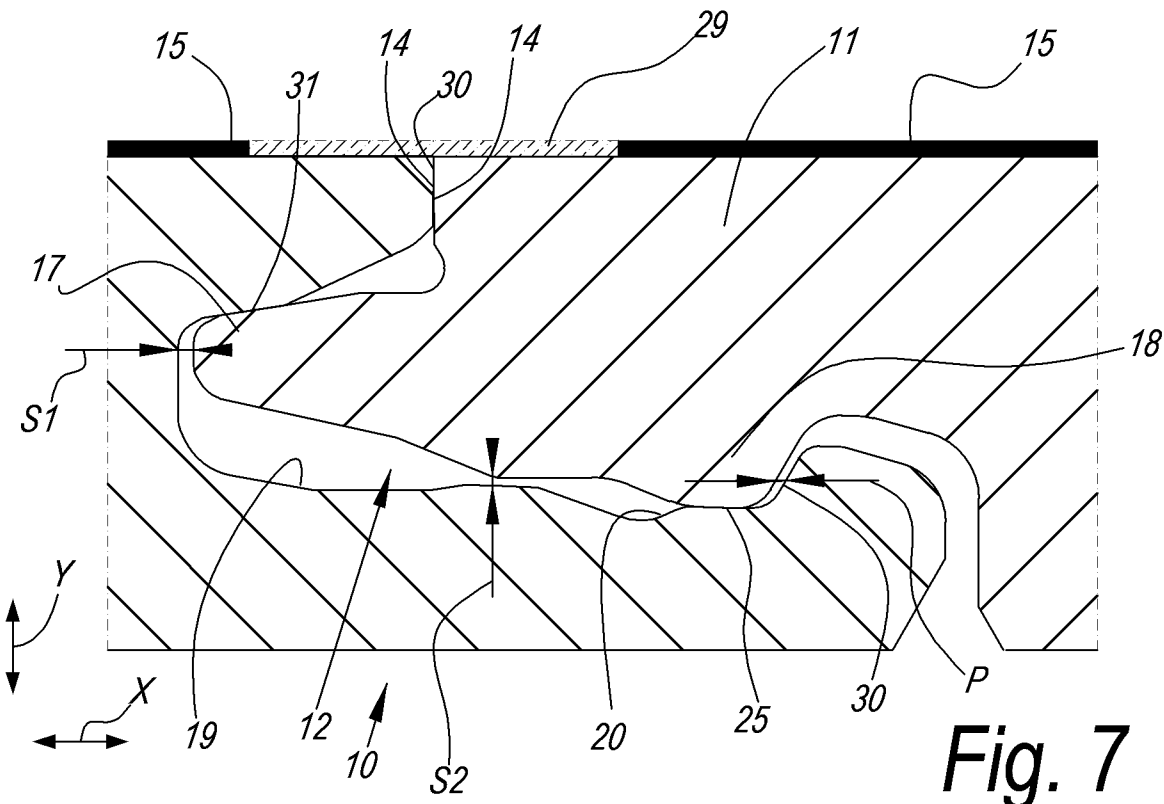
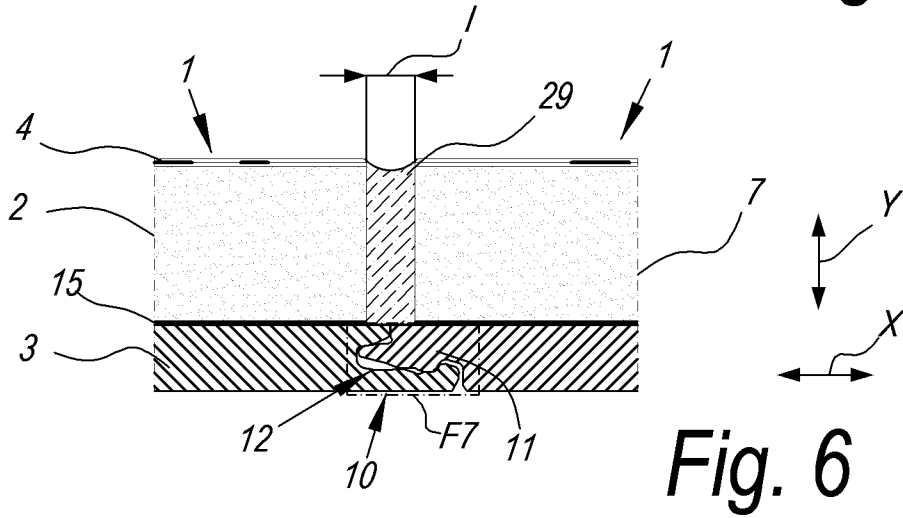
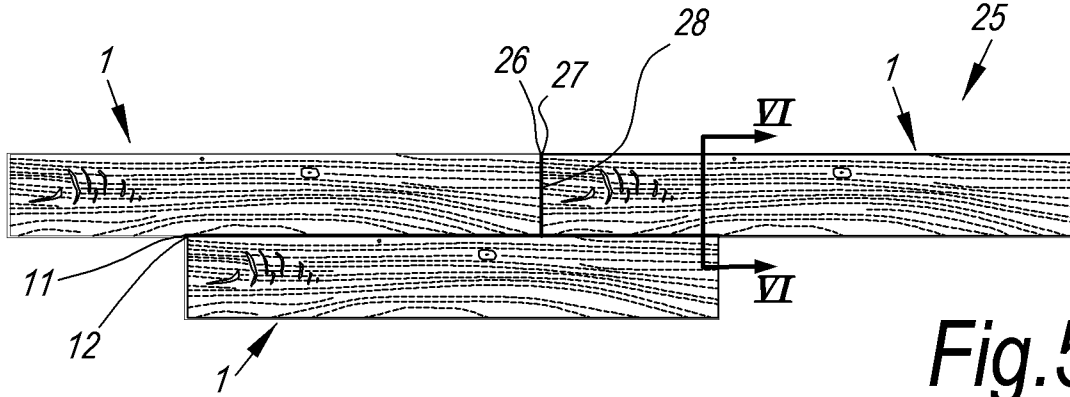

Fig. 4a

Fig. 4b



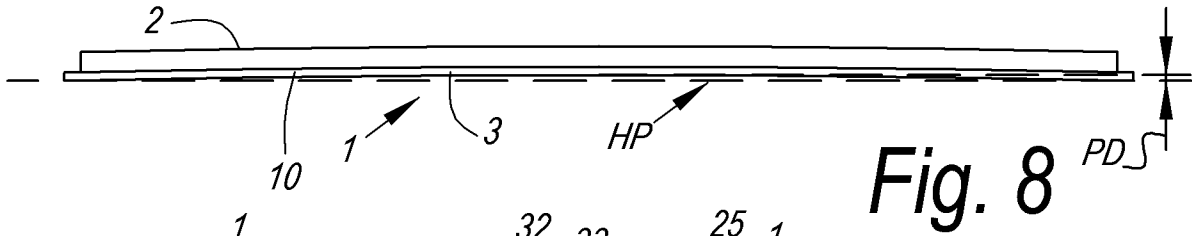

Fig. 8

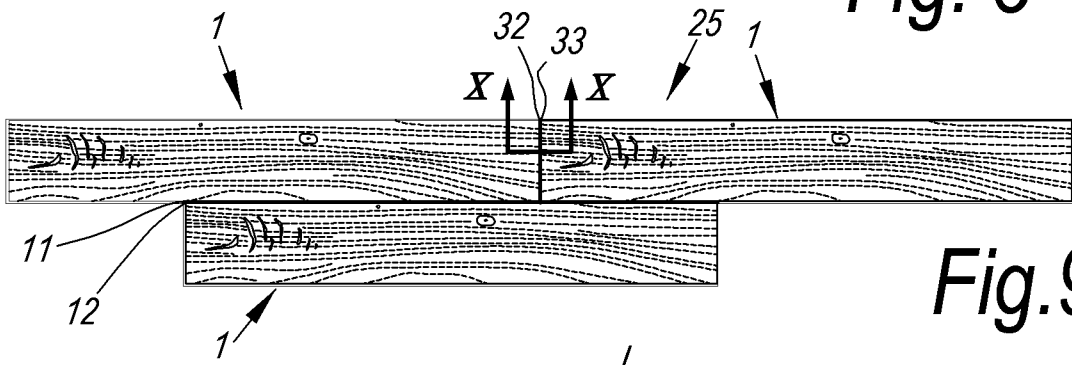

Fig. 9

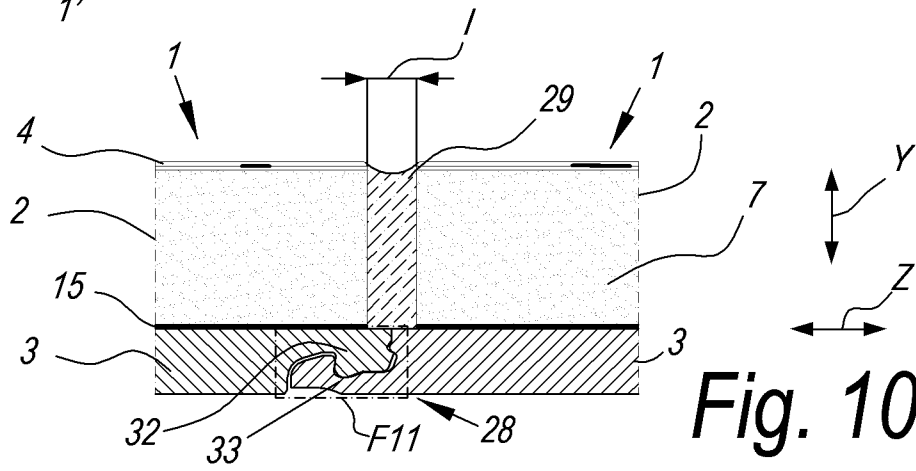

Fig. 10

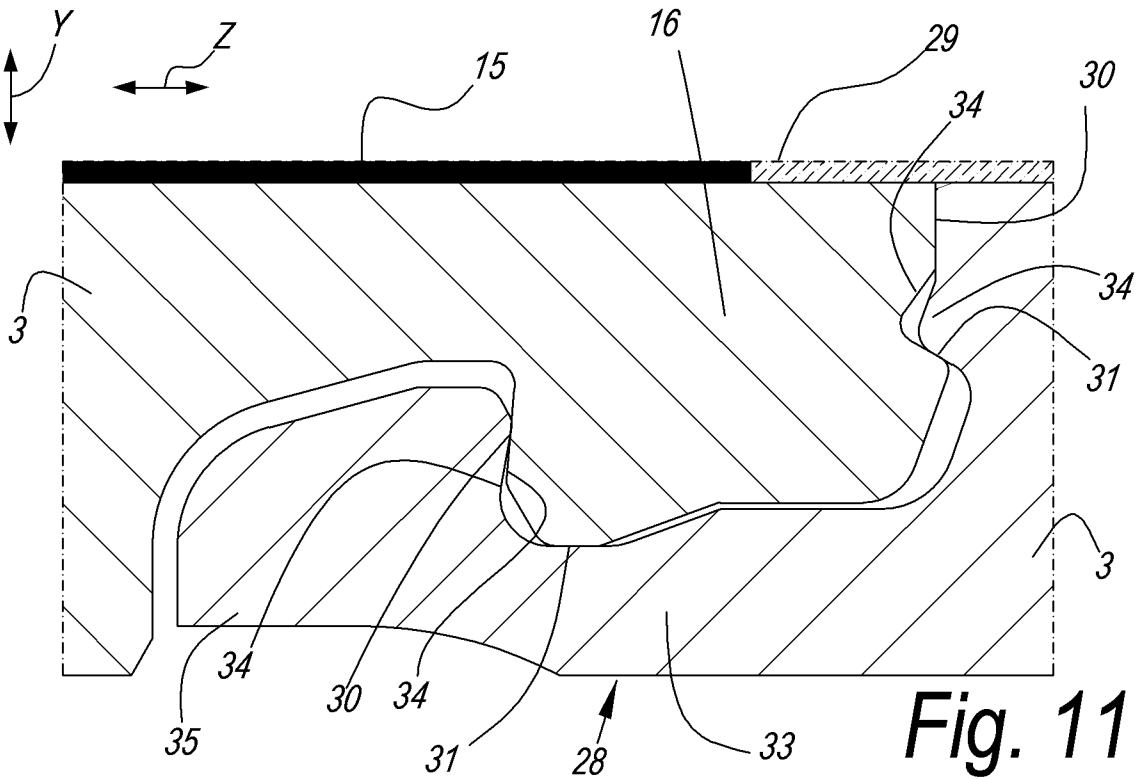

Fig. 11

