



Jan. 29, 1935.

B. L. KEENEY

1,989,367

DENTURE ARTICULATOR

Filed May 29, 1933

3 Sheets-Sheet 2

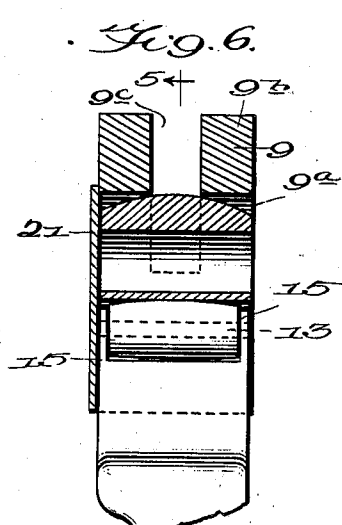
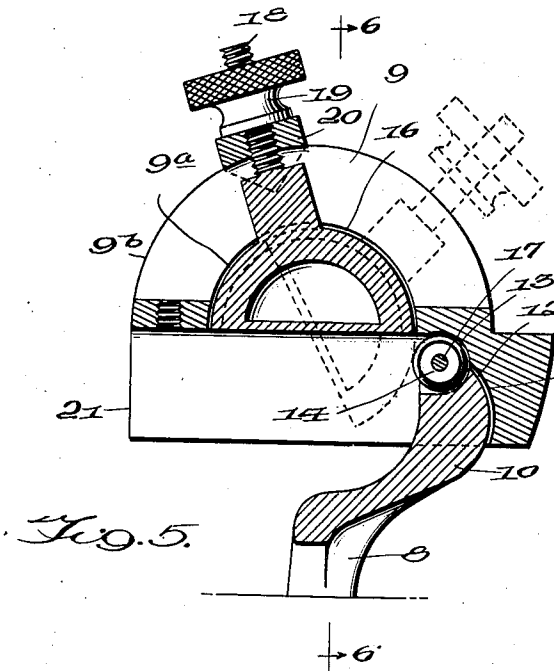
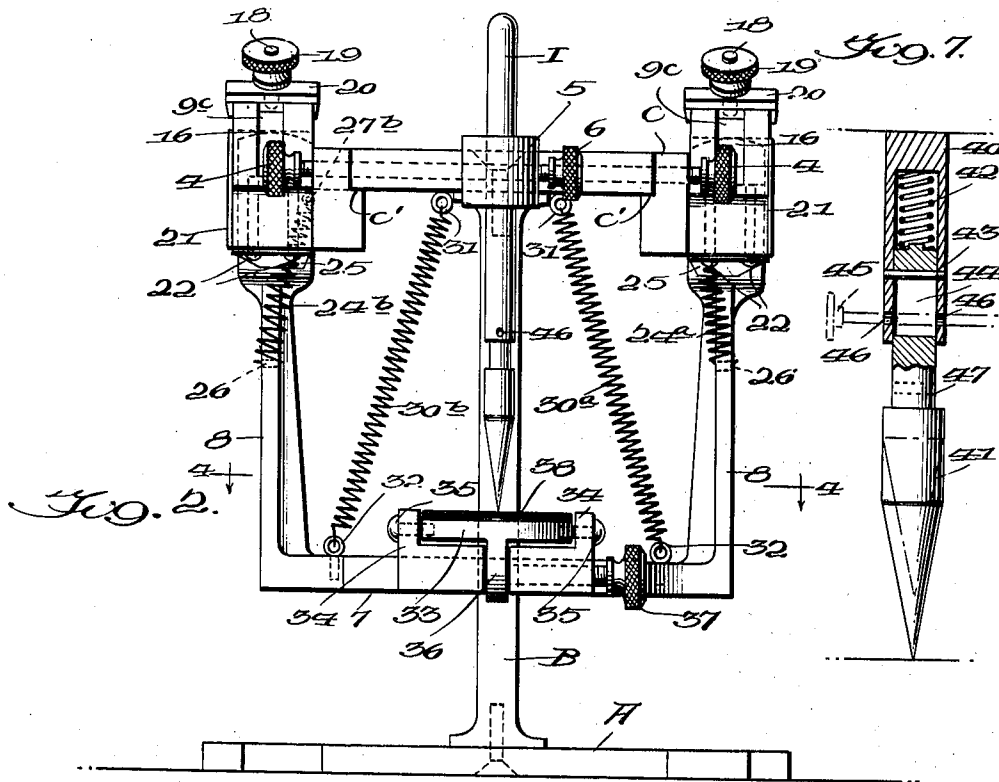

INVENTOR  
5 Bert L. Keeney,  
BY Richard E. Babcock  
ATTORNEY



# UNITED STATES PATENT OFFICE

1,989,367

## DENTURE ARTICULATOR

Bert. L. Keeney, Princeton, Ky.

Application May 29, 1933, Serial No. 673,567

7 Claims. (Cl. 32—32)

This invention relates to denture articulators for use in the construction of artificial dentures.

The primary objects of my invention are to provide an articulator in which the lower arm, support or jaw moves, as in nature, rather than the upper arm, jaw or support; to provide in such an articulator a joint composed of arcs to enable a dentist using the machine to more accurately set the same to follow the arc paths as recorded by movements of the patient's mandible or lower jaw; to provide an articulator whereby it is possible to grind in a set of artificial teeth in the arc paths of travel or movement of the patient's mandible or lower jaw; to provide an articulator which follows the arcs, which form the Gothic arch tracing of the patient, rather than the chord of the arc; and to provide a construction whereby the upper arm, jaw or support may be released and thrown back out of the way when necessary or desired to promote convenience in the setting up of artificial teeth.

In this application I show and describe only the present preferred embodiment of my invention simply by way of illustration of the practice thereof as by law required. However, I am aware that my invention is capable of other and different embodiments and that the several details thereof may be modified in various ways, all without departing from my said invention, and therefore the drawings and description herein are to be considered as merely illustrative and not as exclusive.

In the accompanying drawings:

Figure 1 represents a side elevation of an articulator embodying my invention;

Figure 2, a front elevation thereof;

Figure 3, a top plan view thereof;

Figure 4, a sectional view on the line 4—4 of Fig. 2 and looking in the direction of the arrows, the springs 30, eyelets 32 and incisal pin I being omitted;

Figure 5, a longitudinal detail sectional view on the line 5—5 of Fig. 6, looking in the direction of the arrows, of one of the two condyle joint assemblies;

Figure 6, a cross sectional view on the line 6—6 of Fig. 5, looking in the direction of the arrows;

Figure 7, a detail sectional view through the telescoped portions of the sections 40 and 41 of the incisal pin I; and

Figure 8, a detail fragmentary sectional view on the line 8—8 of Fig. 4, looking in the direction of the arrows.

Referring now in detail to the drawings, A

designates the base, to which is secured in any usual and convenient manner an upright B which supports rigid therewith a top frame C which has its forward portion bifurcated and in the furcation of which is disposed the upper support or jaw 1, said jaw 1 being hingedly mounted in frame C by means of a hinge or pivot pin 2 passing through the rear portion of said support 1 and being received on either side thereof in the said frame C. Said support or jaw member 1 normally rests on the shoulder C' of the frame C in front of hinge pin 2 and, normally during the grinding operation of the articulator, is locked in such position by means of the locking screws 4 working through the sides of said frame C and engaging the side faces respectively of the support or jaw 1.

The upper jaw 1 and the lower jaw 7 are each provided with an opening G to receive and secure the plaster of a plaster support D for their respective sets of artificial teeth E and F, cross pins H respectively extending transversely through the area of said opening G and being removably received in sockets in the said jaws, whereby on removal of said pins H the plaster cast supports may be removed from the articulator.

The upper support or jaw 1 is provided in the central portion of its forward end portion with a centrally vertically bored boss 5 to adjustably receive the incisal pin I, a clamping or friction screw 6 threaded through the wall of said boss and adapted to engage said incisal pin I serving to secure the latter in any desired position of adjustment.

The lower jaw or support 7 is movably suspended with relation to the upper support 1 for movement with relation thereto corresponding to the arcs of the Gothic arch of a particular patient to which the articulator is adjusted and to that end the forward portion of the jaw 7 carries a table or plate 33 for holding a tracing of the patient's Gothic arch arcs in predetermined position thereon and in proper relation to the incisal pin, so that the proper movement of the jaw 7 as required by the Gothic arch of a particular patient will cause said table to move in a path with respect to said incisal pin corresponding to the arcs of the Gothic arch of said patient, and the rear portion of the jaw 7 is provided with arms 8 having condyle heads 10 formed with arcuate rear faces 12 adapted to slidably engage correspondingly formed faces 11 of condyle sockets formed in the upper condyle member 9, and carrying in their extreme upper

end portions respectively between arms 15 flattened elliptical-form anti-friction rollers 14 partially received in smaller upper socket arcuate portions 13 of said upper condyle members 9 and normally bearing against the face thereof, said anti-friction rollers 14 respectively being mounted between the arms 15 of the respective condyle heads 10 by means of a pivot pin 17 extending through said arms 15 and the axis of the roller.

In each upper condyle section 9 is disposed an arcuate guide member 16 guided in said upper condyle member 9 by the arcuate inner face 9<sup>a</sup> thereof representing the glenoid fossa and having a screw-threaded stem 18 extending upward through a slot 9<sup>c</sup>, said stem receiving a clamping block 20 adapted to be clamped against the upper arcuate faces 9<sup>b</sup> of said upper condyle member 9 by a nut 19 turning on the stem 18, whereby said control or guide arc 16 may be moved to any desired position of adjustment as may be required by the peculiarities of the Gothic arch of a particular patient, and there locked in such adjusted position as indicated in dotted lines in Fig. 5. The radially outer or operative face of each of these control arcs or arc path controls 16 is rounded or convex in cross section, in opposition to the elliptical face of the roller 14, as well illustrated in Fig. 6 to promote freedom of twisting and rocking movements of the roller 14 between the arcuate or opposed convex face of the arc path control 10 and the upper part of the condyle socket, and with relation to the convex or arcuate face of the arc path control 10 when the roller 14 is displaced from the upper portion of the condyle socket.

Limit or stop plates 21 are provided on the outer sides of the upper condyle members 9 to prevent lateral movement thereof of the condyle heads 10, the distance between the opposed faces of the plates 21 being slightly in excess of the distance between the outer edges of the condyle heads 10, so that as assembled there is a little play between the outer edge or face of each condyle head 10 and the opposed inner face of the corresponding plate 21, whereby the condyle heads 10 may move and twist as required with respect to their compound sockets 11 and 13, and with respect to the arc path controls 16 without interference by the plates 21.

Upper condyle joint members 9 may be formed integral with upper frame C or may be formed separately therefrom and secured thereto by vertical screws 22 at their forward end portions and horizontal screws 23 extending forwardly through the frame C from the rear portion thereof and engaging in the rear portions of the respective members 9 as illustrated, or by any other convenient means suitable to the purpose.

The condyle heads 10 are to be resiliently suspended and urged toward their respective sockets in the respective members 9 by spring means associated and interrelated in such manner as to approach the disposition and functioning of the muscles of mastication as closely as possible.

In the embodiment illustrated said spring means consists of a pair of front springs 24<sup>a</sup> and 24<sup>b</sup>, a pair of rear springs 27<sup>a</sup> and 27<sup>b</sup> and a pair of long intermediate springs 30<sup>a</sup> and 30<sup>b</sup>, these springs being all under tension and so disposed that the individual springs of each pair exert a lateral pull in opposition to each other and so that the individual springs of the front pair exert a forward pull in opposition to the rearward pull of the corresponding individual springs of the rear pair of springs.

The pair of springs 24<sup>a</sup> and 24<sup>b</sup> extend forwardly and upwardly and converge upwardly and inwardly and have their respective lower end portions connected to the upper portions of the respective arms 8 as by being hooked into perforations 26 in said arms 8 and have their upper ends hooked through or into perforations in clips 25 respectively secured against the respective lower faces of the respective side portions of frame C at points appreciably in advance of the arms 8 as illustrated in Fig. 1. Said springs 24<sup>a</sup> and 24<sup>b</sup> are under appreciable tension in operation and exert an inward upward and forward pull on the legs 9, the inward pull of the spring 24<sup>a</sup> being opposed by the inward pull of the spring 24<sup>b</sup>.

The springs 27<sup>a</sup> and 27<sup>b</sup> extend rearwardly and upwardly and converge upwardly and inwardly and are connected to the upper portions of the respective arms 8 in any suitable manner, as by being hooked through perforations 29 in the respective legs and preferably in the same horizontal plane as the perforations 26 and have their upper and rear ends connected to the frame C in any suitable manner, as by being hooked through perforations in clips 28 secured to the frame C. The inward pull of the spring 27<sup>a</sup> is opposed to the inward pull of the spring 27<sup>b</sup>, the forward pull of the spring 24<sup>a</sup> being opposed by the rearward pull of the spring 27<sup>a</sup> and the upward pull of spring 24<sup>a</sup> being supplemented by the upward pull of the spring 27<sup>a</sup> and tending to hold the condyle head 10 against the corresponding socket. What has been said as to the functioning of springs 24<sup>a</sup> and 27<sup>a</sup> is true also of the springs 24<sup>b</sup> and 27<sup>b</sup> in their relation to each other and their relation to springs 24<sup>a</sup> and 27<sup>a</sup>.

The springs 30<sup>a</sup> and 30<sup>b</sup> are longer and stronger than any of the springs above mentioned and carry the main weight of the lower support or jaw 7 with its arms 8, plate or table 33 and associated parts and its supported plaster cast D and lower set of teeth F. Said springs 30<sup>a</sup> and 30<sup>b</sup> extend from the frame C to the lower jaw or support 7 and converge inwardly and upwardly, having their lower ends connected to the support or jaw 7 by any suitable means, as for instance by being hooked into the respective eyes 32 secured to said jaw 7 and may have their upper ends similarly respectively hooked into the respective similar eyelets 31 secured to or integral with the frame C, and said springs 30<sup>a</sup> and 30<sup>b</sup> will preferably extend slightly rearward from their point of attachment to the support or plate 7 to exert an upward and rearward pull on the support or jaw 7 in simulation of the corresponding human muscles of mastication.

The forward end of the lower support or jaw 7 will be extended forward and provided with a pair of arms 34 for pivotally supporting between them in centered position with relation to the point of the incisal pin I the usual table or plate 33, said plate 33 being pivotally held in position between said arms 34 by pivot pins 35 having a common center and passing through the respective arms 34. Said plate 33 is provided with a rib or fin 36 disposed in a slot in the end of the support or jaw 7 to be engaged by a clamping screw 37 to lock the plate 33 in any position of angular adjustment about the common axis of the pins 35 according as may be required by the peculiar jaw formation of a particular patient. A generally U-shaped form or broken circle form resilient spring 38 secured at its end portions by rivets 39 to the upper face of the table or plate

33 and resiliently bearing with its free portion against the opposed face portion of said plate 33 serves as a convenient means for clamping in correct position against the face of the plate or table 33 and with relation to the point of the incisal pin I, the usual tracing or guide J bearing the Gothic arch arcs of a particular patient and holding the same in the definite position as required by the peculiarities of said patient.

The incisal pin I comprises an upper portion 40 and a lower portion 41, the lower portion of upper portion 40 being bored or hollowed out to telescopically receive the reduced upper part of lower portion 41, a spring 42 being disposed in said bore between the upper end of said bore and the opposed upper end of portion 41 and normally operating to force portion 41 downward out of portion 40. A pin 43 passing through portion 40 and being disposed in a long vertical slot 44 in portion 41 serves to permanently secure these portions 40 and 41 together while permitting compensatory vertical movement of the portion 41, as may be required by the movements of the lower support or jaw 7, with relation to the upper portion 40, which will normally be locked against movement by the screw 6.

The lower portion 41 is provided at a point below the slot 44 with a perforation 47 parallel to said slot 44 and the portion 40 is provided with a pair of perforations 46 registering transversely with each other and with which the perforation 47 is adapted to be brought into registration to receive a pin 45 when it is desired to hold the portion 41 up out of operative position.

In case a particular patient has a perfect Gothic arc, according to Gysi's theory, as revealed by his tracing J held clamped to the table 33, the control or guide arcs 16 or arc path controls 16 will be set at the same points about their respective axes so as to extend to the same degree below the axes of the respective rollers 14 when the latter are at rest in their sockets, whereby said rollers 14 may move to the same extent downward and forward about the surfaces of the respective arc path controls 16. The exact points under such conditions at which said arc path controls 16 would be set would be determined by the extent of jaw movement of the particular patient, the actual manipulation of the lower jaw or support 7 being such that with the rollers 17 held in contact with the arc path controls 16 the movement of the plate 33 with relation to the point of incisal pin I would be in the paths of the arcs of the Gothic arch supported on the table 33.

In case the right condyle head or joint is abnormally forwardly located, the right arc path control 16 would be moved to a corresponding degree with relation to the left arc path control 16 and thereafter both arc path controls 16 would be moved to the degree necessary to accord with the degree of movement of the said patient's lower jaw or mandible. In case of the abnormal rearward location of the patient's right condyle joint or head the left arc path control 16 would be moved to the necessary degree with relation to the right arc path control 16 to compensate for the abnormality and thereafter both arc path controls 16 would be moved as required to permit movement according with the patient's record.

Thus, the adjustment of the two arc path controls 16 with respect to each other and to the respective condyle heads serves to give a quick and wide range of control and adjustment whereby a set of artificial teeth may be ground in in

accordance with the arcs of the Gothic arch of any particular patient.

It is not absolutely essential that the rollers 14 be provided, as the said rollers 14, pins 17, and arms 15 might be dispensed with, the heads 10 being formed with integral tips corresponding in form, however, to the upper half of the respective rollers 14 so as to function in the same way as the rollers 14 except that they are not free to rotate. However, the construction embodying the rollers 14 as illustrated is by far preferred as eliminating friction in the operation of the articulator.

Having thus described my invention, what I claim as new and desire to secure by Letters Patent is:

1. A denture articulator comprising a frame, an upper denture support, and a lower denture support resiliently movably suspended with relation to said frame beneath said upper denture support, in combination with a pair of upper condyle joint members respectively rigidly mounted on said frame, a pair of vertical arms extending upward from said lower denture support and respectively having their upper portions formed into condyle heads respectively received in the upper condyle joint members, each of the latter comprising a vertically slotted body having a radially inner arcuate guide face, a radially outer arcuate clamping face, an arc path control having an arcuate face corresponding to said guide face and having its radially outer face convex in cross section, a screw-threaded stem extending from said control through the slot in said member, a clamping plate slipped over said stem and adapted to bear against the radially outer arcuate clamping face of said member, each said body having a rear downwardly depending portion having its front face formed with a condyle socket comprising a lower generally vertically disposed arcuate face and an upper generally horizontally disposed arcuate face intersecting the lower arcuate face and being disposed closely adjacent to said arc path control and intersected by the line of the chord of the arc of the guide face, and each said condyle head being formed with an arcuate rear face corresponding in form to, and to have sliding contact with, the lower arcuate face of its corresponding socket, and carrying in its extreme tip portion a roller mounted for rotation and substantially corresponding in diameter to, and adapted to fit in, the upper arcuate face, said roller being elliptical in longitudinal section whereby it may rock endwise of its axis with relation to the opposed convex face of its arc path control.

2. A denture articulator comprising a frame, an upper denture support, and a lower denture support resiliently movably suspended with relation to said frame beneath said upper denture support, in combination with a pair of upper condyle joint members respectively rigidly mounted on said frame, a pair of arms extending upward from said lower denture support and respectively having portions formed into condyle heads respectively received in the upper condyle joint members, each of the latter comprising a body having a radially inner arcuate guide face, an arc path control having an arcuate face corresponding to said guide face and having its radially outer face convex in cross section, and means for securing said control in any desired adjusted position in said body, each said body having a rear downwardly depending portion having its front face formed with a condyle socket closely adjacent to said arc path control.

5 trol, and each said condyle head corresponding in form to its respective socket, and carrying in its extreme tip portion a roller mounted for rotation, said roller being elliptical in longitudinal section whereby it may rock endwise of its axis with relation to the opposed convex face of its arc path control.

10 3. A denture articulator comprising a frame, an upper denture support, and a lower denture support resiliently movably suspended with relation to said frame beneath said upper denture support, in combination with a pair of upper condyle joint members respectively rigidly mounted on said frame, a pair of arms extending upward from said lower denture support and respectively having portions formed into condyle heads respectively received in the upper condyle joint members, each of the latter comprising a body having a radially inner arcuate guide face, and an arc path control having an arcuate face corresponding to said guide face, each said body having a rear downwardly depending portion having its front face formed with a condyle socket closely adjacent to said arc path control, and each said condyle head corresponding in form to its respective socket, and having its extreme tip portion of convex contour transversely of the articulator with relation to the opposed face of its arc path control.

30 4. A denture articulator comprising a frame, an upper denture support, and a lower denture support resiliently movably suspended with relation to said frame beneath said upper denture support, in combination with a pair of upper condyle joint members respectively rigidly mounted on said frame, a pair of arms extending upward from said lower denture support and respectively having portions formed into condyle heads respectively received in the upper condyle joint members, each of the latter comprising a body having a radially inner arcuate guide face and an arc path control having an arcuate face corresponding to said guide face, each said body having a rear downwardly depending portion having its front face formed with a condyle socket closely adjacent to said arc path control, and each said condyle head corresponding in form to its respective socket, and having its extreme tip portion in movable contact with the opposed face of its arc path control.

5 5. An articulator comprising a pair of condyle joints, each said joint comprising an upper member and a condyle head, each said upper members comprising a body having a radially inner arcuate guide face and being formed with a socket depending below said guide face for its respective condyle head, in combination with an arc path control having an arcuate face corresponding to said guide face and in sliding contact therewith, the radially outer face of said control being convex in cross section, and means for adjusting said control so as to extend to any desired degree below said guide face and in front of said socket and the condyle head received in said socket, an elliptical shape roller being mounted for rotation in the extreme tip of each said condyle head and adapted to be moved into any of a great variety of slanting positions with relation to its axis between said socket and said control and while remaining in contact with either or both of the opposing faces of said control and socket.

10 6. An articulator comprising a pair of condyle joints, each said joint comprising an upper member and a condyle head, each said upper member comprising a body having an arcuate guide face and formed with a socket depending below said guide face, in combination with an arc path control having an arcuate face corresponding to said guide face and in sliding contact therewith, the radially outer face of said control being convex in cross section, and means for adjusting said control so as to extend to any desired degree below said guide face and in front of said socket and the condyle head normally received in said socket.

35 7. An articulator comprising a pair of condyle joints, each of said joints comprising an upper member and a condyle head, each said upper member being adapted to movably receive its cooperating condyle head and comprising a body having an arcuate guide face, in combination with an arc path control having an arcuate face convex in cross section and corresponding to said guide face and in sliding contact therewith whereby said condyle heads will be controlled in movement to move in the paths of arcs and thus reproduce all movements of the human mandible.

BERT L. KEENEY.