

(No Model.)

J. B. SMITH.
MAGNETO CALL BELL.

No. 526,982.

Patented Oct. 2, 1894.

Fig. 1.

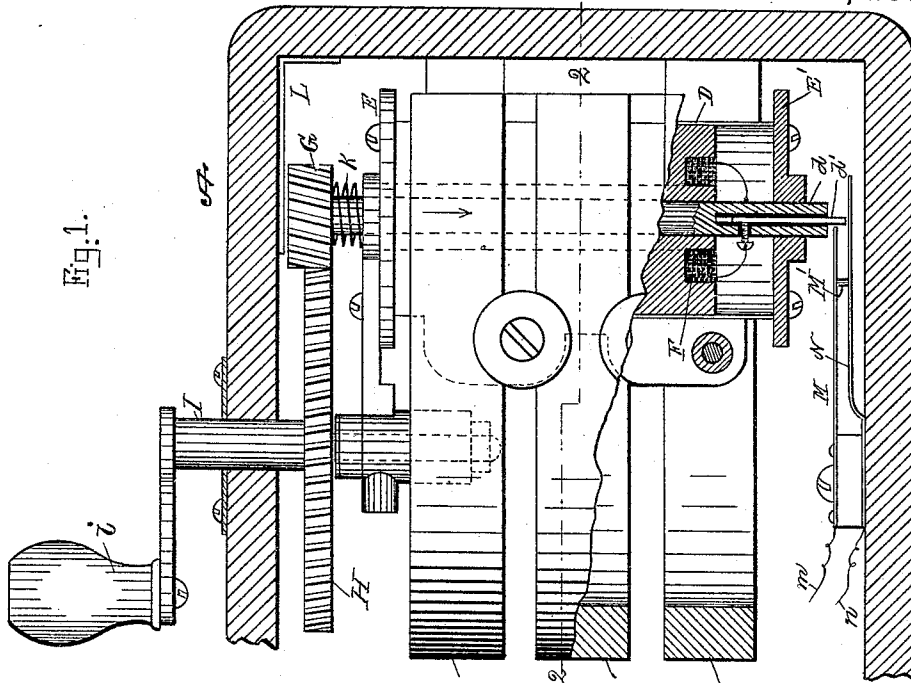

Fig. 2.

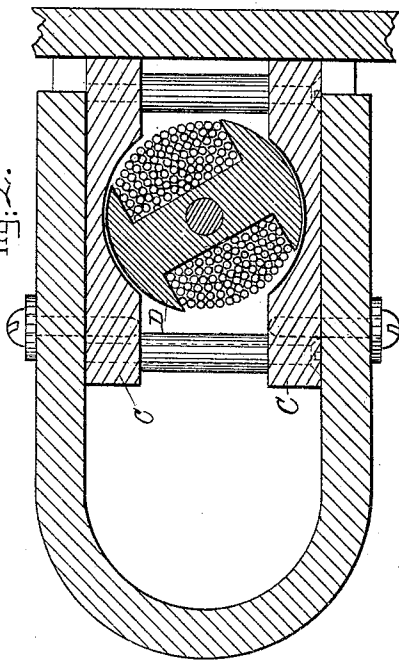

Fig. 3.

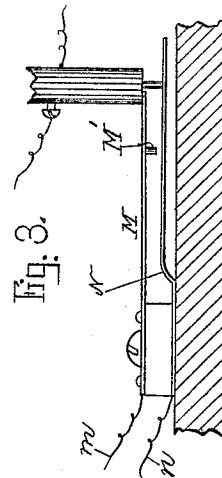
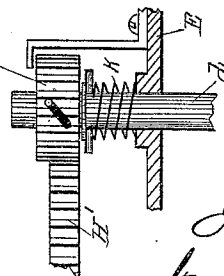

Fig. 4.



Witnesses.

Lauritz N. Moller,
Kittie M. Hanson.

Inventor.

Joseph Brodie Smith
by Wm. Andrew
his atty.

UNITED STATES PATENT OFFICE.

JOSEPH BRODIE SMITH, OF MANCHESTER, NEW HAMPSHIRE.

MAGNETO CALL-BELL.

SPECIFICATION forming part of Letters Patent No. 526,982, dated October 2, 1894.

Application filed April 27, 1894. Serial No. 509,198. (No model.)

To all whom it may concern:

Be it known that I, JOSEPH BRODIE SMITH, a citizen of the United States, and a resident of Manchester, in the county of Hillsborough and State of New Hampshire, have invented new and useful Improvements in Magneto Call-Bells, of which the following, taken in connection with the accompanying drawings, is a specification.

This invention relates to improvements in magneto call bell devices for telephones and it is carried out as follows, reference being had to the accompanying drawings, wherein—

Figure 1, represents a top plan view of the invention in its normal position partly shown in section. Fig. 2, represents a cross section on the line 2—2 shown in Fig. 1. Fig. 3, represents a side elevation of the circuit breaker showing it in position while ringing in a call preparatory to using the telephone; and Fig. 4, represents a modification of the pinion on the armature shaft.

Similar letters refer to similar parts wherever they occur on the different parts of the drawings.

A represents the call box of a telephone as usual in which is located a magneto generator composed of horse shoe magnets B, B, B, having pole pieces C, C, and revolving armature D, secured to a shaft *d* journaled in bearings E, E', as shown.

F, is the wire of the armature winding, one end of which is metallically connected to the shaft *d* and having its other end connected to a spindle *d'* which projects beyond one end of the shaft *d* and is insulated from the latter as fully shown in Fig. 1.

The armature shaft *d* is longitudinally movable in its bearings and has at one end secured to it a pinion G the teeth of which are preferably made inclined or helical relative to the axis of said shaft as shown in Fig. 1 and adapted to mesh in correspondingly inclined or helical teeth on the spur gear H secured to the shaft I which is suitably journaled and provided with a crank *i*, outside of the box A by means of which it may be rotated whenever it is desired to ring in a call.

The armature, its axis and pinion G are normally held in the position shown in Fig. 1 preferably by means of a spring K arranged between the bearing E and pinion G which

causes the outer face of said pinion to be held against a suitable stop plate, bracket or equivalent device L secured preferably to the inside of the box A as shown in Fig. 1.

M and N are spring metal electrodes insulated from each other and secured in a suitable manner to the interior of the call box A as shown in Figs. 1 and 3. During the use of the telephone said spring electrodes are normally held in metallic contact with each other preferably by means of a metal peg or projection M' attached to the spring electrode M as shown but this precise arrangement is not essential as such peg may be made on either or both of said electrodes or they may be so bent or shaped as to normally be held in metallic contact with each other without departing from the essence of my invention.

To the electrodes M, N, are metallically connected the respective wires *m*, *n*, leading to the telephone circuit through the electro magnet of the call bell.

It will be noticed that during the normal position of the electrodes M, N, the latter are cut out from contact with the armature shaft *d* and its insulated projection *d'* which are the terminals of the armature winding F. By turning the crank shaft I the inclined gear H acting on the inclined pinion G causes the latter, the armature and its shaft *d* to be moved against the influence of the spring K in direction of arrow shown in Fig. 1 causing the metal projection *d'* to be brought against the electrode N, by which it is moved out of contact with the projection M' on the electrode M after which the end of the armature axle *d* is brought in metallic contact with the electrode M as fully shown in Fig. 3, thus closing the circuit through the magneto machine and causing the call bell to be sounded in the call box, central station or connecting telephones.

As soon as the operator stops turning the crank shaft I the armature and its shaft are automatically returned by the influence of the spring K to the position shown in Fig. 1 by which the magneto machine is cut out from the electrodes M, N, and the latter brought in metallic contact with each other.

Instead of using inclined gears H, G, as shown in Fig. 1 I may to equal advantage use ordinary gears H' G' as shown in Fig. 4 and

provide the shaft *d* with a pin or projection adapted to enter an inclined slot in the pinion *G'* or a pin or projection may be attached to said pinion and adapted to work in an inclined groove on the shaft *d* by which the same object is obtained namely to cause a longitudinal movement of the armature shaft of the magneto machine in the direction of arrow shown in Fig. 1 when the crank shaft *I* is rotated for the purpose stated.

Having thus fully described the nature, construction, and operation of my invention, I wish to secure by Letters Patent and claim—

1. A magneto call device for telephones consisting of a magneto machine having a rotary and longitudinally movable armature shaft, a crank-shaft, gearing intermediate said armature-shaft and crank-shaft for imparting the longitudinal movement to the armature-shaft during its rotation, said armature-shaft being adapted when rotated to break the circuit and cut in the armature of the magneto generator, and a spring for returning said armature-shaft to its normal position when at rest, substantially as described.

2. A magneto call device for telephones, consisting of a magneto machine having a rotary and longitudinally movable armature shaft, a pinion *G* mounted upon one end of said shaft and having inclined teeth on its periphery, a crank-shaft *I* having a crank handle *i* and spur-gear *H*, inclined teeth on the spur-

gear meshing with the teeth on the pinion, a circuit breaker operated by the longitudinal movement of the armature shaft to break the circuit and cut in the armature of the magneto generator, and a spring for returning the armature shaft to its normal position, substantially as described.

3. A magneto call device for telephones consisting of a magneto machine having a rotary and longitudinally movable armature shaft, a pinion *G* mounted upon one end of said shaft and having inclined teeth on its periphery, a crank-shaft *I* having a handle *i* and spur-gear *H*, inclined teeth upon the spur-gear meshing with the teeth of the pinion, an insulated projection upon the armature-shaft, a pair of electrodes connected to the telephone circuit and normally held in metallic contact with each other, and adapted to be disconnected and brought into the armature circuit of the magneto machine by the rotation of the armature-shaft, a spring for returning said armature-shaft, and a stop-plate *L*, substantially as described.

In testimony whereof I have signed my name to this specification, in the presence of two subscribing witnesses, on this 13th day of April, A. D. 1894.

JOSEPH BRODIE SMITH.

Witnesses:

ALBAN ANDRÉN,
KITTIE M. HANSON.