

(No Model.)

C. MOMBERG.
TOP PLATE FOR STAIR STEPS.

No. 381,407.

Patented Apr. 17, 1888.

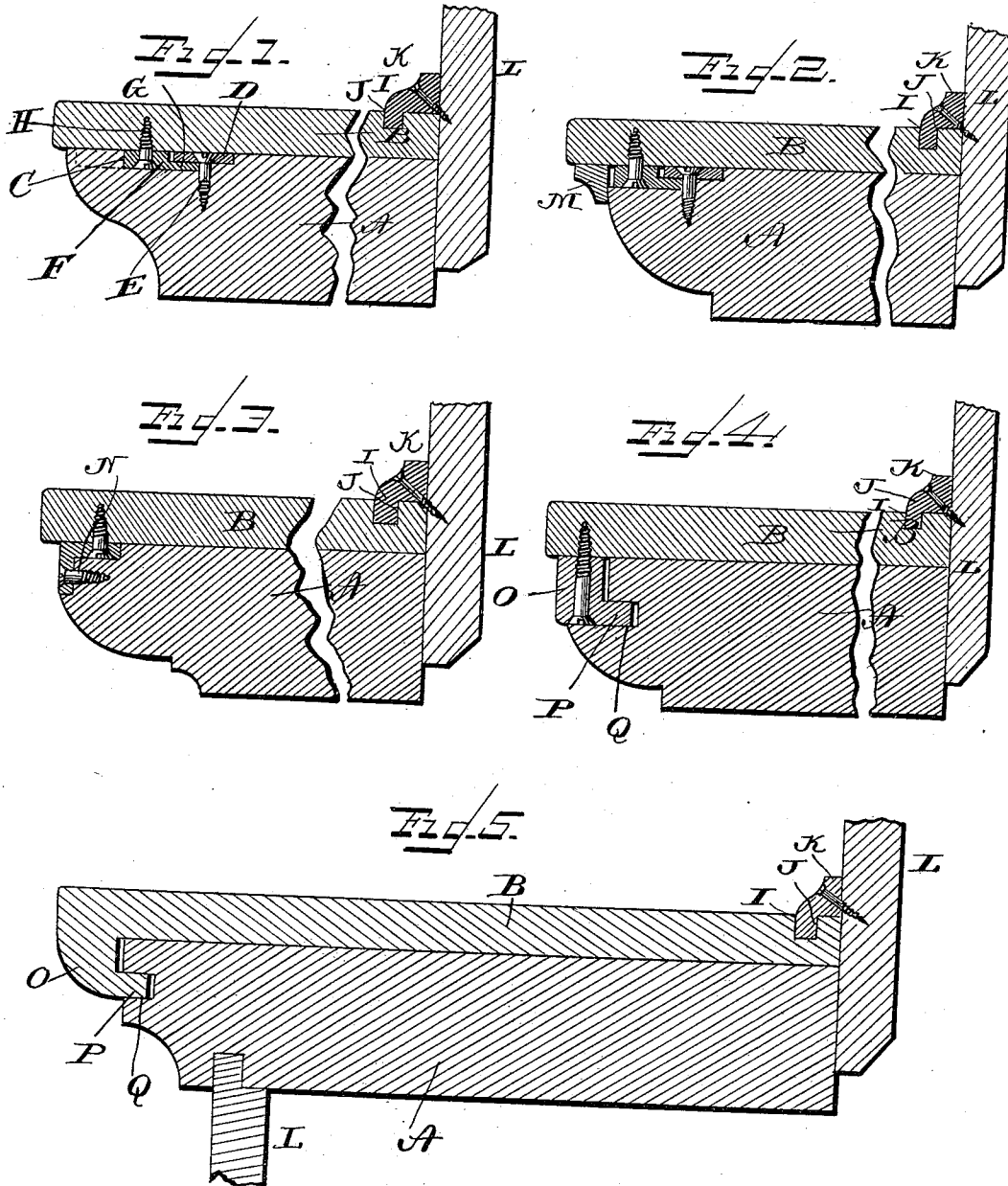

WITNESSES,
F. L. Ormand.
Geo. E. Erck.

Christian Momberg,
INVENTOR.
by Louis Daggner & Co.
Attorneys.

UNITED STATES PATENT OFFICE.

CHRISTIAN MOMBERG, OF COPENHAGEN, DENMARK.

TOP PLATE FOR STAIR-STEPS.

SPECIFICATION forming part of Letters Patent No. 381,407, dated April 17, 1888.

Application filed November 11, 1887. Serial No. 254,898. (No model.) Patented in Denmark August 11, 1887.

To all whom it may concern:

Be it known that I, CHRISTIAN MOMBERG, a subject of the King of Denmark, residing at Copenhagen, in the Kingdom of Denmark, have invented certain new and useful Improvements in Top Plates for Stair-Steps, (for which I have been granted a patent in Denmark, August 11, 1887;) and I do declare the following to be a full, clear, and exact description of the invention, such as will enable others skilled in the art to which it appertains to make and use the same, reference being had to the accompanying drawings, and to the letters and figures of reference marked thereon, which form a part of this specification.

Figure 1 is a transverse vertical sectional view of a stair-step provided with my improved top plate. Fig. 2 is a similar view of a modified form of the same, showing the plate used for an old and worn-out step. Fig. 3 is a sectional view of a modified form of fastening, and Figs. 4 and 5 are similar views of two other modifications of the fastening.

The same letters of reference indicate the same or corresponding parts in all the figures.

My invention has relation to steps for stairs; and it consists in the improved construction and combination of parts of a top plate for stair-steps and the means for securing the same to the steps, as hereinafter more fully described and claimed.

In the accompanying drawings, the letter A indicates the step, and B indicates the top plate, which is preferably made of a harder and more finely-finished wood than the step.

The upper side of the step is formed with grooves or recesses C, extending from near or at the outer edge of the step, and the inner ends of these grooves or recesses are covered by means of plates D of metal secured flush with the face of the step by means of screws E.

Plates F, having lips G upon their inner edges engaging the plates covering the inner ends of the recesses, are secured by means of screws H to the under side of the top plate, and it will be seen that when the top plate is placed upon the top of the step, and the lipped plates are placed in the outer ends of the recesses, the lips may be brought to engage under the plates in the recesses, when the top plate is pushed inward upon the step. For

the purpose of now securing the top plate from being pushed forward again and thus becoming disengaged from its fastenings, the upper side of the top plate has a groove, I, near the inner edge, which is engaged by a tongue, J, upon a strip, K, secured to the vertical face L of the next step above, and it will be seen that the top plate can only be removed by removing the strip, when the top plate may be pushed out and have its fastenings disengaged.

When the top plate is used upon a step which is worn, and upon which the plate will consequently not fit perfectly tight, the forward edge of the top plate is provided with a strip, M, secured to the under side of the top plate at the edge of the same, and to the forward edge or face of the step, the said strip covering the uneven joint between the under side of the top plate and the upper side of the step, as plainly shown in Fig. 2 of the drawings.

In Fig. 3 is shown a modified form of fastener, in which the plate in the inner ends of the recesses is not used, and in which the lip upon the plates upon the top plate is substituted by a screw, N, which enters the forward edge of the step, the plate upon the top plate extending, preferably, along the entire length of the step and taking the place of the fasteners of the former form and of the covering-strip.

In Figs. 4 and 5 the angle-iron forming the fastening of the form just described is substituted by a rectangularly-shaped strip or cleat, O, upon the under side of the top plate at the outer edge, either integral with the top plate, as shown at Fig. 5, or secured to the plate, as shown in Fig. 4, and the tongue P of this cleat or strip engages a groove, Q, in the forward edge of the step. It will be seen that by employing these top plates the stairs may be originally built of inferior or soft wood, and may be used during the construction of the building without any covering, and when the building is finished, the top plates may be secured in position, showing no traces of usage, as steps having been used during the construction of a building will, and showing no nail-holes, nail-heads, screw-heads, or other marks, being perfectly smooth upon their upper sides.

The top plates may be painted, varnished,

veneered, or otherwise ornamented before they are placed in position, and may be either laid or relaid, one by one, so that they will not obstruct the passage upon the steps to any great extent while being laid.

When steps are worn, the top plates may be placed over them and will give the stairs the appearance of a new set of steps, and when one set of top plates is worn out another set may be substituted, the plates thus saving in both instances the cost of an entirely new set of steps.

Having thus described my invention, I claim and desire to secure by Letters Patent of the United States—

1. In combination with a common stair-step, a top plate having a fastening for securing the outer edge to the step, and having a tongued strip engaging a groove in the inner edge of the upper side and secured to the vertical face of the next step above, as shown and described.

2. In combination with a common stair-step, a top plate having a hook-shaped fastening engaging a correspondingly-shaped fastening in the step, and a strip secured to the vertical face of the next step above and engaging a groove at the inner edge of the top plate with its tongue, as shown and described.

3. In combination with a common stair-step, a top plate having an inwardly hook-shaped fastening upon its under side engaging a correspondingly-shaped outwardly-opening fastening in the step, and a suitable strip secured to the top plate at the inner edge and to the vertical face of the next step above, as shown and described.

4. The combination of a common stair-step, having grooves or recesses in its upper face near or at the outer edge, plates secured flush with the face of the step covering the inner ends of the grooves or recesses, a top plate for the step, and plates secured to the under side of the top plate and having inwardly-pointing lips engaging under the plates in the recesses, as shown and described.

5. The combination of a common stair-step,

having grooves or recesses in its upper face near or at the outer edge, plates secured flush with the face of the step covering the inner ends of the grooves or recesses, a top plate for the step, plates secured to the under side of the top plate and having inwardly-pointing lips engaging under the plates in the recesses, and a strip secured to the vertical face of the next step above and having a tongue engaging a groove in the upper face of the top plate near the inner edge, as shown and set forth.

6. The combination of a common stair-step, having grooves or recesses in its upper face near or at the outer edge, plates secured flush with the face of the step covering the inner ends of the grooves or recesses, a top plate for the step, plates secured to the under side of the top plate, and having inwardly-pointing lips engaging under the plates in the recesses, and a strip secured to the under side of the top plate at the outer edge of the same covering the joint between the top plate and the upper face of the step, as shown and set forth.

7. The combination of a common stair-step, having grooves or recesses in its upper face near or at the outer edge, plates secured flush with the face of the step covering the inner ends of the grooves or recesses, a top plate for the step having a downwardly-projecting strip or flange at its forward edge and having a groove in the upper face near the inner edge, plates secured to the under side of the top plate and having inwardly-projecting lips engaging under the plates in the inner ends of the recesses or grooves, and a strip secured to the vertical face of the next step above and having a tongue upon its lower edge engaging the groove in the top plate, as shown and described.

In testimony whereof I affix my signature in presence of two witnesses.

CHRISTIAN MOMBERG.

Witnesses:

OLUF SIGURD ANDERSEN,
VIGG. CONSTANTIN EHERTT.