

L. Phleger,

Reciprocating Steam Engine.

No. 103649.

Patented May 31. 1870.

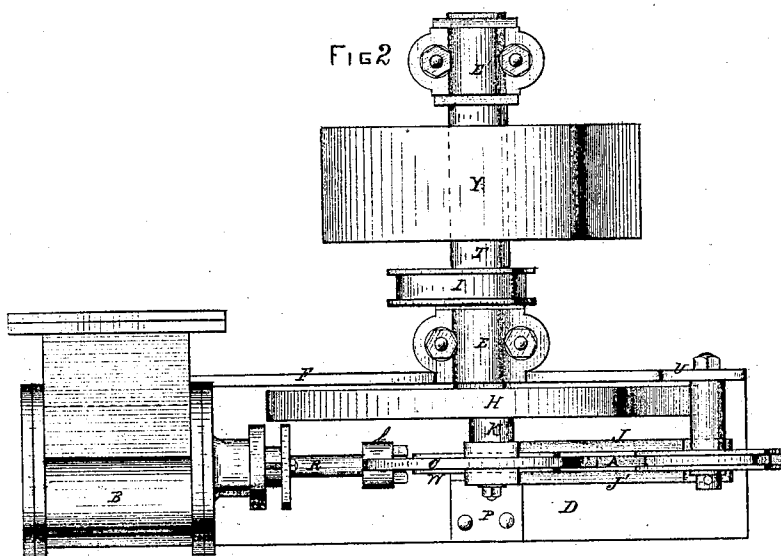
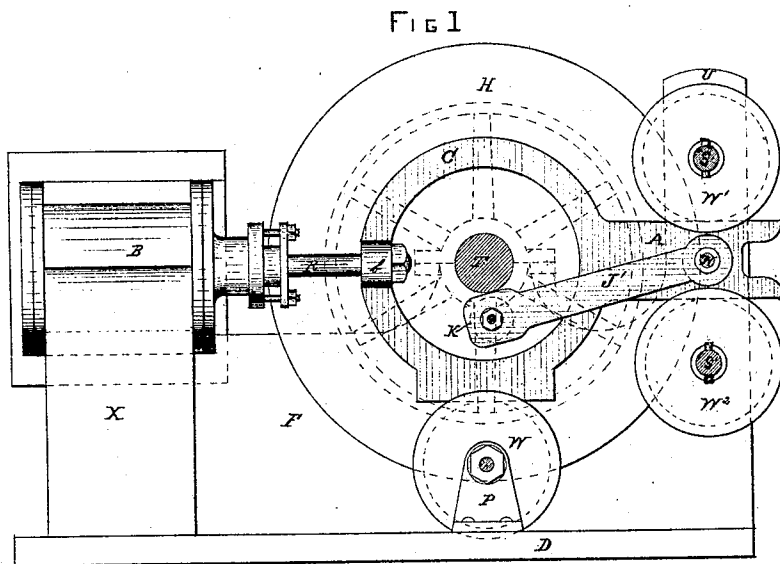

Witnesses: *Charles H. Evans*
George C. Nichols

Leonard Phleger } Inventor

United States Patent Office.

LEONARD PHLEGER, OF PHILADELPHIA, PENNSYLVANIA.

Letters Patent No. 103,649, dated May 31, 1870; antedated May 19, 1870.

IMPROVEMENT IN STEAM-ENGINE CONNECTIONS.

The Schedule referred to in these Letters Patent and making part of the same.

To all whom it may concern:

Be it known that I, LEONARD PHLEGER, of the city and county of Philadelphia and State of Pennsylvania, have invented a new and useful Improvement in Steam-Engines; and I do hereby declare that the following is a full, clear, and exact description of the construction and operation of the same, reference being had to the accompanying drawing and to the letters of reference marked thereon.

The object of my invention is to construct a steam-engine of a cheap, simple, and compact form, for either land or marine purposes, and dispensing with sliding surfaces in the cross-head and guides, whereby the friction of the moving parts is greatly reduced, so that increased power is gained with a saving of fuel.

The improvement consists in connecting with the piston-rod of the steam-cylinder a cross-head, made in the form of a circular ring, and provided with an arm or projection, and working on friction-wheels placed underneath the cross-head, and on the upper and lower edges of the arm, near the end, and on the opposite sides of the arm or projection are pivoted two connecting-rods, which extend back toward the steam-cylinder, and are attached to a crank-pin secured in a fly-wheel, the pin projecting out and working in the open space of the cross-head, as it (the cross-head) is reciprocated.

The bed-plate is made with a side extending up, so as to form a bearing for the main shaft, and a support for two of the friction-wheels.

Figure 1 is a side elevation of my improvement in steam-engines.

Figure 2 is a plan view of same.

The cross-head C, made in the form of a circular ring, and provided with an arm or projection, A, is connected to the piston-rod R by means of a boss, b, cast or formed on the rim, through which is passed and secured the end of the piston-rod. The said cross-head C is elevated, and works on friction-wheels W, W¹, and W², and is adjusted so that the center of it and the arm A is on a horizontal line drawn through the center of the cylinder B.

The wheel W is placed directly under the center of the cross-head, where it is centered in a pedestal, P, secured to the bed-plate D, and a portion of the lower edge of the cross-head made perfectly straight and fitted in a groove formed on the face of the wheel.

The upper and lower edges of the arm A fit in and work in grooves formed on the face of the wheels W¹ and W².

These wheels turn on studs S and S', so that the

cross-head is carried in a direct line with the piston-rod.

Centered on the opposite sides and near the outer end of the arm A, by means of the pin N, are two connecting-rods, J and J', the opposite ends of which extend back toward the steam-cylinder, and are secured together and work on a crank-pin, K, secured in the fly-wheel H, at a proper distance from the center of the driving-shaft T, so as to form a length of crank suitable to the size of the steam-cylinder. The crank-pin K, during its revolutions, describes a circle in the open space of the cross-head, without coming in contact with it.

The bed-plate D is cast in one piece, with a box, X, for supporting the cylinder B, and a side or framing, E, which extends up, and has formed on its upper edge a bearing, E, and an upright, U, in which a vertical slot is formed for securing and adjusting the studs S and S' of the wheels W¹ and W². On the back part of the bed-plate, which extends out the proper distance, is a pedestal, on the upper end of which is formed a bearing, E'.

Under the center of the bearings E and E', and on one side of the upright U, are formed ribs, for supporting and giving additional stiffness to the said parts.

The main shaft T is placed and revolves in the bearings E and E', and is provided, on its front end, with a fly-wheel, H, and, between the bearings, with a driving-pulley, Y, and an eccentric, I.

In setting the engine, the center of the cylinder, driving-shaft, and cross-head, are placed on a horizontal line, so that the piston-rod and the arm of the cross-head are always carried, and the full power of the engine delivered on a parallel line on the in-and-out stroke of the piston, and the rolling motion of the wheels W¹ and W² on the upper and lower edges of the arm A diminishes the friction, so that increased power is gained.

The wheel W placed under the center of the cross-head, gives additional support to it, and prevents the wearing away (caused by the weight of the cross-head bearing on the piston and rod) of the lower side of the cylinder, stuffing-box, and gland.

The brasses in the connecting-rods J and J' can be adjusted by means of set-screws inserted in the ends of the rods.

I do not claim the friction-wheels W, W¹, and W², as I am aware that they have been known and used for purposes similar to what I have applied them to, and intended to produce the same result.

Having thus described my invention, its construction and operation,

What I claim, and desire to secure by Letters Patent of the United States, is—

1. The construction and arrangement of the cross-head C and connecting-rods J and J', as and for the purpose specified.

2. The construction and arrangement of the bed-plate D, frame F, box X, upright U, bearings E and E', shaft T, fly-wheel W, and crank-pin K, substantially in the manner and for the purpose herein set forth.

3. The within-described steam-engine, composed of the parts herein set forth, all combined and operating as specified.

In testimony whereof I have hereunto signed my name in the presence of two subscribing witnesses.

LEONARD PHELEGER.

Witnesses:

CHARLES H. EVANS,
ISAAC R. OAKFORD.