

H. ROWNTREE.
 CUSHION MECHANISM FOR PNEUMATIC DOOR CONTROL DEVICES.
 APPLICATION FILED MAR. 18, 1908.

1,001,988.

Patented Aug. 29, 1911.

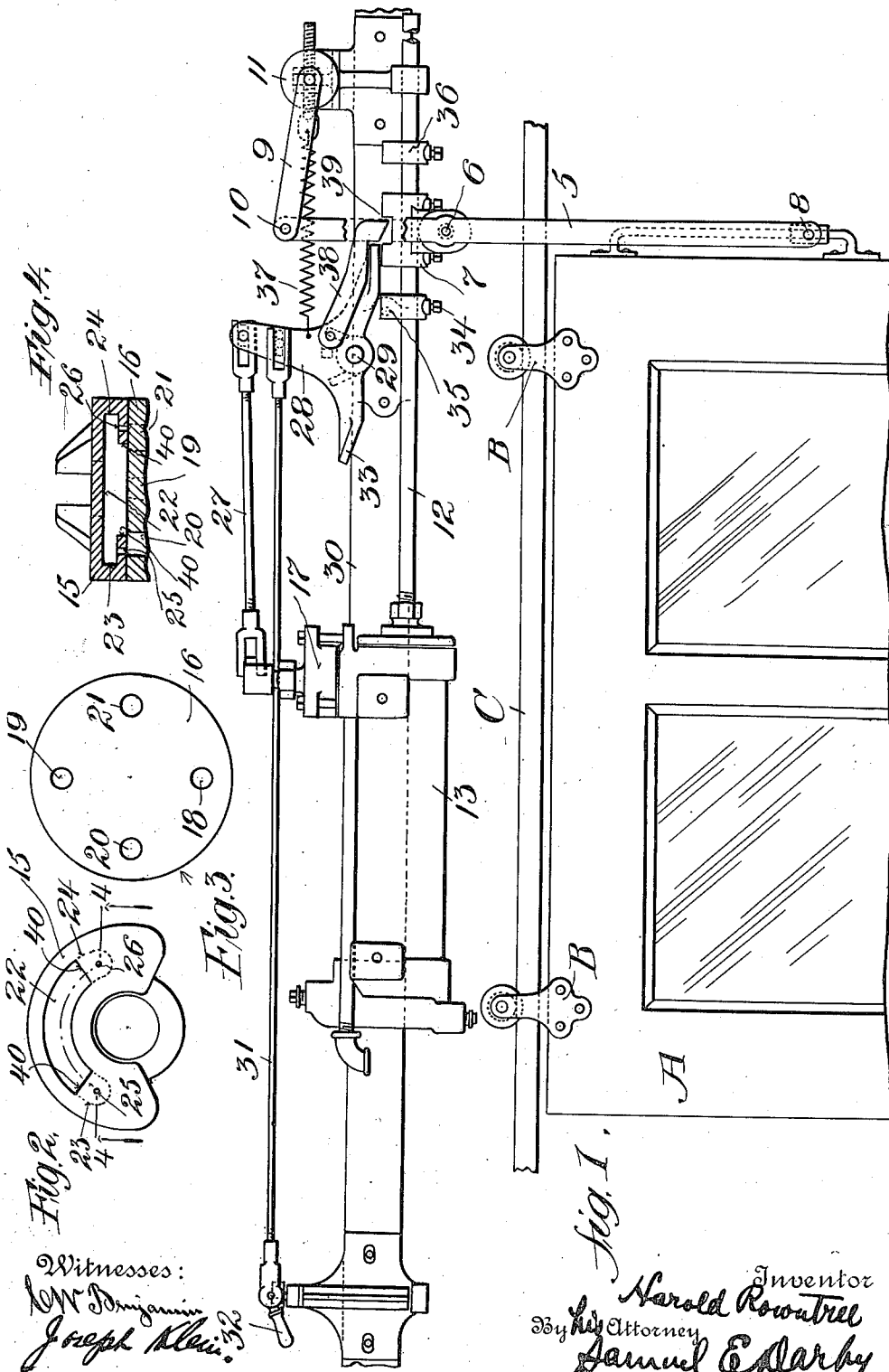

Witnesses:
 E. J. Benjamin
 Joseph Allen

Inventor
 Harold Rowntree
 By his Attorney
 Samuel E. Parby

UNITED STATES PATENT OFFICE.

HAROLD ROWNTREE, OF CHICAGO, ILLINOIS, ASSIGNOR, BY MESNE ASSIGNMENTS, TO NATIONAL PNEUMATIC COMPANY, A CORPORATION OF WEST VIRGINIA.

CUSHION MECHANISM FOR PNEUMATIC DOOR-CONTROL DEVICES.

1,001,988.

Specification of Letters Patent.

Patented Aug. 29, 1911.

Application filed March 18, 1908. Serial No. 421,807.

To all whom it may concern:

Be it known that I, HAROLD ROWNTREE, a citizen of the United States, residing at Chicago, county of Cook, State of Illinois, have made a certain new and useful Invention in Cushion Mechanism for Pneumatic Door-Control Devices, of which the following is a specification.

The invention relates to cushion mechanism for pneumatic door control devices.

The object of the invention is to provide means which are simple and efficient for cushioning the closing or opening movements of pneumatically controlled doors or other closures.

A further object is to provide means for adjustably regulating the point at which the cushioning operations commences.

Other objects of the invention will appear more fully hereinafter.

The invention consists substantially in the combination, location, and relative arrangement of parts, all as will be more fully hereinafter set forth, as shown in the accompanying drawing, and finally pointed out in the appended claims.

Referring to the accompanying drawing and to the various views and reference signs appearing thereon: Figure 1 is a view in elevation, parts broken off, of pneumatic door control devices showing the application thereto of adjustable cushioning mechanism embodying the principles of my invention. Fig. 2 is a bottom plan view of the valve employed in connection with the door operating and cushioning devices. Fig. 3 is a top plan view of the valve seat. Fig. 4 is a view in section on the line 4, 4, Fig. 2, showing the valve and its seat in assembled relation.

The same part is designated by the same reference sign wherever it occurs throughout the several views.

In the drawing reference sign A, designates a door which may be of any suitable or desired construction. For purposes of illustration I have shown a door of the sliding type, said door being suspended on hangers B, from a track C, in the ordinary manner. The door may be moved along its supporting track in many specifically different ways. In the particular form shown a lever 5 is pivotally mounted, as at 6, upon a bracket or collar 7, has sliding connection

at one end as at 8, to the door. The other end of said lever is connected by a link 9, which is pivotally connected to said lever as at 10, and to a fixed bracket 11. The lever 5, may be rocked in any suitable or convenient manner to effect the desired operation of the door. In the particular form shown the bracket or collar 7, upon which the lever 5, is pivoted, is carried by the piston rod 12, of a piston arranged to operate in a cylinder 13, to which compressed air or other operating medium may be supplied, the supply of such medium being controlled in any suitable or convenient manner. In the form shown, the supply and exhaust of operating medium, in this instance compressed air, to and from the respective ends of the cylinder 13, is controlled by a valve 15, cooperating with a valve seat 16, arranged within a casing 17. The valve seat is provided with an air supply port 18, an exhaust port 19, and ports 20, 21, leading to or communicating with the respective ends of the cylinder 13. The valve 15, is provided in the face thereof which rests upon the upper surface of the valve seat, with a depressed chamber 22, which extends in the direction of the arc of a circle struck from the axial center of the valve. At each end the chamber 22, is recessed as at 23, 24, the inner walls of said recesses having, respectively, the small openings or passages 25, 26, therethrough. The valve 15, may be axially rocked in any suitable or convenient manner, as, for instance, by means of a rod 27, connected at one end to the stem of said valve, and at the other end to the rock lever 28, pivotally mounted, as at 29, to a fixed part 30, of the supporting frame work. This rock lever may be rocked to move the valve in many different ways. I have shown an operating rod 31, connected to the rock lever 28, and I arrange said rod to be operated by a hand lever 32 whereby the valve may be manually operated to admit the operating medium to either end of the cylinder and to permit the air confined in the opposite end of the cylinder to escape to exhaust.

The operation will be readily understood and is as follows: Suppose the parts to be in the position shown in the drawing and the door closed. The handle 32 is manipulated to rock lever 28, toward the left, thereby,

through rod 27, rotatively moving the valve 15, so as to uncover the port 21, thereby admitting pressure from the supply port 18 through port 21, to the right hand end of the cylinder 13, the left hand end of the cylinder being, at the same time, opened freely to exhaust through port 19, said exhaust port being at all times in communication with said chamber 22. Under these conditions the piston in the cylinder 13 moves toward the left hand end of said cylinder, thereby, through the connection of the piston rod 12, with the door operating-lever 5, rocking the latter, and hence moving the door toward the left.

As the door approaches the limit of its movement it is desirable to provide means for cushioning it. To accomplish this result I provide means for imparting a limited reverse rotative movement to the valve but of sufficient extent to cause the face of the inner wall of recess 23, of the valve to cover the exhaust port 20 from the left hand end of the cylinder. Thereafter the exhaust from said end of the cylinder can only be effected through the very small opening or passage 25, through said wall, thereby restricting the exhaust and consequently slowing down and cushioning the final movement of the door and enabling it to be brought to a smooth, easy stop. The means by which this reverse movement of the valve is accomplished may be varied throughout a wide range. I have shown an exceedingly simple arrangement wherein I provide the rock lever 28 with arms 33, 34, extending in opposite directions from the axis about which said lever rocks, and in position to be engaged by a collar or other convenient member 35, 36, connected to move with the piston rod 12, or other suitable moving part of the apparatus. In the example above given, as the piston rod moves toward the left the collar 35, engages the arm 33, of the rock lever 28, and reversely tilts or rocks said lever from the position to which it had been actuated by the manipulation of the hand lever 32, sufficiently far to cause the valve 15 to be reversely rotated to cause the port 20 to exhaust through the restricted opening 25, in the valve as above explained.

In order to prevent the valve from being brought to a dead center position during the cushioning operation, the distance between the small opening or passage 25, or 26, and the edge 40, of the inner walls of the recesses 23, 24, should be slightly less than the diameter of the ports 20, 21. By suitably adjusting the collar or other movable part 35, the point at which this reverse movement of the valve takes place may be adjustably regulated, thereby adjustably regulating the point at which the cushioning effect takes place. I regard this feature of adjustably regulating the point at which the

cushioning effect commences as a most important and valuable feature of my invention.

If desired, the parts may be normally held in such position as to maintain the door in one or the other of its limits of movement. This result is accomplished, in the particular form shown, by applying a retracting spring 37 to the rock lever 28, to normally maintain the same in one limit of its rocking movement.

If desired, and in order to prevent leakage of the air pressure into the operating cylinder from moving the door, or, in order to lock the door in one or the other limits of its movement, I provide a locking latch 38, and arrange the same to engage in a recess 39, in the bracket or collar 7. The latch 38, carried by the rocking lever 28, which, when rocked by the manipulation of the hand lever 32, causes said latch to be lifted out of the recess 39, to permit the door to be opened.

It is to be understood that variations and changes in the details of construction and arrangement of parts would readily occur to persons skilled in the art and still fall within the spirit and scope of my invention. I do not desire therefore, to be limited or restricted to the exact details shown and described. But

Having now set forth the object and nature of my invention and a construction embodying the principles thereof, and having described such construction, its purpose, function and mode of operation, what I claim as new and useful and of my own invention, and desire to secure by Letters Patent is:—

1. In a pneumatic door control device, a motor, a valve chamber having ports respectively communicating with a source of pressure supply and with opposite sides of the motor, and also having an exhaust port, a valve for controlling said ports, means for moving the valve into position to freely uncover the full exhaust from one side of the motor, while admitting full pressure to the other side of the motor, means operated by the motor for shifting the valve in reverse direction to restrict the exhaust area without substantially restricting the pressure supply to the other side of the motor, means for adjustably regulating the point at which the reverse movement of the valve commences, and door operating devices actuated by said motor.

2. In a pneumatic door operating mechanism, a motor, a valve chamber having ports respectively communicating with a source of pressure supply and with opposite sides of the motor, and also having an exhaust port, a valve for controlling said ports, said valve arranged, when at the limit of its movement in either direction, to open full com-

5 munication between a motor port and the
 exhaust port, and to fully open the other
 motor port to pressure supply, whereby one
 side of the motor is opened to pressure sup-
 10 ply and the other side to full exhaust, means
 for moving the valve to the limits of its
 movement, means operated by the motor for
 moving the valve in reverse direction, means
 whereby the reverse movement of the valve
 15 reduces the area of exhaust without sub-
 stantially affecting the pressure supply,
 means for adjusting the point at which the
 reduction in exhaust area commences, and
 door moving devices actuated by the motor.
 20 3. The combination in a pneumatic door
 operating mechanism, of a motor, a valve
 arranged to control the supply of pressure
 medium to, and its exhaust from, said mo-
 tor, means for shifting the valve into po-
 25 sition to open the motor on one side to full
 supply of pressure, and on the other side to
 full exhaust, to initiate the operation of the
 motor, means operated by the motor to re-
 versely shift the valve into position to re-
 30 duce the exhaust to a constant predetermined
 area without substantially affecting the sup-
 ply of pressure, means for adjusting the
 point at which the reduction of exhaust area
 commences, and door operating devices ac-
 tuated by the motor.

4. The combination, in a pneumatic door operating mechanism, of a motor, a valve

chamber having ports respectively commu-
 nicating with a source of pressure supply,
 with opposite sides of the motor, and with
 35 exhaust, a valve to control said ports, said
 valve arranged, when in either limit of its
 movement to fully open one motor port to
 the pressure supply port, and having a re-
 cess to embrace within its length the other
 40 motor port and the exhaust port, said recess
 having an overhanging wall or lip at each
 extremity thereof said wall or lip having a
 restricted passage delivering to said recess,
 means for shifting the valve into its extreme
 45 limit of movement of the motor, means op-
 erated by the motor to reversely shift the
 valve to bring said wall or lip passage into
 register with the exhausting motor port,
 thereby reducing the exhaust area without
 50 substantially affecting the area of pressure
 supply to the other motor port, means for
 adjustably regulating the point at which the
 reverse movement of the valve commences,
 and door operating devices actuated by the
 55 motor.

In testimony whereof I have hereunto set my hand in the presence of the subscribing witnesses, on this 6th day of March A. D. 1908.

HAROLD ROWNTREE.

Witnesses:

I. LEVINSON,
JOSEPH KLEIN.