



- (51) International Patent Classification:
A61F 5/448 (2006.01)
- (21) International Application Number:
PCT/US2012/025225
- (22) International Filing Date:
15 February 2012 (15.02.2012)
- (25) Filing Language: English
- (26) Publication Language: English
- (30) Priority Data:
13/031,379 21 February 2011 (21.02.2011) US
- (71) Applicant (for all designated States except US): **INTERNATIONAL MEDICAL TECHNOLOGY, INC.**
[US/US]; P.O. Box 1533, Temecula, California 92593 (US).
- (72) Inventor; and
- (75) Inventor/Applicant (for US only): **SALAMA, Fouad A.**
[US/US]; P.O. Box 1533, Temecula, California 92593 (US).
- (74) Agent: **COLEMAN, Kyle S.**; McKee, Voorhees & Sease, P.L.C., 801 Grand Avenue, Suite 3200, Des Moines, Iowa 50309-2721 (US).

(81) Designated States (unless otherwise indicated, for every kind of national protection available): AE, AG, AL, AM, AO, AT, AU, AZ, BA, BB, BG, BH, BR, BW, BY, BZ, CA, CH, CL, CN, CO, CR, CU, CZ, DE, DK, DM, DO, DZ, EC, EE, EG, ES, FI, GB, GD, GE, GH, GM, GT, HN, HR, HU, ID, IL, IN, IS, JP, KE, KG, KM, KN, KP, KR, KZ, LA, LC, LK, LR, LS, LT, LU, LY, MA, MD, ME, MG, MK, MN, MW, MX, MY, MZ, NA, NG, NI, NO, NZ, OM, PE, PG, PH, PL, PT, QA, RO, RS, RU, RW, SC, SD, SE, SG, SK, SL, SM, ST, SV, SY, TH, TJ, TM, TN, TR, TT, TZ, UA, UG, US, UZ, VC, VN, ZA, ZM, ZW.

(84) Designated States (unless otherwise indicated, for every kind of regional protection available): ARIPO (BW, GH, GM, KE, LR, LS, MW, MZ, NA, RW, SD, SL, SZ, TZ, UG, ZM, ZW), Eurasian (AM, AZ, BY, KG, KZ, MD, RU, TJ, TM), European (AL, AT, BE, BG, CH, CY, CZ, DE, DK, EE, ES, FI, FR, GB, GR, HR, HU, IE, IS, IT, LT, LU, LV, MC, MK, MT, NL, NO, PL, PT, RO, RS, SE, SI, SK, SM, TR), OAPI (BF, BJ, CF, CG, CI, CM, GA, GN, GQ, GW, ML, MR, NE, SN, TD, TG).

Declarations under Rule 4.17:

— as to applicant's entitlement to apply for and be granted a patent (Rule 4.17(ii))

[Continued on next page]

(54) Title: FLOW CONTROL AND COLLECTION DEVICE

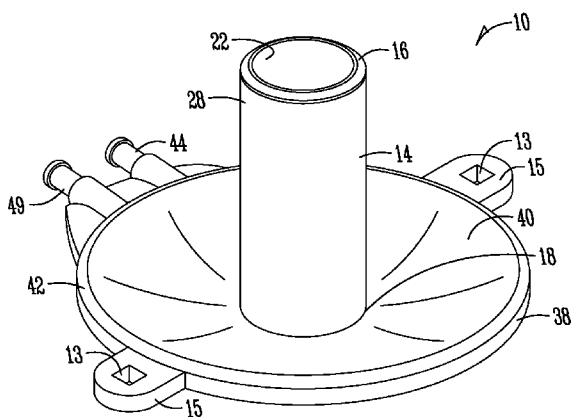

Fig. 2A

(57) Abstract: A flow control and collection system includes a flow control device having a tubular member in which an inflatable balloon is positioned about the circumference of the interior side wall for closing the passageway to movement of matter and liquid when the balloon is expanded and allowing flow when the balloon is contracted against the side wall to which it is attached. The flow control device includes an adapter at the outer end of the tubular member having one or more interlocking features. A waste collection bag has a sealed body with at least one opening and a flow control device adapter at the opening having one or more counterpoising interlocking features to removably lock the adapters together and passes waste material and liquid through the flow control device into the waste collection bag.



Published:

- *without international search report and to be republished upon receipt of that report (Rule 48.2(g))*

TITLE: FLOW CONTROL AND COLLECTION DEVICE**BACKGROUND OF THE INVENTION**

5 Persons requiring ostomy procedures or being incontinent have need for a flow control and collection device that will not leak or accidentally separate, and is simple to install, operate and remove.

SUMMARY OF THE INVENTION

10 The flow control and collection device of this invention meets the needs of persons having had an ostomy procedure to address incontinency issues, or are fecally incontinent. The flow control and collection devices of this invention can be positioned in a body opening such as a stoma or around the anus. For example, persons requiring a colostomy or ileostomy have need for a flow control and collection device of the present invention.

15 In one aspect of the invention, a flow control and collection system for human excretions is disclosed. The flow control device includes a tubular member having inner and outer ends interconnected by a passageway adapted for insertion into a body opening. An adapter at the outer end of the tubular member has one or more interlocking features. A collection bag that has a sealed body and at least one opening also includes a adapter
20 having one or more counterpoising interlocking features to removably lock the device and bag adapters together.

A device providing flow control for human excretions is also disclosed. The device includes a tubular member having inner and outer ends connected by a passageway and the inner end adapted for insertion into a body opening. An adapter is included at the outer end
25 of the tubular member having a plurality of radially spaced interlocking features formed in the adapter.

A bag for collecting human excretions is also disclosed. The bag includes a sealed body having at least one opening and an adapter attached to the body around the opening. The adapter includes a generally planar surface and a plurality of radially spaced
30 interlocking features. The interlocking features removably lock the bag to a device having an inner end adapted for insertion into a body opening.

In another aspect of the invention, a flow control device for human excretions is disclosed. The device includes a tubular member having inner and outer ends interconnected by a passageway. The tubular member has a discontinuous side wall and the inner end of the tubular member is adapted for surgical attachment at a body opening.

5 The device also includes a plurality of tube diameter adjustment points spaced opposite one another on opposing sides of the discontinuity in the side wall and a tether between opposing adjustment points to adjust the diameter of the passageway to the size of the body opening.

10 **BRIEF DESCRIPTION OF THE DRAWINGS**

Figure 1 is a fragmentary side view of a flow control device of this invention being positioned in a body opening of a person.

Figures 2A-B are perspective views of embodiments of the flow control device shown in Figure 1.

15 Figure 3 is a cross-sectional view of a flow control device positioned in a body opening.

Figure 4 is an end elevation view of the flow control device.

Figure 5 is a front elevation view of a collection bag of this invention.

20 Figure 6 is a view similar to Figure 3 but showing adapters connecting the flow control device and waste collection bag.

Figure 7 is a perspective view of a bagless device of this invention.

Figure 8 is a perspective view of another flow control device of this invention for surgical attachment at a body opening.

25 **DETAILED DESCRIPTION OF THE PREFERRED EMBODIMENTS**

The flow control device of this invention is referred to generally in Figure 1 by the reference numeral 10 and is shown positioned in a body opening, such as a stoma, on a the side of a person 12. The device 10 may be positioned in another body opening, such as the rectum of the person 12. The device 10 may be used, for example, by those having had a
30 colostomy or ileostomy.

In Figures 2A-B, the flow control device 10 includes a tubular body member 14 having inner and outer ends 16 and 18, and on opposite sides of a body opening 19 (see Figure 3) when installed. The tubular body member 14 may include one or more wall stiffeners to support the tubular member 14 against collapsing. In one aspect of the invention, the tubular member 14 includes an internal wall stiffener such as a rigid tube enclosed by the inner and outer skins of the tubular member 14. One example of a rigid tube includes polycarbonate tubing, or other tubing of sufficient strength to prevent the tubular member 14 from collapsing. Other types of stiffeners include the wire frame 30 discussed below. A wafer 40 in the form of a flange is connected to the outer end 18 of the tubular member 14. The inner surface 40 of wafer 42 may include a concave profile, with the depth of the profile decreasing from proximate the outer end 18 of the tubular member 14 outward to the outer peripheral edge of the wafer 42. The concavity of the inner surface 40 of wafer 42 prevents the inner surface 40 of wafer 42 from compressing or putting pressure on the tissue or mucosa 17 around the body opening 19, such as would be present in the case of a colostomy or ileostomy. A device adapter 38 is included on the side of wafer 42 opposite the inner surface 40 and further described below. The device adapter 38 includes a pair of ears 15 extending generally perpendicularly outward from the outer peripheral edge of the adapter 38. Each ear 15 includes an attachment point 13, such as a hole extending through the ear 15. An ostomy belt, such as are well known in the art, may be used to strap the device 10 to the person 12 by hooking ends of the belt to the attachment points 13.

In Figure 3, a balloon valve 20 is attached to the interior side wall 22 of the tubular member 14 and is inflated and deflated through a passageway 24 in the tubular member side wall 22. The balloon valve 20 is attached radially (i.e., 360 degrees) about the interior side wall 22 of the passageway 24. When the valve 20 is inflated, the balloon expands radially inward away from the interior side wall 22 of the passageway 24 toward the center of the passageway 24 in sealing engagement with itself. The balloon valve 20 seals closed the passageway 24 to prevent the flow of matter and fluid through the passageway 24 when the balloon valve 20 is inflated. The balloon valve 20 of the present invention is shown and described in a commonly owned application, Application Serial 11/464,686 filed August 15, 2006, incorporated by reference herein in its entirety.

An expandable membrane 28 is attached at the inner end 16 of the tubular member 14, and in one aspect of this invention the interior side wall 22 is supported against being collapsed when the membrane 28 is inflated by a wire frame 30 (see Figure 2B). The wire frame 30 is preferably positioned within the interior side wall 22 or secured to the interior side wall 22 to provide stiffness and rigidity to at least that portion of the side wall 22 supporting the pressure resulting from expansion of the expandable membrane 28 as shown in Figure 3. In the case where the body opening 19 is generally smaller (e.g., such as with an ileostomy opening or chronic colostomy patients) the wire frame 30 may be collapsed or pinched to reduce the diameter of the inner end 16 of the tubular member 14 to facilitate insertion within a smaller body opening. The wire frame 30 may be configured to hold the collapsed position for an increment of time (e.g., the time needed to fully insert the inner end 16 in the body opening 19) and resume or expand to its original, pre-collapsed position after the increment of time has elapsed. For example, the wire frame 30 may include a memory which causes it to return to its original, pre-collapsed position from a collapsed or pinched position. After insertion of the device 10 and the wire frame 30 resuming its original, pre-collapsed position, the wire frame 30 supports the interior side wall 22 or tubular member 14 against collapsing when the expandable membrane 28 is inflated. In one aspect of the invention, the wire frame 30 comprises a nickel titanium alloy, such as Nitinol, having one or more memorized positions. The wire frame 30 may also be stainless steel, such as surgical grade stainless steel. Embodiments of this invention using the expandable membrane 28 with or without the wire frame 30 are contemplated. For example, the device 10 could include other types of stiffeners, such as those discussed above, to prevent the tubular member 14 from collapsing. As passageway 32 in the side wall of the tubular member 14 connects with the expandable membrane 28, the pressure applied to the expandable membrane 28 may of course vary as required to form a seal at the interface 34 between the expandable membrane 28 and the interior wall 36 surrounding the body opening 19 and retain the device 10 in the opening 19. For example, in the case of a colostomy or ileostomy, the expandable membrane 28 may be expanded to form a seal at the interface 34 between the interior wall surface 36 of the intestine and the expandable membrane as shown in Figure 3.

In Figure 4, a device adapter 38 is provided either in the wafer 42 or attached to the outer end 18 of the tubular member 14, or attached to the outer surface 41 of wafer 40. The device adapter 38 or wafer 42 includes laterally outwardly extending tube portions 46 and 48 terminating at or near the outer peripheral edge of the wafer 42 or bag adapter 38 in self-sealing micro valves 44 and 49, such as check valves (see Figure 3). The tube portions 46 and 48 connect respectively to passageway 24 and 32 in the side wall 22 for inflating and deflating the balloon valve 20 and expandable membrane 28 respectively, using for example a syringe. The device adapter 38 has a generally planar outer surface and includes an aperture 50 coinciding with the outer end 18 of the tubular member 14. Spaced radially in, on or through the device adapter 38 is a plurality of interlocking features 52. In a preferred form of this invention, the interlocking features 52 include one or more geometries that provide a twist and lock type connection. In one aspect, the interlocking features 52 include a plurality of keyways 53 radially spaced about the aperture 50 in the device adapter 38.

The device 10 may include a cap 66 having counterpoising interlocking feature 68 radially spaced about a plug 72 sized to occupy the aperture 50 in the device adapter 38 when the cap 66 is secured to the device adapter 38. The counterpoising interlocking features 68 preferably include a plurality of one or more geometries configured to interlock, such as by use of a twist and lock action, with the interlocking features 52 of the device adapter 38 by gripping the rib 74 on the flow control device cap 66, joining the interlocking features 52 and 68 together, and twisting the cap 66 to lock the cap 66 to the device adapter 38. In one aspect of this invention, the counterpoising interlocking feature 68 on the cap 66 include a plurality of keys 70 radially spaced about plug 72. The keys 70 provide a male contact having geometries commensurate with the counterpoising female contacts configured in the device adapter 38 so that the keys 70 are received within the keyways 53 to removably lock cap 66 over the aperture 50 of device adapter 38. A tether 76 may be included on the device adapter 38 attached to cap 66 for keeping it tethered to the adapter 38 when not in use. The interlocking features 52 and 66 in the adapter 38 and cap 66 prevent the cap from inadvertently or accidentally becoming separated from the adapter 38. This invention contemplates that the female or male configuration of the interlocking features 52 and 68 may be switched between the adapter 38 and the cap 66.

A waste collection bag 58 is illustrated in Figures 5-6. The waste collection bag 58 is formed of a disposable sealed body 64. The sealed body 64 may include a vent 62 for allowing gases to vent from the body. The bag 58 also includes a central opening 60 surrounding circumferentially by a bag adapter 56. The bag adapter 56 is a generally planar wafer-shaped member and may be included in or attached to the sealed body 64 of the bag 58. The bag adapter 56 is also preferably a semi or fully rigid component, and hence constructed of a semi or fully rigid material. The adapter 56 is preferably more rigid than the bag 58 material. Spaced radially about opening 60 either in or on the bag adapter 56 is a plurality of counterpoising interlocking features 68. In one aspect of this invention, the features 68 include a plurality of keys 70 radially spaced about opening 60. The keys 70 are raised a distance off the surface of the adapter 56 to provide a gap between the key and the adapter surface as best illustrated in Figure 3. The key 70 may include one or more geometries providing a twist and lock function when inserted through a plurality of corresponding keyways, such as the keyways 53 illustrated in the device adapter 38 shown in Figure 4 or the plurality of keyways 82 shown in the bag cap 78. Although the keys 70 illustrate a specific embodiment of the counterpoising interlocking feature 68 of the present invention, other interlocking features are contemplated. For example, various male and corresponding female features or contacts are contemplated that would allow for a twist and lock function whereby the adapters and caps of the present invention are removably locked together. In another aspect of the invention, the waste collection bag 58 includes a cap 78 that may, in one example, be secured by a tether 88 to the bag adapter 56. The cap 78 includes a plug 84 extending generally perpendicularly and outwardly from the surface of the cap 78 and having a diameter corresponding to the opening 60 in the bag adapter 56. Radially spaced about the plug 84 is a plurality of interlocking features 80. The interlocking features 80, in one aspect of the invention, comprise keyways 82 configured in the bag cap 78. The outer peripheral edge of the cap 78 may include one or more cogs 86 to facilitate gripping, manipulating and turning the cap 78 into a removably locked position onto the bag adapter 56. This is accomplished by aligning the keys 70 of the bag adapter 56 with the keyways 82 in the cap 78, inserting the keys 70 through the keyways 82, and rotating the bag cap 78 either clockwise or counterclockwise depending upon the orientation of the keys 70 on the bag adapter 56. When the cap 78 is removably locked to

the bag adapter 56, the plug 84 occupies the spaced defined by opening 60 in the bag adapter 56. The bag 58 is thereby sealed and may be disposed of. Gas venting membranes may be included within vent 62, or in a vent-type plug 84. The membrane may comprise a charcoal filter for filtering and deodorizing gases escaping from the bag 58. In another
5 aspect of the invention, the waste collection bag 58 includes an entirely sealed body 64 having only the single opening 60 in the bag adapter 56. The bag cap 78 includes a filter, such as for example within an opening in the plug 84, to allow gases to escape from the bag 58 through the opening in the plug 84. As illustrated in Figure 6, the bag adapter 56 mates flush with the device adapter 38 on the flow control device 10. The counterpoising
10 interlocking feature 68 of the bag adapter 56 engage the interlocking features 52 in the device adapter 38. The bag 58 is rotated to thereby removably lock the adapters 56 and 38 together, thereby placing the flow control device 10 in communication with the opening 60 in bag 58. The balloon valve 20 is deflated and waste material and fluids are permitted to flow from the body through the flow control device 10 into the waste collection bag 58.
15 The balloon valve 20 is reinflated to close the device 10 and the waste collection bag 58 is disconnected from the flow control device 10; the flow control device cap 66 may also be used to cap off the flow control device 10.

A bagless device 90 suitable for removable attachment to the flow control device 10 is shown in Figure 7. The bagless device 90 includes an adapter 92 having a plurality of
20 counterpoising interlocking features 94 radially disposed about the opening 97. In one aspect of this invention, the counterpoising interlocking feature 94 comprises keyways 95 similar to those discussed above. The bagless device 90 includes an outwardly and downwardly extending tube 96 having an opening or inlet 97 and an outlet end 98. The outlet end 98 is tapered, having a generally smaller diameter than the inlet end 97. A
25 degradable tubular sleeve 100 is provided having an inlet opening 102 and an outlet opening 104. The inlet opening 102 may have a diameter generally larger than the outlet end 98 of tube 96 but smaller than the overall average diameter of the tube 96 so as to form a friction fit between the inlet opening 102 of the degradable tubular sleeve 100 and the
30 outlet end 98 of tube 96 when the inlet opening 102 of the sleeve 100 is slid over the outlet end 98 of tube 96. The sleeve 100 may have the same diameter inlet opening 102 as the outlet opening 104 so that the inlet opening 102 is slightly deformed, such as by stretching,

to secure it to the outlet end 98 of tube 96. In use, the counterpoising interlocking features 94 mate with the interlocking features 52 of the device adapter 38 (illustrated in Figure 4). Thus, the bagless device 90 twists and removably locks to the flow control device 10 to allow material and fluid to pass through the flow control device 10, flange tube device 90 and disposable tubular sleeve 100. The sleeve 100 is sufficiently flexible to allow manipulation of the outlet opening 104 to a desired location for dispensing waste material and fluids into a device such as a toilet when standing or seated. The tubular sleeve 100 may be disposed of after each use and the flange tube device 90 cleansed and sanitized for subsequent use.

Figure 8 discloses another aspect of the present invention. The flow control device 10 illustrated in Figure 8 includes a tubular member 14 with an opening passing through the entirety of the side wall 108 to allow the diameter of the tubular member 14 to be adjusted to a larger or smaller opening diameter at the inner end 16 and/or outer end 18. Opposing sides 110 and 112 of the side wall 108 include a column of eyelets 116 proximate side 110 and a plurality of adjustment points 106 comprising a plurality of eyelets 116 generally adjacent the opposing side 112. The eyelets 116 and adjustment points 106 on opposing sides 110 and 112 of the side wall 108 are configured generally horizontal relative to each other. A plurality of tethers 114, such as surgical suture, pass through the eyelets 116 and adjustment points 106 to drawn the opposing sides 110 and 112 of the side wall 108 together depending upon the desired size of the opening for the inner end 16 of tubular member 14. Adjustment points 106 allow the diameter of the tubular member 14 to be increased or decreased accordingly. The interior side wall 22 of the tubular member 14 includes a balloon valve 20, as previously discussed, in communication with a passageway terminating externally in a check valve 118. In use, the inner end 16 of the flow control device 10 is surgically attached about a body opening, such as the rectum of the person. Depending upon the size of the rectum of the individual, proper adjustments are made to the diameter of the inner end 16 of tubular member 14 to encircle the rectum with the inner end 16 of the flow control device 10. Tethers 114 are adjusted to size the tubular member 14 accordingly. Inflation and deflation of the balloon valve 20 provides obstruction to and passage of matter and fluids passing from the rectum.

The invention has been shown and described above with the preferred embodiments, and it is understood that many modifications, substitutions, and additions may be made which are within the intended spirit and scope of the invention. From the foregoing, it can be seen that the present invention accomplishes at least all of its stated
5 objectives.

What is claimed is:

1. A flow control and collection system for human excretions comprising:
a flow control device comprising:
 - 5 a) a tubular member having inner and outer ends interconnected by a passageway and adapted for insertion into a body opening;
 - b) a device adapter at the outer end of the tubular member having one or more interlocking features;a collection bag comprising:
 - 10 a) a sealed body having at least one opening;
 - b) a bag adapter at the opening having one or more counterpoising interlocking features to removably lock the adapters together.
- 15 2. The system of claim 1 wherein the flow control device further comprises an inflatable balloon valve attached within the passageway for selectively allowing passage of matter and/or fluids.
3. The system of claim 1 wherein the flow control device further comprises an
20 expandable membrane on the outside of the inner end of the tubular member for selectively securing the control device in the body opening.
4. The system of claim 3 wherein the expandable membrane further comprises a wire
25 frame having a collapsed position for inserting the inner end of the tubular member into the body opening and a pre-collapsed position for supporting the tubular member when the expandable membrane is inflated.
5. The system of claim 1 wherein the device adapter comprises an inner surface
30 adjacent the outer end of the tubular member having a concave shape to prevent compression of tissue around the body opening.

6. The system of claim 1 wherein the interlocking features comprise a plurality of radially spaced keyways and the counterpoising interlocking features comprise a plurality of radially spaced keys.

5 7. The system of claim 1 wherein the interlocking features comprise a plurality of radially spaced female contacts and the counterpoising interlocking features comprise a plurality of radially spaced male contacts.

8. The system of claim 1 wherein the flow control device further comprises a cap
10 having a plurality of radially spaced counterpoising interlocking features to removably lock the cap to the adapter.

9. The system of claim 1 wherein the collection bag further comprises a cap having a
15 plurality of radially spaced interlocking features to removably lock the cap to the bag adapter.

10. A flow control device for human excretions comprising:
a tubular member having inner and outer ends interconnected by a passageway and the
inner end adapted for insertion into a body opening;
20 a device adapter at the outer end of the tubular member; and
a plurality of radially spaced interlocking features formed in the device adapter.

11. The device of claim 10 wherein the interlocking features comprise a plurality of
25 radially spaced keyways.

12. The device of claim 10 further comprising a wire frame supported inflatable
membrane outside on the inner end of the tubular member, the membrane and wire frame
moveable between collapsed and pre-collapsed positions for inserting the inner end of the
device in the collapsed position.
30

13. The device of claim 10 further comprising a cap having a plurality of radially spaced counterpoising interlocking features to removably lock the cap to the device adapter.

5 14. The device of claim 10 in combination with a collection bag comprising an opening with a bag adapter having a plurality of radially spaced counterpoising interlocking features to removably lock the adapters together.

15. The device of claim 10 in combination with a bagless device having:

- 10 a) an adapter with a plurality of radially spaced counterpoising interlocking features to removably lock the adapters together; and
b) a tube extending from the adapter and having a generally accurate shape.

15 16. The device of claim 15 further comprising a degradable tubular sleeve having an inlet adapted for removable attachment to the tube to carry matter and/or fluids away from the body opening.

17. A bag for collecting human excretions comprising:
a sealed body having at least one opening;

20 a bag adapter attached to the body around the opening, the bag adapter comprising:

- a) a generally planar surface;
b) a plurality of radially spaced interlocking features; and
c) the interlocking features for removably locking the bag to an outer end of a device adapted for insertion into a body opening.

25

18. The bag of claim 17 wherein the interlocking features comprise keys having twist to lock and twist to unlock positions.

30 19. The bag of claim 17 further comprising a cap having a plurality of radially spaced counterpoising interlocking features to removably lock the cap to the bag adapter.

20. The bag of claim 19 wherein the counterpoising interlocking features comprise keyways to removably lock the cap to the bag adapter.

21. The bag of claim 17 in combination with a flow control device comprising a tubular member having inner and outer ends interconnected by a passageway and a device adapter at the outer end of the tubular member having a plurality of radially spaced counterpoising interlocking features.

22. The bag of claim 21 wherein the counterpoising interlocking features comprise keyways having a locked and unlocked position on the bag adapter.

23. A flow control device for human excretions comprising:
a tubular member having inner and outer ends interconnected by a passageway, the tubular member having a discontinuous sidewall, and the inner end adapted for surgical attachment at a body opening;
a plurality of tube diameter adjustment points spaced opposite one another on opposing sides of the discontinuity in the sidewall; and
a tether between opposing adjustment points to adjust the diameter of the passageway to the size of the body opening.

20

24. The device of claim 23 further comprising an inflatable balloon valve attached within the passageway for selectively allowing passage of matter and/or fluids.

25. The device of claim 23 wherein the body opening comprises a human rectum and the tether provides adjustment of the diameter of the passageway for varying size rectums so as to encircle the rectal area.

1/8

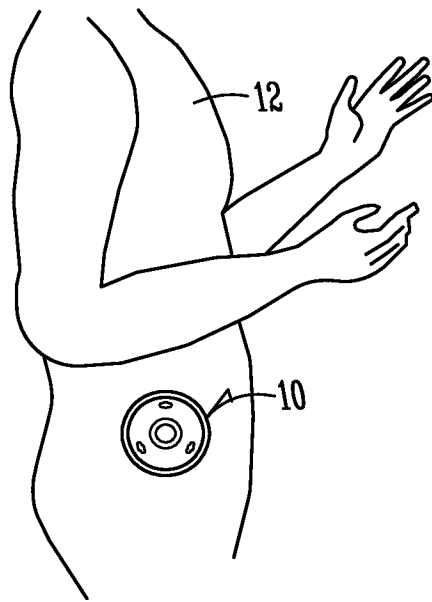

Fig. 1

2/8

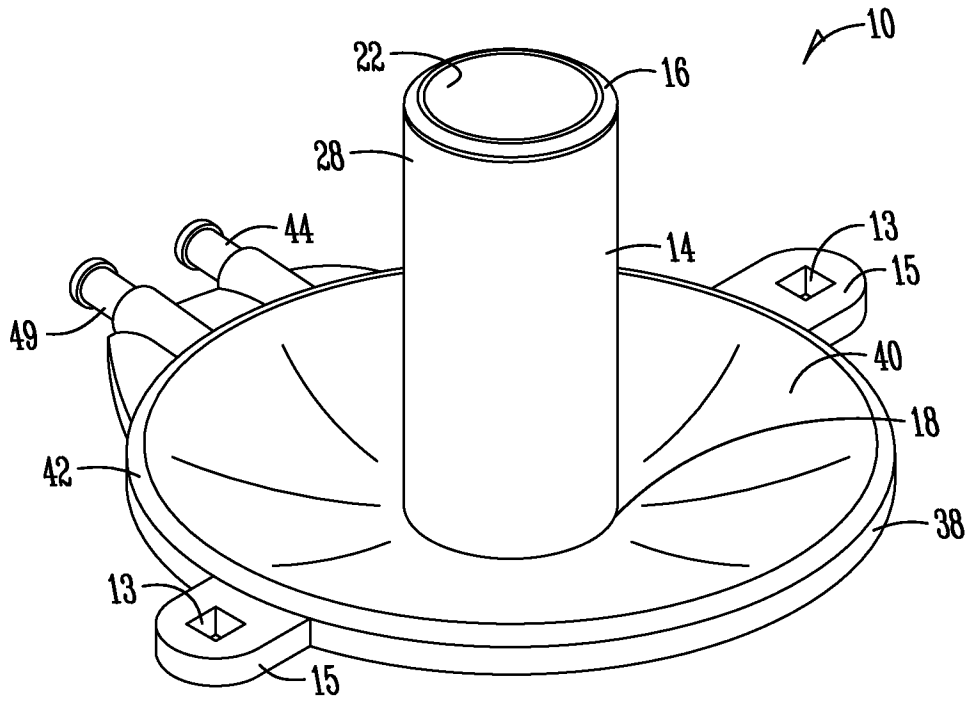

Fig. 2A

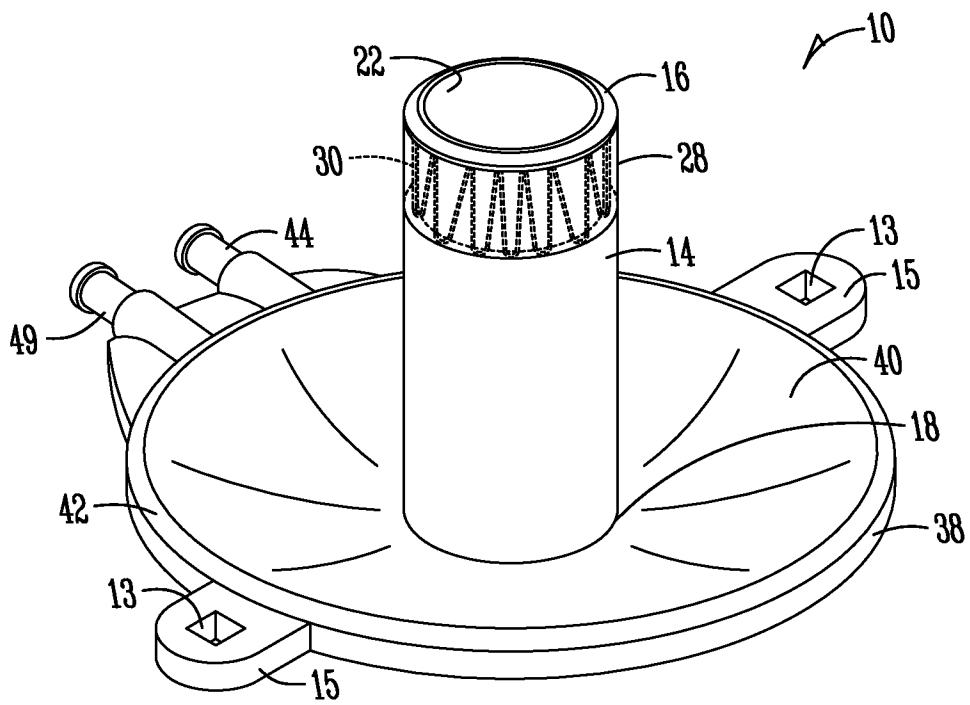

Fig. 2B

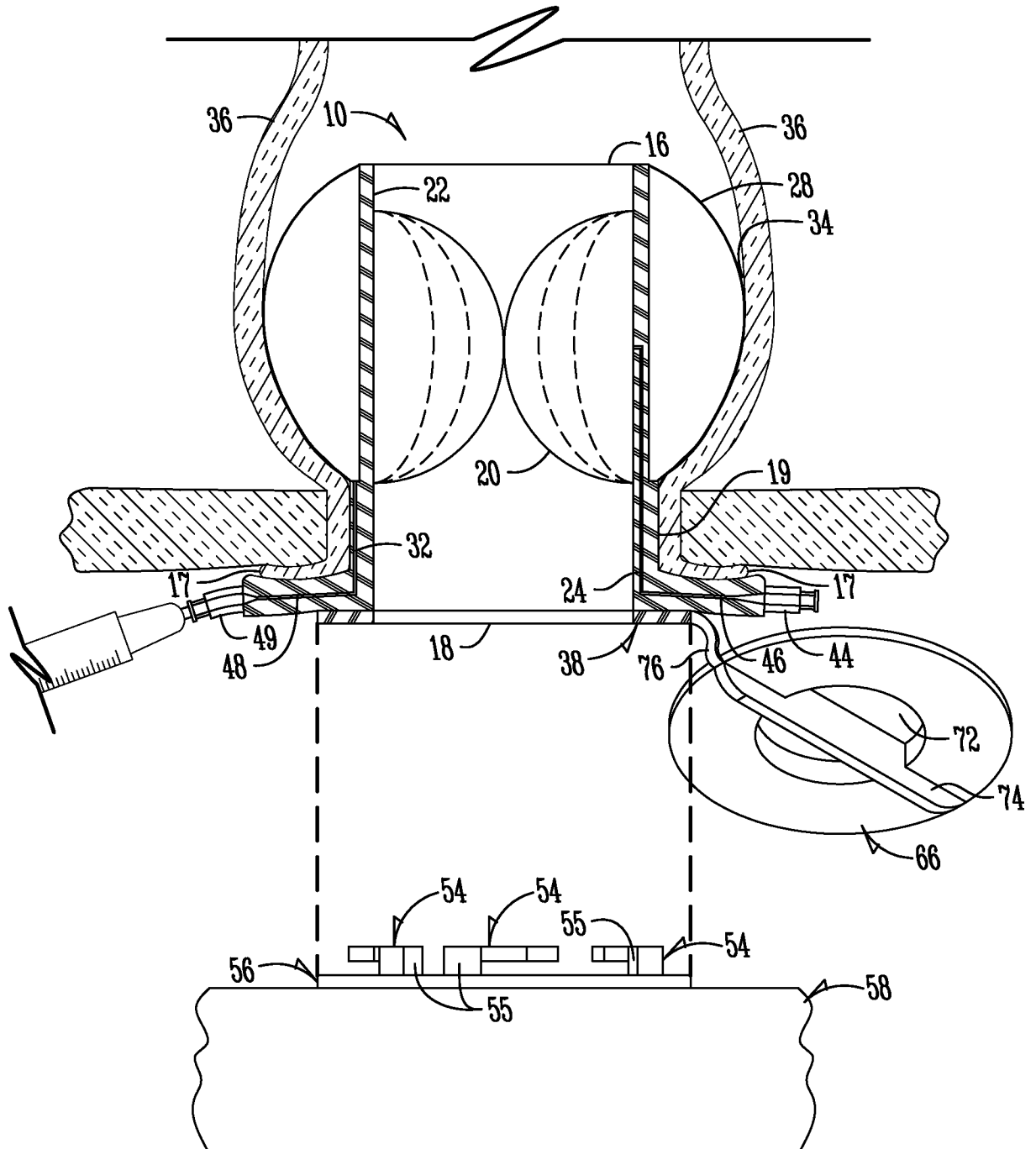

Fig. 3

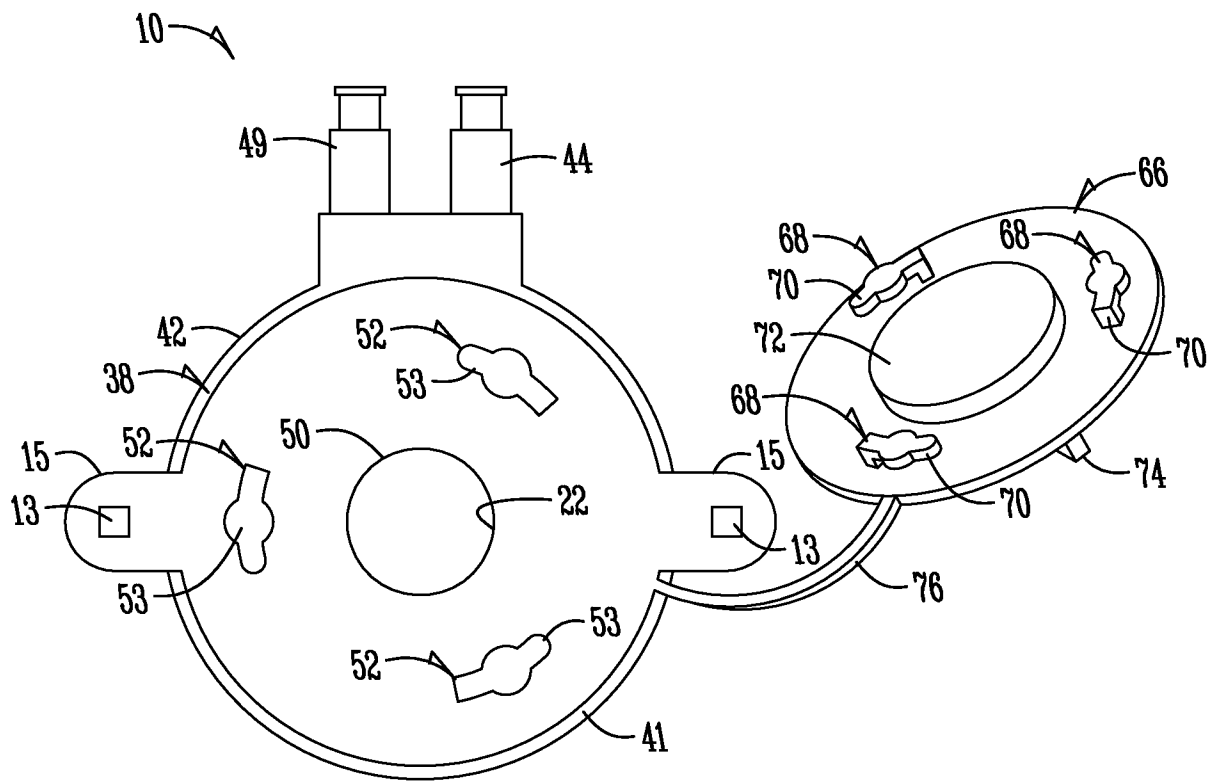

Fig. 4

5/8

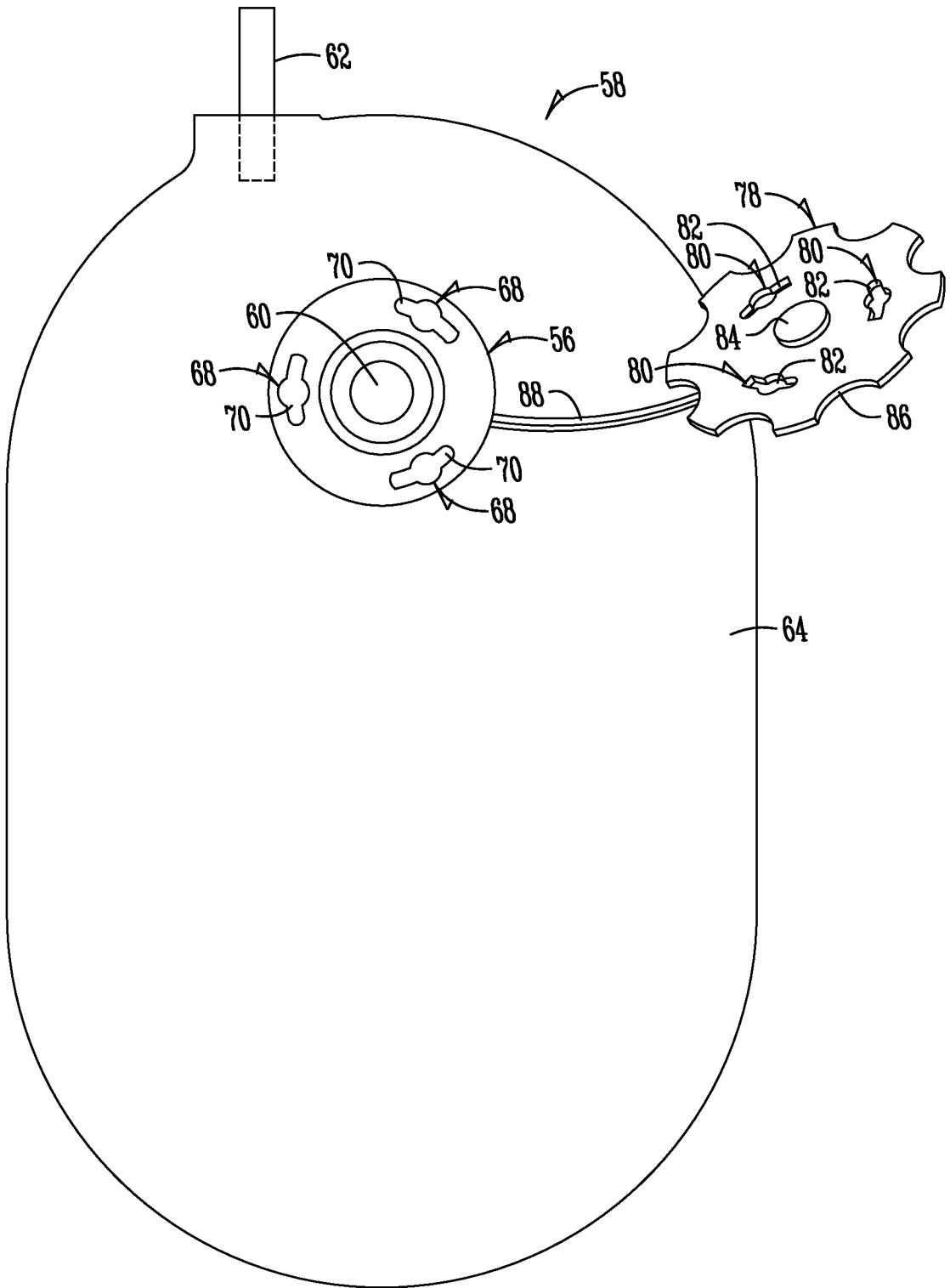

Fig. 5

6/8

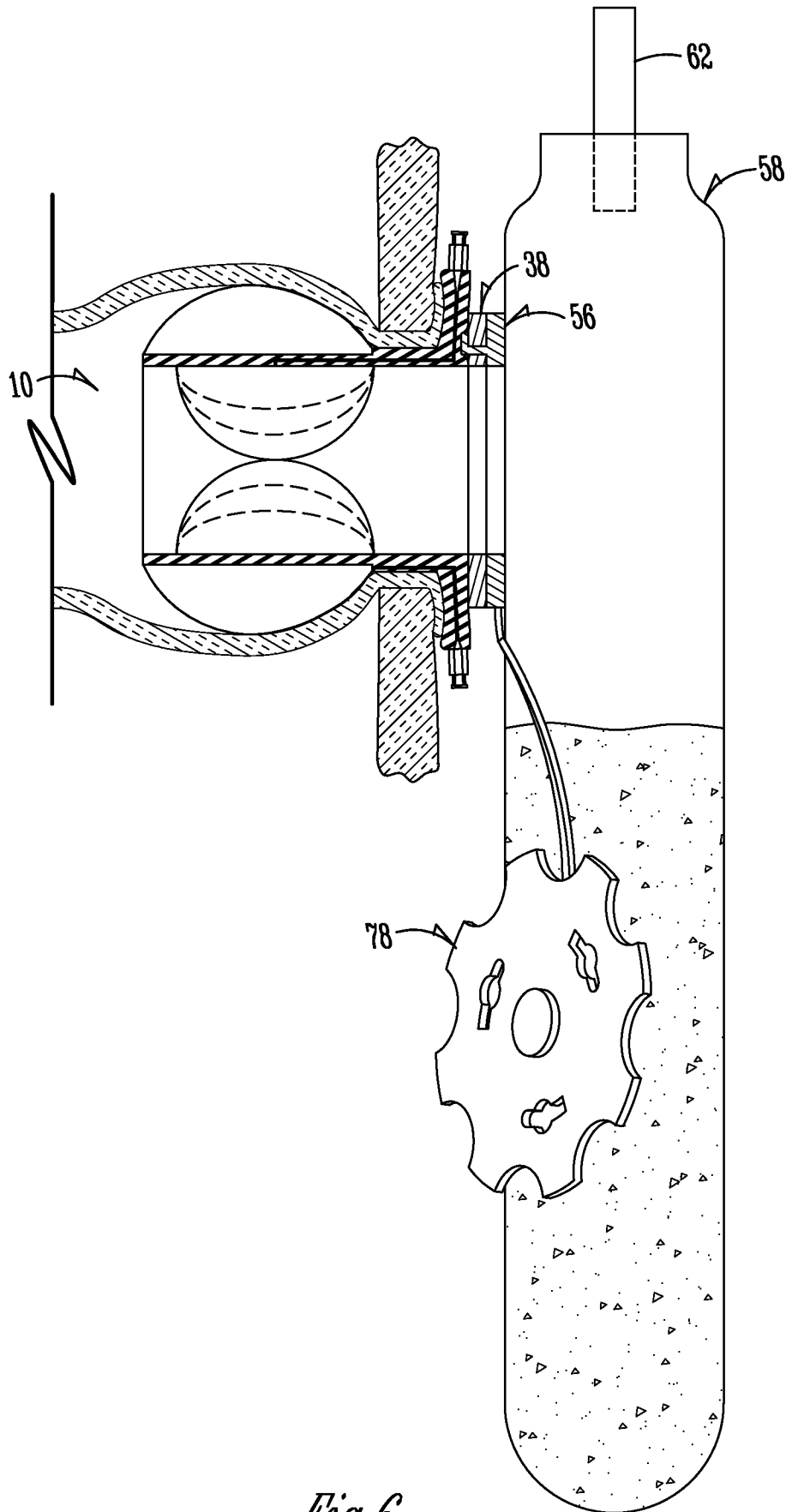

Fig. 6

7/8

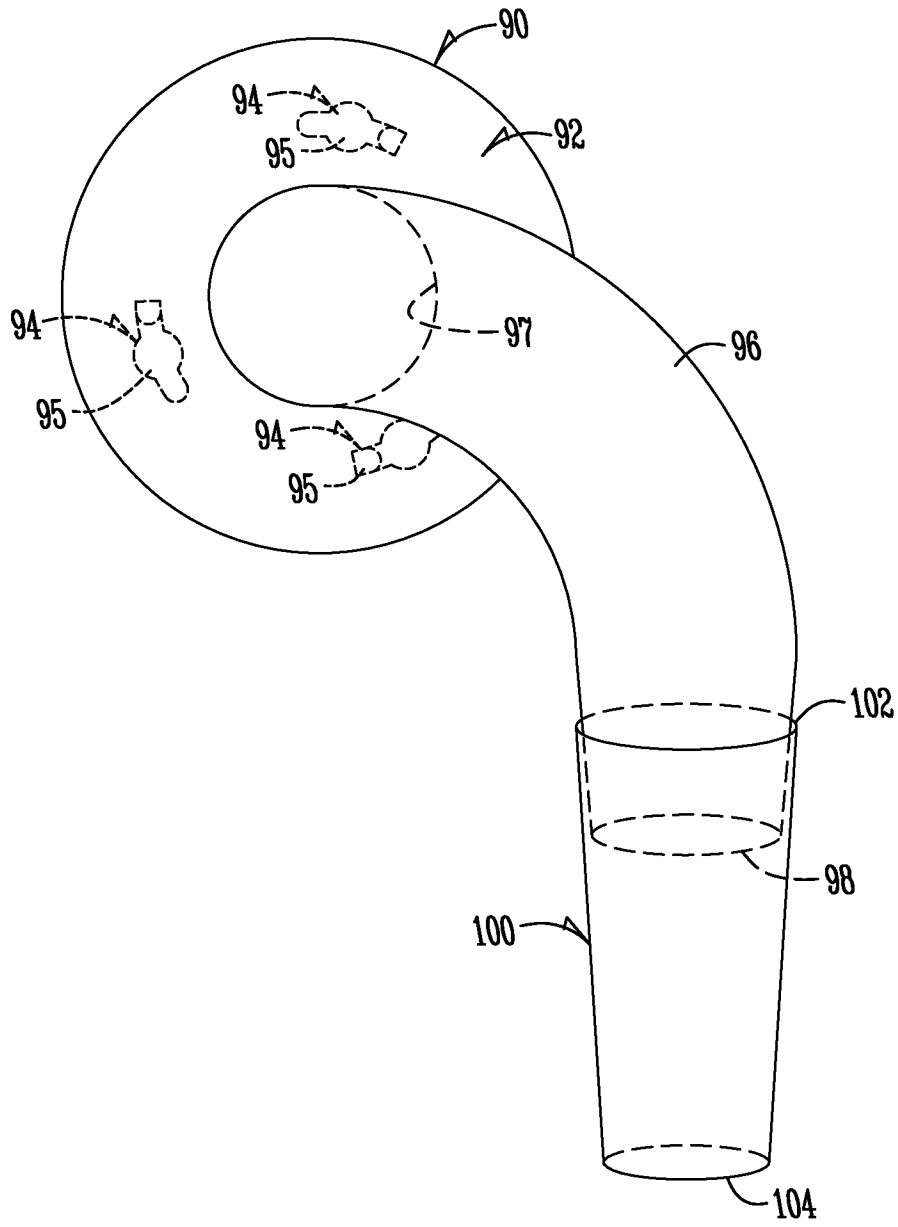

Fig. 7

8/8

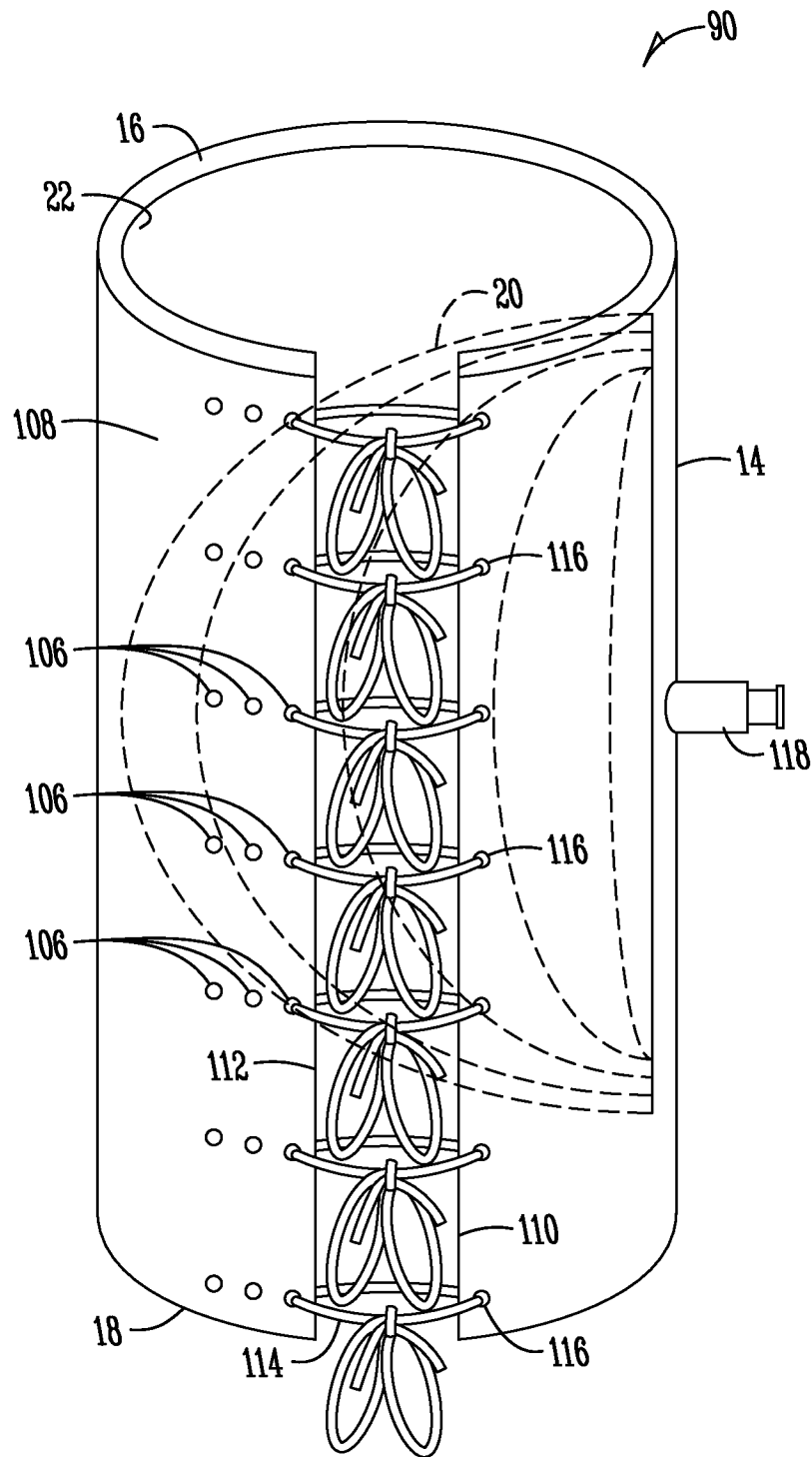

Fig. 8