

(19) World Intellectual Property Organization  
International Bureau



(43) International Publication Date  
15 March 2001 (15.03.2001)

PCT

(10) International Publication Number  
**WO 01/17845 A1**

- (51) International Patent Classification<sup>7</sup>: **B62J 11/00** (74) Agent: **MAROSCIA, Antonio**; Maroscia & Associati S.R.L., Corso Palladio, 42, I-36100 Vicenza (IT).
- (21) International Application Number: PCT/IB00/01197 (81) Designated States (*national*): CA, JP, US.
- (22) International Filing Date: 29 August 2000 (29.08.2000) (84) Designated States (*regional*): European patent (AT, BE, CH, CY, DE, DK, ES, FI, FR, GB, GR, IE, IT, LU, MC, NL, PT, SE).
- (25) Filing Language: English
- (26) Publication Language: English
- (30) Priority Data: VI99U000073 3 September 1999 (03.09.1999) IT  
Published:  
— With international search report.
- (71) Applicant (*for all designated States except US*): **ELITE SRL** [IT/IT]; Via Fornaci, 4, I-35014 Fontaniva (IT).  
*For two-letter codes and other abbreviations, refer to the "Guidance Notes on Codes and Abbreviations" appearing at the beginning of each regular issue of the PCT Gazette.*
- (72) Inventor; and  
(75) Inventor/Applicant (*for US only*): **SARTORE, Almerigo** [IT/IT]; Via Velo, 47, I-35014 Fontaniva (IT).

(54) Title: SUPPORT STRUCTURE FOR BICYCLE BOTTLES AND SIMILAR CONTAINERS

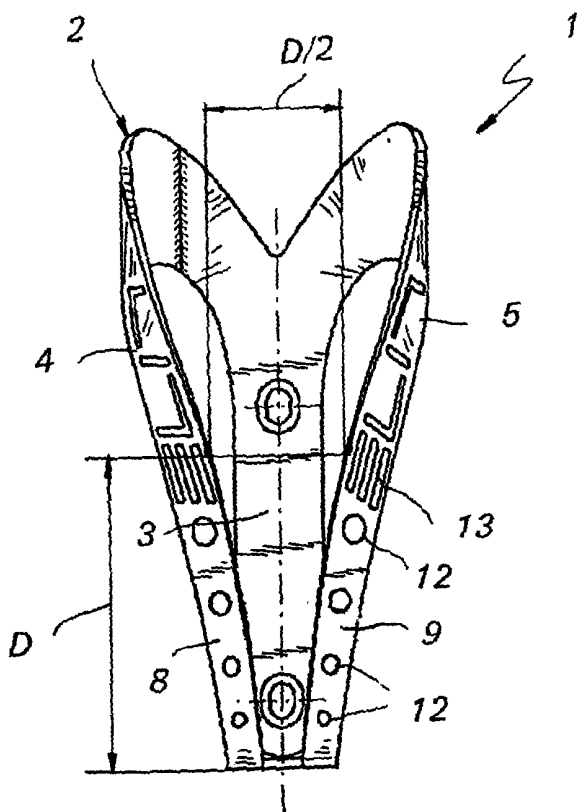

(57) Abstract: A support structure for bicycle bottles, or similar containers comprises a cage-like or three-dimensional supporting frame (2) and anchoring means (6, 7) for securing to a bicycle frame or to a similar member. The supporting structure (2) comprises a rear post (3) with two arms (4, 5) extending from its upper end, said arms being substantially symmetrical and diverging from each other. The arms (4, 5) are at least partially bent upwardly, forwardly and downwardly in order to embrace the lateral wall of a bottle (B), the lower end portions (8, 9) of the arms converge and are connected to each other to form a lower appendix (10) directed towards the post (3) that is suitable to support the bottom wall of the bottle (B). The arms (4, 5) and the post (3) are positioned over a substantially cylindrical surface whose inner diameter (D) is slightly larger than the outer diameter ( $\emptyset$ ) of the bottle (B). The maximum span (d) between the inner edges of the converging lower ends (8, 9) of the arms is smaller than or equal to the half of the inner diameter (D) at a distance (h) from the appendix (10) that is substantially equal to the inner diameter (D). The support structure exhibits a reduced weight, an improved drag efficiency, a larger file of the bicycle bottle. INV10501



WO 01/17845 A1

## SUPPORT STRUCTURE FOR BICYCLE BOTTLES AND SIMILAR CONTAINERS

Field of the invention

5 The present invention relates to a support structure for bicycle bottles suitable for practising sports and leisure, or for similar containers, of the type comprising a cage-like or three dimensional supporting frame, as well as anchoring means for attaching to a bicycle frame or to a similar member.

10

Background of the invention

Supports of the above mentioned type are known in the art, wherein the supporting frame is formed by a wire wound and bent in different ways, and so shaped as to house a bicycle bottle. An example of said known conventional supports is disclosed in the Italian application for utility model application 15 No. VI93U000020 filed by the same applicant.

Several drawbacks and shortcomings of said known types of supports are to be found in their excessive cost and weight, in their limited gripping action on the 20 bottle, in their remarkable cross sectional encumbrance and in their insufficient aerodynamic efficiency.

Summary of the invention

25 The support structure according to the present invention aims at overcoming the above mentioned drawbacks, by providing a support structure for bicycle bottles and similar containers that features a remarkable cost-effectiveness, enhanced mechanical gripping action on the bottle, and further a reduced encumbrance and a suitably enhanced aerodynamic efficiency.

30

The above aim is accomplished by a support of the above outlined type which, according to claim 1, is characterised in that said supporting frame comprises a rear anchoring post with an upper end, two arms extending from the upper end and being substantially symmetrical and diverging from each other, said arms  
5 further being at least partially bent upwardly, forwardly, and downwardly so as to embrace the lateral wall of a bicycle bottle, the lower ends of said arms converging and being reciprocally joined so as to form a lower appendix directed towards said post, said appendix being suitable for supporting the bottom wall of said bicycle bottle.

10

Advantageously the arms and the post of said supporting frame are located over a substantially cylindrical surface having an inner diameter that is slightly larger than that of the bicycle bottle or container to be supported.

15 A main feature of the present invention is that the minimum distance between the inner edges of the lower converging ends of said arms is substantially equal or smaller than the half of said inner diameter at a distance from said appendix that is equal or smaller than said inner diameter. Thanks to this relationship, the supporting structure guarantees an excellent gripping action on the bicycle  
20 bottle even in heavy situations.

Advantageously, the inner diameter of the cylindrical surface is sized so as to be capable of supporting cycling bottles having a diameter that is shorter than the standard lengths, so as to reduce the encumbering width of the supporting  
25 frame and to increase its aerodynamic efficiency.

#### Brief description of the drawings

Further features and advantages will be more apparent from the detailed  
30 description of several preferred embodiments of the support structure according

to the present invention, illustrated by way of not limiting examples with reference to the annexed tables of drawings, wherein:

Fig. 1 represents a front view of a first embodiment of the support structure without gripping means for a bottle;

5 Fig. 2 represents a lateral view of the support structure of Fig. 1, sectioned along a diametral vertical plane;

Fig. 3 is a plan view from above of the support structure of Fig. 1;

Fig. 4 is a front view of a second embodiment of support structure according to the present invention;

10 Fig. 5 is a lateral view of the support structure of Fig. 4, sectioned along a diametral sectional plane;

Fig. 6 is a plan view from above of the support structure of Fig. 4;

Fig. 7 is a sectional view in greater scale of a detail of Fig. 4;

15 Fig. 8 is a front view of a third embodiment of support structure according to the present invention;

Fig. 9 is a lateral view of the support structure of Fig. 8 sectioned along a diametral vertical plane;

Fig. 10 is a plan view from above of the support structure of Fig. 8;

Fig. 11 is a sectional view in greater scale of a detail of Fig. 8;

20 Fig. 12 is a front view of a fourth embodiment of support structure according to the present invention;

Fig. 13 is a lateral view of the support structure of Fig. 12, sectioned along a vertical diametral plane;

Fig. 14 is a plan view from above of the support structure of Fig. 12;

25 Fig. 15 is a sectional view in greater scale of a detail of Fig. 14;

Fig. 16 is a front view of a fifth support structure according to the present invention;

Fig. 17 is a lateral view of the support structure of Fig. 16;

30 Fig. 18 is a lateral view of the support of Fig. 16 sectioned along a vertical diametral plane;

Fig. 19 is a general perspective view of a support structure for bicycle bottles of the present invention in its operating condition.

Description of a preferred form of embodiment

5

With reference to the figures, a support structure for bicycle bottles and similar containers, overall indicated with the reference numeral 1, comprises a supporting frame 2 made of a relatively rigid material, suitable to house and removably hold internally thereof a bottle B schematically depicted in Fig. 19  
10 with dotted lines.

According to the invention, the supporting frame 2 essentially comprises a back anchoring post 3 extending along a longitudinal axis L, with two supporting arms 4, 5 extending from the upper end of post 3.

15

Preferably, post 3 has a substantially "C" shaped section and is provided with means for anchoring to a bicycle frame or a similar member. In this particular case, said anchoring means consist of two holes 6 formed in corresponding recesses 7 for screw heads.

20

Arms 4, 5 are symmetrical and diverging from the longitudinal axis L, and they are bent along a curved space line first upwardly, then forwardly and eventually downwardly in order to embrace the lateral wall of bottle B.

25 Suitably, the lower ends 8, 9 of arms 4,5 converge and are reciprocally joined so as to form a substantially "V" or "U" shaped lower appendix 10 directed towards post 3 and adapted to support the bottom wall of bottle B.

Suitably, the post 3 and the arms 4, 5 are located along a substantially  
30 cylindrical surface having an inner diameter D that is slightly larger than

diameter  $\emptyset$  of bottle B.

The lower ends 8, 9 of arms 4, 5 are formed so as to be capable of holding bottle B in a stable and reliable manner in every operating conditions, thereby  
5 avoiding any accidental removal thereof from the space between the inside edges of arms 4, 5.

To this end, at a predetermined distance  $h$  from appendix 10, the span  $d$  between the inside edges of lower converging edges 8, 9 of arms 4, 5 has a  
10 predetermined maximum value.

In particular, at a distance  $h$  which equals to the value  $D$  of the inner diameter of the supporting frame 2, the span  $d$  is smaller than or equal to the value of said inner diameter  $D$ .

15

Such a condition may be summarised as follows:

$$\text{for } h = D \Rightarrow d = D/2$$

Preferably, the width of arms 4, 5 in correspondence of their curved upper areas  
20 is slightly smaller than half the length of the inner diameter, more specifically it is approximately equal to  $D/2.2$ .

The inner diameter  $D$  is sized so as to house bottles having an outer diameter  $\emptyset$  smaller than their standard sizes, so as to reduce the encumbering width of the supporting frame, thus remarkably reducing the transversal encumbrance and  
25 the aerodynamic drag, and optimising the aerodynamic efficiency of the bottle support. By way of example, the diameter  $D$  may range between 40 mm. and 50 mm., and may preferably be 45 mm long.

30 Preferably, the post 3 and the arms 4, 5 are unitarily formed and have a plate

configuration with a plane cross-section so as to define a supporting frame 2 of a continuous and monolithic type, that can be obtained by moulding or injection moulding.

- 5 For example, monolithic structure 2 may be produced starting from a metal plate or from a multi-sandwich type plastic sheet.

The supporting structure 2 may be provided with one or more lightening holes 11, 12 or with slits shaped as a writing or a symbol positioned peripherally of  
10 the frame and along arms 4, 5.

In general, the supporting structure 2 may be provided with the bottle gripping means located along arms 4, 5.

- 15 In the embodiment shown in Figs. 1 to 3, no gripping means are provided, because such function is uniquely exerted by the plastic material forming the supporting frame 2.

The embodiment shown in Figures 4 to 7 differs from the previous one only in  
20 that the gripping means consist of a centrally located pad 14 formed by an ellipsoidal shaped plate 15 made of a relatively rigid material that is anchored to portions 8, 9 of arms 4, 5, the pad 14 centrally supports a ball 16 resiliently held by a boss 17 made of a resiliently flexible material, rubber or plastics for example. Thus, bottle B will be resiliently clamped by the ball 16 against the  
25 elastic biasing action of boss 17.

The embodiment shown in Figures 8 to 11 differs from the previous one only in that the gripping means consist of a resilient pad 18 made of a boss 19 of resiliently flexible material, held by an ellipsoidally shaped connecting plate 20.

The resiliently flexible material forming the boss may be chosen among the group including gels, rubbers or plastic materials.

The embodiment shown in Fig. 12 to 15 differs from the previous one only in  
5 that the gripping means for the bottle B consist of a pair of substantially identical supports 21, each formed by a metal or plastic shell 22 which can be inserted into corresponding seats of portions 8, 9 of arms 4, 5, each shell housing internally thereof a pad 23 made of gel, rubber or formed by a small air chamber.

10

The embodiment shown in Fig. 16 to 18 differs from the previous ones essentially in that the gripping means for bottle B consist of a series of small elliptical rubber or plastic pads 24 formed on post 3 and provided with one or more transverse chevron groves 25, permitting the downward insertion of the  
15 bottle into the support frame while preventing upward easy removal thereof. The gripping means further comprise two rubber or plastic lips 26 inserted on to the upper edges of arms 4, 5 to further increase the gripping action on bottle B.

According to the foregoing description, it is clear that the support accomplishes  
20 its aims and particularly entails reduced weight, limited encumbrance reduced aerodynamic drag, and higher reliability in terms of capability to firmly hold the bottle.

The instant application is based upon Italian patent application VI99U000073,  
25 filed on 3 September 1999, the disclosure of which is hereby expressly incorporated by reference thereto, and the priority of which is hereby claimed.



## CLAIMS

1. A support structure for bicycle bottles or similar containers (B), comprising a unitary supporting cage-like or three dimensional frame (2), anchoring means (6, 7) for securing to a bicycle frame or to a similar member, characterised in that said supporting frame (2) comprises a rear anchoring post (3) with an upper end from which two substantially symmetrical and diverging arms (4, 5) extend, said arms (4, 5) being at least partially bent upwardly, forwardly and downwardly so as to embrace the lateral wall of a bottle (B), the lower ends (8, 9) of said arms (4, 5) converging and being reciprocally joined so as to form a lower appendix (10) directed towards the post (3), and adapted to support the bottom wall of the bottle (B).
2. Support structure according to claim 1, characterised in that said arms (4, 5) and said post (3) are located along a substantially cylindrical surface having an inner diameter (D) that is slightly larger than the conventional diameter ( $\emptyset$ ) of the bottle (B) to be supported.
3. Support structure according to claim 2, characterised in that the inside edges of the lower converging ends (8, 9) of said arms house a maximum span ( $d$ ) that is smaller than or equal to the half of said inner diameter (D) at a distance ( $h$ ) from said appendix that is substantially equal to said inner diameter (D).
4. Support structure according to claim 2, characterised in that said inner diameter (D) has a predetermined side ranging between 40 mm and 50 mm and preferably equal to approximately 45 mm so as to be smaller than those of traditional bottles and to reduce the transversal

encumbrance of the supporting frame (2).

5. Support structure according to claim 1, characterised in that said arms (4, 5) and said post (3) are unitarily formed and in that they have a substantially plate configuration with plane cross-section so as to define a monolithic supporting frame.
6. Support structure according to claim 1, characterised in that said supporting frame (2) is formed starting from a metal plate or from a plastic sheet.
7. Support for bottle according to claim 1, characterised in that said supporting frame (2) is provided with one or more lightening holes (11, 12, 13) peripherally located along said arms.
8. Support structure according to claim 1, characterised in that said supporting frame (2) is provided with means for gripping the bottle located along said arms.
9. Support structure according to claim 8, characterised in that said gripping means comprise at least a resilient pad (17, 19, 23).
10. Support structure according to claim 1, characterised in that said gripping means comprise at least a planar element (15, 20, 22) made of a relatively rigid material that houses internally thereof a pad made of a resiliently flexible material.
11. Support structure according to claim 10, characterised in that said resiliently flexible pad comprises a rigid spherical member (16) held in place by a boss (17) made of a resiliently flexible material.

12. Support structure according to claim 10 or 11, characterised in that said resiliently flexible material is chosen in the group comprising gels, rubbers or plastic materials.
- 5 13. Support structure according to claim 1, characterised in that said ripping means comprises at least a pad (24) of rubber or plastic material located along said post (3).
- 10 14. Support structure according to claim 13, characterised in that each pad (24) has at least one transverse chevron groove (25) so shaped to permit downward insertion and preventing easy upward removal of a bottle within said support frame (2).
- 15 15. Support structure according to claim 13, characterised in that said gripping means further comprises at least one rubber or plastics lips (26) fitted onto the upper edges of said arms (4, 5) to further hold the bottle (B) upon location thereof into said supporting frame (2).

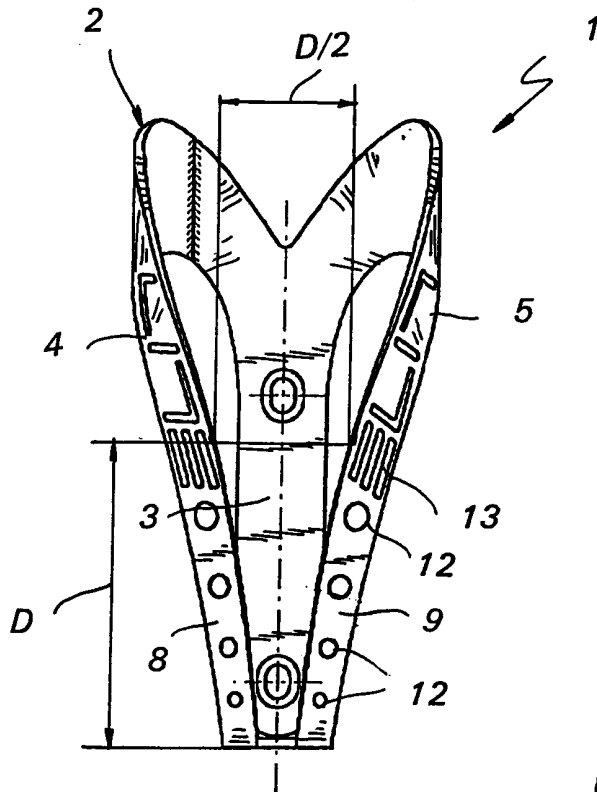

**Fig. 1**

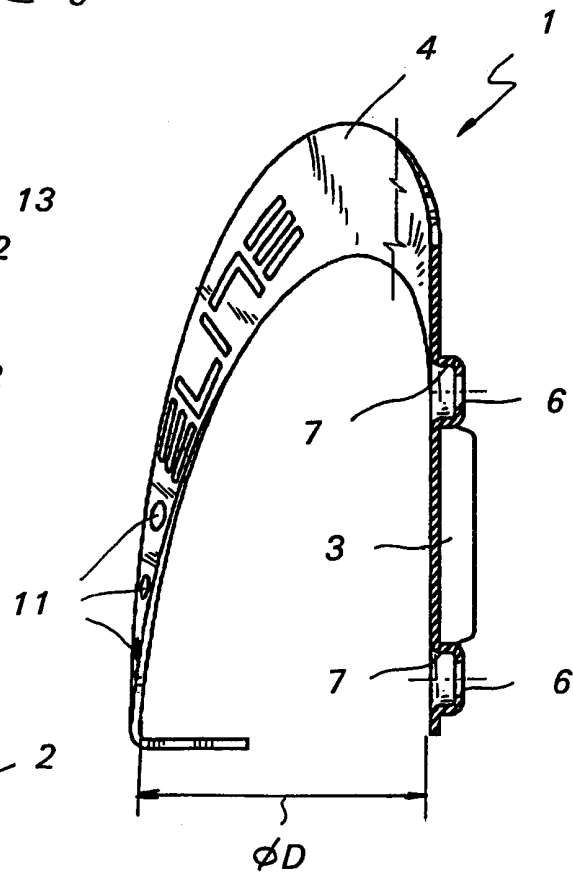

**Fig. 2**

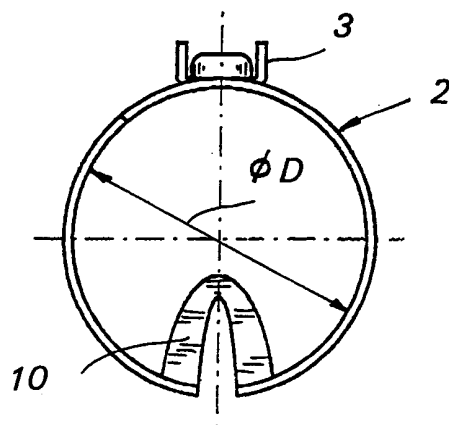

**Fig. 3**

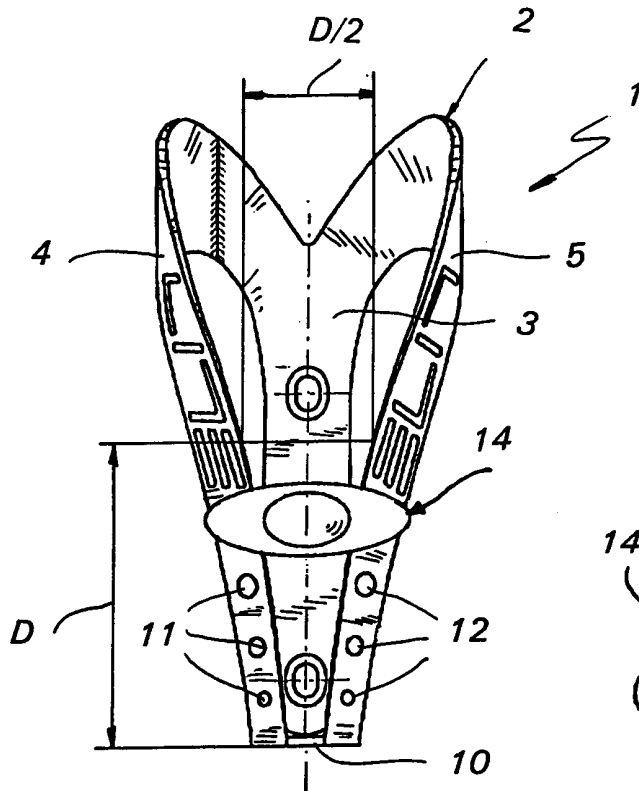

Fig. 4

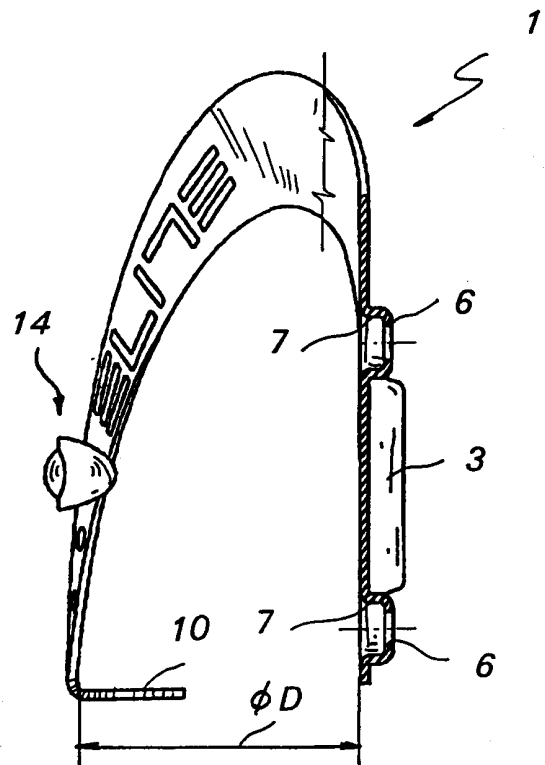

Fig. 5

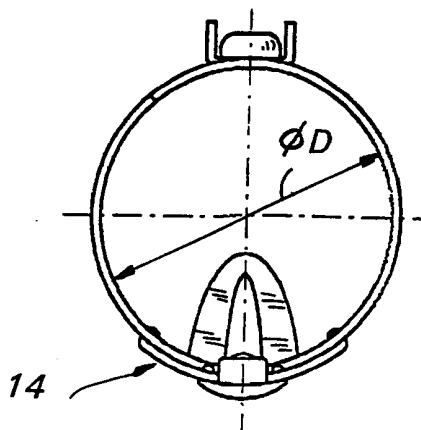

Fig. 6

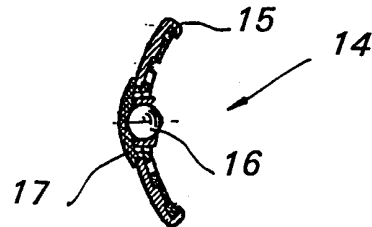
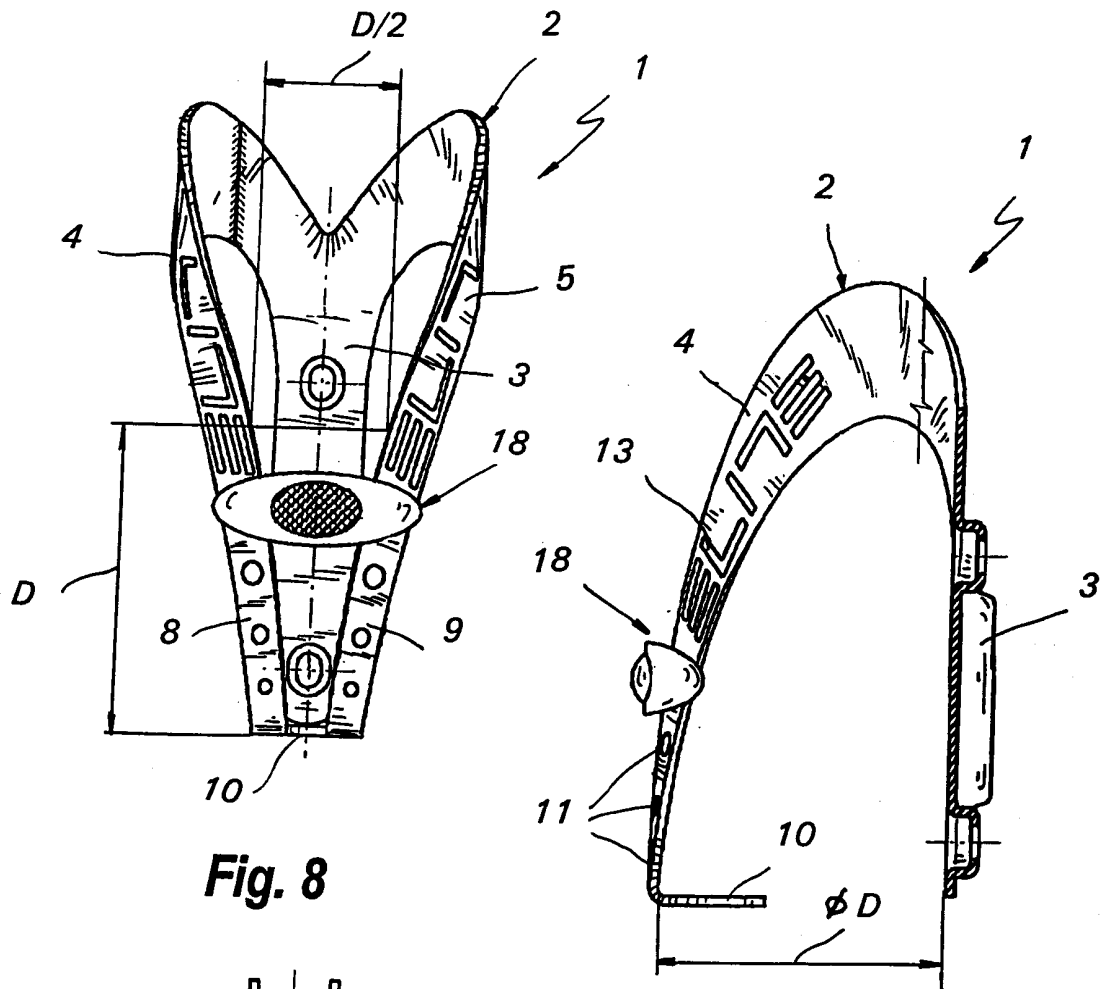
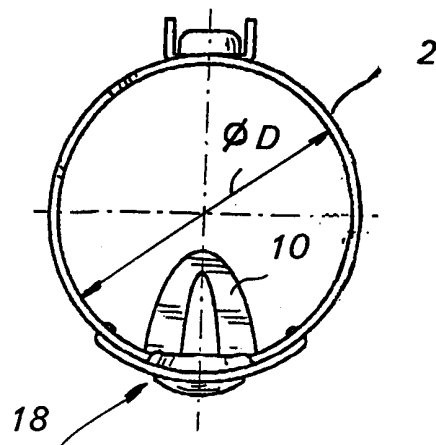

Fig. 7

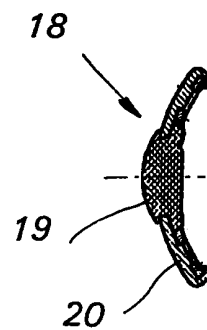

**Fig. 8**

**Fig. 9**



**Fig. 10**



**Fig. 11**

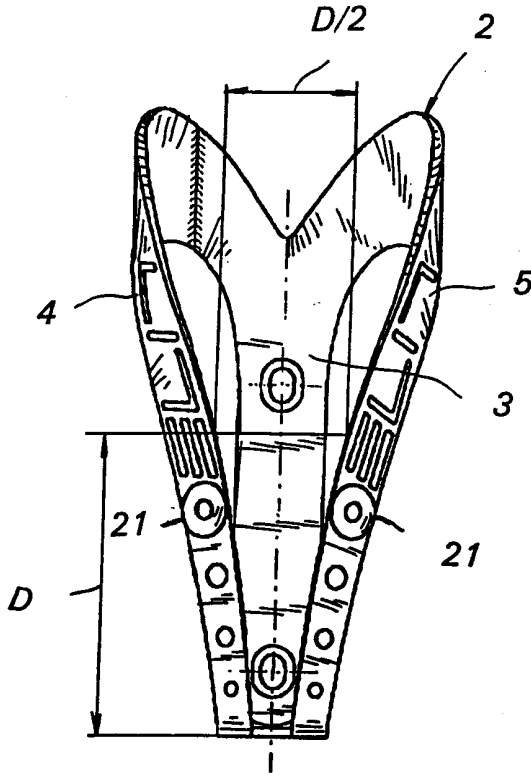

**Fig. 12**

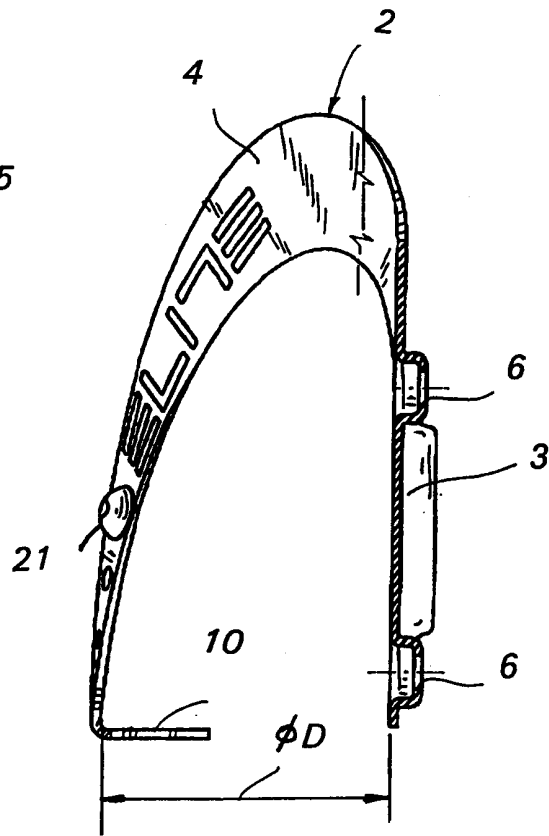

**Fig. 13**

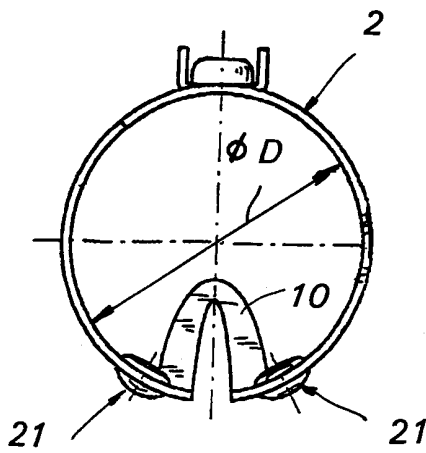

**Fig. 14**

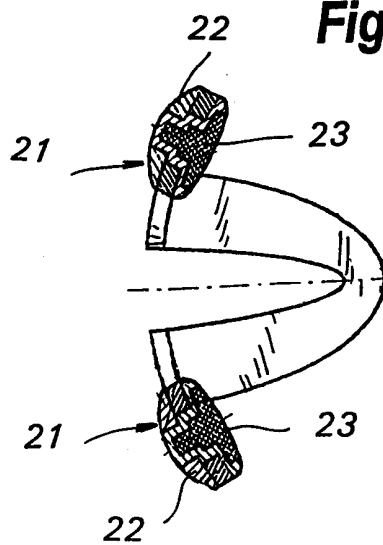

**Fig. 15**

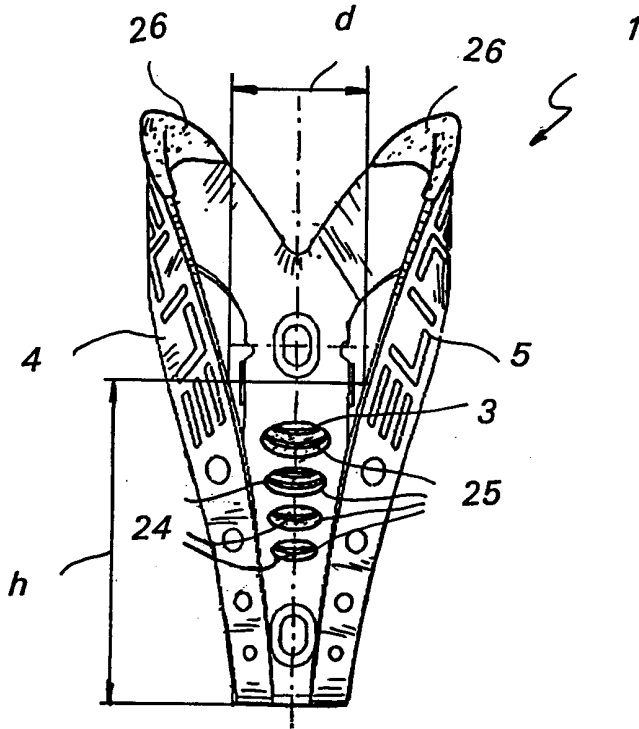

**Fig. 16**

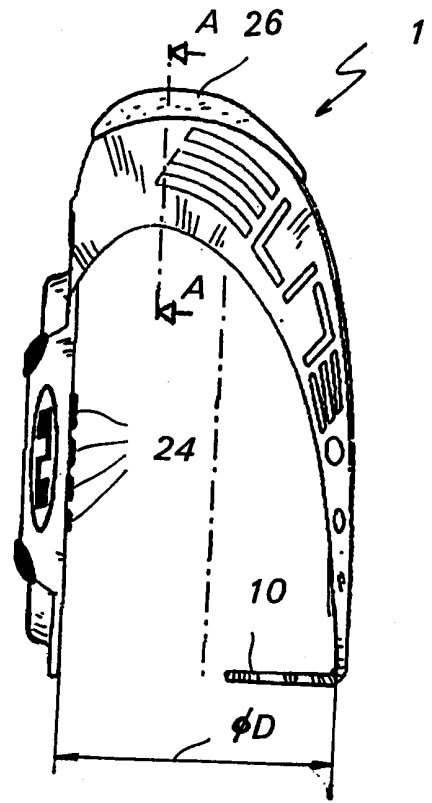

**Fig. 17**

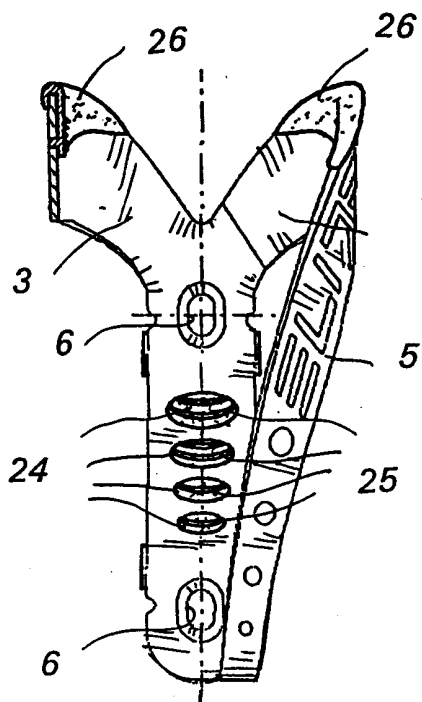

**Fig. 18**



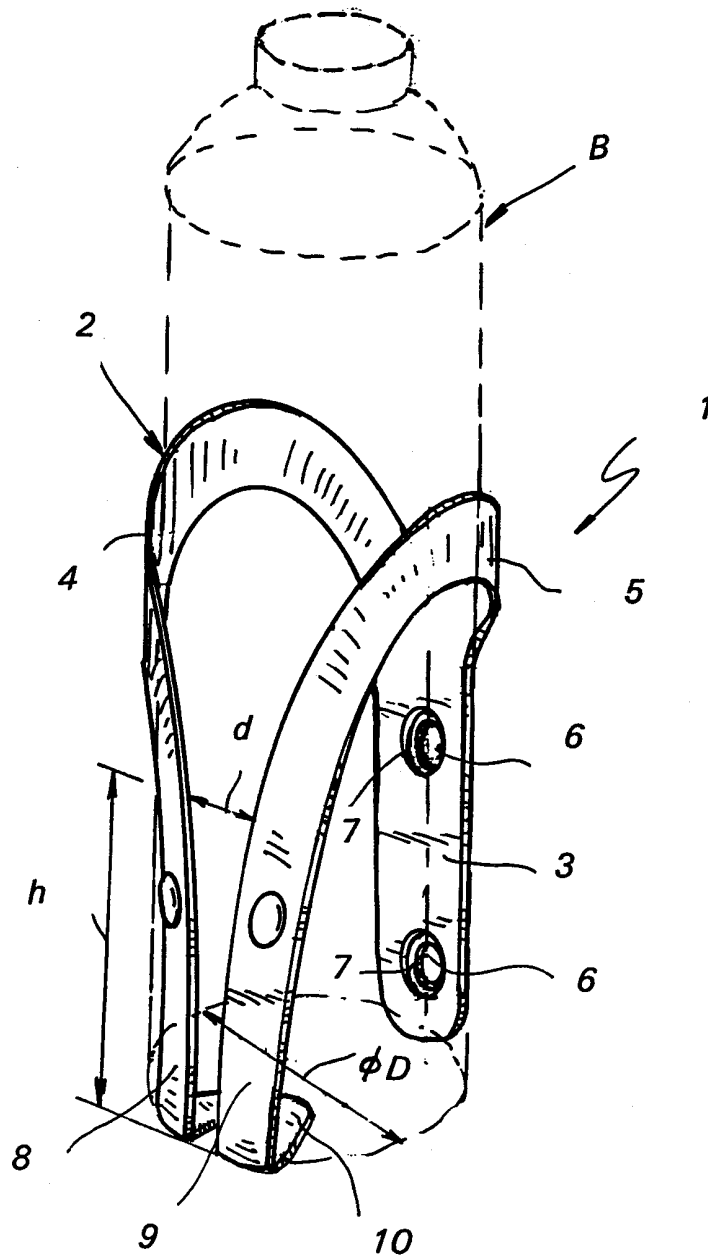

Fig. 19

# INTERNATIONAL SEARCH REPORT

International Application No

PCT/IB 00/01197

**A. CLASSIFICATION OF SUBJECT MATTER**

IPC 7 B62J11/00

According to International Patent Classification (IPC) or to both national classification and IPC

**B. FIELDS SEARCHED**

Minimum documentation searched (classification system followed by classification symbols)

IPC 7 B62J

Documentation searched other than minimum documentation to the extent that such documents are included in the fields searched

Electronic data base consulted during the international search (name of data base and, where practical, search terms used)

EPO-Internal, WPI Data, PAJ

**C. DOCUMENTS CONSIDERED TO BE RELEVANT**

Category °	Citation of document, with indication, where appropriate, of the relevant passages	Relevant to claim No.
X	EP 0 523 379 A (CANNONDALE CORP) 20 January 1993 (1993-01-20)	1-3, 5, 13
Y	column 3, line 18 -column 4, line 48; figures	7-9, 15
A		4, 6, 10, 14
Y	--- US 4 009 810 A (SHOOK WILLIAM BLAIR) 1 March 1977 (1977-03-01) column 1, line 46 -column 2, line 22; figures	8, 9, 15
Y	--- FR 2 615 158 A (GASPARD LOUIS) 18 November 1988 (1988-11-18) claims 1,10; figures -----	7

Further documents are listed in the continuation of box C.

Patent family members are listed in annex.

° Special categories of cited documents :

- \*A\* document defining the general state of the art which is not considered to be of particular relevance
- \*E\* earlier document but published on or after the international filing date
- \*L\* document which may throw doubts on priority claim(s) or which is cited to establish the publication date of another citation or other special reason (as specified)
- \*O\* document referring to an oral disclosure, use, exhibition or other means
- \*P\* document published prior to the international filing date but later than the priority date claimed

- \*T\* later document published after the international filing date or priority date and not in conflict with the application but cited to understand the principle or theory underlying the invention
- \*X\* document of particular relevance; the claimed invention cannot be considered novel or cannot be considered to involve an inventive step when the document is taken alone
- \*Y\* document of particular relevance; the claimed invention cannot be considered to involve an inventive step when the document is combined with one or more other such documents, such combination being obvious to a person skilled in the art.
- \*&\* document member of the same patent family

Date of the actual completion of the international search

1 December 2000

Date of mailing of the international search report

11/12/2000

Name and mailing address of the ISA

European Patent Office, P.B. 5818 Patentlaan 2  
NL - 2280 HV Rijswijk  
Tel. (+31-70) 340-2040, Tx. 31 651 epo nl,  
Fax: (+31-70) 340-3016

Authorized officer

Grunfeld, M

# INTERNATIONAL SEARCH REPORT

Information on patent family members

International Application No

PCT/IB 00/01197

Patent document cited in search report	Publication date	Patent family member(s)	Publication date
EP 0523379 A	20-01-1993	US 5145138 A JP 5305887 A	08-09-1992 19-11-1993
US 4009810 A	01-03-1977	NONE	
FR 2615158 A	18-11-1988	NONE	