

A. SCHWEITZER.
ELECTRIC ARC LAMP.

No. 522,233.

Patented July 3, 1894.

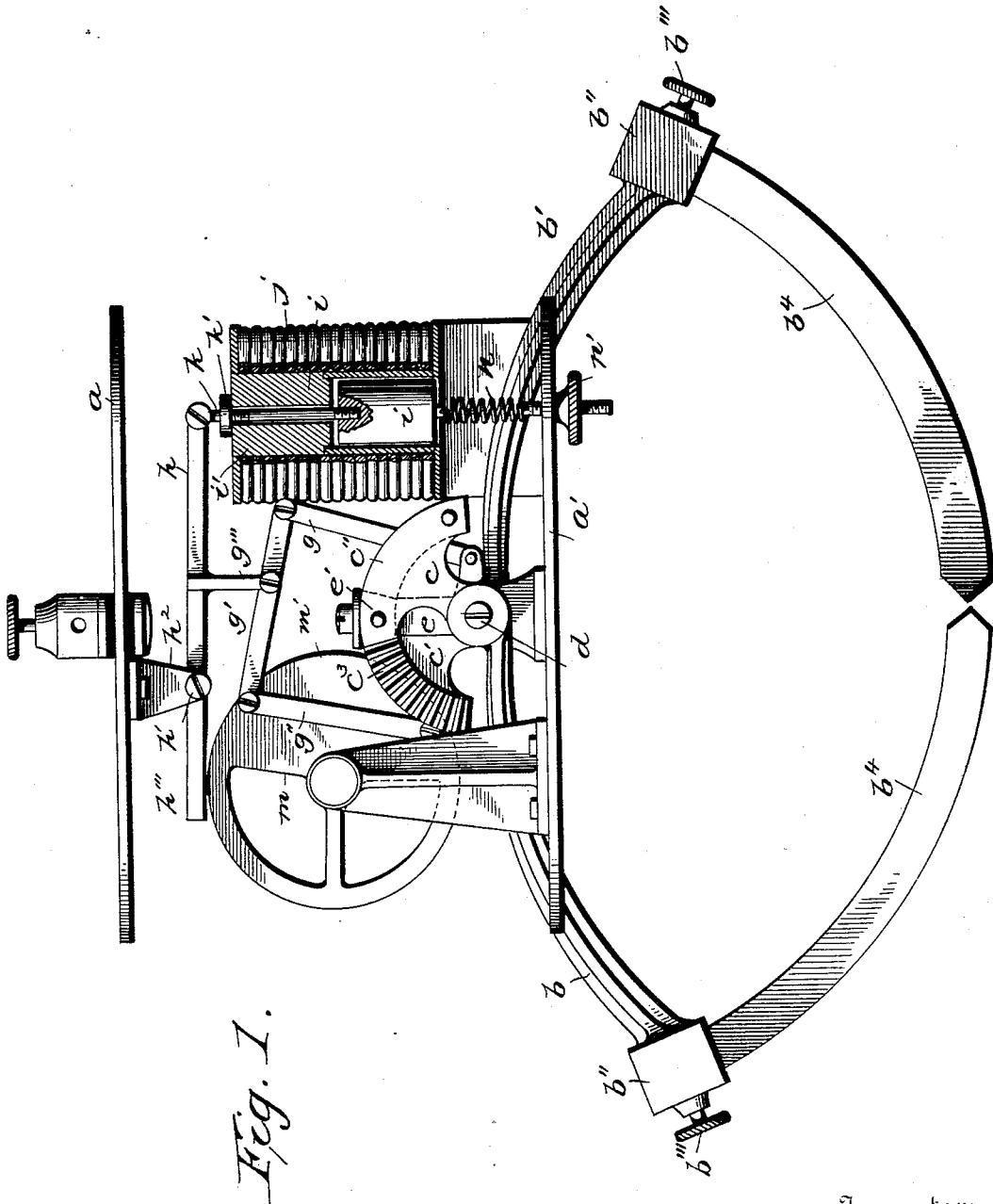

Fig. 1.

Witnesses
W. H. Audin
J. R. Owens

Inventor:
Albert Schweitzer
 By Attorneys
W. H. Audin

UNITED STATES PATENT OFFICE.

JOSEPH SACHS, OF NEW YORK, N. Y.

ELECTRIC SAFETY-FUSE.

SPECIFICATION forming part of Letters Patent No. 522,232, dated July 3, 1894.

Application filed April 10, 1893. Serial No. 469,670. (No model.)

To all whom it may concern:

Be it known that I, JOSEPH SACHS, a citizen of the United States, residing in the city and State of New York, have invented an Improvement in Electric Safety-Fuses, of which the following is a specification.

The present invention is for the purpose of preventing the dangerous flash in burning the fuse when the same becomes heated by an excess of current. Previously in protecting an electric circuit, lamps or instruments by a fusible wire, which generally consists of lead or an alloy of lead and tin or similar metal, the fuse was so gaged as to burn out or melt and break the circuit as soon as the maximum of its carrying capacity was exceeded and the metal often was volatilized and to so great an extent as to cause injury to surrounding substances. Although this difficulty has been more or less diminished by previous apparatus and methods, it has never been entirely done away with. By my improvement herein described such flashing or flaring of the safety fuse is entirely stopped.

My invention consists in covering the fusible metal or fuse with a non-inflammable material that is a poor conductor, such as silicic acid, whereby the flash is prevented and the metal converted into a non-conductor.

In the drawings, Figures 1 and 2 represent my improved safety fuse. Fig. 3 shows the supporting block and fuse in section at the line $x x$ of Fig. 2. Fig. 4 shows the fuse incased. Fig. 5 is a perspective view of a receptacle for a liquid material and the safety fuse therein. Fig. 6 represents one of the fuse ends separately. Fig. 7 is a section of the supporting block with the fuse made with eyes for the attaching screws, and Fig. 8 shows the fuse of Fig. 7 separately.

The fuse wire b is preferably made with copper ends $a a'$ by which it is connected in the electric circuit, and this fuse may be provided with terminals $e e$ and placed within recesses in the block B of porcelain or other insulating material. The safety fuse wire is sometimes received at its ends into tubular clips or sockets i , or it may be wound at its ends around the binding screws, as illustrated in Fig. 7. The sockets i may be part

of the ends $a a'$, as shown in Figs. 1, 2, and 3, or they may be separate pieces, as shown in Fig. 4.

I surround the fuse wire with non-conducting material such as silicic acid; this acid is represented at m . The acid may be spread on the entire surface or introduced around the wire in the recess of the block, or it may be applied around the wire between the tubular sockets $i i$, as shown in Fig. 4 or around both the wire and sockets, as shown in Figs. 1 and 2 and retained in position in any convenient manner.

The fusible wire preferably of lead combines with the silicic acid under the action of heat developed by an excess of current and forms a silicate of lead which is a non-conductor and therefore the circuit is broken or opened as effectually as if the fuse were melted or burned away, and all risks from a flash or sparks are prevented.

In Fig. 5, I have represented a cavity D in the insulating block B' and the fusible wire as passing across this cavity from the conductors k , and this cavity is adapted to holding the non-conducting and fire-proof material so that when an excess of current passes through the fusible strip the sparks or flash may be extinguished and the metal of the strip combines more or less with the surrounding material.

I do not limit myself to silicic acid alone as any suitable material or compound may be used that will combine with the metal and form an insulating material.

I am aware that a safety fuse has been loosely introduced into a tube, to insure the ejection of one or both electrodes when the safety fuse gives way. In my improvement the non-conductor of fire-proof material that surrounds the safety fuse being in a holder that is in the form of a recessed block, tube or cavity, the parts are retained in position both before and after the safety fuse gives way.

I claim as my invention—

1. The electric safety fuse, composed of a wire or strip to be melted by an excess of current, in combination with a material surrounding such wire, such as silicic acid, that will

(No Model.)

3 Sheets—Sheet 3.

A. SCHWEITZER.
ELECTRIC ARC LAMP.

No. 522,233.

Patented July 3, 1894.

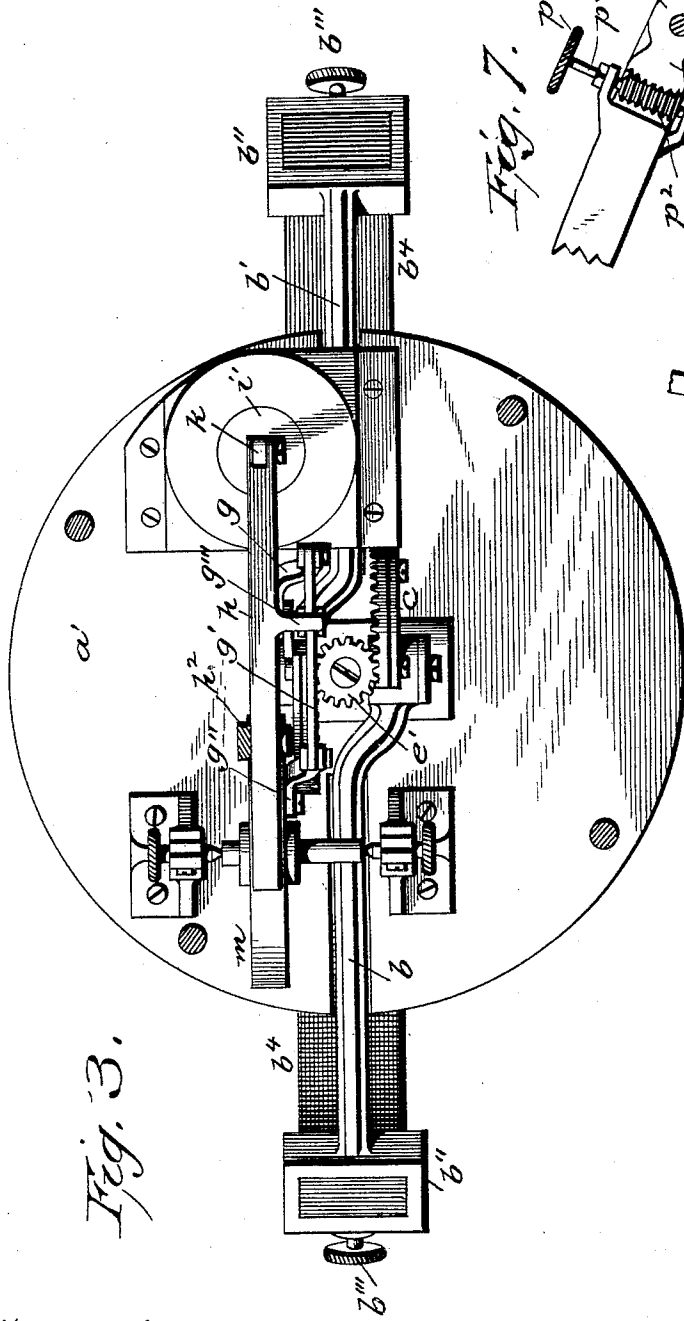

Fig. 3.

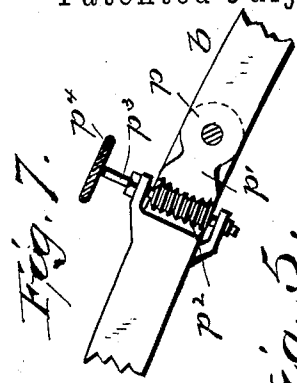

Fig. 7.

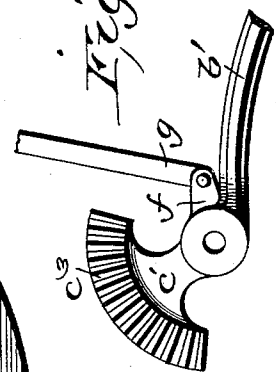

Fig. 5.

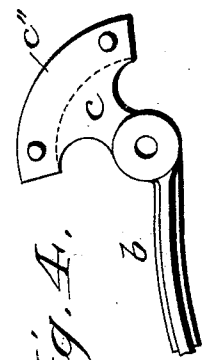

Fig. 4.

Witnesses
[Signature]
[Signature]

Inventor
 Albert Schweitzer

By Attorneys
[Signature]

UNITED STATES PATENT OFFICE.

ALBERT SCHWEITZER, OF ALLEGHENY, PENNSYLVANIA, ASSIGNOR OF TWO-THIRDS TO FREDERICK GOELLNER, OF SAME PLACE, AND CONRAD WEBER, OF SHALER, PENNSYLVANIA.

ELECTRIC-ARC LAMP.

SPECIFICATION forming part of Letters Patent No. 522,233, dated July 3, 1894.

Application filed December 28, 1893. Serial No. 494,984. (No model.)

To all whom it may concern:

Be it known that I, ALBERT SCHWEITZER, a citizen of the United States, residing at Allegheny, in the county of Allegheny and State of Pennsylvania, have invented certain new and useful Improvements in Electric - Arc Lamps; and I do declare the following to be a full, clear, and exact description of the invention, such as will enable others skilled in the art to which it appertains to make and use the same, reference being had to the accompanying drawings, and to the letters of reference marked thereon, which form a part of this specification.

My invention relates to those arc-lamps designated in the art as "gravity-feed" and more particularly to those in which curved carbons are employed and adapted to move in the arc of a circle while in operation.

The labor of frequently renewing the carbons in arc lamps is a source of great trouble and expense in their maintenance. A further difficulty is experienced in the failure of the lamps to so feed the carbon as to entirely consume it thereby leaving a large portion to be thrown away and wasted. By not consuming all of the carbon inserted in the lamp renewal becomes more frequent thus involving much expense and labor to those who supply the lights, and great annoyance to the user. The size of the ordinary arc lamp is often an additional objection to their popularity.

Now it is the purpose of my invention to overcome the above mentioned difficulties by producing a lamp which will occupy a smaller space, one which will be more simple in construction, and more complete in its consumption of the carbons, and consequently one which will run longer without attention.

With these ends in view my invention consists in the peculiar features and combinations of parts more fully described hereinafter and pointed out in the claims.

In the accompanying drawings Figure 1 represents a front elevation of my complete device; Fig. 2, a side elevation; Fig. 3, a top view; Figs. 4 and 5, views of detail, and Fig. 6, a front view of a modified form of the segmental gears and their pinion for the carbon

holders. Fig. 7, is a detail view showing the means whereby the hinged sections of the carbon supporting arms are adjusted laterally to align the carbons.

The carbon holders consist of a pair of diverging metallic arms b and b' , having at their free ends sockets b^2 provided with thumb screws b^3 . These sockets are rectangular within for the reception of curved carbons b^4 rectangular in cross-section. The arms b and b' are pivoted or fulcrumed on a common axis b surrounded by a suitable insulation and formed of an ordinary bolt or screw which passes through a post e rising from a plate a' which forms a part of the frame. Rigidly fixed to or formed integral with the arms b and b' are a pair of segmental arms c and c' having teeth c^2 , c^3 , on their contiguous faces, the whole forming, as it were, a scissors-like mechanism. Interposed between these gears and meshing therewith is a conical pinion e' loosely mounted on the post e . A short arm f is attached to the gear c' and this arm has its outer end also attached to a downwardly extending link g which connects with a lever g' fulcrumed on an arm g^3 depending from a lever h above. The lever h is fulcrumed at h' in a hanger h^2 depending from the frame plate a above. The right-hand end of the lever h is pivotally connected to the armature i of a solenoid j through the medium of the rod k . This rod is limited in its downward movements by a nut k' and in its upward movements by an electro-magnet i' . The tail n^3 of the lever h extends over and is adapted to come in contact with the periphery of a wheel m whenever the armature is attracted to the magnet. This wheel is provided with a counter-balance m' , which balances the carbon holders and carbons. Connected to the bottom of the armature i is a spring n attached to the upper end of an adjusting screw n' whereby the armature is drawn downward against the action of the electro-magnet, the nut permitting the spring to be of any desired tension.

The electric current enters the lamp by way of the positive binding-post o , wire o' , through coil or solenoid j , thence through wire o^2 to holder b' from whence it passes to the car-

bons. Passing through the carbons it makes its exit by way of the carbon *b* and wire *o*³ and binding-post *o*⁴, all of which will be more clearly seen in Fig. 2. In order to permit the arms *b* to be adjusted laterally so as to bring the carbon points in true position, one or both of said arms are provided with a hinge-joint *p*. One of the sections of this joint is provided with a segmental gear *p*¹ which is engaged by an operating worm *p*² extending transversely through the arm and actuated by a spindle *p*³ and button *p*⁴.

To further assist in the proper feeding of the carbons I sometimes employ sectors of different radii, as shown on the modification in Fig. 6. These sectors operate in the same manner as do those previously described, excepting that the smaller sector, which is attached to the arm *b*, engages the lower end of a pinion *e*¹ which moves in unison with an additional pinion *e*² above, which in turn is adapted to engage a sector of larger radius on the arm *b*¹, whereby when either of the two sectors is actuated, whether by gravity or by the electro-magnet, the arm attached to the smaller sector and which carries the positive carbon will be made to travel faster than the one attached to the larger sector, and thereby compensate for the unequal consumption of the carbons, and always keep the arc located centrally below the lamp.

It is evident that my invention might be varied in many other particulars without departing from the spirit and scope of the device, therefore I wish it understood that I do not limit myself to the exact construction herein shown and described.

The preferred construction of my invention having thus been set forth I will now proceed to describe its operation.

Before the electric current is switched into the lamp the gravity of the carbon holders and carbons will keep the latter in contact with each other, but when the current is allowed to pass through the lamp it enters the coils of the solenoid *j* and magnetizes the electro-magnet *i*¹ which attracts the armature *i* and causes the latter to move upward, thereby lifting the lever *h*, which in turn lifts the lever *g*¹ and raises the short arm *f* through the medium of the link *g*. The raising of the short arm *f* actuates the segment *c*¹ downwardly and causes a similar movement, in an opposite direction, of the segment *c*, through the medium of the loose pinion *e*, thereby lifting the holder arms *b* and *b*¹ and moving the carbons away from each other a sufficient distance to produce the arc. If the carbons are moved too far away from each other the power of the electro-magnet will be diminished and they will gravitate back until the proper equilibrium is established. Simultaneous with the lifting of the lever *h*, the wheel *m*, is given a partial rotation backward, and lifts the counter-balance *m*¹. The parts are so timed that the tail *h*³, of the lever will engage the periphery of the wheel *m*, and form a brake on the wheel

at a time which will prevent the too sudden retreat of the carbons. The brake will also tend to check the downward movement of the counter-balance. The withdrawal of the current from the solenoid *j* relaxes the energy of the electro-magnet *i*² and the spring *n* pulls down the armature *i*, thereby causing a reversal of the movements previously described, of the other parts of the mechanism. By means of the nut *k*¹, on the rod *k*, and the thumb nut *n*¹, the requisite amount of play can be given to the armature *i* to adapt it to the exigencies of the occasion.

The advantages of my mechanism, which are most prominent, are that it occupies an exceedingly small space, will feed the carbons in such a manner as to more completely consume them, and keep the light running longer, and will always keep the arc centrally located in relation to the lamp whereby the light is rendered most efficient.

Having thus described my invention, what I claim as new, and desire to secure by Letters Patent, is—

1. In a gravity feed arc lamp, the combination of pivoted arms provided with carbon holders and having segmental gearing, an idle pinion for transmitting motion from one to the other of the arms, a counterbalance, an equalizing lever connected at its ends, respectively, with the said counterbalance and one of the said arms, and a pulsating armature operatively connected with and adapted to control the movements of the said counterbalance and the pivoted arms, substantially as described and for the purpose specified.

2. In a gravity feed electric arc lamp, the combination of pivoted arms provided with carbon holders and having segmental gearing, an idle pinion for transmitting motion from one to the other of the arms, a counterbalance, an equalizing lever connected at its ends, respectively, with the said counterbalance and one of the said arms, a second lever having connection with the equalizing lever and adapted to engage with the counterbalance and control the movement thereof, and a pulsating armature operatively connected with the said second lever, substantially as described.

3. In a gravity feed electric arc lamp, the combination of pivoted arms provided with carbon holders and having segmental gearing, an idle pinion for transmitting motion from one to the other of the arms, a counterbalance wheel operatively connected with the carbon holding arm, a lever having connection with the said arm and adapted to engage with the counterbalance wheel, and a pulsating armature to control the movements of the said lever, substantially as described.

4. In a gravity feed electric arc lamp, the combination of pivoted arms provided with carbon holders and having segmental gearing, an idle pinion for transmitting motion from one to the other of the arms, a counterbalanced wheel, an equalizing lever connected,

respectively, with the counterbalanced wheel and one of the carbon holding arms, a second lever having connection with the equalizing lever, and having its end extended and adapted to engage with the counterbalanced wheel, substantially as described.

5
10
15
5. In a gravity feed electric arc lamp, the combination with oppositely extending arms for supporting the carbons, one of the said arms having a hinged joint, of means for adjusting the hinged section laterally to align and bring the carbon points in coincidental relation, substantially as specified.

6. In a gravity feed electric arc lamp, the combination with oppositely extending arms

for supporting the carbons, one of the said arms having a hinged joint, a segment attached to one section, and a worm attached to the other section of the hinged arm and meshing with the said segment to adjust the hinged section laterally to bring the carbons in alignment and their points in register, substantially as described.

In testimony whereof I affix my signature in presence of two witnesses.

ALBERT SCHWEITZER.

Witnesses:

EDOUARD WEIBBER,
LEO. RAPP.