

FIG 1

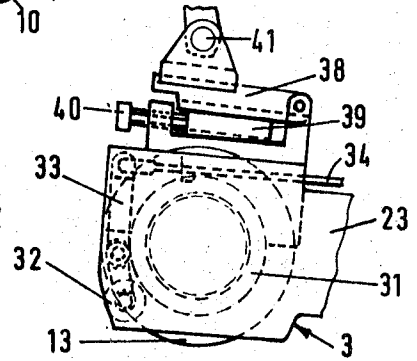

FIG 2

INVENTOR
ANGUS MURRAY HALLEY
By: Norris & Bateman
Attys

ROTARY WEB PROCESSING MACHINES

This is a continuation of my application Serial No. 546,939 filed May 2, 1966 for ROTARY WEB PROCESSING MACHINES, now abandoned.

This invention relates to web processing machines, especially including rotary printing and rotary embossing presses, and is more particularly concerned with the setting up and maintenance of the impression or nip pressure between the impression cylinder and the printing or embossing cylinder of such presses. For simplicity the printing or embossing cylinder is generically hereinafter referred to as the processing cylinder.

In the prior art the nip pressure has been maintained by mounting either the impression cylinder or alternatively the processing cylinder in a cradle supported by fluid powered piston and cylinder units so that either the impression cylinder is movable with respect to a fixed processing cylinder, or vice versa, to control the nip pressure during web processing.

It has been found that the use of an impression cylinder capable of movement during web processing leads to considerable difficulties in maintaining accurate register of color to color or color to embossing in multistation web processing press due to variation in web length between the impression cylinders of the plurality of individual machines. This disadvantage is avoided by using a relatively fixed impression cylinder in conjunction with a processing cylinder capable of movement during web processing to control the impression pressure. However, different processing operations may require impression and processing cylinders of different diameters giving rise to problems in setting up the nip pressure before web processing and problems arising from the relative positions of the impression cylinders of two or more processing machines. The present invention has for its objects to overcome or at least reduce these problems.

The invention consists of a rotary web processing machine wherein nip pressure between cylinder and a processing cylinder is controlled during processing of the web by stepless generally radial movement of the processing cylinder, comprising:

1. Cradle means adapted to carry the impression cylinder and pivotally mounted in a frame of the machine so as to permit stepless generally radial displacement of the axis of rotation of the impression cylinder;
2. Means for effecting angular movement of the cradle before web processing and for maintaining constant position of the cradle means during web processing; and,
3. Means for presetting the axis of the processing cylinder in a radially constant position during the angular movement of the cradle means before web processing.

Preferably the aforesaid means for effecting angular movement of the cradle and for maintaining a selected position of the cradle and its impression cylinder comprises screw jacks and/or fluid powered piston and cylinder units connected between the cradle and machine frame.

Preferably also there is provided a second cradle pivotally mounted in the machine frame and adapted to carry the processing cylinder to permit approximately radial movement of the processing cylinder about an axis parallel to and spaced from the axis of the latter cylinder, with piston and cylinder units interconnecting the second cradle and frame to effect the angular movement of the second cradle and to maintain nip pressure during web processing.

One example of the practical realization of the invention as applied to web printing is illustrated in the accompanying schematic drawings wherein:

FIG. 1 shows in side elevation the more important parts of a printing machine according to the invention with portions of the fixed frame of the machine broken away for greater clarity, and

FIG. 2 is a detail of FIG. 1 on an enlarged scale.

In a multistation printing press there is provided in series connection a plurality of machines each as illustrated in the drawings. Referring now to the drawings, each machine com-

prises a fixed frame 1 carrying a pair of angularly movable lower and upper cradles 2 and 3. The lower cradle 2 embodies or is adapted to carry a subframe 4 providing a mounting for a printing cylinder 5 and this cradle is fulcrumed on the frame 1 about an axis 6 spaced from and parallel to the axis of rotation 7 of the printing cylinder. The lower cradle 2 comprises two parallel and interconnected arms each of L-shape in elevation with their horizontal limbs pivotally connected at 8 to the upper ends of a pair of respective piston and cylinder units 9 anchored at lower pivots 10 to the frame 1. The cylinders 9 are connected via an adjustable pressure regulator 11 to a source 12 of fluid pressure, preferably air pressure. By means of these piston and cylinder units 9 the printing cylinder 5 is raised and lowered with respect to a relatively fixed impression cylinder 13 so as to control the nip pressure during processing of the web.

Also mounted on the same subframe 4 as the printing cylinder 5 is ancillary equipment such as for example an ink supply system and doctor device (not shown). The subframe 4 rests upon the cradle 2 during web processing and can be readily inserted and withdrawn from the machine together with the printing cylinder and ancillary equipment as a single self-contained unit by bringing wheels 14 into engagement with tracks on tie bars interconnecting the cradle arms by manual rotation of a hand wheel 16 fixed to a crank shaft 15 providing an eccentric mounting of the wheels with respect to the mounting for the shaft.

As an alternative to the cradle, the printing cylinder can be otherwise mounted for generally vertical sliding mounting in the fixed frame and urged towards the axis of the impression cylinder to establish the nip for example by variable counterbalance weights, or by adjustable spring pressure.

In both forms of printing cylinder mounting two position stop means is provided to determine in a first position a limit to the upward movement of the axis of the printing cylinder 5 towards the axis of the impression cylinder 13 in setting up the machine prior to the commencement of the processing of a web, and in a second position to permit the axis of the printing cylinder to move beyond this limit towards the axis of the impression cylinder during the processing operation.

In the illustrated embodiment the stop means comprises a pair of abutments 17 provided on the cradle 2 which lie adjacent to a respective pair of second abutments 18 in the form of discs fast on a shaft 19 rotatably mounted in the frame 1 and manually rotatable by a hand piece (not shown). Contact of the first abutments 17 with circular parts of the periphery of the second abutments upon angular movement of the cradle 2 under thrust from the cylinder units 9 establishes a given vertical position of the axis of the axis of the printing cylinder 5 whereas rotation of the shaft 19 to position a flat 20 on the discs opposite the first abutments permits further upward stepless movement of the printing cylinder 5 to establish and maintain a nip pressure dependent on the selected fluid pressure within the cylinders 9.

To limit the downward movement of the cradle 2 and printing cylinder 5 when the cylinder units 9 are inoperative, lateral lugs 21 on extensions of the cradle 2 above the fulcrum 6 move within slots 22 in the frame to abut one end of the slots.

The upper cradle 3 comprises a pair of parallel arms 23 pivotally mounted at one end 24 on respective eccentrics 25 fast on a shaft 26 driven by a sprocket 27 connected by chain 28 to a second sprocket 29 rotatable by a hand wheel 30. Rotation of the hand wheel 30 serves to turn the eccentrics 25 to alter the position of the cradle arm pivots 24 to suit the diameters of impression and printing cylinders in use, the lowermost position of the pivots 24 being illustrated in broken lines.

The ends of the cradle arms 23 remote from their pivots have arcuate bearing recesses whereby they are adapted to accommodate impression cylinder bearings 31 when the impression cylinder has engaged against the printing cylinder. When these cylinders are separated, rollers 32 mounted on levers 33 retain the impression cylinder bearings 31 in position until

rocked to release the bearings by means of connecting rods 34 coupling the levers 33 to a manually operated lever 33 fulcrumed on the cradle 3.

The upper cradle 3 is both fixed and steplessly angularly adjusted with respect to its pivots 24 during web processing and setting up of the machine respectively by means of respective inverted screw jacks 36 connecting the free ends of the cradle arms 23 directly above the axes of the cylinders 5 and 13 to the frame 1 and adjustable in length by a hand wheel 37. To afford relative adjustment between the height of the two free ends of the cradle arms 23 to achieve accurate parallelism between the axes of the two cylinders, the lower ends of the screw jacks are pivotally connected to respective elements 38 pivotally mounted on the cradle arms 23 and angularly adjustable with respect of these arms by the interaction of wedge faces on the elements and wedges 39 disposed between the elements and arms. Screws 40 controlling the position of the wedges 38 thus control the distances between the respective jack to cradle arm pivots 41 and the impression cylinder axis.

A pair of fluid powered piston and cylinder units 42 are pivotally interconnected between the upper cradle arms 23 and frame 1 and when energized act to raise the cradle arms 23 and so serve to take up any backlash in the screw jacks 36. The screw jacks are of low pitch so that there is no alteration in their length due to the nip pressure with the result that the axis of the impression cylinder is effectively fixed in the position selected by the jacks.

It is to be understood that the impression cylinder cradle 3 can be adjusted and fixed by alternative means to that described. For example, the cradle can be thrust by fluid powered piston and cylinder units against rotary adjustable eccentric stops providing a stepless angular movement of the cradle.

The web 43 is guided to and from the nip by idle rollers 44.

In setting up a multistation press, the required impression and printing cylinders are mounted in their respective cradles in each machine. In each machine the printing cylinder 5 is then positioned in approximately its operating position by application of fluid pressure to the cylinder 9 supporting the lower cradle 2 and the resultant upward movement of the cradle 2 and printing cylinder 5 towards the impression cylinder 13 is limited by contact of abutments 17 on the cradle 2 with the circular parts of the peripheries of the discs 18 thereby accurately locating the axis of the printing cylinder 5 in a given position.

With the lower cradle 2 fixed in the aforesaid given position by maintained fluid pressure, the upper cradle pivots 24 are adjusted as necessary to suit the diameters of the cylinders 5 and 13, and with fluid pressure applied to the cylinder units 42 the jacks 36 are adjusted in length by the hand wheel 37 to provide continuous (i.e. stepless) generally radial adjustment of the impression cylinder until a sample piece of the web to be processed is lightly nipped between the surfaces of the impression and printing cylinders 5 and 13. Also, any necessary adjustment is made in the wedges 39 to achieve a parallel relationship between the cylinders.

Fluid pressure is now relaxed in the lower cradle supporting

cylinders 9 to allow the web to be processed to be fed through the several machines.

To process the web, the rotatable stops 19 are now turned to present their flats to the cradle abutments 17 and fluid pressure is reapplied to the lower cradle cylinders 9 so resiliently urging the printing cylinder 5 into unrestricted contact with the impression cylinder 13 to establish and maintain a nip pressure determined by the selected fluid pressure in the lower cradle supporting cylinder 9 with provision by means of the pressure regulator 11 for variation in this nip pressure as necessary to perform satisfactorily the printing operation.

By the aforesaid means it will be appreciated that after setting up of the several machines, printing can be arrested in any machine by lowering of a printing cylinder, for example for servicing, or printing cylinder exchange, without alteration in length of the web between adjacent impression cylinders and therefore without loss of register between the machines on resumption of printing.

Whereas the invention has been described with reference to direct printing it will be realized that the invention is equally applicable for example to embossing or offset printing machines or a combination of these machines with appropriate substitution of embossing or offset printing cylinders for the above described cylinders.

I claim:

1. In a rotary web processing apparatus, a frame, an impression cylinder, means mounting said impression cylinder on said frame and permitting stepless generally radial movement of said impression cylinder during setting up of said apparatus, means for effecting movement and fixation of the radial position of said impression cylinder during setting up and web processing respectively, said impression cylinder mounting means comprising cradle means adapted to carry the impression cylinder, eccentric means pivotally mounting said cradle means on said frame, and means for adjusting said eccentric means for effecting adjustment in height of said cradle means pivot axis and means connected between said impression cylinder cradle means and said frame to effect both the stepless adjustment of the radial position of said impression cylinder and cradle means and their fixation in a selected radial position, a processing cylinder, means mounting said processing cylinder on said frame adjacent said impression cylinder and resiliently permitting stepless generally radial movement of said processing cylinder relative to said impression cylinder during web processing, means for moving said processing cylinder towards said impression cylinder, and adjustment means having a first position in which the movement of said processing cylinder mounting means is positively limited during setting up of said apparatus to establish a predetermined limit position of said processing cylinder with respect to said impression cylinder and a second position in which movement of said processing cylinder mounting means and processing cylinder towards said radially fixed impression cylinder is substantially unrestricted to maintain the nip pressure between said processing and impression cylinders during web processing.

60

65

70

75