

W. BULKELEY.
Barrel Hoisting Clamp.

No. 201,648.

Patented March 26, 1878.

Fig. 1.

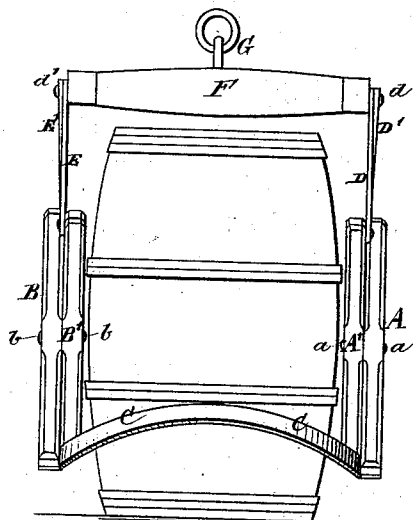
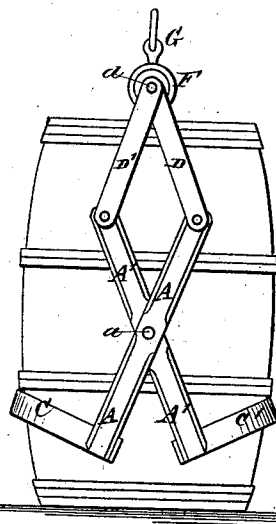

Fig. 2.



WITNESSES:

Henry W. Miller
C. Sedgwick

INVENTOR:

W. Bulkeley
BY *Mumford*

ATTORNEYS.

UNITED STATES PATENT OFFICE.

WORTHINGTON BULKELEY, OF BALLSTON SPA, NEW YORK.

IMPROVEMENT IN BARREL-HOISTING CLAMPS.

Specification forming part of Letters Patent No. **201,648**, dated March 26, 1878; application filed March 6, 1878.

To all whom it may concern:

Be it known that I, WORTHINGTON BULKELEY, of Ballston Spa, in the county of Saratoga and State of New York, have invented a new and Improved Barrel-Hoisting Clamp, of which the following is a specification:

The object of my invention is to furnish a simple, strong, durable, and conveniently-adjusted device for clamping and holding barrels while they are being hoisted.

The invention consists in the combination of two pairs of pivoted levers, connected at their lower ends by two curved or semicircular cross-bars, and connected at their upper ends to the opposite ends of a common cross-bar by two pairs of connecting bars or links, as will be hereinafter described.

In the accompanying drawings, Figure 1 is a side view, and Fig. 2 is an end view (or seen at right angles to Fig. 1) of my improved hoisting-clamp attached to a barrel and in position for use.

Similar letters of reference indicate corresponding parts.

A A' are the two members of a pair of levers, secured together at their centers by the pivot *a*. B B' are the two members of another pair of levers, secured together at their centers by the pivot *b*.

The lower ends of the two levers A B of the opposite pairs are connected together by the curved cross-bar C, bent in such manner as to be adapted to partially encircle a barrel, and the lower ends of the two levers A' B' are connected together by the cross-bar C', curved similar to C.

The upper ends of the levers A A' are pivoted to the lower ends of the connecting links or bars D D', respectively, the upper ends of

which latter are secured by a common pivot, *d*, to one end of the cross-bar F.

The upper ends of the levers B B' are pivoted to the lower ends of the connecting links or bars E E', respectively, the upper ends of which latter are secured by a common pivot, *d'*, to the other end of the cross-bar F.

The above-described elements constitute, together, my improved hoisting-clamp for barrels.

To adjust it for use, the clamp should be let down over the barrel until the curved bars C C' get in position to encircle and impinge upon the opposite sides of the barrel, below its center, as in Fig. 2.

The clamp being suspended by attaching the hoisting-rope to the ring and staple G, it is evident that the first effect of the hoisting will be to tighten the gripe of the clamp on the barrel, the firmness of the hold increasing with the weight of the barrel.

I do not limit myself to the exact form of any of the parts here shown, as they may be varied without departing from my invention.

Having thus described my invention, I claim as new and desire to secure by Letters Patent—

The combination of the two pairs (A A' and B B') of pivoted levers, connected at their lower ends by the two curved or semicircular cross-bars C C', and connected at their upper ends to the opposite ends of the common cross-bar F by two pairs (D D' and E E') of connecting bars or links, substantially as and for the purpose set forth.

WORTHINGTON BULKELEY.

Witnesses:

S. C. MEDBERY,
CHAS. E. FITCHUM.