



INTERNATIONAL APPLICATION PUBLISHED UNDER THE PATENT COOPERATION TREATY (PCT)

<p>(51) International Patent Classification ⁷ : G06F</p>	<p>A2</p>	<p>(11) International Publication Number: WO 00/48058 (43) International Publication Date: 17 August 2000 (17.08.00)</p>
--	------------------	---

(21) International Application Number: PCT/US00/00608
(22) International Filing Date: 11 January 2000 (11.01.00)

(30) Priority Data:
60/119,378 9 February 1999 (09.02.99) US
60/125,658 22 March 1999 (22.03.99) US
09/317,388 24 May 1999 (24.05.99) US

(71) Applicant (for all designated States except US): ELITE LOGISTICS SERVICES, INC. [US/US]; 1201 N Ave. H, Freeport, TX 77541 (US).

(72) Inventors; and
(75) Inventors/Applicants (for US only): SMITH, Joseph, D. [US/US]; 2511 Deep Sea Drive, Freeport, TX 77541-9102 (US). HIGGS, Austin, L. [US/US]; 110 Acacia Street, Freeport, TX 77566-5330 (US). NGUYEN, Thien, K. [US/US]; 2514 Deep Sea Drive, Freeport, TX 77541-9102 (US).

(74) Agent: NASH, Kenneth, L.; P.O. Box 680106, Houston, TX 77268-0106 (US).

(81) Designated States: AL, AM, AT, AU, AZ, BA, BB, BG, BR, BY, CA, CH, CN, CU, CZ, DE, DK, EE, ES, FI, GB, GE, GH, GM, HR, HU, ID, IL, IS, JP, KE, KG, KP, KR, KZ, LC, LK, LR, LS, LT, LU, LV, MD, MG, MK, MN, MW, MX, NO, NZ, PL, PT, RO, RU, SD, SE, SG, SI, SK, SL, TJ, TM, TR, TT, UA, UG, US, UZ, VN, YU, ZW, ARIPO patent (GH, GM, KE, LS, MW, SD, SL, SZ, TZ, UG, ZW), Eurasian patent (AM, AZ, BY, KG, KZ, MD, RU, TJ, TM), European patent (AT, BE, CH, CY, DE, DK, ES, FI, FR, GB, GR, IE, IT, LU, MC, NL, PT, SE), OAPI patent (BF, BJ, CF, CG, CI, CM, GA, GN, GW, ML, MR, NE, SN, TD, TG).

Published
Without international search report and to be republished upon receipt of that report.

(54) Title: TRACKING, CONTROL, AND LOGISTICS SYSTEM AND METHOD

(57) Abstract

A system, apparatus, and method are disclosed for monitoring, tracking, and logistics purposes that preferably includes a monitoring unit (10) wherein data is processed using a microcontroller. The monitoring unit includes an interface (40, 66) with the target (114) or asset to be tracked such that electrical signals may be sent between the target (114) and monitoring unit (10) to denote events from the target, e.g., air bag deployment and for activating features of the target, e.g., an alarm. The interface (40, 66) may be unique for each monitoring unit because unique information relating to each interface is stored in the system database (106), e.g., data may be related to a temperature in one unit and to a movement sensor indication in another. Therefore, the system (100) may respond appropriately to signals having unique meanings from each different monitoring unit (10). The server (110) may be accessed by multiple clients (108) over the Internet or other lines of communication so that the clients at numerous different remote locations may activate controls on their respective one or more remote targets/assets (10, 114), find the locations thereof, and receive cumulative status reports.

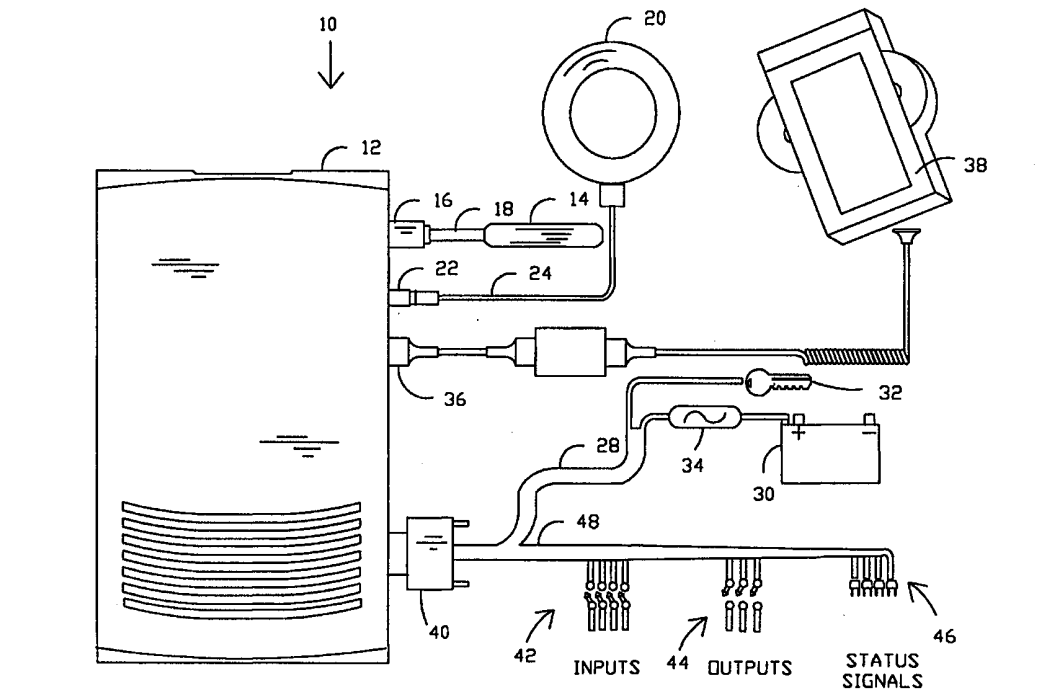

Therefore, the system (100) may respond appropriately to signals having unique meanings from each different monitoring unit (10). The server (110) may be accessed by multiple clients (108) over the Internet or other lines of communication so that the clients at numerous different remote locations may activate controls on their respective one or more remote targets/assets (10, 114), find the locations thereof, and receive cumulative status reports.

FOR THE PURPOSES OF INFORMATION ONLY

Codes used to identify States party to the PCT on the front pages of pamphlets publishing international applications under the PCT.

AL	Albania	ES	Spain	LS	Lesotho	SI	Slovenia
AM	Armenia	FI	Finland	LT	Lithuania	SK	Slovakia
AT	Austria	FR	France	LU	Luxembourg	SN	Senegal
AU	Australia	GA	Gabon	LV	Latvia	SZ	Swaziland
AZ	Azerbaijan	GB	United Kingdom	MC	Monaco	TD	Chad
BA	Bosnia and Herzegovina	GE	Georgia	MD	Republic of Moldova	TG	Togo
BB	Barbados	GH	Ghana	MG	Madagascar	TJ	Tajikistan
BE	Belgium	GN	Guinea	MK	The former Yugoslav Republic of Macedonia	TM	Turkmenistan
BF	Burkina Faso	GR	Greece			TR	Turkey
BG	Bulgaria	HU	Hungary	ML	Mali	TT	Trinidad and Tobago
BJ	Benin	IE	Ireland	MN	Mongolia	UA	Ukraine
BR	Brazil	IL	Israel	MR	Mauritania	UG	Uganda
BY	Belarus	IS	Iceland	MW	Malawi	US	United States of America
CA	Canada	IT	Italy	MX	Mexico	UZ	Uzbekistan
CF	Central African Republic	JP	Japan	NE	Niger	VN	Viet Nam
CG	Congo	KE	Kenya	NL	Netherlands	YU	Yugoslavia
CH	Switzerland	KG	Kyrgyzstan	NO	Norway	ZW	Zimbabwe
CI	Côte d'Ivoire	KP	Democratic People's Republic of Korea	NZ	New Zealand		
CM	Cameroon			PL	Poland		
CN	China	KR	Republic of Korea	PT	Portugal		
CU	Cuba	KZ	Kazakstan	RO	Romania		
CZ	Czech Republic	LC	Saint Lucia	RU	Russian Federation		
DE	Germany	LI	Liechtenstein	SD	Sudan		
DK	Denmark	LK	Sri Lanka	SE	Sweden		
EE	Estonia	LR	Liberia	SG	Singapore		

TRACKING, CONTROL, AND LOGISTICS SYSTEM AND METHOD**BACKGROUND OF THE INVENTION**

5 This application claims benefit of U.S. Provisional Application No. 60/119,378
filed February 9, 1999 and U.S. Provisional Application No. 60/125,658 filed March 22,
1999.

1. Field of the Invention

10

The present invention relates generally to remote tracking, control, and logistics
and, more particularly, to apparatus, systems and methods for remotely controlling one
or more devices and/or remotely tracking one or more assets such as cars, trucks, ships,
cargo, and the like.

15

2. Description of the Background

For the most part, it is expensive and difficult to monitor moveable assets such
as cargo, vehicles, trucks, cargo containers, and the like. It would be desirable to provide
20 a low cost, reliable device with the ability to locate assets anywhere and anytime. It
would also be desirable to communicate between the asset and a central control center
using any type of required data or information. Moreover, it would be desirable to enable
the remote control center or a client at any location to initiate command and control
functions to the assets or targets which may also be at any location in the world. The
25 advantages of such a system would include the availability of near real time information

and data which in turn would allow for maximum asset utilization and control at a greatly reduced cost of operation. An affordable device of this type would place proper equipment and materials at the right location during an upset condition response and allow real time monitoring of those assets.

5 As only one example, it would be desirable to remotely monitor the location of a vehicle in a cost-effective manner. Presently existing systems can achieve this function but the costs are prohibitive for general usage. The presently available lowest cost systems use a global positioning satellite system (GPS) sensor in conjunction with a cellular telephone-based modem. As is well known, the GPS sensor communicates with
10 satellites to obtain location information for the sensor. A computer control interfaces between the vehicle inputs and outputs, the GPS sensor, and the cellular modem in accord with demands of the interface/software control between the cellular modem and cellular telephone. While these systems are able to some degree to perform the desired functions discussed above, the equipment costs of such systems are prohibitive for general usage.
15 On top of the very high initial equipment cost, the supporting operating service cost is quite high. It would be desirable to provide a system capable of the same and additional functions that costs a fraction of presently available systems both for initial equipment costs and for operating service cost. In this way, the useful features of such systems could be effectively utilized in a great many applications such as affordable auto tracking
20 and control as well as for many other purposes.

Consequently, there remains a need for a system and method for remote tracking, control, and logistics that is available at greatly reduced levels of capital investment as compared to systems available today as well as being operable for a fraction of the operating costs of present systems so as to be widely affordable. Those skilled in the art

have long sought and will appreciate the present invention which addresses these and other problems.

SUMMARY OF THE INVENTION

The present invention provides a device which costs a fraction of presently available devices and also operates at a fraction of the cost of presently available services that allow for monitoring, controlling, and logistics. The device and system of the present invention permits usage on a wide scale due to its low cost. A wide range of targets or assets can be monitored by the present invention including but not limited to vehicles, trains, cargo, ships, persons, utility units, buildings, and other targets.

For this purpose, one preferred embodiment of the monitoring device for monitoring a target comprises a microcontroller programmed for operating the monitoring device. A pager controlled by the microcontroller is operable for communicating with a pager network. A pager modem is provided for interfacing with the pager for communicating over the pager network. A global positioning sensor is included for providing location information. An interface is provided between the monitoring device and the target for communicating signals relating to the target.

Preferably, a computer port is provided for connecting the monitoring device to a computer to allow communication between the computer and the pager network. In this way, the pager modem and the microcontroller is operable for sending email messages over the pager network. The pager is preferably operable for both sending and receiving signals over the pager network. A plurality of inputs to the monitoring device from the target are provided as well as plurality of outputs from the monitoring device to the target. If the target is a vehicle, then the interface communicates electrical signals relating to one or more elements of the vehicle.

The microcontroller is programmed in a low level language closely related to an architecture of the microcontroller. The low level programming language provides that

the microcontroller is programmed to collect data from the global positioning sensor, send data through the modem, receive messages from the modem and communicate with the interface or with the global positioning sensor in response to the messages. As a security precaution, the microcontroller preferably has no port that allows access for
5 reading the program.

In one embodiment of the invention for use with nonmoving targets such as utility meters, home or building security, offshore platform, well pumps, or any other fixed structure or device and/or for moving devices where location information is not desired, the GPS is removed from the monitoring device. The programming allows the device
10 to continue to operate with respect to other features.

The preferred system of the invention includes a pager network operable for communication with a plurality of pagers. In one embodiment, an Internet connection is provided for communication with the pager network. One or more computers having an Internet connection are operable for communicating over the Internet connection to detect
15 the target signals. Preferably, the one or more computers are operable for sending a target control signal through the Internet connection for controlling one or more features of the target.

Where the monitor includes a GPS, then the one or more computers is operable for communicating over the computer connection through the pager network to determine
20 a location of the respective target. For this purpose, a server is provided in communication with the pager network, and one or more computers are operable for communicating over the server and through the pager modem to detect the one or more target signals.

Preferably a database is provided for storing signals relating to the target either

for communication with the one or more computers. The database also preferably provides information about each target and the definition/response for each target signal.

In the method of the invention, a pager with a pager antenna is attached to the target. An electrical interface is provided for the target such that one or more electrical
5 signals may be received from the target through the electrical interface. Encoding of a message to a pager modem to form a modem-encoded message relating to the one or more electrical signals from the target is provided using a microcontroller in combination with the electrical interface, the pager modem, and the pager with a microcontroller. The modem-encoded message is transmitted through the pager using the pager antenna.

10

Preferably the microcontroller repeatedly checks the electrical interface for the one or more electrical signals from the target. A message may be transmitted from a pager network to the pager, received through the pager modem, and result in execution of a command responsive to the message. In another case, a global
15 position may be determined and a message encoded to a pager modem to form a global position message based on the global position. The global position message is transmitted through the pager using the pager antenna. The global position message is received through a pager network and in a database. Remote access is provided to the database, such as access over an Internet connection. If the target is a vehicle, then the
20 one or more electrical signals relate to the vehicle. On the other hand the target may be a structure affixed to the Earth so as to be non-moveable. One function of the invention allows for remotely operating the module for enforcing a loan related to the vehicle. It is also possible to remotely operate the module for determining that the vehicle stays within a selectable region.

Preferably, a monitoring system is provided for monitoring a plurality of targets on behalf of a plurality of respective clients in accord with the invention that comprises a computer network server operable for communicating with a plurality of client computers. In this embodiment, a database is operable for storing information

5 relating to each of the plurality of targets. A first wireless network system is operable for communicating wirelessly with a plurality of pagers. The network server is in communication with the pager network system. A plurality of wireless communication units is provided for each of the plurality of targets wherein each of the plurality of wireless communication units is operable for communication with the

10 wireless network. Preferably, each of the plurality of wireless communication units includes a global position sensor to provide location information for each of the plurality of targets. Moreover each of the plurality of client computers is preferably operable for querying the database for the location information relating to one or more of the plurality of targets. The computer network server is preferably operable for

15 communicating with the plurality of client computers over an Internet connection. Preferably, the plurality of client computers are each operable for producing a map showing thereon a geographic picture of one or more of the plurality of targets. Moreover, the plurality of client computers are preferably each operable for making a query to the computer network server to provide updated location information for one

20 or more of the plurality of targets. The computer network server is operable for communicating the query through the wireless network system to respective of the plurality of wireless communication units. Each of the plurality of wireless communication units is operable for responding to the query through the wireless network system, the computer network server and to respective of the plurality of

client computers for providing the updated location information.

In a preferred embodiment, the computer network server is operable for storing the query in the database for operation using a server program for communicating the query to the wireless network system. The server program is operable for storing the
5 updated location information in the database prior to providing the updated location information to a respective of the plurality of client computers.

It may be that at least a portion of the plurality of targets comprises a plurality of transport vessels. A second wireless network system may be used if necessary for communicating with the plurality of transport vessels. The database is also operable
10 for storing vessel location information.

In one embodiment of the invention, a two-way pager may be used for contacting one or more of the plurality of wireless communication units.

In another embodiment of the invention, the pager/modem may be removed from the monitor unit where it is desired to simply track the target during operation
15 based on some criteria in which case the microcontroller is programmable for storing a plurality of records in the memory relating to the target location information. Preferably, a computer may be provided for receiving the plurality of records and producing a map showing a path of movement of the target with respect to a time
20 period. The computer may preferably be operable for comparing the path of movement of the target with a second path of movement for a second target.

Therefore, it is an object of the present invention to provide an improved monitoring device and system.

Another object of the present invention is to provide a device for monitoring at a substantially reduced cost.

Yet another object of the present invention is to provide a system that is operable at a substantially reduced cost.

Yet another preferred object of the present invention is to provide a system that is accessible by numerous clients located anywhere in the world to operate control
5 units also located anywhere in the world for the asset or target of the client.

A preferred feature of the present invention is a low-cost microcontroller programmed in a low level language related to an architecture of the microcontroller.

Another preferred feature of the invention is a pager-based system with a pager modem interface.

10 A preferred advantage of the present invention is that each monitor/target interface can be configured differently because all initialization information is stored in a central database.

Another preferred advantage of the present invention is that some components can be removed where different types of monitoring are desired for lowering costs
15 even further.

The above objects, features, and advantages are not to be construed as limiting the invention in any way but are provided merely as an aid in understanding the ramifications of the invention with respect to presently preferred embodiments of the invention. Moreover, these and yet other diverse objects, features, and advantages of
20 the present invention will become apparent from the drawings, the descriptions given herein, and the appended claims.

BRIEF DESCRIPTION OF THE DRAWINGS

FIG. 1 is a pictorial diagram for a monitoring device in accord with the present invention;

5 FIG. 2 is a block diagram of a system for monitoring a plurality of targets in accord with the present invention;

FIG. 3 is a pictorial schematic for a system for monitoring a plurality of targets in accord with the present invention;

10 FIG. 4 is a flow diagram of programming control for a microcontroller for use in a monitoring device in accord with the present invention;

FIG. 5 is a block diagram of a monitoring device in accord with the present invention; and

15 FIG. 6 is a pictorial diagram representative of a client computer screen showing a location of the client's target, in this case a vehicle, on a map generated by a computer in accord with the present invention.

While the present invention will be described in connection with presently preferred embodiments, it will be understood that it is not intended to limit the invention to those embodiments. On the contrary, it is intended to cover all alternatives, modifications, and equivalents included within the spirit of the invention
20 and as defined in the appended claims.

BRIEF DESCRIPTION OF THE PREFERRED EMBODIMENTS

The present invention provides a unique and low-cost system and method for monitoring a wide range of targets as discussed subsequently. U.S. Provisional
5 Application No.60/119,378, filed February 9, 1999 and U.S. Provisional Application
No. 60/125,658, filed March 22, 1999 are hereby incorporated herein by reference.
Referring now to the drawings, and more particularly to FIG. 1, there is shown a
physical representation of monitoring device 10 in accord with the present invention
and various attachments that might be used with various items to be monitored. Such
10 items are referred to herein generally as targets that are assets of some type which are
desirably monitored. It will be noted that FIG. 5 discloses a block diagram of the
electronics of monitoring device 10 and FIG. 4 discloses a flow diagram for software
used in monitoring device 10.

Enclosure 12 is a relatively small housing that may be conveniently mounted
15 for operation. While the attachments to monitoring device 10 are suitable for use with
a vehicle, monitoring device 10 may be used with many targets such as assets to be
monitored including mobile vehicles such as cars, trucks, ships and/or cargo or assets
that may be transported. The monitoring device may also be used with fixed objects
such as utility meters, houses, various systems as a remote control unit, and other such
20 functions. There is really no limitation on the types of targets/assets with which
monitoring device may be used. For instance, monitoring device 10 might be used for
tracking bicycle messengers or even be used for tracking people. The low cost of the
service for wireless communication and low cost of the monitoring device 10 allow
wide use of the device where cost and size effectively prohibited widespread

monitoring usage in the past. The reasons for the low costs will be explained and become apparent as the components of the system are disclosed and discussed hereinafter.

5 Pager antenna 14 is provided with an appropriate connection 16 and antenna cable 18 of suitable length for the intended application. Global positioning sensor (GPS) antenna 20 is connected at 22 to monitoring device 10 via cable 24. Preferably the antennas 14 and 20 are mounted such that they do not interfere with each other and so the reception is maximized. Various pager and GPS type antennas could be used with monitoring device 10.

10 Cable 28 is used to connect the unit to power. While the type of connection will depend on the application, it will be noted that where necessary for security purposes, monitoring device 10 can be connected to power in such a way that it will be difficult to operate the vehicle if monitoring device 10 is disconnected or otherwise damaged. Various types of labyrinth wiring possibilities for connecting to the ignition
15 system are well known that make it difficult or impossible for operation of a vehicle without rewiring of the ignition system, typically a time consuming project even for a skilled mechanic. If that type of security is not necessary, then such connections are not required.

Monitoring device 10 may be connected to battery power 30 of a vehicle, or
20 other asset to be monitored, in several different ways. For instance, power to monitoring device 10 may be of two types including battery power 30 and ignition power 32. With this power option, some circuits are unpowered and others that draw little power continue to be powered to maintain the settings. For instance, the global positioning sensor (GPS) may be of the type that permits a low power-on function to

prevent the need for initialization of the GPS as may typically be required after all power is turned off to the GPS. The GPS initialization process may otherwise typically take in the range of about 90 seconds to be completed before a position fix may be taken. Another power option is simply to leave all circuits of monitoring device 10 connected to the battery. This option might slowly drain battery 30 but because the monitoring device 10 draws very little power, this will not normally be a problem unless battery 10 is not charged for extended periods. It will also be noted that monitoring device 10 may be programmed to control power itself as discussed subsequently so as to further reduce power usage. Another power option is to connect monitoring device 10 directly to ignition 32 so that power is applied only when the ignition is on. As discussed above, this will typically require an initialization of the GPS and a delay before location fixes can be taken. Other options may also be used. For instance, in some applications it might be desirable to include a battery within monitoring device 10 for various reasons such as to provide emergency power and/or perhaps provide notification of battery power outage, impending battery outage, or other power outage. It will be understood that other types of power such as AC power could possibly be used where desired with suitable converters or that monitoring device 10 may be provided with means for handling AC power. Fuse 34 or other suitable protection means is preferably used for protecting both monitoring device 10 and any circuits to which it is attached.

Computer port 36, which is preferably an RS-232 port, is provided for connecting computer 38 to monitoring device 10. This is an optional connection but will be convenient for use with portable computers. As monitoring device 10 includes a low cost pager modem, there is no need to provide a much more expensive modem

with computer 38. Also, because a pager network is used with monitoring device 10, costs for usage are kept much lower as compared with cellular telephone networks.

Computer 38 may be also be used in connection with monitoring device 10 for debugging and other functions such as downloading recorded information. Computer
5 38 may also be used for E-mail, Internet connections, messaging, and other purposes as desired.

Digital I/O or interface 40 connects inputs 42, outputs 44, and status signals 46 to monitoring device 10 preferably via cabling 48. In a presently preferred embodiment, inputs 42 may include up to four switches, buttons, or sensors. In
10 another embodiment, sixteen inputs or variations might be used where each of the four inputs represents a digital number. It will be noted that because monitoring device 10 is preferably used with system 100 as shown in FIG. 2 or FIG. 3, that inputs for any particular monitoring device 10 may be different, e.g., if there are one thousand monitoring devices 10 in operation, each device may be configured differently. The
15 flexibility comes because during initialization of monitoring device 10, the various inputs 42 and outputs 44 are listed and entered into a database of system 100 where they are defined along with any desired response that a client may wish system 100 to make, e.g., e-mail, telephone call, pager alarm, etc. Inputs to monitoring device 10 for use with a vehicle may include, for example only, a panic button, air bag deployment,
20 siren, lights, auxiliary signals, cargo door sensor (open/close), or a threshold indicator such as cargo temperature exceeds a threshold.

If desired, certain events, e.g., a door opening, may trigger a data reporting signal. For instance, the location of a vehicle could be determined and transmitted each time a door opens. In such a case, the door opening would be programmed into

system 100 with a request to check and store location information. Then, each time the door opened, monitoring device 10 would transmit this event to system 100.

System 100 would request location information from monitoring device 10 and store the information in a database. That information would then be available to the client

5 who would be able to access database information, perhaps with a map as shown in FIG. 6, and as discussed subsequently. As another example, system 100 might be initialized such that an input is designated as an air bag with an emergency response being set up for whenever the air bag deploys. System 100 could be programmed to request location information from monitoring device 10 if the air bag deploys and then
10 automatically request emergency service by providing the location information to police and ambulance services in the area where the air bag deployed.

As an alternative embodiment of the invention, where a large number of units were to be the same, it would be possible to program monitoring device 10 to collect or log information in its own memory. For specific use in data logging, monitoring
15 device 10 would not necessarily even need the pager and pager modem for collecting location information responsive to a trigger signal to reduce the cost of monitoring device 10 even more. Downloading to a computer, such as computer 38 could be accomplished at an appropriate time such as the end of the shift or day, for each vehicle, to determine, for example, routes and for optimization thereof.

20 Monitoring device 10 may be used to produce outputs such as door locks, ignition kill, to produce an audible alarm for the driver, or to effect any other feature that can be electrically interfaced to monitoring device 10. While FIG. 1 indicates up to three outputs, additional outputs may be obtained by using lines that otherwise provide status signals 46 as outputs. If necessary, a digital circuit could conceivably

be used to produce up to 16 different outputs based on using the same four output lines to provide a code. Thus, numerous different outputs may be used. Moreover, system 100 can remotely control the outputs. Thus, a client who logs onto system 100 through the Internet, and who may be in another country, can effect a desired output
5 through monitoring device 10. Status signals 46 may typically include LED indicators to show power on, the battery is ok, communication is in progress, GPS is obtaining a fix, and the like. Other status signals could also be used, if desired.

Some uses of the above components may be illustrative. For instance, finance companies may be more likely to finance auto purchase for individuals with less than
10 perfect credit because with monitoring device 10 installed, they will be able to assure proper asset protection and recovery of the asset with the currently costly locating and repossession processes. As another example, when an automobile reseller places the unit in a car, then on a daily or even hourly basis the reseller can assure the location of all of the vehicles each day. The dealer can also disable, secure, and set alarms on all
15 of their vehicles at the end of each day by a single computer command from their computer. This same process can activate all units with a single command the next morning and inform the dealer of problems with any car, such as low battery. The dealer can assign a range that their cars are not authorized to depart from, say a five-mile radius about the lot, and if any car does leave this limited area, the dealership can
20 be notified by system 100 along with law enforcement officials. The automobile can be tracked and when it is stopped, the automobile can be deactivated and the dealer notified of the location. When sold, the unit costs could be passed by agreement to the purchaser because the purchaser can get a lower finance rate by allowing the finance organization the right to send messages pertaining to payment status and to

deactivate the automobile if contract requirements are not being met. The finance company benefits because cost for collection agencies and wrecker services is reduced or eliminated. When the finance company is ready to pick up the deactivated auto, they will know the exact location. They can send someone to pick up the car, have it
5 activated, open the doors, and so forth. If a two-way pager is used, for instance as discussed hereinafter, the person to pick up the car can open the doors by sending a signal with the two-way pager. For the automobile owner, the options are very broad. The location of the vehicle is known, it can be tracked, the alarm can be activated, lights flashed, or when the car is stopped it can be activated and law enforcement can
10 be notified of the location. Turn by turn directions, road side assistance, and the like are available. When traveling across the country, monitoring unit 10 will automatically reacquire when it enters a new service area and system 100 will be notified of the location anywhere in the United States the unit is operated.

While system 100 can easily be programmed during initialization to activate
15 the outputs in a desired manner, monitoring unit 10 may also be programmed for operating desired outputs upon the occurrence of an event if desired as may typically occur when a large number of vehicles or other targets are desired to be wired in a similar way. For instance, it may be desired that upon air bag deployment, monitoring unit 10 automatically sends location information without the need for a
20 request to do so from system 100.

FIG. 5 provides a block diagram of the circuitry of monitoring unit 10 and FIG. 4 provides a flow diagram of software for monitoring unit 10. One reason for the very low cost of monitoring unit 10 is the use of microcontroller 50 as the means for operating monitoring unit 10. While microcontrollers require programming in a low-

level language that is closely related to the architecture of the chip, the cost of a microcontroller is much less than an embedded computer system that would allow programming in a high-level language useable with many different computers. Once programmed, the low cost of the microcontroller greatly reduces overall costs of

5 monitoring unit 10 and additional units may simply copy the same program into the microcontroller memory. In larger quantities, a microcontroller as used may cost in the range of \$2 each which is many times less expensive than even the lowest cost embedded computer systems. In a presently preferred embodiment, monitoring unit 10 uses a PIC16 microcontroller chip. The traditional definition of a microcontroller

10 is that of a processing engine with program ROM on the chip. The presently preferred embodiment microcontroller 50 has about 1000 bytes of ROM and also has a small amount of RAM which is less than 100 bytes. In this particular model, the chip does not have a port to read the program out so for security reasons, the program is protected. One of the functions provided by microcontroller 50 is to provide

15 information in the correct format to the pager port modem interface 52. To save costs, this approach is used so there is no need to change the interface hardware/software between the modem and pager but rather microcontroller 50 operates the modem to provide information in a format accepted by the pager and pager/modem interface hardware/software. Thus, this approach provides another significant development

20 cost savings.

The use of a pager with a pager modem is also much less expensive than the use of a cellular telephone with a modem. Therefore, equipment costs are greatly reduced. Furthermore, air time cost is also greatly reduced as pager air time costs much less than cellular telephone air time. Item 52 includes the pager/modem/port

connections as well as the interface between the pager and port that is preferably commercially obtained and left unmodified as discussed above so as to remain in compliance with FCC regulations without the need for retesting, modification, and so forth. Using these formats rather than attempting to modify this equipment is

5 considered a significant cost savings of the presently preferred embodiment although these items could be modified, if desired. In a presently preferred embodiment, pager port/modem 52 has inputs and outputs to form I/O port 54 built in, as has only recently become commercially available, thereby saving additional costs of providing the I/O port directly from microcontroller 50 as could also be provided. Moreover, by

10 eliminating input/output circuitry driven directly by microcontroller 50, component costs are reduced further. It is also possible to provide additional memory 55 which is preferably nonvolatile RAM such as an EEPROM to give greater flexibility of operation for monitoring unit 10. Memory 55 may be used to store events, for logging purposes, and generally provides much more flexibility of operation for monitoring

15 unit 10.

As presently preferred, I/O port 54 is operated indirectly by microcontroller 50 through pager port 52 rather than directly. It will be noted as discussed subsequently that events that occur, i.e., signals from the target, are transmitted according to the programming of microcontroller 50. As explained subsequently, this procedure

20 reduces air time costs. Preferably, at least two outputs of I/O port 54 have sufficient current for driving relays so as to control larger current devices. If required, driver circuits could be added as desired to effect more output control circuits. As discussed earlier, digital units with driver circuits could be added to the presently preferred embodiment of monitoring unit 10 to control sixteen outputs and/or receive sixteen

inputs. The outputs and inputs are electrical signals that are used with the target and are related to the type of target and may include a wide range of signals.

Microcontroller 50 presently handles on/off types of signals rather than analog signals so as to keep costs low, digitized analog signals could conceivably be used through
5 computer port 60.

Pager antenna 14 and GPS antenna 20 are connected to pager/modem 52 and GPS 56 as indicated. Global position sensor or GPS 56 preferably supports both standard and differential position information. GPS 56 communicates with microcontroller/CPU 50 and provides location information whenever requested. To
10 save power, microcontroller 50 can place GPS 56 in an idle position by means of GPS power control 58 until a GPS signal is requested by microcontroller 50, which in turn may have been requested from system 100 through pager/modem/pager port 52. Power control may be effected by a mosfet or other switching device as desired for low cost and reliable operation.

15 Computer port 60 is preferably an RS-232 port that provides the correct voltage levels, connectors, and so forth for compatibility with an external computer, such as external computer 38, discussed hereinbefore.

Typical operation of monitoring unit 10 may be described in terms of microcontroller 50 programming as per flow diagram 62. At the time monitoring unit
20 10 is powered on as indicated at 64, the unit begins to operate as per the flow diagram. Since the program information is stored in ROM in microcontroller 50 and any information saved in nonvolatile RAM memory 55, all memory information is readily available when power is turned on and is not lost with loss of power. Therefore, disconnection of the car battery for replacement or other reasons for loss of power

does not alter operation of monitoring unit 10 once power is restored.

If monitoring unit 10 has just been installed, then it is necessary to initialize the ports as indicated at 66. Initialization essentially requires notifying system 100 what each port is connected to, what the desired response is for any signal from the ports, and whatever requirements the client may have which information is typically stored in the database of system 100 as discussed subsequently. This may be accomplished with a form that is filled out and provided to system 100. For instance, the form may ask what each input line is connected to, e.g., line one to an air bag sensor, line two to a battery indicator, etc. Then a response for system 100 may be provided for each such event. Likewise the outputs are listed, e.g., output line one to alarm, output line two to door locks, output line three to an engine kill, etc. In this way, system 100 and/or the client can operate each of these items remotely. The client has the option to change or modify responses to signals as desired.

At item 68 in the flow diagram of FIG. 4, microcontroller 50 sends a command to GPS 56 to provide GPS location data that is indicative of the position at which monitoring unit 10 is located. Depending on the particular mode of operation and programming, this may also require turning GPS power on as indicated at 58 so that GPS 56 is no longer in an idle mode. Upon power up to monitoring unit 10 where power has been completely removed, it may take from one to several minutes to obtain a reading from GPS 56. If a GPS signal is not obtained within a certain time period, or if the GPS is removed (see discussion above on operating monitoring unit 10 without the GPS for stationary objects), then a timeout condition occurs and operation continues as indicated by flow diagram 62. A typical time period might be about three seconds but could vary depending on the type of GPS or as desired.

Assuming GPS 56 provides location data to microcontroller 50, then the location data is checked using a checksum method or other data checking means as indicated at 70. If the location data is determined to be valid, then the location data information is saved at 72 assuming it is desired to save the location data. Thus, a
5 flag may be set that determines whether or not to save the location data and may typically be set in response to a signal from system 100. The location data may be logged if desired into memory such as memory 55 if it is desired to save a series of location data. While system 100 can effect logging on any time schedule or in
10 response to events that may occur with respect to inputs, monitoring unit 10 may also be programmed to log data into memory 55 such as events, location data, output signals, and the like.

Upon completion of the above described data collection sequence, the GPS portion of the signal is completed until the next cycle of the program. At this time, microcontroller 50 checks as indicated at 74 to see if the pager (which is considered
15 part of pager port/modem indicated at 52) has been initialized. It is necessary to initialize the pager upon the first program cycle after installation of the unit. After the first program cycle, the necessary initialization information is stored in nonvolatile memory and a flag is set so that the program would skip this and go to the next step. Initialization occurs at step 76 and may include, for instance, determining that pin
20 numbers for the pager in port/pager/modem 52 and for monitoring unit 10 are established for setting up the pager network and setting forth where messages from each monitoring unit 10 or group of monitoring units 10 are stored. Thus, this step includes the steps that are typically required for the preferred two-way pager operation. As well, the inputs and outputs may be checked to insure they are

operational. External computer 38 may be used via computer port 60 to aid in set up or to change programming if desired. Once initialization is successfully accomplished, a flag is set to the effect the pager has been initialized and this process need not be repeated. If initialization fails for some reason, or is incomplete, then the
5 program proceeds to the end and loops back to start again.

Assuming the initialization flag is set, then microcontroller 50 checks to see if flags are set for new messages from system 100, and if so, then the messages are downloaded as indicated at 78. To save costs on air time, all the messages are preferably executed prior to uploading or transmitting at 80 so that all upload
10 messages can be sent at the same time. If there is a message from system 100, then it is downloaded and the message is deleted from the list or queue of messages if there is more than one message waiting. Assuming the message makes a valid request or one that is in line with initialization criteria as indicated 84, then the message is executed at 86. An example might be a message from system 100 to send location
15 data. In that case, at this time microcontroller would proceed according to programming to poll GPS 56 to obtain an update of the location. As another example, system 100 might send a message that has the effect of unlocking the doors of a vehicle. In this case, microcontroller 50 would contact pager port 52 and activate the appropriate output. System 100 would have the information as to which output to
20 activate and the message would specify that output. If the message requires an upload, then the upload flag is set as indicated at 88.

Assuming all downloads are complete, then as indicated at 80 a check is made as to whether the upload flag is set. The flag can be set in several ways. The upload flag may be set if any of the inputs have been activated. Programming could also

provide for setting the flag at a time interval. If one or more inputs such as an air bag deployment, alarm, high temperature, or other input occur, then the flag may be set. As well, an upload flag may have been set as discussed at 88. A check is made that the unit initialization is registered at 90 and then an upload or transmission as indicated at 92 is made. Thus, for an upload, microcontroller 50 would encode the upload message into a format that is acceptable by the modem/pager interface through a connection in the pager port 52. The pager of port 52 transmits the message according to pager network protocol with any standard checks to ensure accurate transmission. After transmission, the reason flag for that particular upload is then reset after transmission as indicated at 86. At this point in the program, the pager section of the program is complete as indicated at 96. A delay or wait state is implemented at 98 which is typically only a short duration.

As discussed above, microcontroller 50 uses a low level language for implementation and does not have sufficient memory or a compiler to allow it use of a high level language. By high level is meant a language that is transferrable between different types of computers such as FORTRAN, C, or the like. Low level languages, which may include machine language, are dependent upon the particular architecture of a particular processing system and so are not typically transferrable from one machine to another unless the machines are intentionally made to be compatible. Use of low level language is more time consuming for the initial programming, but because the same program can be used in many monitoring units 10, the hardware to process a low level language is less expensive, and the overall result is a very low per unit cost when sold in volume. Moreover, low level language often executes more quickly than higher level languages and memory is used much more efficiently.

Referring now to FIG. 2 and FIG. 3, system 100 is presented in two different ways so as to provide a more complete description thereof and to show more fully the various possible interconnections. In FIG. 2, a basic block diagram of components is disclosed.

5 Monitoring unit 10 has been described hereinbefore in some detail and it will be understood that system 100 may work with large numbers of such units that may be operating throughout the United States and, in fact, may be located anywhere worldwide. Each monitoring unit 10 communicates with one or more pager networks 102 by wireless transmission means. In the U.S., the F.C.C. assigns a frequency band
10 for this type of communication and pager network 102 acts to transmit and receive messages. Pin numbers are used to verify authorization, to determine with which unit 10 communication takes place, and where to store messages. It will be understood that a pager network will have an infrastructure that includes numerous different antennas in order to cover a wide area and may typically include most, if not all, of the
15 area of interest such as the U.S. or another country. Anywhere in the world a pager would work, then monitoring unit 10 can also communicate. System 100 may include more than one pager network and retains the necessary information to communicate with monitoring unit 10 through different regions and within different pager network systems.

20 A connection is provided between pager network 102 and server 104 that may include a direct connection or a connection over a network such as an Internet connection. It will be understood that one or more servers may be used for operation of system 100. Server 104 operates with database 106 which, in a presently preferred embodiment, is an Oracle™ database. In the database, the information for operation

of system 100 with each monitoring unit 10 is stored. For instance, for each particular monitoring unit 10, database 106 stores the relevant inputs and outputs, client specifications regarding inputs and outputs, client messages and types of messages in response to signals, and so forth. For instance, data in database 106 may be included to monitor location at a particular time interval, monitor whether the location goes outside of a defined area such as a car leaving an area of town, send a notification to the appropriate client by the client's desired communication means, and so forth. Database 106 may include a wide variety of information such as contact numbers, emergency numbers for different regions, and the like so as to be able to offer a wide array of possible types of communication including even partially non-automated communications such as notification to an operator to contact a client by telephone, radio, or the like. Automatic communications may include e-mail messages, pager messages, telephone messages, fax messages, and others including any automated means of communication.

In a preferred embodiment, database 106 also includes a table or list of messages to be sent and a table of incoming messages which are operated on. Once operated on, the messages may be saved for as long as the client desires to keep track of communications that have occurred. A client may send one command that affects all his targets. For instance, a car sales outlet might send a single message to all vehicles to lock the doors and turn on the burglar alarm.

To illustrate a typical operation, numerous different clients such as client 108 may log onto system 100 over the Internet, through a modem connection, or other connection. Client 108 does not need to have a computer and may simply call an operator by telephone, radio, two-way pager or other communication means. At any

rate, client 108 contacts system 106 to request information, in response to a message from system 100, to send a command to one or more monitoring units 10, or for other such reasons. For instance, assume client 106 has four vehicles that are being monitored and supplies the appropriate identification number. He may then wish to

5 know the whereabouts of each vehicle. This request may be received by network or Internet connection 110 of server 104. Server 104 contacts database 106, perhaps using an Internet connection or other connection, and database 106 places the message on a table of outgoing messages. In a presently preferred embodiment, a dedicated server program such as server program 112 controls all messaging between

10 transmitter/receiver network 102 and database 106. Therefore, server program 112 takes the message from the table of outgoing messages in database 106, and sends the message to transmitter 106 with the correct pin numbers for identification of the particular four monitoring units to be contacted. The message is then sent out and, due to the identification numbers, the appropriate four monitoring units 10 respond to

15 the request, as discussed above. Thus, the monitoring units 10 provide updated location information that is received by receiver/transmitter system 102. Server program 112 takes these messages from the pin data storage location and sends them to database 106 where they are placed in the table of incoming messages. The client has requested the results sent to him, so the information goes to server 110 and then to

20 client 108. Client 108 may view the information in different ways. For instance, in accord with the present invention, Client 108 may preferably use a program having a screen with a map such as shown in FIG. 6 whereupon one or more vehicles 114 may be shown on the particular street 116 within the map section 109 that is selected for viewing. The client may track the path of vehicles using different symbols and the

like as desired. The present invention provides a mapping system and program for tracking, labeling, and monitoring so that assets being sent by different types of transport vehicles such as ships, trains, trucks, and the like can be tracked and reference is made to U.S. Provisional Application No.60/119,378 filed February 9, 5 1999 and U.S. Provisional Application No. 60/125,658 filed March 22, 1999 wherein such programming is described in detail and was previously incorporated herein by reference.

System 100 may also be used for monitoring fixed assets such as for utility meter readings, home monitoring, and the like both in an active and passive role. In 10 fact, it may be more desirable to monitor a home by a radio link rather than by a telephone connection as the telephone connection is readily cut or otherwise disabled whereas a radio link is typically be more difficult to detect and disable especially if the antenna is hidden. System 100 also contemplates communication using, for instance, a two-way pager such as two-way pager 118. The pager communicates with server 15 104 through pager network 102 to thereby send a message to monitoring unit 10. As well, database 106 may be programmed notify two-way pager 102 in response to a message from monitoring unit 10. Thus, using a two-way pager it is possible to stand next to a vehicle and if monitoring unit 10 is appropriately wired, then opening the doors, starting the engine, etc., using a two-way pager.

20 High capacity clients as indicated at 120 may preferably have a direct connection to database 106. This would allow large clients to monitor, track, and so forth a large number of assets at high speeds. For instance, a utility company checking meters may need to check a large number of meters each day and would preferably have a high speed connection. The connection may be of different types

including local area networks, remote via modem connections, and so forth.

System 100 is also operable for communication with other types of transmission as may occur from cargo carriers of all types such as vessels or destinations with respective communication means 122, 124, and 126. Typical
5 examples might include offshore oil platforms that receive cargo, ships carrying cargo, supply ports and so forth. Communication may be derived with different systems such as through packet radio modems 128 or satellite communication transceiver 130. The system of the present invention can track cargo, print manifests, be used for ordering products, list suppliers, and display cargo location on a desired map. Thus,
10 the present system, apparatus, and methods may be used for a wide variety of tracking, monitoring, and logistics purposes.

The foregoing disclosure and description of the invention are illustrative and explanatory thereof, and it will be appreciated by those skilled in the art, that various changes may be made in the system integration and components as well as in the
15 details of the illustrated arrangements or combinations of features without departing from the spirit of the invention.

CLAIMS

What is claimed is:

1. A monitoring device for monitoring a target, comprising:
5 a microcontroller programmed for operating said monitoring device;
a pager operable for communicating with a pager network;
a pager modem for interfacing with said pager for communicating over said
pager network;
a global positioning sensor; and
10 an interface between said monitoring device and said target for communicating
signals relating to said target.
2. The monitoring device of Claim 1, further comprising:
a computer port for connecting said monitoring device to a computer to allow
15 communication between said computer and said pager network.
3. The monitoring device of Claim 2, further comprising:
said pager modem and said microcontroller being operable for sending email
messages over said pager network.
20
4. The monitoring device of Claim 1, wherein:
said pager is operable for sending and receiving signals over said pager
network.

5. The monitoring device of Claim 1, wherein said interface further comprising:

one or more inputs to said monitoring device from said target, and
one or more outputs from said monitoring device to said target.

5

6. The monitoring device of Claim 1, wherein said target is a vehicle and said interface communicates electrical signals relating to one or more elements of said vehicle.

10

7. The monitoring device of Claim 1, wherein:
said microcontroller is programmed in a low level language closely related to an architecture of said microcontroller.

15

8. The monitoring device of Claim 1, wherein:
said microcontroller is programmed to receive a message from said modem and execute one or more commands in response to said message.

20

9. The monitoring device of Claim 1, wherein:
said microcontroller has no port that allows access for reading programming of said microcontroller.

10. A monitoring system for monitoring a target, comprising:
a microcontroller programmable in a low level language closely related to an
architecture of said microcontroller;
a pager for transmitting and receiving pager signals;
5 a pager modem for interfacing with said pager;
a target interface between said monitoring device and said target for
communicating one or more target signals relating to said target; and
said microcontroller, said pager, said pager modem, and said target interface
being affixed to said target.

10

11. The monitoring system of Claim 10, further comprising:
a pager network operable for communication with a plurality of pagers, and
one or more computers having an Internet connection, said one or more
computers being operable for communicating over said Internet and through said
15 pager network to detect said one or more target signals.

12. The monitoring system of Claim 11, wherein:
said one or more computers being operable for sending a target control signal
through said Internet connection for controlling a feature of said target.

20

13. The monitoring system of Claim 10, further comprising:
a pager network operable for communication with a plurality of pagers,
a computer connection operable with said pager network, and
a database operable for storing definitions of each of said one or more target

signals for a plurality of targets.

14. The monitoring system of Claim 10, further comprising:
a global positioning sensor affixed to said target.

5

15. The monitoring system of Claim 14, wherein:
said microcontroller is programmed to collect location data from said global
positioning sensor, and send said location data through said pager modem.

10

16. The monitoring system of Claim 14, wherein:
a pager network operable for communication with a plurality of pagers,
one or more client computers, said one or more client computers being
operable for communicating through said pager network and said pager modem to
determine a location of said target.

15

17. The monitoring system of Claim 10, further comprising:
a pager network operable for communication with a plurality of pagers,
a server in communication with said pager network, and
one or more computers being operable for communicating over said server
20 through said pager network to detect said one or more target signals.

18. The monitoring system of Claim 10, further comprising:
a database for storing initialization information defining said one or more
target signals for each of a plurality of targets.

19. The monitoring system of Claim 10, further comprising:
a pager network operable for communication with a plurality of pagers, and
a two-way pager operable for communicating through said pager network and
with said pager modem to send a message to be operated on by said microcontroller.

5

20. A method for monitoring a target, comprising:
attaching a pager with an antenna to said target;
attaching an electrical interface to said target;
providing that one or more electrical signals may be received from said target
5 through said electrical interface;
providing for encoding of a message to a pager modem to form a modem
encoded message relating to said one or more electrical signals from said target;
controlling said electrical interface and said pager modem with a
microcontroller; and
10 providing for transmission of said modem encoded message through said
pager using said antenna.

21. The method of Claim 20, further comprising:
repeatedly checking said electrical interface for said one or more electrical
15 signals from said target.

22. The method of Claim 20, further comprising:
transmitting a message from a pager network to said pager,
receiving said message through said pager modem, and
20 executing a command responsive to said message.

23. The method of Claim 20, further comprising:
determining a global position,
encoding a message to a pager modem to form a global position message

based on said global position, and

transmitting said global position message through said pager using said antenna.

5 24. The method of Claim 23, further comprising:

receiving said global position message through a pager network, and

saving said global position message in a database.

25. The method of Claim 24, further comprising:

10 providing for remote access to said database.

26. The method of Claim 25, further comprising:

providing access to said database over an Internet connection.

15 27. The method of Claim 20, wherein:

said target is a vehicle, and said one or more electrical signals relate to said vehicle.

28. The method of Claim 20, wherein:

20 said target is a structure affixed to the Earth so as to be non-moveable.

29. The method of Claim 23, further comprising:

affixing a module with said pager, said antenna, and said microcontroller to said target where said target is a vehicle.

30. The method of Claim 29, further comprising:
remotely operating said module for enforcing a loan related to said vehicle.

31. The method of Claim 29, further comprising:
5 remotely operating said module for determining that said vehicle stays within a
selectable region.

32. A monitoring system for monitoring a plurality of targets on behalf of a plurality of clients, each of said clients being associated with one or more of said plurality of targets, comprising:

5 a computer network server operable for communicating with a plurality of client computers;

a database operable for storing information relating to each of said plurality of targets;

10 a pager network system operable for communicating wirelessly with a plurality of pagers, said computer network server being in communication with said pager network system; and

a plurality of wireless communication units for each of said plurality of targets, each of said plurality of wireless communication units being operable for communication with said wireless network, each of said plurality of wireless communication units including a global position sensor to provide location information for each of said plurality of targets, each of said plurality of client computers being operable for sending a message to request said location information relating to said one or more of said plurality of targets with which said client is associated.

20 33. The monitoring system of Claim 32, wherein:

said computer network server is operable for communicating with said plurality of client computers over an Internet connection.

34. The monitoring system of Claim 33, further comprising:

said plurality of client computers being operable for producing a map showing thereon a geographic picture of one or more of said plurality of targets.

35. The monitoring system of Claim 33, wherein:

5 each of said plurality of client computers being operable for selectively communicating with all or with specific of said one or more of said plurality of targets with which said client is associated.

36. The monitoring system of Claim 32, further comprising:

10 said database being operable for storing information for each of said plurality of targets that includes definitions of inputs and outputs for a respective interface between each of said plurality of targets each corresponding wireless communication unit.

15 37. The monitoring system of Claim 32, :

said database being operable for containing a list of ingoing and outgoing messages.

38. The monitoring system of Claim 32, further comprising:

20 said plurality of wireless communication units including a pager receiver/transmitter and a pager modem for encoding said location information.

39. The monitoring system of Claim 32, further comprising:

at least a portion of said plurality of targets being a plurality of transport

vessels,

a wireless network system for communicating with said plurality of transport vessels, and

said database being operable for storing vessel location information.

5

40. The monitoring system of Claim 32, further comprising:

a two-way pager operable for contacting one or more of said plurality of wireless communication units through said pager network.

10

41. The monitoring system of Claim 32, further comprising:

a target interface for each of said plurality of wireless communication units for communicating electrical signals to said wireless communication unit related to said target.

15

42. The monitoring system of Claim 41, further comprising:

a microcontroller for operating said wireless communication unit.

43. The monitoring system of Claim 41, further comprising:

said plurality of client computers are each operable for communicating with said computer network server relating to said electrical signals for said one or more of said plurality of targets with which said client is associated.

44. The monitoring system of Claim 43, further comprising:

at least a portion of said plurality of targets are vehicles,

each vehicle having an electrical system connected to said target interface,
said plurality of client computers being operable for sending an electrical
signal to said electrical system of said vehicle through said target interface for said
one or more of said plurality of targets with which said client is associated.

5

45. The monitoring system of Claim 43, further comprising:
at least a portion of said plurality of targets are vehicles,
each vehicle having an electrical system connected to said target interface,
said plurality of client computers being operable for detecting an electrical
10 signal from said vehicle through said target interface, said wireless network system,
and said computer network server in accordance with a description for each said target
interface stored within said database.

46. A monitoring device for monitoring a target, comprising:
a microcontroller programmable in a low level language closely related to an
architecture of said microcontroller;
a target interface between said monitoring device and said target for
5 communicating one or more electrical target signals relating to said target;
a memory controllable by said microcontroller for storing data;
a global positioning sensor for producing target location information; and
said microcontroller, said memory, said global positioning sensor, and said
target interface being affixed to said target.

10

47. The monitoring device of Claim 46, wherein:
said microcontroller is programmable for storing a plurality of records in said
memory relating to said target location information.

15 48. The monitoring device of Claim 47, further comprising:
a computer for receiving said plurality of records and producing a map
showing a path of movement of said target with respect to a time period.

49. The monitoring device of Claim 48, further comprising:
20 said computer being operable for comparing said path of movement of said
target with a second path of movement for a second target.

50. The monitoring device of Claim 46, further comprising:
a pager, and

a pager modem, said microcontroller being programmable to operate said pager modem for transmitting said location information through said pager.

51. A monitoring system operable for monitoring a plurality of targets on behalf of a plurality of users, each of said users being associated with one or more of said plurality of targets, comprising:

a computer network server operable for communicating with a plurality of
5 client computers;

a database operable for storing information relating to each of said plurality of targets;

a plurality of wireless communication units, a respective of said plurality of wireless communication units associated with each of said plurality of targets, each of
10 said plurality of wireless communication units including a global position sensor to provide location information for each of said plurality of targets;

a wireless network system operable for communicating wirelessly with a plurality of wireless communication units, said computer network server being in communication with said pager network system, each of said plurality of wireless
15 communication units being operable for communication with said wireless network, each of said plurality of client computers being operable for requesting said computer network server to provide location information relating to said one or more of said plurality of targets with which said client is associated.

20 52. The monitoring system of Claim 51, wherein:

said computer network server is operable for communicating with said plurality of client computers through a world-wide computer network.

53. The monitoring system of Claim 51, further comprising:

said plurality of client computers being operable for producing a map showing thereon a geographic picture of one or more of said plurality of targets.

54. The monitoring system of Claim 51, wherein said plurality of wireless
5 communication units further comprise:

a plurality of inputs for receiving status information related to a respective target.

55. The monitoring system of Claim 54, wherein said plurality of wireless
10 communication units further comprise:

a plurality of outputs for supplying signals to said respective target.

56. The monitoring system of Claim 55, wherein said plurality of wireless
communication units further comprise:

15 transmitter and receiver electronics for two-way communication with said wireless network system related to said plurality of inputs and said plurality of outputs and said location information.

57. The monitoring system of Claim 56, wherein said plurality of wireless
20 communication units further comprise:

programmable electronics related to said plurality of inputs and said plurality of outputs.

58. The monitoring system of Claim 56, wherein:

each of said plurality of client computers being operable for selectively

communicating with all or with specific of said one or more of said plurality of targets with which said client is associated.

59. The monitoring system of Claim 56, further comprising:

5 said database being operable for storing information for each of said plurality of targets that includes definitions of inputs and outputs for a respective interface between each of said plurality of targets and each corresponding wireless communication unit.

10 60. The monitoring system of Claim 56, further comprising:

said database being operable for containing a list of ingoing and outgoing messages.

61. The monitoring system of Claim 51, further comprising:

15 said plurality of wireless communication units including a receiver/transmitter, a modem, and electronics for encoding said location information for said modem.

62. The monitoring system of Claim 51, further comprising:

20 at least a portion of said plurality of targets being a plurality of transport vessels,

said database being operable for storing vessel location information.

63. The monitoring system of Claim 51, further comprising:

a target interface for each of said plurality of wireless communication units for communicating electrical signals to said wireless communication unit related to said target.

5 64. The monitoring system of Claim 63, further comprising:
said plurality of client computers are each operable for communicating with said computer network server relating to said electrical signals for said one or more of said plurality of targets with which said client is associated.

10 65. The monitoring system of Claim 51, further comprising:
a microcontroller for operating said wireless communication unit.

 66. The monitoring system of Claim 51, further comprising:
at least a portion of said plurality of targets are vehicles,
15 each vehicle having an electrical system connected to said target interface,
said plurality of client computers being operable for sending an electrical signal to said electrical system of said vehicle through said target interface for said one or more of said plurality of targets with which said client is associated.

20 67. The monitoring system of Claim 51, further comprising:
at least a portion of said plurality of targets are vehicles,
each vehicle having an electrical system connected to said target interface,
said plurality of client computers being operable for detecting an electrical signal from said vehicle through said target interface, said wireless network system,

and said computer network server in accordance with a description for each said target interface stored within said database.

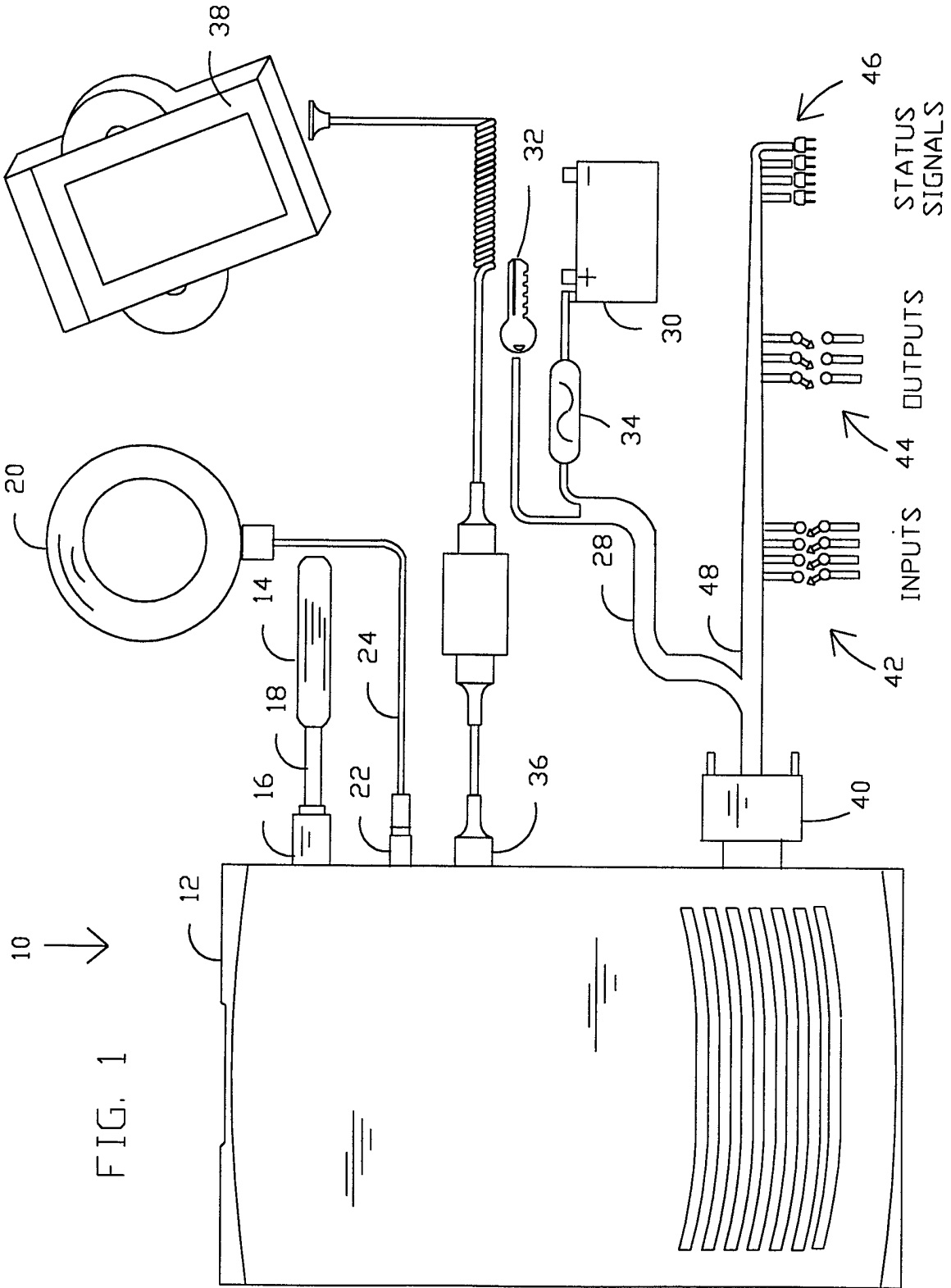
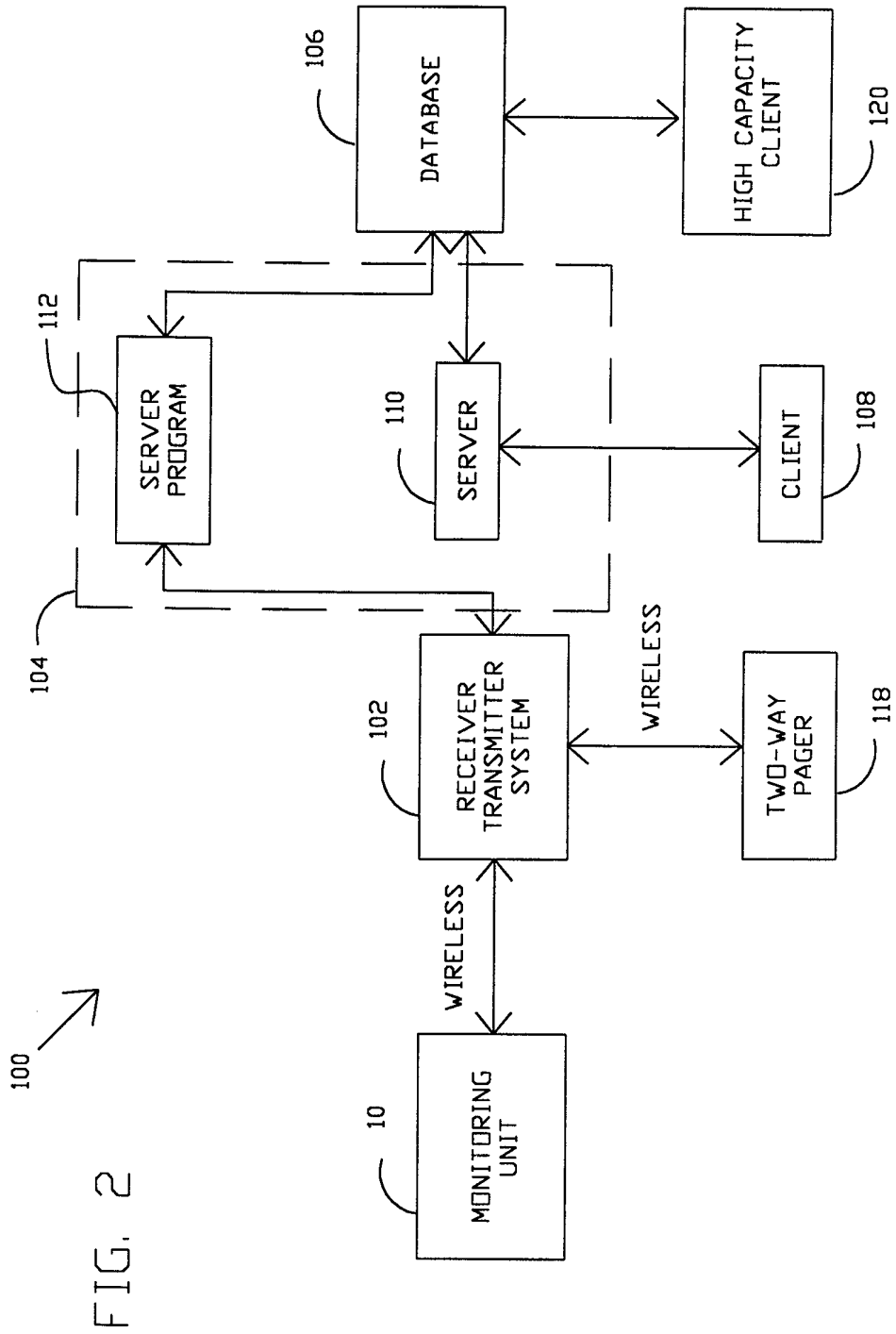

FIG. 1



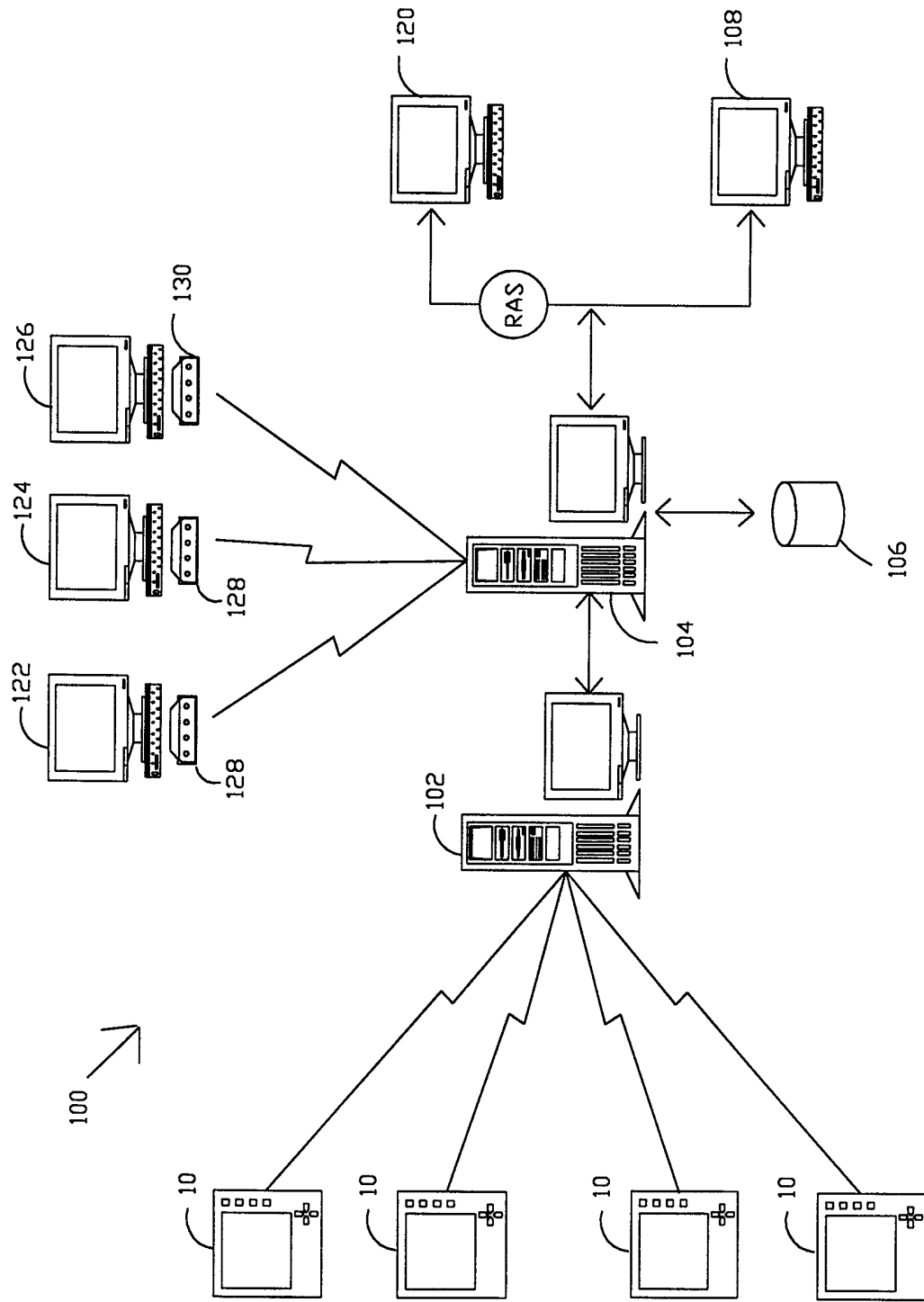
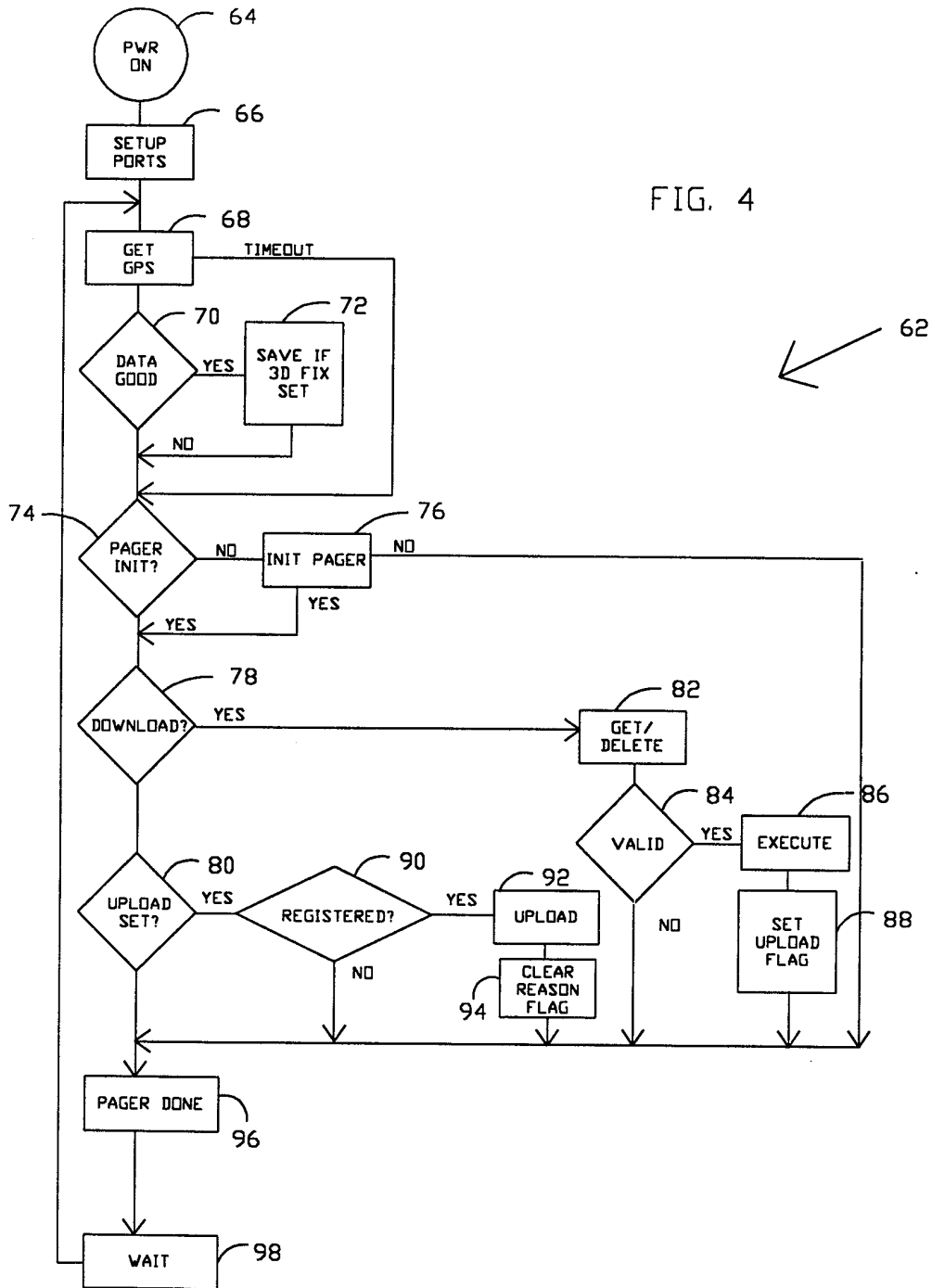

FIG. 3

FIG. 4



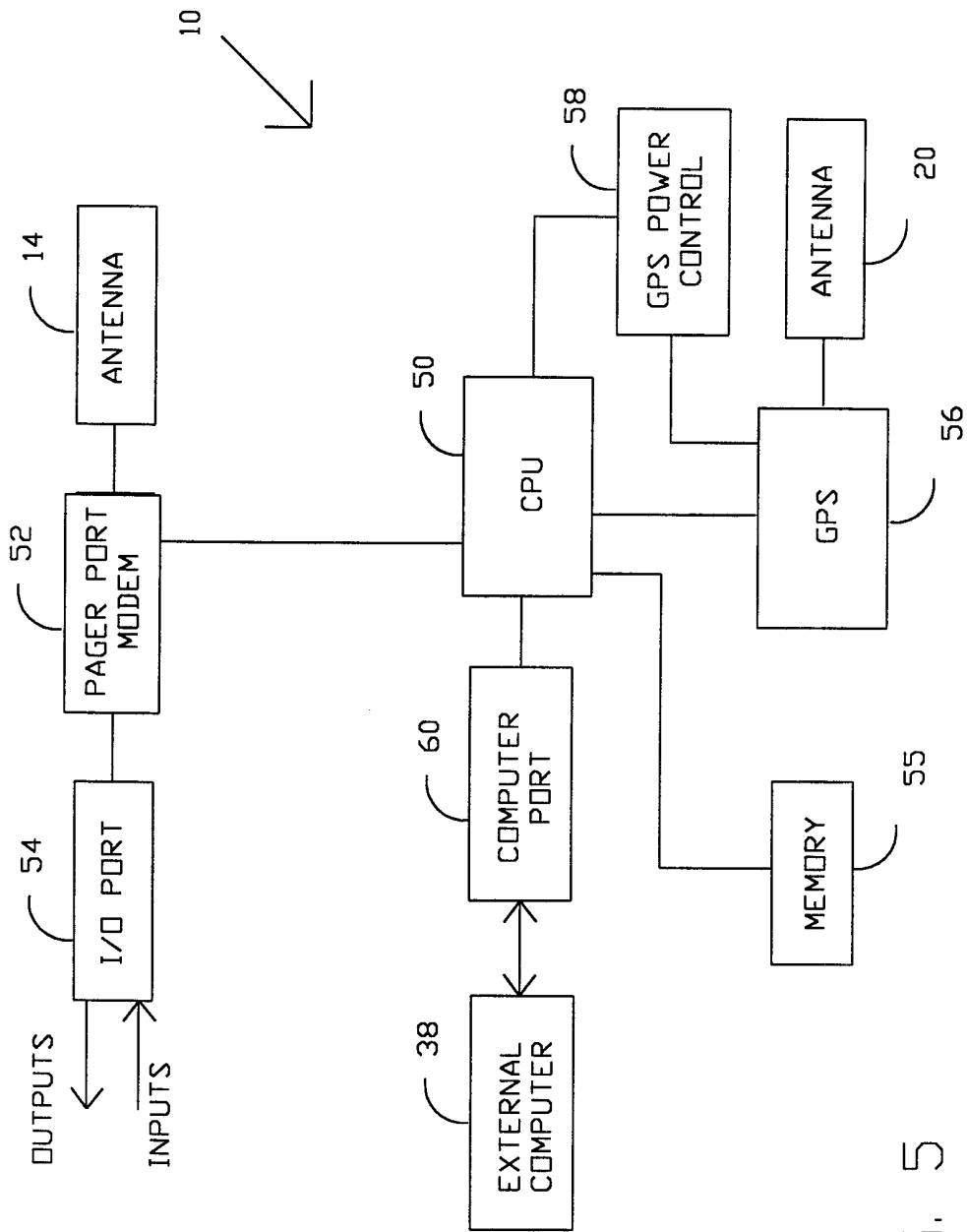

FIG. 5

