



US00D573195S

(12) **United States Design Patent**  
**Rushe et al.**

(10) **Patent No.:** **US D573,195 S**  
(45) **Date of Patent:** **\*\* Jul. 15, 2008**

(54) **CORRECTION ROLLER**

(75) Inventors: **Peter Rushe**, Duesseldorf (DE); **Kai Ruthe-Steinsiek**, Duesseldorf (DE)

(73) Assignee: **Henkel KGaA**, Dusseldorf (DE)

(\*\*) Term: **14 Years**

(21) Appl. No.: **29/293,934**

(22) Filed: **Dec. 18, 2007**

(30) **Foreign Application Priority Data**

Jun. 19, 2007 (EM) ..... 000742515

(51) **LOC (8) Cl.** ..... **19-02**

(52) **U.S. Cl.** ..... **D19/69**

(58) **Field of Classification Search** ..... D19/66,  
D19/67, 68, 69, 70; 156/523, 257, 540, 577;  
206/411; 225/6, 25, 39, 77; 242/588, 588.1,  
242/588.2, 588.3, 588.6, 5

See application file for complete search history.

(56) **References Cited**

**U.S. PATENT DOCUMENTS**

D378,532 S *	3/1997	Suzuki	.....	D19/69
D416,288 S *	11/1999	Kuehn	.....	D19/69
D452,273 S *	12/2001	Blom et al.	.....	D19/46
D467,617 S *	12/2002	Soetewey	.....	D19/69
D475,747 S *	6/2003	Ono	.....	D19/69
D491,986 S *	6/2004	Bain	.....	D19/69
D492,352 S *	6/2004	Lammers et al.	.....	D19/68
D501,032 S *	1/2005	Kah	.....	D19/69
D506,508 S *	6/2005	Shimizu et al.	.....	D19/69
D532,457 S *	11/2006	Chen	.....	D19/69
D542,845 S *	5/2007	Suzuki	.....	D19/69

\* cited by examiner

*Primary Examiner*—Cathron Brooks  
*Assistant Examiner*—Austin Murphy  
(74) *Attorney, Agent, or Firm*—Steven C. Bauman; James E. Piotrowski

(57) **CLAIM**

The ornamental design for a correction roller, as shown and described.

**DESCRIPTION**

FIG. 1 is a front left perspective view of the correction roller (shown with the front portion extended and the tip in broken lines) according to the new design;

FIG. 2 is a front elevation view thereof;

FIG. 3 is a rear elevation view thereof;

FIG. 4 is a top plan view thereof;

FIG. 5 is a bottom plan view thereof;

FIG. 6 is a left elevation view thereof;

FIG. 7 is a right elevation view thereof;

FIG. 8 is a front left perspective view of the correction roller (shown with the front portion in an alternate folded position) according to the new design;

FIG. 9 is a front elevation view thereof;

FIG. 10 is a rear elevation view thereof;

FIG. 11 is a top plan view thereof;

FIG. 12 is a bottom plan view thereof (shown with the tip in broken lines);

FIG. 13 is a left elevation view thereof; and,

FIG. 14 is a right elevation view thereof.

The broken lines showing the tip of the correction roller serve the purpose of illustrative example and form no part of the claimed design.

**1 Claim, 6 Drawing Sheets**

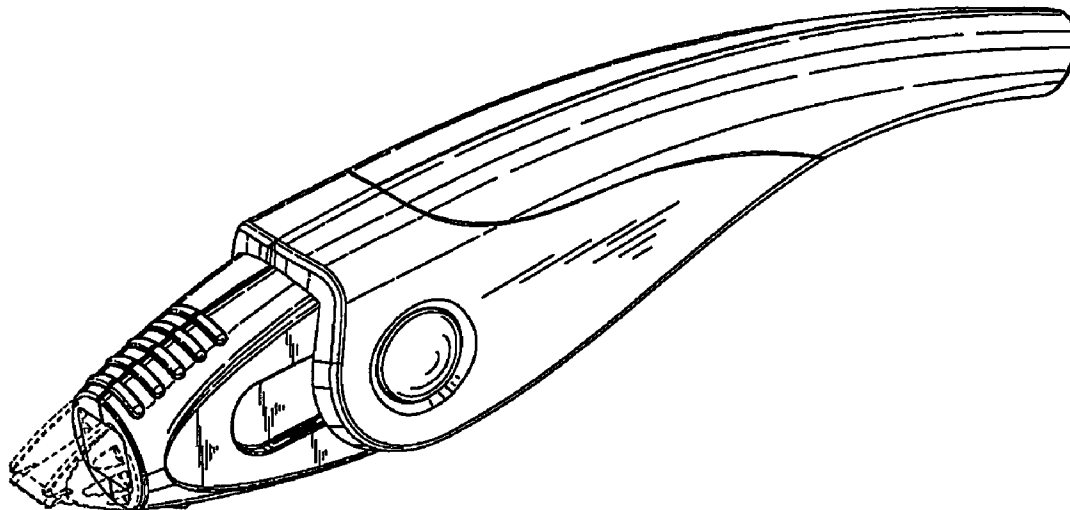

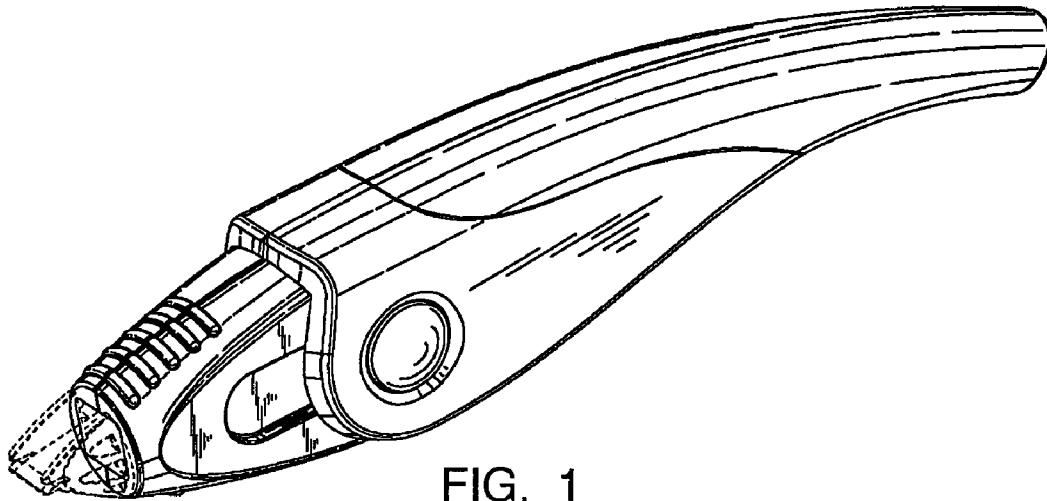

FIG. 1

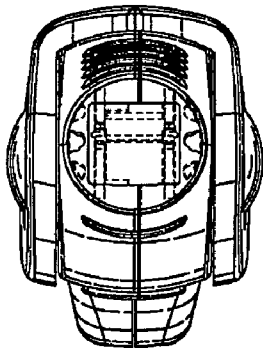

FIG. 2

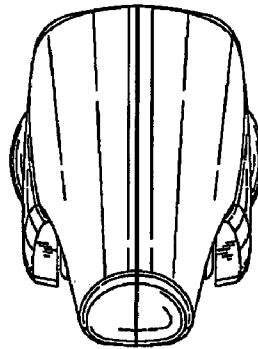

FIG. 3

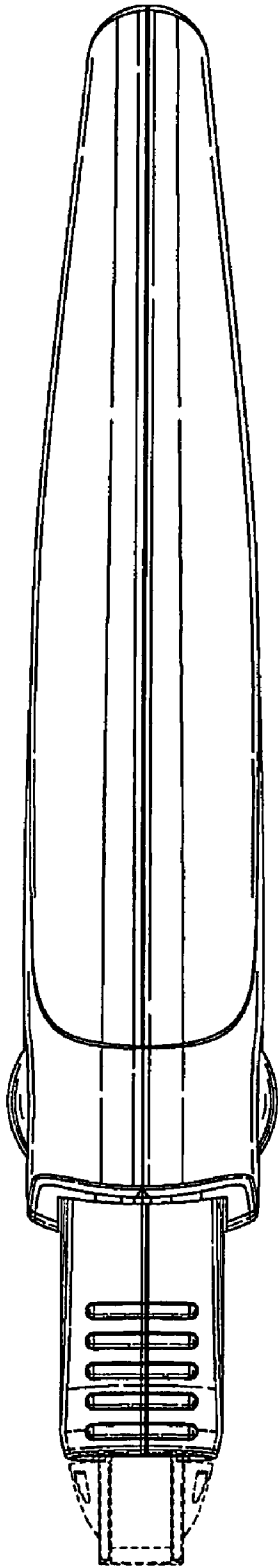

FIG. 4

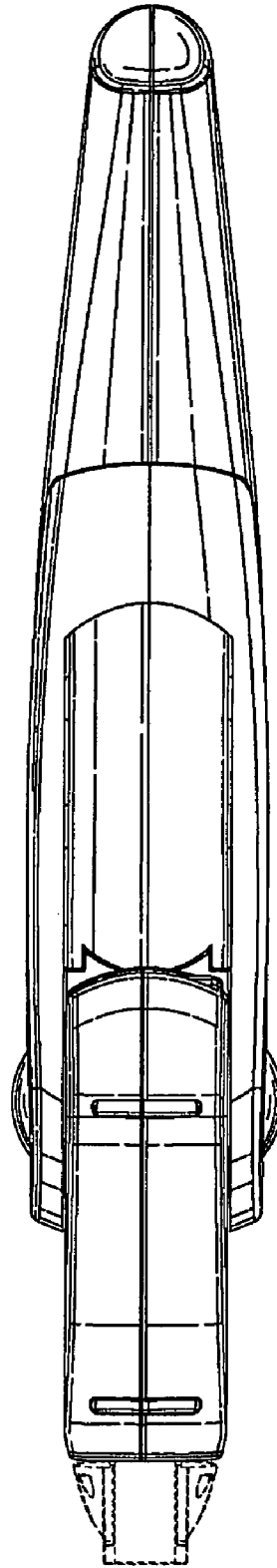

FIG. 5



FIG. 6



FIG. 7

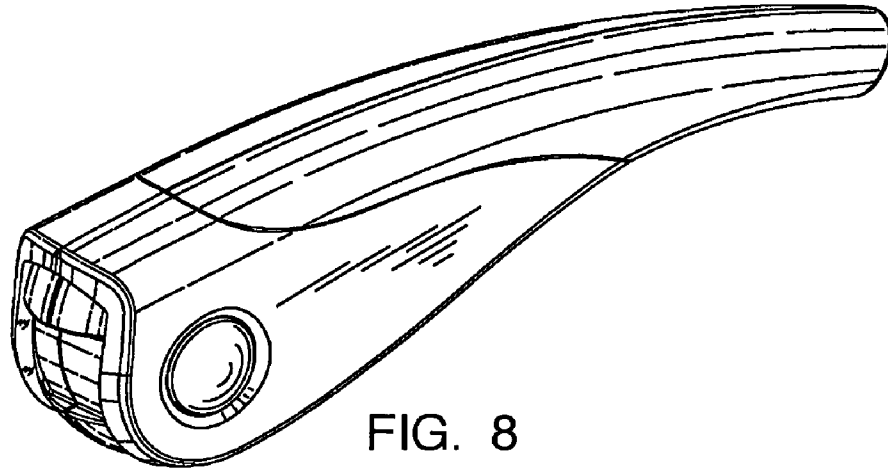

FIG. 8

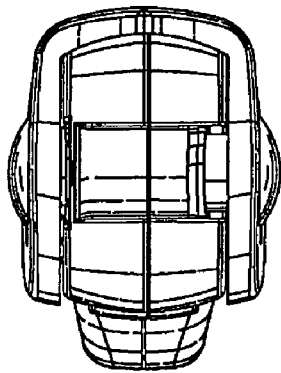

FIG. 9

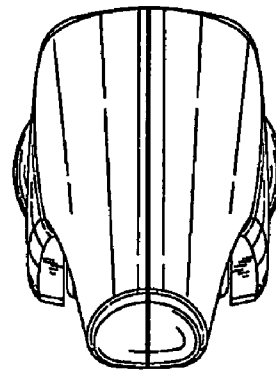

FIG. 10

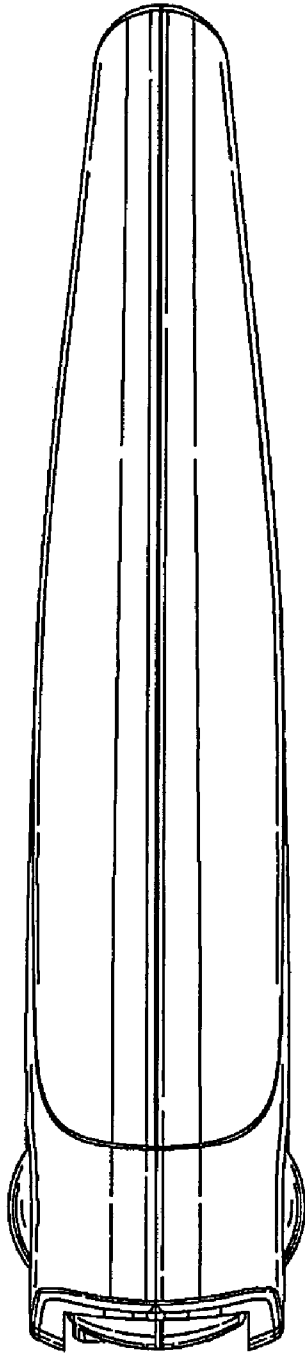

FIG. 11

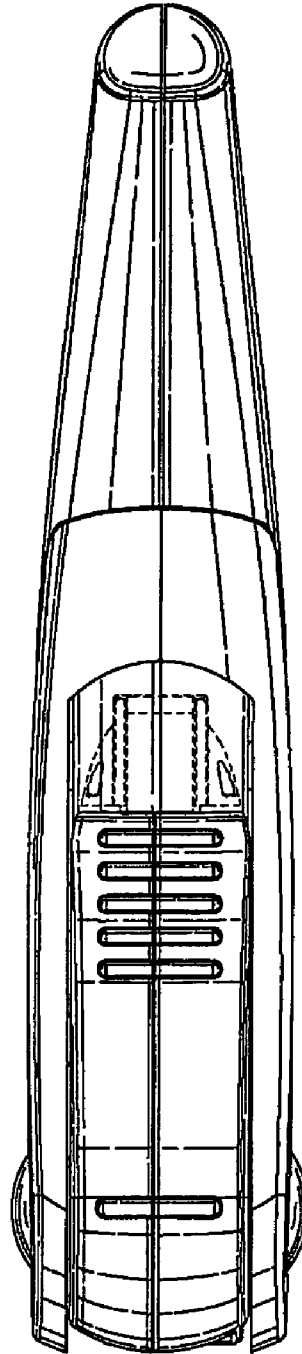

FIG. 12

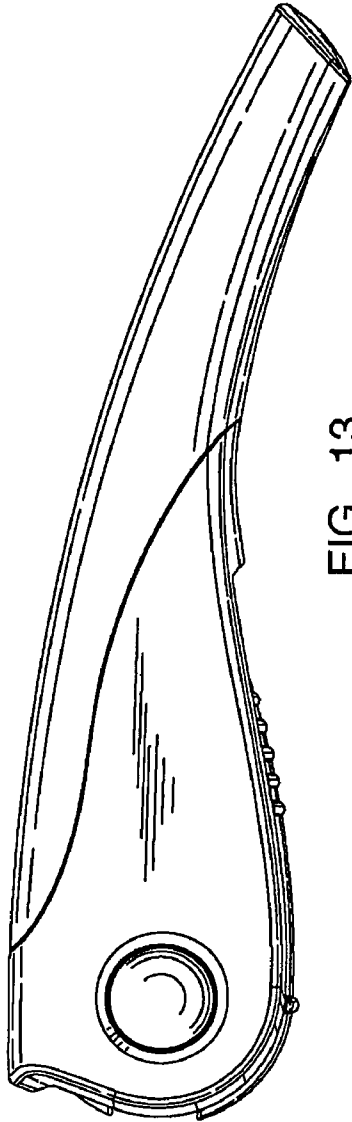

FIG. 13

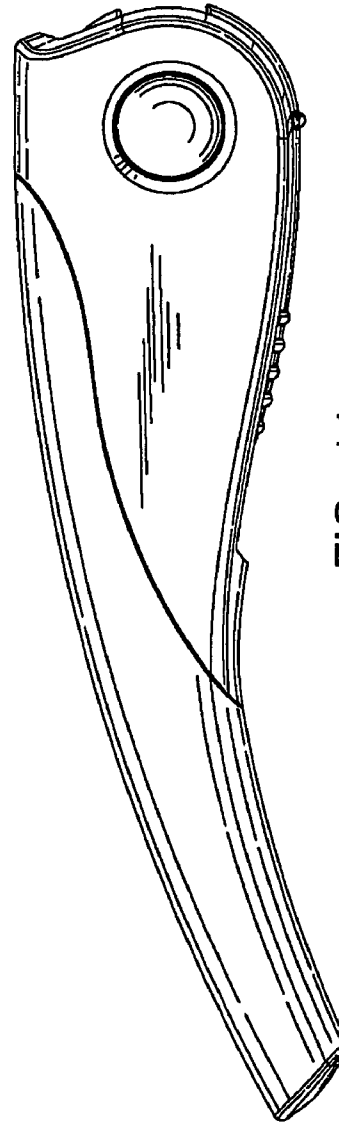

FIG. 14