

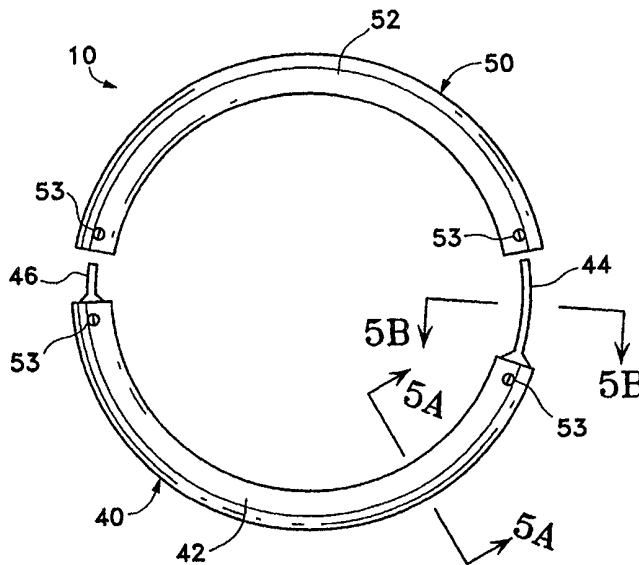

INTERNATIONAL APPLICATION PUBLISHED UNDER THE PATENT COOPERATION TREATY (PCT)

<p>(51) International Patent Classification ⁷ : A61F 2/14</p>	<p>A1</p>	<p>(11) International Publication Number: WO 00/07525 (43) International Publication Date: 17 February 2000 (17.02.00)</p>
<p>(21) International Application Number: PCT/US99/17762 (22) International Filing Date: 5 August 1999 (05.08.99) (30) Priority Data: 09/129,600 5 August 1998 (05.08.98) US (71) Applicant (for all designated States except US): KERAVISION, INC. [US/US]; 48630 Millmont Drive, Fremont, CA 94538-7353 (US). (72) Inventor; and (75) Inventor/Applicant (for US only): SILVESTRINI, Thomas, A. [US/US]; 1701 Las Trampas Road, Alamo, CA 94507 (US). (74) Agents: BECKING, Frank, P. et al.; Morrison & Foerster LLP, 755 Page Mill Road, Palo Alto, CA 94304-1018 (US).</p>		<p>(81) Designated States: AE, AL, AM, AT, AU, AZ, BA, BB, BG, BR, BY, CA, CH, CN, CR, CU, CZ, DE, DK, EE, ES, FI, GB, GE, GH, GM, HR, HU, ID, IL, IN, IS, JP, KE, KG, KP, KR, KZ, LC, LK, LR, LS, LT, LU, LV, MD, MG, MK, MN, MW, MX, NO, NZ, PL, PT, RO, RU, SD, SE, SG, SI, SK, SL, TJ, TM, TR, TT, UA, UG, US, UZ, VN, YU, ZA, ZW, ARIPO patent (GH, GM, KE, LS, MW, SD, SL, SZ, UG, ZW), Eurasian patent (AM, AZ, BY, KG, KZ, MD, RU, TJ, TM), European patent (AT, BE, CH, CY, DE, DK, ES, FI, FR, GB, GR, IE, IT, LU, MC, NL, PT, SE), OAPI patent (BF, BJ, CF, CG, CI, CM, GA, GN, GW, ML, MR, NE, SN, TD, TG).</p> <p>Published <i>With international search report.</i> <i>Before the expiration of the time limit for amending the claims and to be republished in the event of the receipt of amendments.</i></p>

(54) Title: CORNEAL IMPLANT WITH MIGRATION PREVENTER



(57) Abstract

The present invention is directed to a corneal implant comprising one or more physiologically compatible inserts adapted for implantation within an interlamellar channel made within the cornea of a mammalian eye. Each insert comprises a main section providing substantially all of the adjustment to the corneal curvature to thereby correct vision abnormalities. At least one of the inserts further comprises one or two migration preventing extension sections, each coupled to an end of the main section. After implantation within the intracorneal channel, the extension section extends from an end of the main section and is disposed near or abuts either the main section of another insert or an end of the intracorneal channel. The extension section serves as a stop to reduce or prevent migration of the one or more inserts after implantation within the intracorneal channel.

FOR THE PURPOSES OF INFORMATION ONLY

Codes used to identify States party to the PCT on the front pages of pamphlets publishing international applications under the PCT.

AL	Albania	ES	Spain	LS	Lesotho	SI	Slovenia
AM	Armenia	FI	Finland	LT	Lithuania	SK	Slovakia
AT	Austria	FR	France	LU	Luxembourg	SN	Senegal
AU	Australia	GA	Gabon	LV	Latvia	SZ	Swaziland
AZ	Azerbaijan	GB	United Kingdom	MC	Monaco	TD	Chad
BA	Bosnia and Herzegovina	GE	Georgia	MD	Republic of Moldova	TG	Togo
BB	Barbados	GH	Ghana	MG	Madagascar	TJ	Tajikistan
BE	Belgium	GN	Guinea	MK	The former Yugoslav Republic of Macedonia	TM	Turkmenistan
BF	Burkina Faso	GR	Greece			TR	Turkey
BG	Bulgaria	HU	Hungary	ML	Mali	TT	Trinidad and Tobago
BJ	Benin	IE	Ireland	MN	Mongolia	UA	Ukraine
BR	Brazil	IL	Israel	MR	Mauritania	UG	Uganda
BY	Belarus	IS	Iceland	MW	Malawi	US	United States of America
CA	Canada	IT	Italy	MX	Mexico	UZ	Uzbekistan
CF	Central African Republic	JP	Japan	NE	Niger	VN	Viet Nam
CG	Congo	KE	Kenya	NL	Netherlands	YU	Yugoslavia
CH	Switzerland	KG	Kyrgyzstan	NO	Norway	ZW	Zimbabwe
CI	Côte d'Ivoire	KP	Democratic People's Republic of Korea	NZ	New Zealand		
CM	Cameroon			PL	Poland		
CN	China	KR	Republic of Korea	PT	Portugal		
CU	Cuba	KZ	Kazakistan	RO	Romania		
CZ	Czech Republic	LC	Saint Lucia	RU	Russian Federation		
DE	Germany	LI	Liechtenstein	SD	Sudan		
DK	Denmark	LK	Sri Lanka	SE	Sweden		
EE	Estonia	LR	Liberia	SG	Singapore		

CORNEAL IMPLANT WITH MIGRATION PREVENTER

FIELD OF THE INVENTION

5 The present invention relates to corneal implants generally. More specifically, the present invention relates to corneal implants to effect refractive correction of an eye.

BACKGROUND OF THE INVENTION

10 Anomalies in the overall shape of the eye can cause visual disorders. Hyperopia ("farsightedness") occurs when the front-to-back distance in the eyeball is too short. In such a case, parallel rays originating greater than 20 feet from the eye focus behind the retina. In contrast, when the front-to-back distance of eyeball is too long, myopia ("nearsightedness") occurs and the focus of parallel rays entering the eye occurs in front of the retina. Astigmatism is a condition which occurs when the parallel rays of light do not focus to a single point within the eye, but rather have a variable focus due to the fact that the cornea refracts light in a different meridian at different distances. Some degree of astigmatism is normal, but where it is pronounced, the astigmatism should be corrected.

15 Hyperopia, myopia, and astigmatism are usually corrected by glasses or contact lenses. Surgical methods for the correction of such disorders are known. Such methods include radial keratotomy (see, *e.g.*, U.S. Patents Nos. 4,815,463 and 4,688,570) and laser corneal ablation (see, *e.g.*, U.S. Patent No. 4,941,093).

20 Another method for correcting such disorders is by implanting a biocompatible material into a the cornea, such as into a channel formed between stromal layers of the cornea to change the curvature of the cornea. The material may be in the form of, for example, intrastromal corneal ring segments. For example, one or more segments of a ring may be implanted at the corneal periphery. In addition, each of International Pub. Nos. WO 25 95/03747, entitled "Segmented Pliable Intrastromal Corneal Insert", corresponding to U.S. Ser. No. 08/101,440, and WO 95/03755, entitled "Segmented Preformed Intrastromal Corneal Insert", corresponding to U.S. Ser. No. 08/101,438 disclose implanting one or more segments of rings into a circumferential interlamellar channel made within the cornea.

30 U.S. Pat. No. 5,733,334 to Lee entitled "Method and Apparatus for Adjusting Corneal Curvature" discloses adjusting corneal curvature by implanting in the cornea an adjustable split ring formed of an elastic hollow shell. The ring is filled with a

predetermined amount of biocompatible material to alter the thickness or diameter of the ring to thereby adjust the corneal curvature. Further adjustment of the ring may be made post-operatively after implantation by select removal of the biocompatible filler material.

5 A minimally invasive incision is used both for producing the channel and for inserting the implant. One example of a method to insert a segment into the intrastromal portion of the cornea is described. The first step is to cut a very small incision in the patient's eye. The incision penetrates into the cornea a distance of approximately 2/3 of the thickness of the cornea, i.e. the incision cuts through some but not of the corneal stroma layers or lamellae. Dissector blades may then inserted into the small incision to separate
10 the lamellae and form channels when the dissector blades are rotated. After the segment is implanted, the small incision may then be sutured.

However, when one or more segments are inserted into a channel having an arc angle or arc length greater than the total arc angle of the segments, gaps unfilled by the segments may result between the segments and/or between a segment and an end of the
15 channel. One or more of the segment may migrate toward an adjacent segment or toward an end of the channel. Such migration may be undesirable as it may affect the change in the corneal curvature. Furthermore, one or more of the segments may tend to migrate toward the location of the incision made through the corneal surface. Migration of a segment to a location directly under the incision may be especially undesirable as such migration may
20 hinder the flow of nutrients through the interlamellar layers of the cornea and thereby hinder wound healing at the incision.

Where two segments are implanted within a single intracorneal channel, the channel may be formed by making an initial incision through the corneal surface and then forming two portions of the channel extending in opposite circumferential directions from the
25 incision, as described in International Pub. No. WO 95/18569, entitled "System for Inserting Material Into Corneal Stroma", corresponding to U.S. Ser. No. 08/178,577. One segment is inserted into one portion of the channel which extends in one direction from the incision. Another segment is inserted into the other portion of the channel extending in the opposite direction from the incision. Additional segments may also be inserted into either
30 or both portions of the channel.

When a segment is inserted into the channel, the layers defining the interlamellar channel are separated by the segment where the segment is disposed as well as in a

transition region extending beyond each end of the segment. In the transition region beyond each end of the segment, the layers do not yet converge and a space unfilled by the segment is thereby defined, hereinafter an "unfilled space". Beyond the transition region, the layers once again converge.

5 With two or more segments, it may be desirable to dispose the segments within the channel with a distance between the segments. The two segments may be sufficiently distanced apart within the channel such that the transition regions of the two segments do not overlap and thus the lamellar layers converge between the two segments. The convergence of the lamellar layers thus forms two discontinuous unfilled spaces between
10 the two segments. The convergence of the lamellar layers prevents or reduces migration of one or both of the segments toward the other segment.

 If the two segments are not sufficiently distanced apart within the channel, the transition regions of the two segment overlap and thus the lamellar layers of the channel do not converge between the segments. The lack of convergence results in a single continuous
15 unfilled space between the two segments. Because of the single continuous unfilled space between the segments, there may be a tendency for one or both of the segments to migrate toward the other segment. As described above, such migration may be undesirable as it may affect the change in the corneal curvature and, if one of the segments migrates to a location directly under the incision, may also hinder wound healing.

20 Another method of correcting vision is disclosed in U.S. Pat. No. 5,909,955 to Simon. Simon discloses gel injection adjustable keratoplasty by interlamellar injection of a gel at the corneal periphery. Simon discloses injecting a gel into an intracorneal channel which conforms to the channel shape and then hardens or solidifies. The hardened gel of Simon may also suffer from the above-described migration problems. In particular, after
25 the gel has hardened, unfilled spaces are defined in the transition region extending beyond each end of the hardened gel. The hardened gel may similarly migrate toward, for example, a location under the incision.

 Thus, there is a need in the art for a corneal implant which, after implantation in the cornea, minimizes or prevents migration thereof within the intracorneal channel.

30

SUMMARY OF THE INVENTION

The present invention is directed to a corneal implant comprising one or more intrastromal corneal inserts adapted for implantation within an interlamellar channel made within the cornea of a mammalian eye, wherein at least one of the inserts has migration preventer to reduce or prevent migration of the insert after implantation within the channel. The insert, including migration preventer, subtends at least a portion of a ring, or "arc", encircling the anterior cornea outside of the cornea's field of view but within the cornea's frontal diameter. The inserts may also be used in multiples such that the inserts, including migration preventer, form a partial or complete ring and/or form constructs of varying thickness.

The one or more physiologically compatible inserts each comprises a main section providing most or all of the adjustment to the corneal curvature to thereby correct vision abnormalities. The main sections are configured to effect change in the corneal curvature, topography or refractive correction to treat or correct vision abnormalities such as astigmatism, myopia, and hyperopia.

At least one of the inserts further comprises one or two migration preventing extension sections each coupled to an end of the main section. After implantation in the intracorneal channel, each extension section extends from an end of the main section along the arc angle of the channel. Each extension section may extend from the main section of an insert and be disposed near or abut either the main section of another insert or an end of the channel. In either case, the extension section serves as a stop to prevent or reduce the migration of one or both of the inserts within the channel.

As noted, an insert may comprise an extension section on each of the two ends of the main section. An insert with two extension portions may especially be desirable, for example, where three or more inserts are to be inserted within a single intracorneal channel. Furthermore, various combinations of inserts each with zero (0), one (1) or two (2) extension sections may be inserted within a single channel.

The above is a brief description of some of the features and advantages of the present invention. Other features, advantages, and embodiments will be apparent to those skilled in the art from the following description, accompanying drawings and appended claims.

BRIEF DESCRIPTION OF THE DRAWINGS

Fig. 1 is a schematic representation of a horizontal section of the eye;

Fig. 2 is a schematic illustration of the anterior portion of the eye showing the various layers of the cornea;

5 Fig. 3 shows the corneal implant of the present invention;

Fig. 4 shows the corneal implant of FIG. 3 implanted in the cornea of a human eye through an incision;

Fig. 5A shows the cross-sectional view at line 5A-5A of Fig. 3;

Fig. 5B shows the cross-sectional view at line 5B-5B of Fig. 3;

10 Fig. 5C shows a detailed perspective view of a portion of the corneal implant of Fig. 3;

Fig. 6 shows an alternative embodiment of the corneal implant of the present invention comprising a single insert;

15 Fig. 7 shows yet another alternative embodiment of the corneal implant of the present invention comprising an extendable and compactable migration preventing extension section; and

Fig. 8 shows another alternative embodiment of the corneal implant of the present invention comprising a migration preventing extension section formed from injecting a suitable settable material into the intracorneal channel.

20

DESCRIPTION OF THE INVENTION

Referring to the drawings wherein like reference numerals denote like elements, corneal implants constructed according to the principles and methods of the present invention will be described. However, prior to explaining the details of the inventive
25 corneal implants, an explanation of the physiology of the eye is provided in conjunction with Figs. 1-2. Fig. 1 shows a horizontal section of the eye. Globe 11 of the eye resembles a sphere with an anterior bulged spherical portion representing cornea 12. Globe 11 consists of three concentric coverings enclosing the various transparent media through which the light must pass before reaching the sensitive retina 18. The outermost covering
30 is a fibrous protective portion the posterior five-sixths of which, the sclera 13, is white and

opaque, and is sometimes referred to as the white of the eye where visible to the front. The anterior one-sixth of this outer layer is the transparent cornea 12.

5 A middle covering is mainly vascular and nutritive in function and is comprised of the choroid 14, ciliary body 16 and iris 17. Choroid 14 generally functions to maintain retina 18. Ciliary body 16 is involved in suspending lens 21 and accommodation of the lens. Iris 17 is the most anterior portion of the middle covering of the eye and is arranged in a frontal plane. It is a thin circular disc corresponding to the diaphragm of a camera, and is perforated near its center by a circular aperture called the pupil 19. The size of the pupil varies to regulate the amount of light which reaches retina 18. It contracts also to
10 accommodation, which serves to sharpen the focus by diminishing spherical aberration. Iris 17 divides the space between cornea 12 and lens 21 into an anterior chamber 22 and a posterior chamber 23. The innermost portion of covering is retina 18, consisting of nerve elements which form the true receptive portion for visual impressions.

15 Retina 18 is a part of the brain arising as an outgrowth from the fore-brain, with optic nerve 24 serving as a fiber tract connecting the retina part of the brain with the fore-brain. A layer of rods and cones, lying just beneath a pigmented epithelium on the anterior wall of the retina serve as visual cells or photoreceptors which transform physical energy (light) into nerve impulses.

20 Vitreous body 26 is a transparent gelatinous mass which fills the posterior four-fifths of globe 11. At its sides it supports ciliary body 16 and retina 18. A frontal saucer-shaped depression houses the lens.

Lens 21 of the eye is a transparent bi-convex body of crystalline appearance placed between iris 17 and vitreous body 26. Its axial diameter varies markedly with accommodation. Ciliary zonule 27, consisting of transparent fibers passing between ciliary
25 body 16 and lens 21 serves to hold lens 21 in position and enables the ciliary muscle to act on it.

30 Referring again to cornea 12, this outermost fibrous transparent coating resembles a watch glass. Its curvature is somewhat greater than the rest of the globe and is ideally spherical in nature. However, often it is more curved in one meridian than another giving rise to astigmatism. The central portion of the cornea is called the optical zone with a slight flattening taking place outwardly thereof as the cornea thickens towards its periphery. Most of the refraction of the eye takes place through the cornea.

Fig. 2 is a more detailed drawing of the anterior portion of the globe and further including one embodiment of the corneal implant 10 of the present invention inserted therein. Fig. 2 shows the various layers of cornea 12 comprising an epithelium 31. Epithelial cells are rich in glycogen, enzymes and acetylcholine and their activity regulates the corneal corpuscles and controls the transport of water and electrolytes through the lamellae of the stroma 32 of cornea 12.

An anterior limiting lamina 33, referred to as Bowman's membrane or layer, is positioned between the epithelium 31 and stroma 32 of the cornea. Stroma 32 is comprised of lamella having bands of fibrils parallel to each other and crossing the whole of the cornea. While most of the fibrous bands are parallel to the surface, some are oblique, especially anteriorly. A posterior limiting lamina 34 is referred to as Descemet's membrane. It is a strong membrane sharply defined from stroma 32 and resistant to pathological processes of the cornea.

The endothelium 36 is the most posterior layer of the cornea and consists of a single layer of cells. Endothelium cells function to maintain the transparency of cornea 12. Limbus 37 is the transition zone between the conjunctiva 38 and sclera 13 on the one hand and cornea 12 on the other.

In light of the above explanation of the physiology of the eye, the corneal implant 10 of the present invention will now be described with reference to Figs. 3-8.

Fig. 3 shows the corneal implant 10 of the present invention and Fig. 4 shows the corneal implant 10 inserted or implanted in an appropriately prepared interlamellar, intrastromal channel made within the cornea of a mammalian eye. Corneal implant 10 may comprise one or more intrastromal corneal inserts 40, 50 each comprising a main section 42, 52, respectively. Insert 40 further comprises a first and a second migration preventing extension section or haptic 44, 46. First extension section 44 serves as a stop to reduce or prevent migration of inserts 40, 50 toward each other after implantation within the channel such that neither of main sections 42, 52 would migrate to a location directly under incision 100. In addition, extension section 46 serves as a stop to reduce or prevent migration of insert 40 toward an end of the channel after implantation therein.

Each of intrastromal corneal inserts 40, 50 may also provide an orifice 53 at each end portion of main sections 42, 52, respectively. Each orifices 53 is configured to be engageable with a hooked or curved end of a tool (not shown). Thus, the one or more

orifices 53 facilitate the insertion of the corresponding insert 40 or 50 into the intracorneal channel as well as the removal of the corresponding insert 40 or 50 from the intracorneal channel.

Each of main sections 42, 52 preferably has an arc angle α , radius of curvature, matching or mismatching cone angles, cross-sectional shape, thickness, width, and/or modulus of elasticity, or combinations thereof for changing the refractive properties of an eye. Examples and definitions of these parameters are disclosed in Publication No. WO 97/28759 entitled "Segmented Intrastromal Corneal Insert for Altering Corneal Refractive Properties and Methods Thereof" corresponding to U.S. Ser. No. 08/599,014

The arc angle α of each of main sections 42, 52 refers to the portion of the circumference of the cornea (at a chosen radius) within the intracorneal channel which each main section subtends. The value of α may be any of a wide range of values selected based upon a variety of factors such as the indication to be corrected, the number of insert(s) and the physical arrangement of the insert(s) as they are implanted in the eye. The total value of arc angles α of the inserts is preferably less than 360° and may be any desired value such as less than about 270° , between 20° and 90° , between 60° and 90° . Thus, when two inserts are utilized, each insert is preferably less than 180° . For example, for correction of myopia with minimal impact on astigmatism utilizing two inserts, each insert preferably has an arc angle α of less than 175° and more preferably approximately 165° . For correction of astigmatism utilizing two inserts, each insert preferably has an arc angle α between approximately 45° and 90° . For correction of a combination of myopia and astigmatism utilizing two inserts, each insert preferably has an arc angle α between approximately 90° and 180° .

The opposite ends of a single main section do not meet when the insert is inserted into an intrastromal channel. However, each end of a main section may overlap with an end of another main section, such as in the form of a mitre joint, may abut another main section, or may be parallel with another main section when placed in an intrastromal channel.

The cross-sectional shape and size of main sections 42, 52, along with certain other parameters such as the constituent materials of corneal implant 10, determine in large part the level of correction achievable by use of corneal implant 10. The cross-section of each of main sections 42, 52 may be hexagonal, rectangular, square, elliptical, circular, or any

other appropriate shape and the cross-sectional shape may be symmetrical or asymmetrical. For example, as shown in Fig. 5A, the cross-section of main section 42 may be generally hexagonal with two parallel surfaces 102, 104 and four side surfaces 106, 107, 108, 109, each at an approximate 135° angle relative to the corresponding one of the two parallel surfaces 102, 104.

In one currently preferred embodiment, the generally hexagonal cross-section has a width w of approximately 0.80 mm. The generally hexagonal cross-section also has a height h and the two parallel surfaces 102, 104 has a length A such that the sum of height h and length A is preferably approximately 0.60 mm. Further, where the height h is between approximately 0.20 mm and 0.55 mm, each of the four side surfaces 106, 107, 108, 109 of the main section 42 is preferably rounded with a radius of curvature of approximately 1.25 times the height h or between approximately 0.25 mm and 0.688 mm.

After implantation, an extension section may be disposed between the main section and an end of the channel or between two main sections of two adjoining inserts. The extension section serves as a stop to reduce or prevent migration of one or more inserts. Because migration of a main section to a location directly under an incision of the channel may be especially undesirable, it is preferable that a corneal implant of the present invention comprises an insert including an extension section disposed at a location directly under the incision to prevent such migration of the main section.

The corneal implant of the present invention may be utilized where one or more intracorneal channels are formed in the eye and where the channel extends in one or two directions (clock-wise and/or counter clock-wise) from the initial incision through the corneal layers.

The corneal implant of the present invention may comprise multiple inserts, wherein each insert may be used in isolation, in isolated multiples, in cooperative multiples, or as inserts in a larger assemblage encircling at least a portion of the cornea. With multiple inserts, the main sections of two adjoining inserts may also overlap to provide an added thickness at a desired location to thereby form constructs of varying thickness.

Each of extension sections 42, 52 may also have an arc angle, radius of curvature, cross-sectional shape, thickness, width, and/or modulus of elasticity, or combinations thereof. Each of these parameters may be the same or different from that of each of main sections 42, 52, except that the cross-sectional size of each of extension sections 42, 52 is

substantially less than that of each of main sections 42, 52, as discussed below. Preferably, the radius of curvature of each of extension sections 42, 52 is approximately the same as that of the corresponding main sections 40, 50 such that each insert 40, 50 maintains an approximately constant radius of curvature from the main section to the extension section.

5 The cross-sectional area of each of extension sections 44, 46 may be approximately less than one-half that of the main section 42 and is typically approximately one-fifth that of the main section 42 or less. The smaller cross-sectional area of extension sections 44, 46 ensures that when an extension section is disposed directly under the incision, the extension section does not significantly hinder the flow of nutrients through the interlamellar layers of the cornea nor significantly hinder wound healing at the incision.

10 Figs. 5B and 5C show, respectively, a cross-sectional view along line 5B-5B in Fig. 3 and a perspective view of a portion of the corneal implant 10 of Fig. 3 showing the extension section 44 in more detail. Although only extension section 44 is shown in Figs. 5B and 5C, the following description similarly applies to extension section 46.

15 The cross-sectional shape of each of extension sections 44, 46 may be the same as or different from that of main section 42 or 52. Preferably, each extension sections 44, 46 does not provide any significant adjustment of the corneal curvature for correction of vision abnormalities, although extension sections 44, 46 may provide a small amount of adjustment to the corneal curvature. The cross-sectional shape of each of extension sections 44, 46 is selected based upon the materials of each main and extension section, ease of manufacturability, and ability to reduce or prevent migration of main sections 42, 52.

20 The cross-sectional shape of each of extension sections 44, 46 may be rectangular, hexagonal, square, elliptical, circular, or any other appropriate shape and may be the same or different from each other and/or may be the same or different from the corresponding main section 42, 52. For example, as shown in Figs. 5B and 5C, extension section 44 has a rectangular cross-sectional shape.

25 The extension section 44 has a width B . It is desirable to minimize the width B of extension section 44 in order to minimize blockage of the nutrient flow in the cornea. However, the width B of extension section 44 should be sufficiently large to maintain a sufficient level of structural stability such that the extension section 44 can serve as a

30

migration preventor. For example, in a currently preferred embodiment, the width B of the extension section may be 0.20 mm where the width w of the main section is 0.80 mm.

The extension section 44 has a height C which is preferably approximately 0.30 mm where a corresponding main section 42 has a height h greater than approximately 0.30 mm. Further, where height h of the main section 42 is greater than approximately 0.30 mm, extension section 44 preferably has fillets 110, 112 and chamfer 114 at the interface between the main section 42 and the extension section 44. Fillets 110, 112 and chamfer 114 allow for the smooth transition from the main section 42 to the extension section 44 and also provide additional structural support to reduce the risks of the extension section 44 breaking off of the main section 42. However, regardless of whether the extension section has fillets and/or chamfer at the interface between the main section and the extension section, the cross-sectional area of each insert decreases substantially stepwise from the main section to the extension section

Although not shown, for a main section having a height h of less than or equal to 0.30 mm, the corresponding extension section preferably has a height C equal to the height h of the main section. In other words, extension section would be flush against the main section surfaces 102, 104. Further, where the height h of main section is less than or equal to approximately 0.30 mm, extension section 44 preferably does not include any fillets or chamfers.

The extension section 44 may extend a length of approximately 1.5 mm to 2.5 mm from the corresponding main section 42 and has a cross-sectional area approximately one-fifth that of the main section 42. Preferably, the extension section 44 extends an arc angle of approximately 50° or less. Where two adjacent main sections are separated by an arc angle of approximately 50° or more, the corneal layers defining the intracorneal channel typically converge in the space unfilled by a main section, i.e. the channel space between two main sections, to thereby maintain the respective main sections in place. In other words, where two adjacent main sections are separated by an arc angle of approximately 50° or more, an extension section would generally be unnecessary. Thus, depending upon the desired arc angle of the spacing between two adjacent main sections, the arc angle of the corresponding extension section is preferably approximately equal to the arc angle of the spacing between two adjacent main sections. For example, the arc angle of the extension section, after implantation in the intracorneal channel, may be any arc angle,

preferably less than approximately 50° , such as less than 30° , less than 20° , or between 5° and 10° .

As shown in Fig. 5B, the extension section 44 preferably extends from the main section 42 such that it is centered relative to the width w of the main section 42 while it is off-centered relative to the height h of the main section 42. In particular, the extension section 44 is preferably closer to surface 104 than to the surface 102 of the main section 42 such that extension section 42 is flush with surface 104 and further from the anterior corneal surface. Locating the extension section 44 away from the anterior corneal surface thus locates the extension section 44 away from the incision 100 and thereby minimizes any hindrance to wound healing at the incision 100.

However, if the extension section 42 has a relatively small width B , the extension section 42 may have a height C equal to main section height h , i.e. the extension section extends along the entire height h of the main section 42, because extension section having a small width B already minimizes the hindrance to wound healing at the incision 100. In addition, where extension section 44 comprises a thin wire made of metal or other materials, fibers, or other filamentary materials, the extension section 44 is preferably centrally disposed relative to both the width w and the height h of the cross-section of the main section 42. Centrally locating extension section 44 thus facilitates in the abutment of the extension section 44 against an end of the adjacent main section 52.

Examples of alternative embodiments of corneal implant 10 are shown in Figs. 6-8. For example, as shown in Fig. 6, the corneal implant of the present invention may comprise a single insert 60 comprising main section 62 and one extension section 64 to reduce or prevent migration of the main section toward the location of the incision 100.

In yet another alternative embodiment of the present invention as shown in Fig. 7, extension section 84 of insert 80 is extendable and compactable. Corneal implant 10C comprises inserts 80, 90, wherein extendable and compactable extension section 84 of insert 80 is coupled to main section 82. Extension section 84 abuts main section 92 of insert 90 to reduce or prevent inserts 80, 90 from migration. Because extension section 84 is extendable and compactable, the separation distance between inserts 80, 90 is adjustable by the operator. Extendable and compactable extension section 84 thus provides a range of separation distances between inserts 80, 90, for example, between 0.25 mm and 25 mm. Further, the radius of the overall corneal implant 10C may also be adjustable.

Extendable and compactable extension section 84 may also be coupled to main section 92 of insert 90 to facilitate adjustment of the separation distance by the operator after implantation of corneal implant 100C. Such coupling ensures that the main section 92 adjoins the extension section 84. Alternatively or additionally, extendable and compactable extension section 84 may abut an end of the intracorneal channel such that the distance from incision 100 is adjustable by the operator.

Extension section 84 preferably has a serrated, saw-toothed or coiled configuration and preferably is made of a relatively ductile material capable of retaining its configuration over time. For example, extension section 84 may be made of certain metals, fibers, plastics, or other polymers such as polymethylmethacrylate (PMMA), polycarbonate and nitinol. Preferably, such an extension section 84 is preferably utilized with an insert having a relatively rigid main section.

Extension section may alternatively be formed by injecting a settable material into the intracorneal channel after insertion of the insert 10 therein. As shown in Fig. 8, injected extension section 74 is disposed between an end of main section 72 of insert 70 and incision 100. After inserting main section 72 into the intracorneal channel, extension section 74 is formed by injecting a settable soft polymer, gel, collagen, fibrinogen, or glue preformed hydrogel through incision 100 into the intracorneal channel. After the injected material sets, extension section 74 thus reduces or prevents migration of main section 72 toward incision 100. Suitable injectable polymers are well known and include polyHEMA hydrogel, cross-linked collagen, cross-linked hyaluronic acid, siloxane gels, and organic-siloxane gels such as cross-linked methy vinyl siloxane gels.

Each of inserts 40, 50 is made of a physiologically compatible material for effecting change in the corneal curvature, topography or refractive correction to treat or correct vision abnormalities such as astigmatism, myopia, and hyperopia. A main section may be of one or more nontissue materials, synthetic or natural polymers, hydrophilic or hydrophobic, or a hybrid comprising layered materials. The main sections may comprise of one or more polymers having a high and/or low modulus of elasticity. In addition, the main section may have an inner portion or be hollow or adapted to be fillable with a biologic agent, drug or other liquid, emulsified, or time-release eye treatment or diagnostic material, or gel or settable polymer.

An arcuate main section has sufficient structural integrity to approximate the shape of some portion of the channel. The arcuate main section is of selected size, arc angle and/or radius of curvature. The materials used in an arcuate main section may be relatively stiff (high modulus of elasticity) physiologically acceptable polymers such as polymethyl-
5 methacrylate (PMMA), TEFLON, polycarbonate, polysulfones, epoxies, or polyolefins such as polyethylene, polypropylene, polybutylene, and their mixtures and interpolymers. Such high modulus of elasticity materials have moduli of elasticity of greater than about 3.5 kpsi. Many of these polymers are known in the art to be appropriately used in hard contact lenses. Obviously, any polymer which is physiologically suitable for introduction into the
10 body is useful in the inserts of this invention. Many of the listed polymers are known to be suitable as hard contact lenses. For instance, PMMA has a long history in ophthalmological usage and consequently is quite desirable for use in these main sections.

Additionally or alternatively, the polymeric material making up the main sections may be pliable. A pliable main section is such that prior to its insertion into the
15 intracorneal channel, it is quite flexible and need not be preformed to the shape and curvature of the intrastromal channel. The pliable main section will, after insertion into the interlamellar channel, conform to the shape of the channel. Specifically, the pliable main section will easily transform from a preinsertion shape to the shape of the intrastromal channel only by imposition of the force inherently exerted by the intrachannel walls.

The materials used in pliable main sections are physiologically acceptable, low modulus polymers, e.g., materials having a modulus of elasticity below about 3.5 kpsi, more preferably between 1 psi and 1 kpsi, and most preferably between 1 psi and 500 psi, which are physiologically compatible with the eye. Most polymeric materials used in soft contact lenses are suitable for the pliable main sections of the present invention. The class
20 includes physiologically compatible elastomers and such crosslinked polymeric gels as polyhydroxyethylmethyl acrylate (Poly HEMA) or polyvinylpyrrolidone (PVP), polyethylene oxide, or polyacrylates, polyacrylic acid and its derivatives, their copolymers and interpolymers, and the like as well as biologic polymers such as crosslinked dextran, crosslinked heparin or hyaluronic acid.

In many instances, the main sections may be a hybrid, i.e. the main sections are
30 made up of a number of polymeric layers often with a soft or hydratable polymer on their outer surface. Examples of such hybrids are disclosed in International Pub. No. WO

94/03129, entitled "Hybrid Intrastromal Corneal Ring", corresponding to U.S. Ser. No. 07/927,165. When the main section is a hybrid, both the inner and outer portions may comprise variously one or more high or low modulus, physiologically compatible polymers or a composite of a low modulus polymer and a high modulus polymer. The inner portion may comprise a gel or a polymeric material which is polymerized in situ after introduction
5 into a hollow center layer.

If hydratable polymers are used, they may be hydrated before or after introduction into the intrastromal channel created by the surgical device used to introduce these corneal inserts into the eye. If the main section is made of a hydratable polymer and the outer layer
10 is hydrated before insertion into the eye, the final size of the main section will be set before insertion. If the hydratable polymers are allowed to hydrate within the corneal space, the corneal implant (if appropriate polymers are chosen) will swell within the eye to its final size.

If partially or fully hydrated prior to implantation, because hydrated hydrophilic
15 polymers typically have a low coefficient of friction, the outer layer of the main section often provides a measure of lubricity to the corneal implant, allowing it to be implanted in to the intracorneal channel with greater ease. It is usually desirable to at least partially hydrate the hybrid intrastromal main section in that, otherwise, the main section during its traverse through the channel may desiccate the path and stick to the interior wall of the
20 channel.

Suitable hydrophilic polymers include polyhydroxyethylmethacrylate (pHEMA), N-substituted acrylamides, polyvinylpyrrolidone (PVP), polyacrylamide, polyglycerylmethacrylate, polyethyleneoxide, polyvinyl alcohol, polyacrylic acid, polymethacrylic acid, poly (N, N-dimethyl amino propyl-N¹-acrylamide) and their
25 copolymers and their combinations with hydrophilic and hydrophobic comonomers, crosslinks, and other modifiers. Thermoplastic hydrogels include hydropolyacrylonitrile, polyvinyl alcohol derivatives, hydrophilic polyurethanes, styrene-PVP block copolymers and the like.

Each main section may be lubricated with suitable ocular lubricants such as
30 hyaluronic acid, methylethyl cellulose, dextran solutions, glycerine solutions, polysaccharides, or oligosaccharides upon its introduction to help with the insertion particularly if one wishes to insert intrastromal main section of hydrophilic polymers

without prior hydration. If a hybrid main section comprising a hydrophilic polymeric or a hydrophilic polymer covering is inserted into the eye without prior hydration, subsequent to the insertion, the intrastromal main section will swell to its final size or thickness within the eye. This swelling often permits the inclusion of larger intrastromal inserts than would normally be accommodated within normal sized intrastromal channels.

Low modulus polymers used in the present invention are often absorbent, particularly if they are hydratable, and may be infused with a drug or biologic agent which may be slowly released from the corneal implant after implantation of the intrastromal inserts. For instance, the low modulus polymer may be loaded with a drug such as dexamethasone to reduce acute inflammatory response to implanting the corneal inserts. This drug helps to prevent undesirable scarring or vascular ingrowth toward the intrastromal insert. Similarly, heparin, corticosteroids, antimetabolites, antifibrotics, antiinflammatories, anti-scar-forming, anti-adhesion, and antiangiogenesis factors (such as nicotine adenine dinucleotide (NAD⁺)) may be included to reduce or prevent angiogenesis and inflammation. Clearly, there are a variety of other drugs suitable for inclusion in the intrastromal insert. The choice will depend upon the use to which the drugs are put.

Optionally, the main section may contain filamentary material in the form of a single or multiple threads, randomly included filaments, or woven mattes to reinforce the insert during, e.g., insertion or removal from the intrastromal channel. The extension section may also be a mere continuation(s) of some or all of the filamentary material.

Corneal implant 10 may be formed with a predetermined arcuate shape and/or pliable so that its arcuate shape may be readily changed. Although each of main sections 42, 52 may be made of different materials, main sections 42, 52 are preferably both arcuate or both pliable and made of the same or similar materials. In addition, although each of extension sections 44, 46 may be made of different materials, extension sections 44, 46 are preferably both made of the same or similar materials. Furthermore, each of extension sections 44, 46 may be made integrally of the same materials as main section 42. For example, corneal implant 10 may be extruded from one material and then machining or otherwise removing material from the extruded piece to form the extension section(s).

Even if extension sections 44, 46 were not formed of the same materials as main section 42, the examples of suitable materials for forming an arcuate main section and a

pliable main section, as set forth below, may also be utilized in forming extension section 44 and/or 46.

Thus, as noted, the above examples of suitable materials for forming a main section may be utilized in integrally forming an extension section of the same material as the main section. Where the extension section is not integrally formed of the same material as the main section, other materials which are suitable for forming a main section may be utilized in forming the extension section.

Alternatively, each of extension sections 44, 46 may be single or multiple strands embedded at an end of main section 42. The strands may be made of one or more metals, plastics, filamentary materials and/or polymers, such as materials use for hip joints such as cobalt-chrome alloys.

Procedure For Impantation

Corneal implant 10 is placed into the eye using procedures similar to those disclosed in International Publication Nos. WO 93/20763, entitled "Corneal Vacuum Centering Guide and Dissector", corresponding to U.S. Ser. No. 07/867,745, WO 95/18569, entitled "System for Inserting Material Into Corneal Stroma", corresponding to U.S. Ser. No. 08/178,577, and WO 98/03136, entitled "Ophthalmological Instruments and Methods of Use", corresponding to U.S. Ser. No. 60/020,996, as well as in our U.S. Ser. Nos. 08/896,754, entitled "Corneal Vacuum Centering Guide", filed 7/18/97 and 08/993,445, entitled "Corneal pocketing Tool", filed 12/18/97, U.S. Ser. No 08/896,754.

Initially, the geometric center of the cornea is marked with a blunt instrument (e.g., a Sinsky hook) using an operating microscope for fixation. A zone marker (e.g., an 11 mm zone marker) can be used to aid in locating the center point. A sterile marking pen may be used to enhance the mark. This center mark is used as the reference point throughout the surgical procedure.

Next, the contact surface of an incision and placement marker is marked, using a sterile marking pen, for example. The incision and placement marker is then centered on the center mark created at the geometric center described above, by lining up the reticle of the incision and placement marker with the center mark. The contact surface of the marker is contacted lightly against the cornea, making an inked marking of where the radial incision will be made and, in the case of segments, where the segments will be positioned.

A visual verification is made that the marks are at least 1 mm from the limbus in all directions. If the marks are too close to the limbus, re-marking of the geometric center of the cornea is required, to get closer to the actual geometric center.

5 A pachymetry measurement is made to determine the thickness of the corneal tissue at the incision site. Next, a calibrated, diamond knife is set to 0.430 mm (430 μ) or 68% of the intraoperative pachymetry reading taken at the incision site. The diamond should either have an angled cutting edge of 15° or less, or have a rectangular blade of 1 mm width or less.

10 A radial incision is made by tracing to the outside edge of the incision mark. The incision length may range from about 1.0 to 1.8 mm, and is preferably about 1.3 mm. Special care should be taken to ensure that the incision is kept approximately 1 mm away from the limbus. The incision area is then thoroughly irrigated with balanced salt solution after completing the incision. A Merocel® spear or equivalent is used to remove any loose epithelial cells and excess balanced salt solution from the edges of the incision. The
15 epithelium may be rolled away from the incision edges. The incision is again thoroughly irrigated with balanced salt solution prior to any instrument insertion.

A specialized pocketing tool, such as those described in co-pending U.S. application titled "CORNEAL POCKETING TOOL", filed on December 18, 1997, is next used to separate the stromal layers at the appropriate depth at the base of the incision. After placing
20 the pocketing tool instrument in the incision, the pocketing tool is rotated to create an intrastromal separation or pocket.

The pocket may be enlarged as desired using a stromal spreader such as is described in co-pending U.S. Application Serial No. 08/896,792 filed on July 18, 1997 titled
25 "OPHTHALMOSURGICAL INSTRUMENTS AND METHODS OF USE". The tip of the spreader is inserted vertically down into the incision until it contacts the bottom of the incision. A blunt dissection or enlarged pocket is then created on one side of the base of the incision by carefully rotating the blade of the spreader instrument within a single stromal plane. The procedure is then repeated on the other side of the incision base. The resultant pockets should be at the same depth as the incision base, as wide as the full
30 incision length, and extend to the full length of the spreader tip.

Corneal thickness gauges may be used to estimate the depth of both pockets. If the pockets are not deep enough in the corneal stroma, the incision is made slightly deeper with

the diamond knife and a second pocket or set of pockets are then created at a deeper level with the pocketing tool and spreader in the manner described above.

The incision and placement marker is next indexed into a vacuum centering guide (VCG) such as those described in Loomas, U.S. Patent No. 5,403,335 or pending U.S. Patent Application No. 08/796,595, for example. The reticle is aligned with the center mark to center the VCG on the center mark. The VCG is then lowered to contact the sclera of the eye while maintaining centration, and then vacuum is slowly applied. Placement of the VCG over the incision and placement marker, together with proper alignment of the marker on both the center mark and the actual incision, ensure that a window in the VCG is centered about the incision site. The vacuum should start in the range of 12-15 inches of Hg. Once a vacuum seal has been established, a confirmation that the VCG is properly placed is made, by checking centration. If the VCG is not properly positioned, the vacuum must be released, and the above procedure regarding the VCG must be repeated. If the VCG is determined to be properly positioned, the vacuum is then slowly increased to 18-20 inches of Hg. It is recommended that the vacuum not exceed 22 inches of Hg. Next, the incision and placement marker is removed from the VCG.

While maintaining the position of the VCG, a counterclockwise (CCW) dissector, such as that described in copending U.S. Application No. 08/676,377, is inserted into the VCG. The dissector body should be rotated until the tip of the dissector blade is adjacent to the incision site. A counterclockwise glide, such as described in U.S. Application No. 08/896,792, for example, is inserted in the incision, at least 1 mm into the pocket and the dissector tip is rotated under the foot of the glide. Counterclockwise rotation of the dissector body allows the dissector tip to enter the pocket underneath the glide. The dissector blade is then advanced approximately 1 mm to 2 mm, then stopped. The glide is removed while leaving the dissector tip in position in the pocket.

While holding the VCG vertically with one hand, the dissector is rotated counterclockwise from the incision to create a stromal channel. Rotation of the dissector in a counterclockwise direction is continued until the support spoke of the dissector blade contacts the incision edge. Then the dissector blade is removed from the channel by rotating the dissector body clockwise until the dissector tip exits the channel. The dissector is then removed from the VCG.

While maintaining the position of the VCG, a clockwise (CW) dissector, such as that described in copending U.S. Application No. 08/676,377, is inserted into the VCG. The dissector body is rotated until the tip of the dissector is adjacent to the incision site. Next, a clockwise (CW) glide, such as described in U.S. Application No. 08/896,792, for example, is inserted at least 1 mm into the opposite pocket and the dissector tip is rotated under the foot of the glide. Clockwise rotation of the dissector body drives the dissector tip into the pocket. The dissector tip should be inserted underneath the glide foot to enter the pocket. The glide blade is next advanced approximately 1 mm to 2 mm, then stopped in its position. The glide is removed while leaving the dissector tip in position in the pocket.

While holding the VCG vertically with one hand, the dissector is rotated clockwise from the incision to create a second stromal channel. The clockwise rotation of the dissector is continued until the support spoke of the dissector blade contacts the incision edge. Then the dissector blade is removed from the channel by rotating the dissector body counterclockwise until the dissector tip exits the channel. The dissector is then removed from the VCG.

The vacuum is next released and the VCG is removed from the eye. Any stromal debris from the incision site is removed and the incision area is again thoroughly irrigated, using balanced salt solution, prior to insertion of each segment into the stromal channel. Optionally, a small amount of Celluvisc® or an equivalent lubricating agent may be applied to the surface of the cornea, to avoid direct contact of the segments with the epithelium, although this is not preferred.

Each segment, or the ring, is picked up using forceps, such as those described in copending U.S. application no. 08/896,792, for example. The leading end of each segment, or of the split ring is fed, into the stromal channel from the incision. One segment is rotated clockwise and the second segment is rotated counterclockwise. A ring may be inserted in either a clockwise or counterclockwise manner. The segments have an anterior/posterior orientation. The segment should be placed in the stroma concave side down, such that the cone angle of the segment is most closely matched with the curvature of the cornea.

Using the forceps or a Sinsky Hook, the ring or the segments are manipulated into the desired location within the channel, aligning the outside edge of the segments with the appropriate ink markings left by the incision and placement marker, and the leading ends of

the segments are aligned with the appropriate ink markings created by the incision and placement marker.

Again any stromal debris is removed from the incision area, and the incision area is thoroughly irrigated with balanced salt solution. The tissue edges of the incision are gently approximated to close, and the incision may be closed with one to two interrupted sutures using an ophthalmic suture, preferably 10-0 or 11-0 nylon or equivalent. The suture depth should be to the level of the stromal pocket. Care should be taken to avoid microperforation by the suture needle. If two sutures are placed, the sutures should trisect the incision line from the superior and inferior aspects of the incision to insure apposition of the anterior edges of the incision.

The anterior incision edges must be opposed to prevent epithelial cells from entering the incision. Care should be taken to ensure that tension across the sutures is evenly applied, however overtightening of the sutures should be avoided as this may induce astigmatism.

Although various embodiments of the present invention have been described, the descriptions are intended to be merely illustrative not intended to limit the invention in any way. Further, each of the above-referenced documents are incorporated in their entireties herein by reference, but modified to take into account that the intracorneal inserts may be pliable and/or arcuate. Thus, it will be apparent to those skilled in the art that modifications within the spirit of the disclosure may be made to the embodiments as described without departing from the scope of the claims set forth below.

WHAT IS CLAIMED IS:

- 5 1. A corneal implant comprising a physiologically compatible first insert adapted for implantation within a human cornea, said insert comprising a first main section and a first extension section, said main section having a first end and a second end, said first extension section extending from said first end of said main section and configured to reduce migration of the corneal implant within the cornea after implantation therein, the cross-sectional area of the corneal implant decreases substantially stepwise from said main section to said extension section.
- 10 2. The corneal implant of claim 1 wherein said main section is configured to alter the topography of the cornea in a manner that effects correction of a predetermined refractive disorder of the eye.
3. The corneal implant of claim 1 wherein said main section is configured to alter the refractive correction of the eye by substantially a predetermined amount.
- 15 4. The corneal implant of claim 1 wherein said main section is configured to alter the shape of the cornea by substantially a predetermined amount.
- 20 5. The corneal implant of claim 1, further comprising a second insert adapted for implantation within the cornea adjoining said extension section of said first insert, said second insert having a second main section, wherein after implantation of said inserts in the cornea said extension section reduces migration of at least one of said first and second inserts within the cornea, and wherein the cross-sectional area of the corneal implant decreases substantially stepwise from said second main section to said extension section.
- 25 6. The corneal implant of claim 5 wherein said first insert further comprises a second extension section extending from a second end of said first main section, said second extension section being configured to reduce migration of the corneal implant within the cornea after implantation therein, wherein the cross-sectional area of the corneal implant decreases substantially stepwise from said first main section to said second extension section.

7. The corneal implant of claim 5 wherein said main sections are configured to alter the topography of the cornea in a manner that effects correction of a predetermined refractive disorder of the eye.

5 8. The corneal implant of claim 5 wherein said main sections are configured to alter the refractive correction of the eye by substantially a predetermined amount.

9. The corneal implant of claim 5 wherein said main sections are configured to alter the shape of the cornea by substantially a predetermined amount.

10 10. The corneal implant of claim 5 wherein said extension section comprises a material selected from the group consisting of metal, polymer, fiber, and injected gel, collagen, fibrinogen, and glue preformed hydrogel.

11. The corneal implant of claim 5 wherein said extension section comprises a wire, said wire extending from said main section.

12. The corneal implant of claim 5 wherein said extension section is integrally formed of the same material as said main section.

15 13. The corneal implant of claim 5 wherein said extension section subtends an arc less than about 50° of the cornea's circumference.

14. The corneal implant of claim 13 wherein said extension section subtends an arc less than about 30° of the cornea's circumference.

20 15. The corneal implant of claim 14 wherein said extension section subtends an arc less than about 20° of the cornea's circumference.

16. The corneal implant of claim 15 wherein said extension section subtends an arc less than about 5-10° of the cornea's circumference.

17. The corneal implant of claim 5 wherein the corneal implant subtends an arc less than 360° after implantation in the cornea in a circumferential direction thereof.

25 18. The corneal implant of claim 17 wherein the corneal implant subtends an arc less than about 320° of the cornea's circumference.

19. The corneal implant of claim 18 wherein the corneal implant subtends an arc less than about 270° of the cornea's circumference.

20. The corneal implant of claim 19 wherein the corneal implant subtends an arc 20° to 90° of the cornea's circumference.

5 21. The corneal implant of claim 20 wherein the corneal implant subtends an arc an arc of 60° to 90° of the cornea's circumference.

10 22. The corneal implant of claim 5 wherein at least one of said main sections is pliable and has a preimplantation configuration, said pliable main section being transformable between said preimplantation configuration and a second configuration when introduced into a circumferentially extending channel formed in the cornea.

15 23. The corneal implant of claim 5 wherein at least one of said main sections is sufficiently pliable such that when said pliable main section is introduced into a circumferentially extending channel formed in the cornea, the radius of curvature of said pliable main section generally may conform to that of the channel in response to the force imposed by the cornea on said pliable main section.

24. The corneal implant of claim 5 wherein at least one of said main sections comprises a material having a modulus of elasticity below about 3.5 kpsi.

25. The corneal implant of claim 24 wherein said material has a modulus of elasticity below about 1 kpsi.

20 26. The corneal implant of claim 25 wherein said material has a modulus of elasticity below 500 psi.

27. The corneal implant of claim 5 wherein at least one of said main sections has a predetermined cross-sectional shape and is constructed to substantially retain said cross-sectional shape over time after implantation within a human cornea.

25 28. The corneal implant of claim 5 wherein at least one of said main sections has a hexagonal cross section.

29. The corneal implant of claim 5 wherein at least one of said main sections has a circular cross section.

30. The corneal implant of claim 5 wherein at least one of said main sections comprises a synthetic polymeric material.

5 31. The corneal implant of claim 1 wherein the main section has a first radius of curvature and said extension section has a second radius of curvature different from the first radius of curvature.

10 32. A corneal implant adapted for placement within a human cornea, said implant comprising a first portion and a second portion extending from an end of the first portion, the second portion having a cross-sectional area that is substantially less than a cross-sectional area of the first portion.

33. The corneal implant of claim 32 wherein the cross-sectional area of the second portion is less than about one-half the cross-sectional area of the first portion.

15 34. The corneal implant of claim 33 wherein the cross-sectional area of the second portion is about one-fifth the cross-sectional area of the first portion.

35. The corneal implant of claim 33 wherein the cross-sectional area of the second portion is less than approximately one-fifth the cross-sectional area of the first portion.

36. The corneal implant of claim 32 wherein the second portion subtends an arc angle less than approximately 50° .

20 37. The corneal implant of claim 32 wherein the second portion subtends an arc angle of less than about 50° .

38. The corneal implant of claim 37 wherein the second portion subtends an arc angle of between 5° and 10° .

25 39. The corneal implant of claim 32 wherein the cross-sectional area of the implant decreases substantially stepwise from the first portion to the second portion.

40. The corneal implant of claim 32 wherein said second portion is configured to reduce migration of the corneal implant within the cornea after implantation therein.

41. The corneal implant of claim 32 wherein the second portion comprises a material selected from the group consisting of metal, polymer, fiber, and injected gel,
5 collagen, fibrinogen, and glue preformed hydrogel.

42. The corneal implant of claim 32 wherein the second portion is integrally formed with the first portion.

43. The corneal implant of claim 32 wherein the second portion is coupled to the first portion, the first portion includes a first material and the second portion including a
10 second material different from the first material.

44. The corneal implant of claim 32 further comprising a third portion extending from another end of the first portion and having a cross-sectional area that is substantially less than the cross-sectional area of the first portion.

45. The corneal implant of claim 32 wherein the second portion comprises a wire
15 made of a material selected from metal, fiber, and polymer.

46. The corneal implant of claim 32 wherein the second portion has an adjustable length.

47. The corneal implant of claim 46 wherein the second portion section has a serrated configuration.

20 48. A corneal refractive correction system adapted for placement within a channel formed in a human cornea comprising:

a first implant having a main portion and an extension portion extending from the main portion and having a cross-sectional area substantially less than a cross-sectional area of the main portion.

25 a second implant having a main portion for placement within the corneal channel adjacent to the extension section of the first implant.

49. The system of claim 48 wherein the cross-sectional area of the extension portion is about one-fifth the cross-sectional area of the main portion.

50. The system of claim 48 wherein the cross-sectional area of the extension portion is less than about one-fifth the cross-sectional area of the main portion.

5 51. The system of claim 48 wherein the cross-sectional area of the extension portion is between one-fifth and one-half the cross-sectional area of the main portion.

10 52. A method for effecting refractive correction of a human eye, comprising the step of introducing a first implant into a channel formed in the cornea of a human eye, the first implant adapted to be placed within the corneal channel and having a first portion and a second portion extending from an end of the first portion, the second portion having a cross-sectional area that is substantially less than a cross-sectional area of the first portion.

53. The method of claim 52 wherein the step of introducing includes introducing the first portion into the channel before introducing the second portion therein.

15 54. The method of claim 53 wherein the step of introducing includes placing a free end of the second portion near an opening to the channel.

20 55. The method of claim 53 further comprising the step of introducing a second implant into the channel, the second implant having a first portion is adapted to be placed within the corneal channel, wherein the step of introducing a second implant is such that an end of the first portion of the second implant is adjacent a free end of the second portion of the first implant, wherein

56. The method of claim 55 wherein the second implant further has a second portion extending from the first portion of the second implant and wherein the step of introducing the second implant includes placing a free end of the second portion near an opening to the channel.

25

1/4

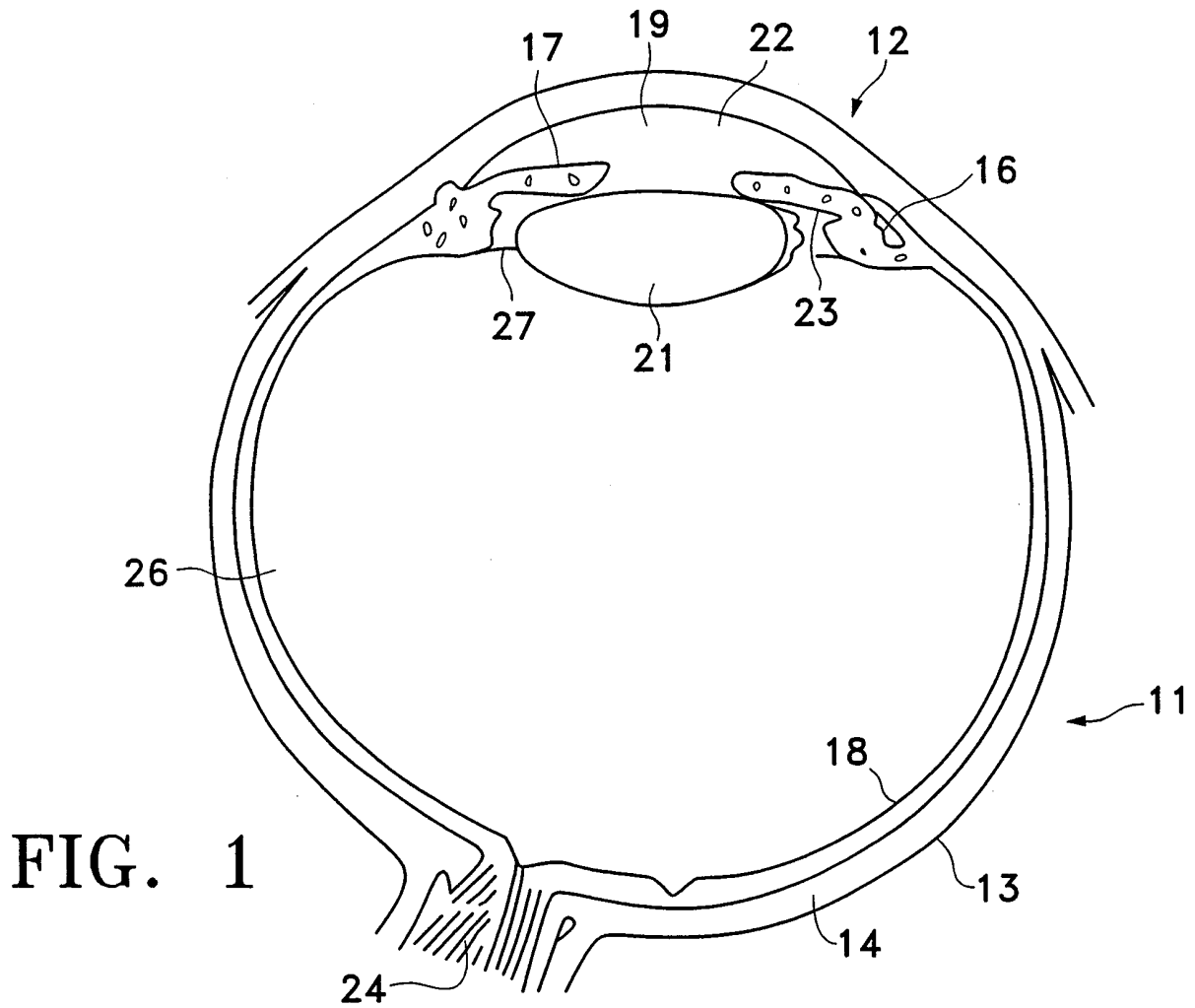

FIG. 1

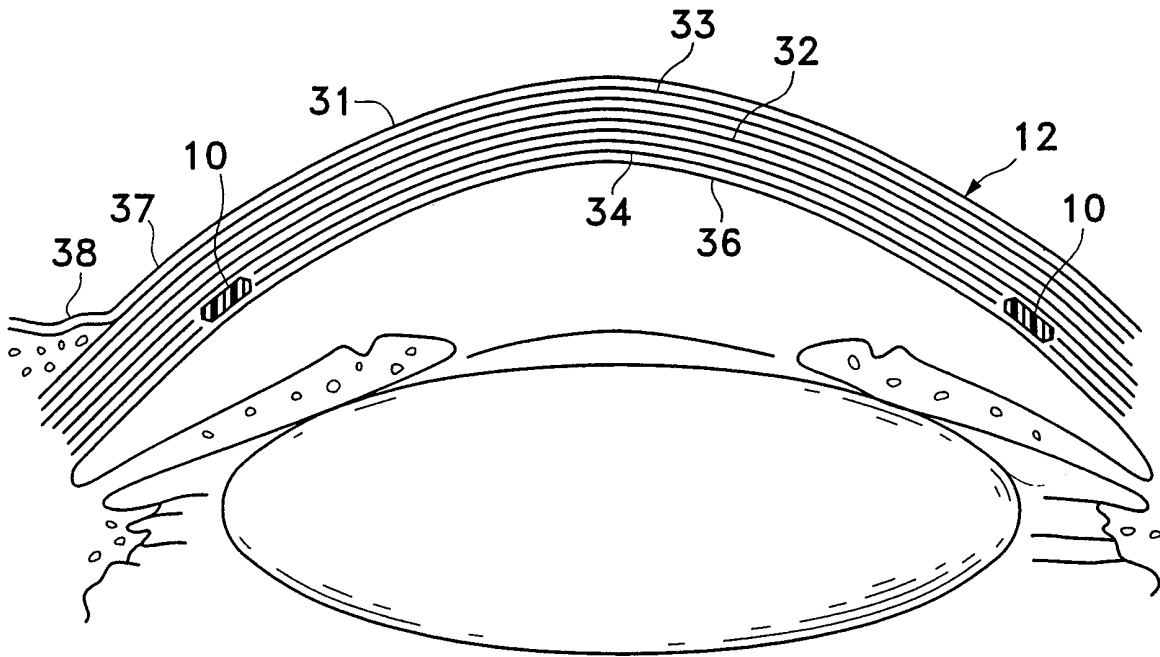

FIG. 2

SUBSTITUTE SHEET (RULE 26)

2/4

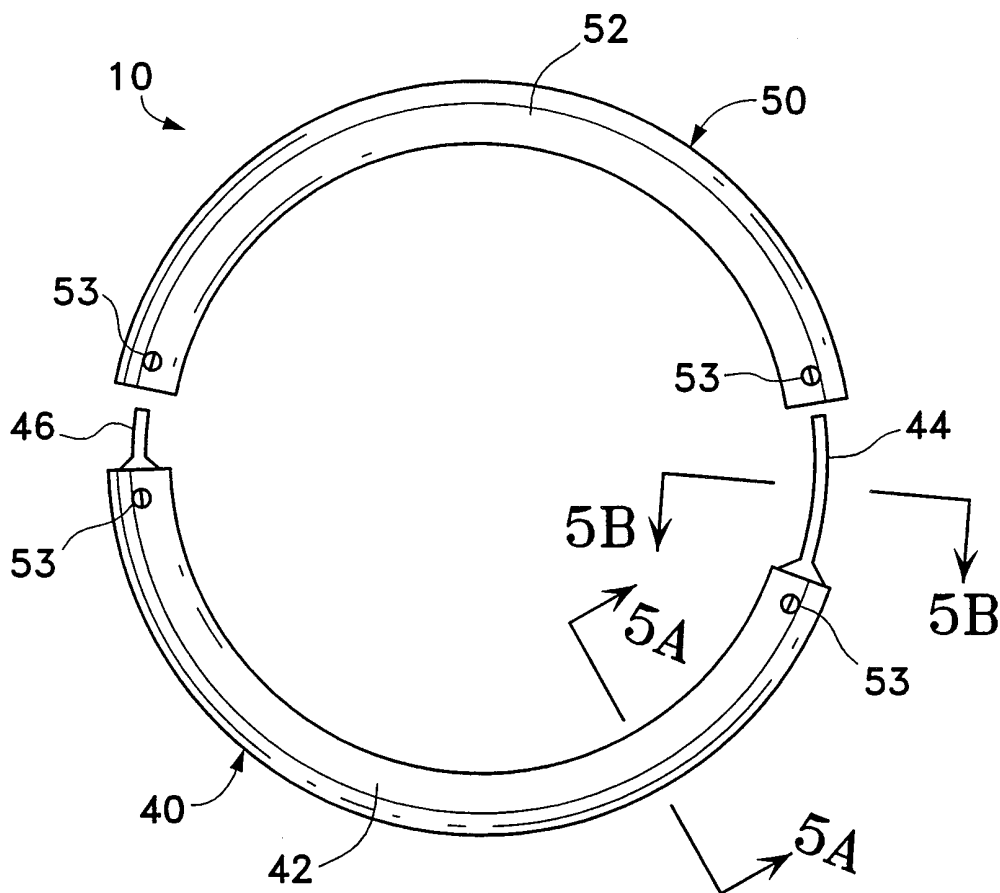

FIG. 3

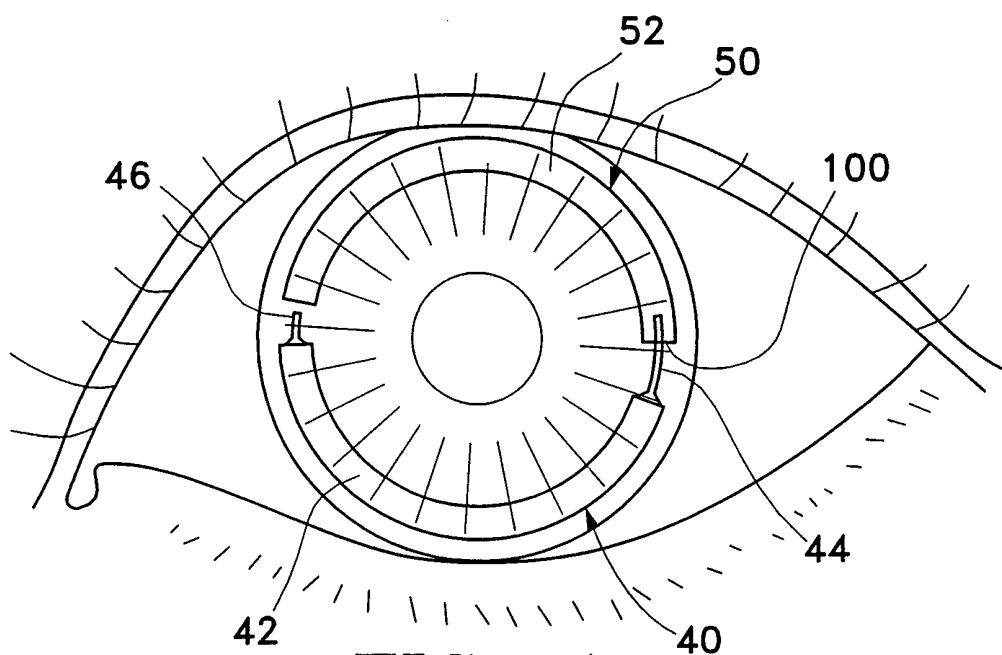

FIG. 4

3/4

FIG. 5A

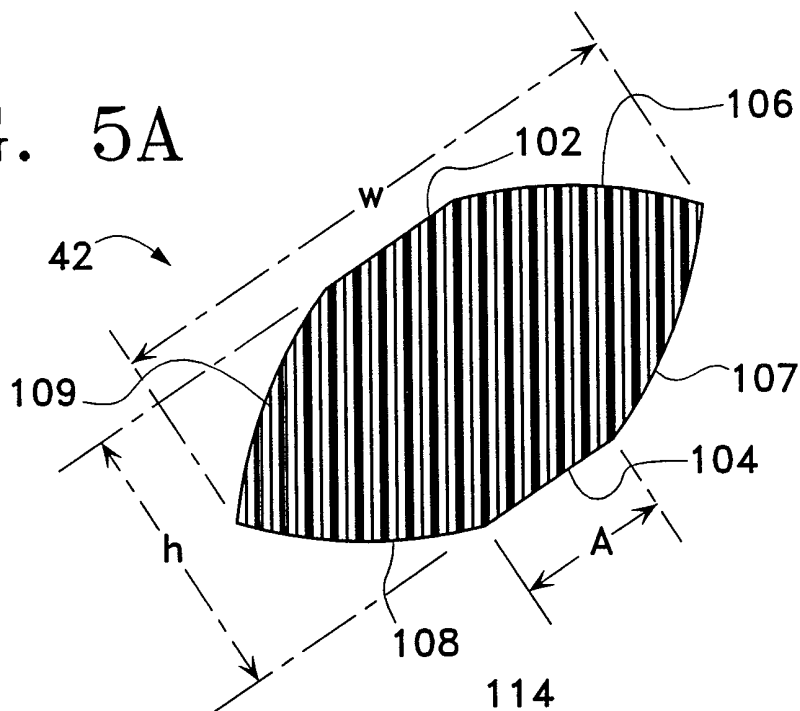

FIG. 5B

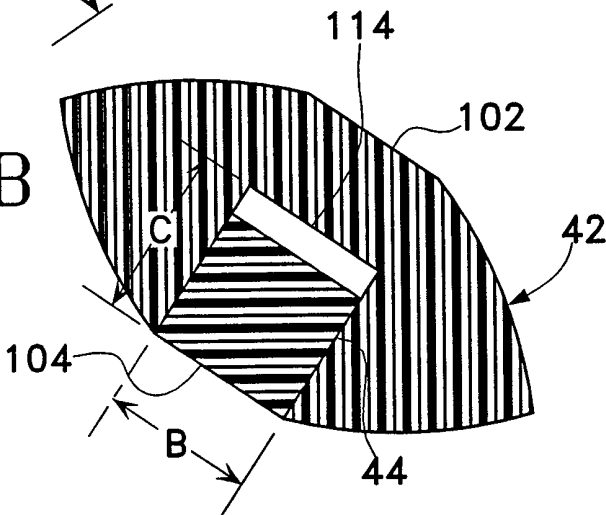

FIG. 5C

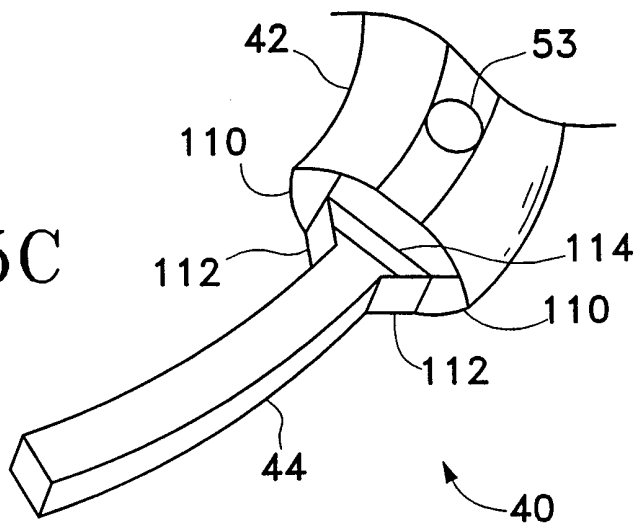

FIG. 6

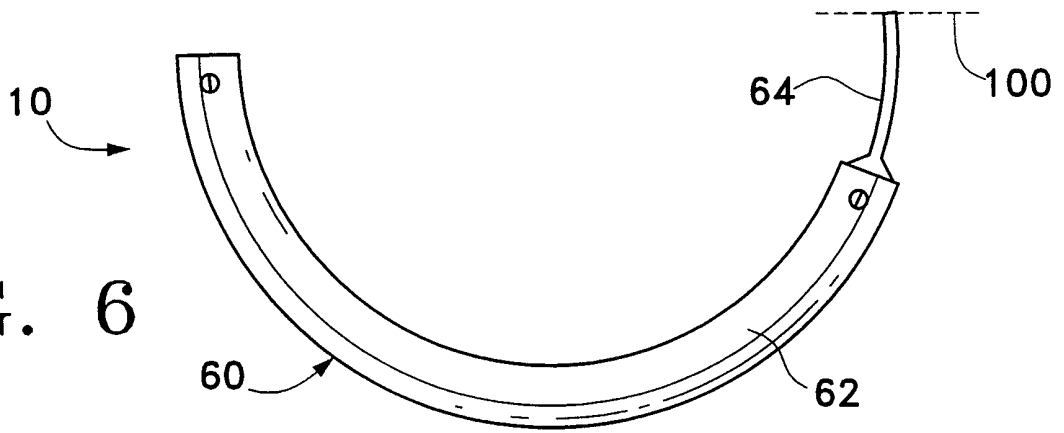

FIG. 7

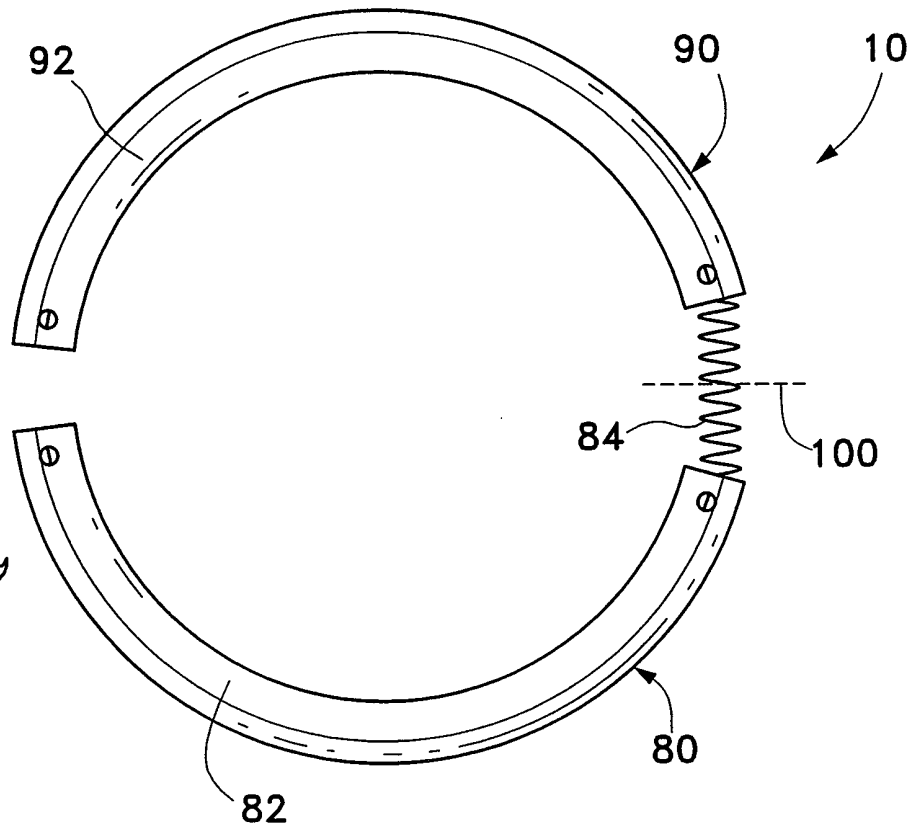
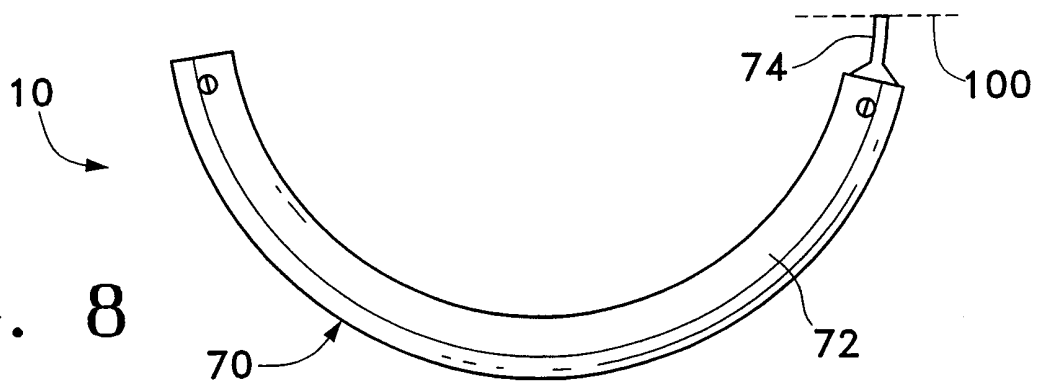

FIG. 8



INTERNATIONAL SEARCH REPORT

International Application No

PCT/US 99/17762

A. CLASSIFICATION OF SUBJECT MATTER
IPC 7 A61F2/14

According to International Patent Classification (IPC) or to both national classification and IPC

B. FIELDS SEARCHED

Minimum documentation searched (classification system followed by classification symbols)

IPC 7 A61F

Documentation searched other than minimum documentation to the extent that such documents are included in the fields searched

Electronic data base consulted during the international search (name of data base and, where practical, search terms used)

C. DOCUMENTS CONSIDERED TO BE RELEVANT

Category °	Citation of document, with indication, where appropriate, of the relevant passages	Relevant to claim No.
X	<p>US 5 323 788 A (SILVESTRINI) 28 June 1994 (1994-06-28)</p> <p>column 5, line 41 -column 7, line 24 column 7, line 66 -column 9, line 13; figures 5,7,9E,10</p> <p align="center">--- -/--</p>	<p>1-4, 32-42, 44,45</p>

Further documents are listed in the continuation of box C.

Patent family members are listed in annex.

° Special categories of cited documents :

- *A* document defining the general state of the art which is not considered to be of particular relevance
- *E* earlier document but published on or after the international filing date
- *L* document which may throw doubts on priority claim(s) or which is cited to establish the publication date of another citation or other special reason (as specified)
- *O* document referring to an oral disclosure, use, exhibition or other means
- *P* document published prior to the international filing date but later than the priority date claimed

- *T* later document published after the international filing date or priority date and not in conflict with the application but cited to understand the principle or theory underlying the invention
- *X* document of particular relevance; the claimed invention cannot be considered novel or cannot be considered to involve an inventive step when the document is taken alone
- *Y* document of particular relevance; the claimed invention cannot be considered to involve an inventive step when the document is combined with one or more other such documents, such combination being obvious to a person skilled in the art.
- * & * document member of the same patent family

Date of the actual completion of the international search

23 December 1999

Date of mailing of the international search report

19.01.00

Name and mailing address of the ISA

European Patent Office, P.B. 5818 Patentlaan 2
NL - 2280 HV Rijswijk
Tel. (+31-70) 340-2040, Tx. 31 651 epo nl,
Fax: (+31-70) 340-3016

Authorized officer

Arjona Lopez, G

INTERNATIONAL SEARCH REPORT

International Application No
PCT/US 99/17762

C.(Continuation) DOCUMENTS CONSIDERED TO BE RELEVANT		
Category °	Citation of document, with indication, where appropriate, of the relevant passages	Relevant to claim No.
2	X WO 95 03755 A (KERA VISION INC ;SILVESTRINI THOMAS A (US)) 9 February 1995 (1995-02-09) cited in the application page 10, line 10 - line 31 page 13, line 7 - line 29 page 14, line 7 - line 11 page 17, line 30 -page 18, line 7 page 20, line 32 -page 21, line 8; figures 4B,6,11,12 ---	1-11,13, 17-30, 32,33, 35-37, 39,44, 46,48,51
2	X WO 97 28759 A (KERA VISION INC ;SILVESTRINI THOMAS A (US)) 14 August 1997 (1997-08-14) cited in the application claims 13,15 page 3, line 10 - line 17 page 18, line 13 -page 19, line 20 page 20, line 13 - line 30 page 22, line 14 -page 23, line 12 page 25, line 6 - line 12 page 28, line 12 - line 32; figures 16,17,19B,20B,25,26 ---	1-10, 12-42, 44,48-51
2	X US 4 766 895 A (REYNOLDS ALVIN E) 30 August 1988 (1988-08-30) column 6, line 38 - line 54; figures 6,7 ---	1-4, 32-37, 41,42,44
2	A WO 98 25547 A (LEE JOSEPH Y) 18 June 1998 (1998-06-18) page 20, line 15 - line 25 ---	22,23
2	E WO 99 49813 A (MICROOPTIX LLC) 7 October 1999 (1999-10-07) abstract figure 10B ---	1,32
2	P,X WO 99 36013 A (MICROOPTIX LLC) 22 July 1999 (1999-07-22) figures 15B-F,17A -----	1,32,48

INTERNATIONAL SEARCH REPORT

International application No.

PCT/US 99/ 17762

Box I Observations where certain claims were found unsearchable (Continuation of item 1 of first sheet)

This International Search Report has not been established in respect of certain claims under Article 17(2)(a) for the following reasons:

1. Claims Nos.: 52-56
because they relate to subject matter not required to be searched by this Authority, namely:
Rule 39.1(iv) PCT
2. Claims Nos.:
because they relate to parts of the International Application that do not comply with the prescribed requirements to such an extent that no meaningful International Search can be carried out, specifically:
3. Claims Nos.:
because they are dependent claims and are not drafted in accordance with the second and third sentences of Rule 6.4(a).

Box II Observations where unity of invention is lacking (Continuation of item 2 of first sheet)

This International Searching Authority found multiple inventions in this international application, as follows:

1. As all required additional search fees were timely paid by the applicant, this International Search Report covers all searchable claims.
2. As all searchable claims could be searched without effort justifying an additional fee, this Authority did not invite payment of any additional fee.
3. As only some of the required additional search fees were timely paid by the applicant, this International Search Report covers only those claims for which fees were paid, specifically claims Nos.:
4. No required additional search fees were timely paid by the applicant. Consequently, this International Search Report is restricted to the invention first mentioned in the claims; it is covered by claims Nos.:

Remark on Protest

- The additional search fees were accompanied by the applicant's protest.
- No protest accompanied the payment of additional search fees.

INTERNATIONAL SEARCH REPORT

Information on patent family members

International Application No

PCT/US 99/17762

Patent document cited in search report	Publication date	Patent family member(s)	Publication date
US 5323788 A	28-06-1994	AT 185063 T	15-10-1999
		AU 683430 B	13-11-1997
		AU 5129893 A	12-04-1994
		BR 9307077 A	29-06-1999
		CN 1087254 A	01-06-1994
		DE 69326622 D	04-11-1999
		EP 0660692 A	05-07-1995
		IL 107036 A	27-12-1998
		JP 8504115 T	07-05-1996
		WO 9406381 A	31-03-1994
		US 5645582 A	08-07-1997
WO 9503755 A	09-02-1995	AU 6996398 A	16-07-1998
		AU 687859 B	05-03-1998
		AU 7515694 A	28-02-1995
		BR 9407215 A	17-09-1996
		CA 2168347 A	09-02-1995
		EP 0712301 A	22-05-1996
		IL 110532 A	06-12-1998
		JP 9503930 T	22-04-1997
		SG 52643 A	28-09-1998
		US 5824086 A	20-10-1998
		WO 9728759 A	14-08-1997
CA 2216205 A	14-08-1997		
EP 0822790 A	11-02-1998		
JP 11503657 T	30-03-1999		
US 4766895 A	30-08-1988	US 4452235 A	05-06-1984
		US 5505722 A	09-04-1996
		US 5188125 A	23-02-1993
		US 5312424 A	17-05-1994
		CA 1190444 A	16-07-1985
		EP 0083494 A	13-07-1983
		HK 23688 A	08-04-1988
		JP 2555485 B	20-11-1996
		JP 6209964 A	02-08-1994
		JP 1698172 C	28-09-1992
		JP 3061455 B	19-09-1991
		JP 58141148 A	22-08-1983
		SG 47487 G	20-05-1988
		US 4961744 A	09-10-1990
		US 4671276 A	09-06-1987
		WO 9825547 A	18-06-1998
US 5855604 A	05-01-1999		
US 5876439 A	02-03-1999		
AU 5596698 A	03-07-1998		
EP 0964660 A	22-12-1999		
WO 9949813 A	07-10-1999	NONE	
WO 9936013 A	22-07-1999	AU 2227399 A	02-08-1999