

*A. K. Rider,*

*Fan Blower.*

*No. 101,510.*

*Patented Apr. 5, 1870.*

*Fig. 1.*

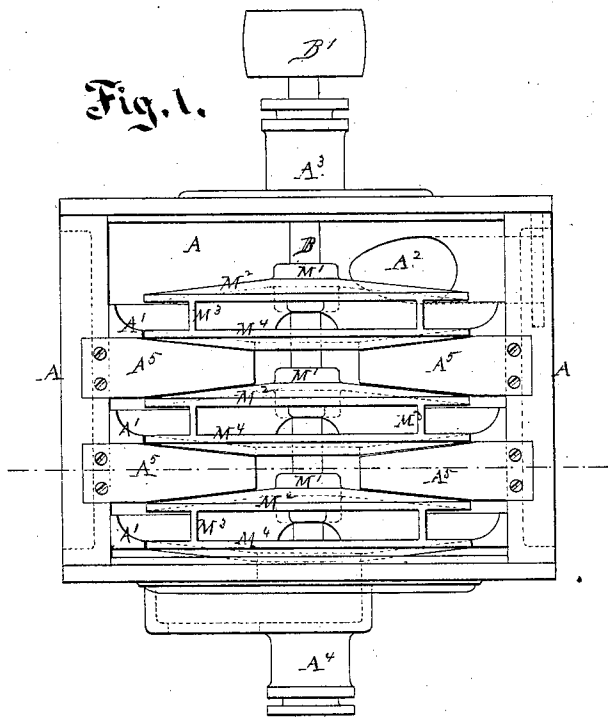

*Fig. 2.*

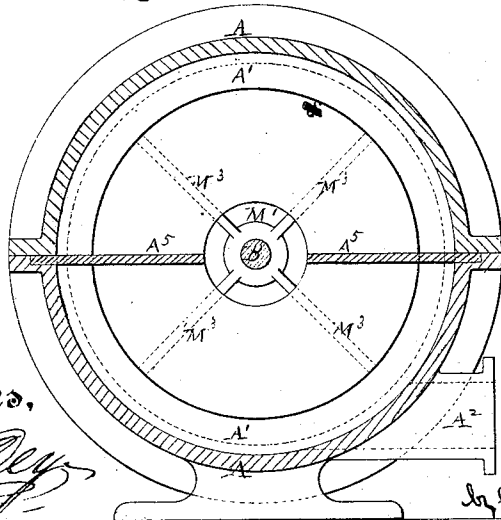

Witnesses,

*[Signature]*  
*D. Doermann.*

Inventor,

*A. K. Rider*  
by his atty  
*[Signature]*

# United States Patent Office.

ALEXANDER K. RIDER, OF NEW YORK, N. Y., ASSIGNOR TO HIMSELF, C. H. DE LAMATER, AND GEORGE H. REYNOLDS, OF SAME PLACE.

Letters Patent No. 101,510, dated April 5, 1870.

## IMPROVEMENT IN COMPOUND BLOWERS.

The Schedule referred to in these Letters Patent and making part of the same.

To all whom it may concern :

Be it known that I, ALEXANDER K. RIDER, of the city and county of New York, and State of New York, have invented a certain new and improved construction of Blower; and I do hereby declare that the following is a full and exact description thereof.

My invention relates to that class of fan-blowers known as compound, in which the air from one fan is received into another, and the slight pressure induced by the action of the first fan is increased successively by the series of fans through which the air passes in succession.

My blower, like most or all others, can be used as a pump, if desired, and it may be so understood throughout the entire specification that, by substituting water or oil or other fluid for air, with or without modifying the proportions and increasing the power, the machine, although everywhere called a blower, may be equally well used as a centrifugal pump.

I will first describe what I consider the best means of carrying out my invention.

Figure 1 is

Similar letters of reference indicate like parts in all the figures.

A is a fixed casing, open at both ends.

A<sup>1</sup> A<sup>1</sup> are internal flanges, extending around on the interior, which are perpendicular or plane on one face, and hollow, as represented, on the other face.

A<sup>2</sup> is a nozzle, adapted for ready connection to a pipe or duct to carry away the air, and lead it to the furnace or other point where it is desired to blow. This nozzle is placed tangential to the case A.

A shaft, B, is mounted in fixed bearings, A<sup>3</sup> A<sup>4</sup>, in the axial line or center of the case A.

It is provided with a small pulley, B<sup>1</sup>, adapted to receive a rapid rotary motion from a belt (not represented) leading from a steam-engine or other suitable power.

Instead of simply winged hubs, I mount comparatively close wheels on the shaft B.

I designate each wheel collectively by the letter M, and will designate the parts thereof by M<sup>1</sup> M<sup>2</sup>, &c.

M<sup>1</sup> is the hub, keyed or otherwise fixed firmly on the shaft B.

M<sup>2</sup> is a continuous plate, fixed on the hub, and extending outward therefrom in all directions, as represented.

M<sup>3</sup> M<sup>3</sup> are wings; and

M<sup>4</sup> is another continuous plate, nearly parallel to the plate M<sup>2</sup>, but nearer thereto at the periphery than near the center. The plate M<sup>4</sup> does not connect directly to the hub. It is cast or otherwise fixed firmly to the wings M<sup>3</sup>, leaving a liberal opening for air to flow through the space between the inner edge of the plate M<sup>4</sup> and the hub M<sup>1</sup>.

The entire wheel M may be made of cast-iron, and turned and polished on its faces, so as to reduce the friction against the air. It is much easier to thus make smooth the exterior of a symmetrical wheel than to correspondingly smooth the interior of any casing.

The wings M<sup>3</sup> are analogous to the blades of ordinary fans. They may stand exactly radial, or they may be slanted or curved backward, or in any other direction, according to the judgment or whim of the constructor. In either case they are tightly fixed to the plates or sides M<sup>2</sup> M<sup>4</sup>, and should, by preference, present smooth surfaces, and extend continuously from near the shaft B to the extreme periphery of the plates M<sup>2</sup> M<sup>4</sup>.

All the interior surfaces of my blowing-wheels M should, by preference, be smooth, but this is not very material.

The motion of the air across these surfaces is slow. The particles of air move outward in lines directly radial relatively to the wheel.

It is a matter of indifference if the interior of the wheels are grooved or otherwise roughened, even to a great extent, provided the roughnesses are in radial lines, corresponding to the slow motion of the air.

The blowing-wheels M are fitted close to the inner edges of the corresponding flanges A<sup>1</sup>, which are turned and polished to adapt them to be mounted in close proximity without actual contact.

My wheels as constructed have great stiffness, and I find it practicable to run them very close to the flanges without inducing actual contact.

I provide two or other desired number of fixed wings, A<sup>5</sup>, extending inward from the interior of the casing A to about the inner edge of the plates M<sup>4</sup> of the several wheels M. These wings are finished at their edges, and mounted, so as to approach very near the polished faces of the wheels M.

The action of my improved blower will now be readily understood. On setting the shaft B and its connections in rapid rotation, the outer blowing-wheel receives air at the center, gives it a rapid rotation by its wings M<sup>3</sup>, and ejects it against the inclined or hollowed face of an internal flange, A<sup>1</sup>, which, deflecting it against the wing A<sup>5</sup>, causes its rotation to be instantly arrested, and allows it to flow quietly inward to the center of the next wheel M, where it is again seized by the wings M<sup>3</sup> of the next blowing-wheel.

This operation may be repeated as many times as may be preferred, and at each operation the pressure of the air is increased without subjecting the air to the friction which it experiences in being whirled with corresponding rapidity in the ordinary fixed and comparatively rough casings.

After the air has been discharged from the periph-

ery of either blowing-wheel, it is immaterial what amount of roughness and frictional resistance it encounters on the hollow or deflecting side of the flange A<sup>1</sup>, on the interior of the casing A. At that stage of its progress it becomes necessary to arrest its rapid rotary motion, and it is not material to the consumption of power whether this is all arrested suddenly by contact with the wings A<sup>5</sup>, or whether a portion is arrested previously by the friction against the parts A<sup>1</sup> and A. But any friction which it would encounter in traversing outward along the wing or fan M<sup>3</sup>, would be an unnecessary resistance to the action, which it is one important object of my invention to reduce.

While it is true that the friction of the outer surface of each wheel against the air, as it quietly returns between the wheels, is a resisting friction; and tends, so far as it goes, to balance the gain due to the removal of the friction while under the action of the fan, this resistance can be made much less by reason of the facilities which my invention affords for smoothing the frictional surfaces.

The stiff construction of my wheels also allows a much closer fit of the joints, and consequently a re-

duction of the leakage backward, without involving risk of frictional contact.

I propose to balance the end pressure on my shaft B by mounting two complete sets of wheels M M, &c., in positions reverse to each other on each side of the discharging-nozzle A<sup>2</sup>, as represented in fig. This tends to still further increase the efficiency of my compound blower, by receiving air at each end and discharging it under as high a pressure as may be desired through the same central nozzle A<sup>2</sup>.

By increasing the length of the casing A, the number of wheels M, and the number of the flanges A<sup>1</sup> and wings A<sup>5</sup>, I can increase the pressure of the air indefinitely.

I claim the compound blower herein described, having smooth-surfaced blowing-wheels M, and fixed wings A<sup>5</sup>, arranged either in a double or single series, in the manner and for the purposes herein set forth.

In testimony whereof I have hereunto set my name in presence of two subscribing witnesses.

Witnesses:

A. K. RIDER.

A. HOERMANN.

H. E. PRICE.