

N. SLEEMAN.  
Gas-Regulator.

No. 219,989.

Patented Sept. 23, 1879.

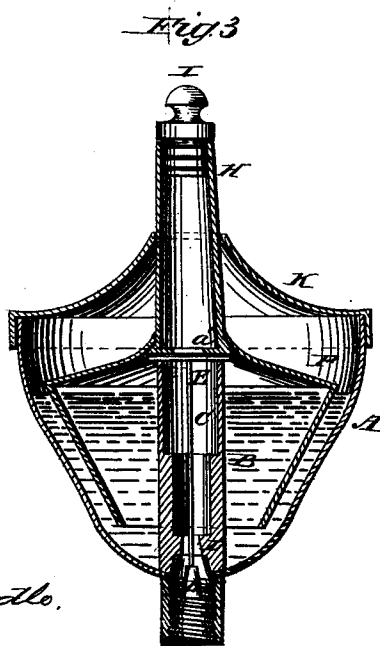
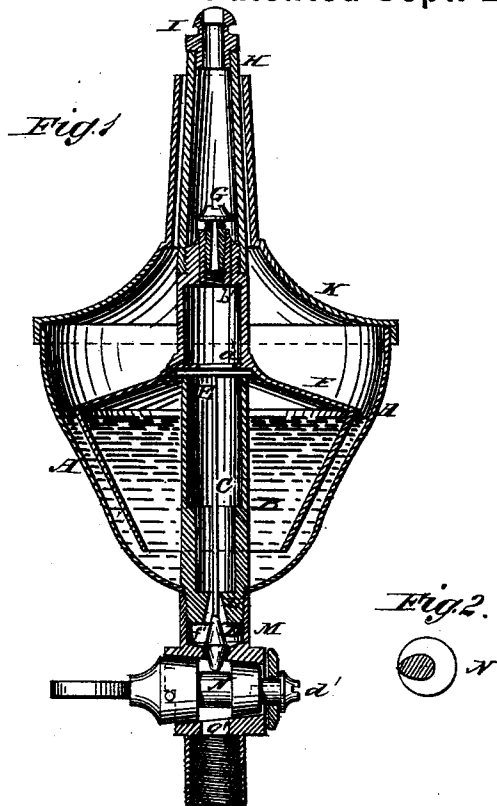

WITNESSES:  
*Francis McArdle.*  
*C. Sedgwick*

INVENTOR:  
*N. Sleeman*  
BY *Munn & Co.*  
ATTORNEYS.

# UNITED STATES PATENT OFFICE.

NATHANIEL SLEEMAN, OF BIRMINGHAM, ASSIGNOR, BY MESNE ASSIGNMENT, TO NATIONAL GAS SAVING COMPANY, OF ANSONIA, CONN.

## IMPROVEMENT IN GAS-REGULATORS.

Specification forming part of Letters Patent No. 219,989, dated September 23, 1879; application filed April 29, 1879.

*To all whom it may concern:*

Be it known that I, NATHANIEL SLEEMAN, of Birmingham, in the county of New Haven and State of Connecticut, have invented a new and useful Governor Gas-Burner, of which the following is a specification.

Figures 1 and 3 represent vertical sections, respectively, of a street and house gas-regulating burner. Fig. 2 is a cross-section of cam N.

Similar letters of reference indicate corresponding parts.

The object of this invention is to furnish a gas-burner provided with a governor for regulating and cutting off the flow of gas.

This device is especially applicable to street lights or lamps, for by its use all the lights of a city may be almost simultaneously extinguished by simply removing for a few minutes the pressure of the gas at the gas-works.

A is a casing, preferably made cup-shaped, with a tube, B, passing up through its center and projecting slightly below its bottom, where the diameter of the bore of the tube is very considerably contracted by a valve-seat tube, L, the lower end of which offers a seat for the valve. Extending up through this valve-seat tube is a valve-rod, C, carrying on its lower end, and below the valve-seat tube, the valve D, which consists of a long round plug of metal swelling at the center and tapering to each end. To the upper end of this valve-rod is fastened the cross-bar E, that extends across the upward central tubular extension *a'* of the float F, and is soldered or otherwise fastened to the top of the float. The top of the float resembles a circular disk slightly elevated at the center, where it surrounds the central tubular extension, and slopes downward to its edge, to which is soldered or otherwise fastened the broad conical ring that projects downward and forms the sides of the float. In the top of the tubular extension *a'* is inserted a bushing, *b'*, projecting upward, into which the split screw or check G is set, which can be adjusted to regulate the flow of gas to the burner. The tube or burner H, having in its smaller end the tip I, is screwed on the bushing *b'*, so as to inclose

the split screw or check G. The cap or cover K of the device, with its central and upward projecting tube, is then set in position, as shown in the drawings. Screwed onto the valve-seat tube L is the connecting-pipe M, having an enlarged transverse chamber, through which the cam N is inserted, and held by nut *d'*. The upper wall of this chamber is pierced with a hole, *f'*, for the upward flow of gas, and affords a seat for the valve as it is moved downward, while the lower wall of the chamber is provided with a hole, *g'*, for the admission of gas from the street-pipes. The float is suspended in glycerine contained in the case or shell A. The course of gas entering the connecting-pipe is through the hole *g'* into the transverse chamber, and thence through the hole *f'*, valve-seat tube L, tube B, bushing *b'*, split screw G, and burner H to the tip I.

Should the pressure from the main increase above the desired point, the float will be lifted and draw up with it the valve D into the upper valve-seat, so as to limit the flow of the gas and relieve the excessive pressure within the device. On cessation of the pressure the float will fall again, and the gas-port through the upper valve-seat be correspondingly opened. Should the pressure at any time be insufficient to keep the float raised at all, the valve will fall and close the port in the lower valve-seat, as shown in Fig. 1, unless the cam N be turned so that its edge shall come in contact with the valve and hold it up. Thus it will be seen that the valve can be adjusted and the ports kept open for the passage of gas to the burners when the gas-pressure is reduced to a minimum.

The flow of gas to the burner may also be regulated by turning the split screw or check G up or down, so as to increase or diminish its side openings.

In Fig. 3 the governor gas-burner is shown without the cam and its necessary attachments. The valve also is of different shape from that shown in Fig. 1, because of the absence of the cam and its chamber; but in other respects the devices and their operations are identical. This burner shown in Fig. 3, being designed more especially for use in houses containing

gas-meters, does not require all the governing devices that it does when applied to street-lamps.

I am aware that there are many devices for regulating the flow of gas through pipes that are designed to control the supply and pressure of two or more burners at one and the same time; but I am not aware that a burner attached directly to an efficient governor or regulator has ever before been devised.

It will be observed that both economy in space and simplicity of parts are gained by arranging all the gas-ports and passages perpendicularly one above the other.

Having thus described my invention, I claim as new and desire to secure by Letters Patent—

1. The within-described governor gas-burner, consisting of the case A, tube B, valve-rod C, valve D, cross-bar E, float F, check G, burner H, tip I, cover K, tube L, provided with a valve-seat, chambered connecting-pipe M, provided with valve-seat and gas-ingress port *g'*, and cam N, substantially as and for the purpose described.

2. The within-described governor gas-burner, consisting of the case A, tube B, valve-rod C, valve D, cross-bar E, float F, burner H, tip I, cover K, and valve-seat tube L, provided with a valve-seat, substantially as and for the purpose described.

NATHANIEL SLEEMAN.

Witnesses:

DAVID TORRANCE,  
WM. B. WOOSTEE.